

ILLUSTRATED PARTS LIST

MODEL NUMBER ST 268EP

PRODUCT NUMBER 961 91 00-38

MFG. ID. NUMBER 96191003803

REPAIR PARTS

AUGER HOUSING / IMPELLER ASSEMBLY

SNOW THROWER - MODEL NO. **ST 268EP** (96191003803), PRODUCT NO. 961 91 00-38

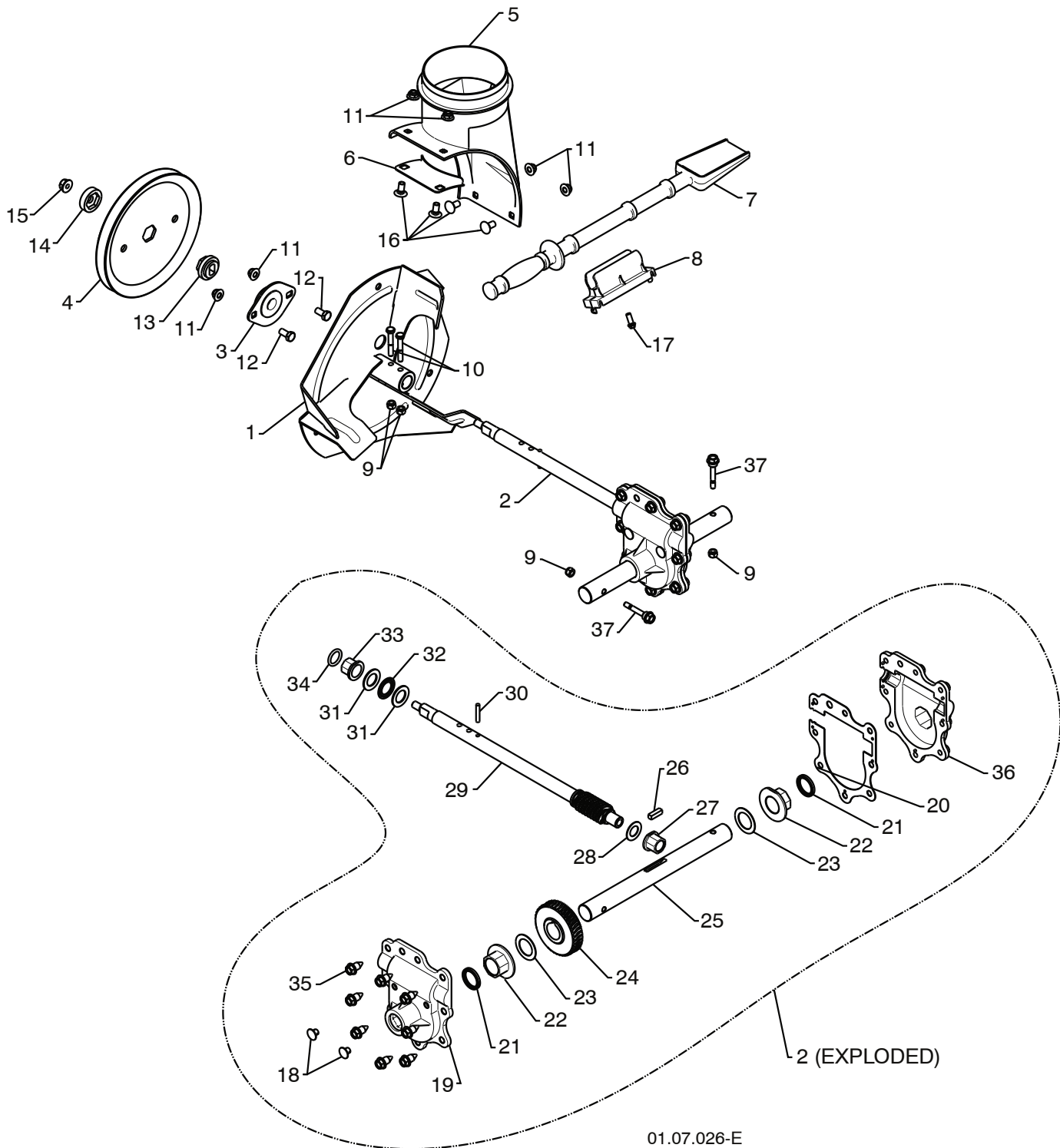

NOTE: All component dimensions given in U.S. inches. 1 inch = 25.4 mm
IMPORTANT: Use only Original Equipment Manufacturer (O.E.M.) replacement parts.
Failure to do so could be hazardous, damage your snow thrower and void your warranty.

REPAIR PARTS

AUGER HOUSING / IMPELLER ASSEMBLY

SNOW THROWER - MODEL NO. **ST 268EP** (96191003803), PRODUCT NO. 961 91 00-38

| KEY NO. | PART NO. | DESCRIPTION |
|---------|--------------|----------------------|
| 1 | 532 18 41-05 | IMPELLER |
| 2 | 532 42 71-48 | GEARBOX ASSEMBLY |
| 3 | 532 18 89-09 | BEARING |
| 4 | 532 42 71-46 | IMPELLER PULLEY |
| 5 | 532 44 24-38 | DISCHARGE BASE |
| 6 | 532 18 40-95 | CORNER BRACKET |
| 7 | 532 19 21-99 | CLEAN OUT TOOL |
| 8 | 532 40 54-00 | TOOL CLIP |
| 9 | 873 80 04-00 | NUT 1/4-20 |
| 10 | 874 78 04-26 | SCREW 1/4-20 X .625 |
| 11 | 532 42 79-42 | NUT 5/16-18 |
| 12 | 532 16 31-83 | SCREW 5/16-18 X .625 |
| 13 | 532 42 71-45 | IMPELLER HUB |
| 14 | 532 42 71-54 | IMPELLER SLEEVE |
| 15 | 873 90 06-00 | NUT 3/8-16 |
| 16 | 532 18 03-55 | CARRIAGE BOLT |
| 17 | 532 19 41-89 | SCREW 13-16 X .625 |
| 18 | 532 40 77-60 | PLUG |
| 19 | 532 42 73-02 | GEARBOX COVER RH |
| 20 | 532 42 73-45 | GASKET |
| 21 | 532 40 77-70 | SEAL |
| 22 | 532 40 77-62 | BEARING |
| 23 | 532 17 46-97 | THRUST WASHER 1.00 |
| 24 | 532 40 77-63 | WORM GEAR |
| 25 | 532 40 77-64 | AUGER SHAFT |
| 26 | 532 18 92-82 | SQUARE KEY |
| 27 | 532 40 77-58 | BEARING |
| 28 | 532 17 46-83 | THRUST WASHER |
| 29 | 532 42 71-47 | IMPELLER SHAFT |
| 30 | 532 18 42-05 | ROLL PIN |
| 31 | 532 17 46-81 | THRUST WASHER |
| 32 | 532 17 46-84 | THRUST BEARING |
| 33 | 532 40 77-69 | BEARING |
| 34 | 532 40 77-68 | O-RING |
| 35 | 532 40 77-67 | SCREW 5/16-18 X .750 |
| 36 | 532 42 73-17 | GEARBOX COVER LH |
| 37 | 532 19 20-90 | SHEAR BOLT |

NOTE: All component dimensions given in U.S. inches. 1 inch = 25.4 mm

IMPORTANT: Use only Original Equipment Manufacturer (O.E.M.) replacement parts. Failure to do so could be hazardous, damage your snow thrower and void your warranty.

REPAIR PARTS

AUGER HOUSING / IMPELLER ASSEMBLY

SNOW THROWER - MODEL NO. **ST 268EP** (96191003803), PRODUCT NO. 961 91 00-38

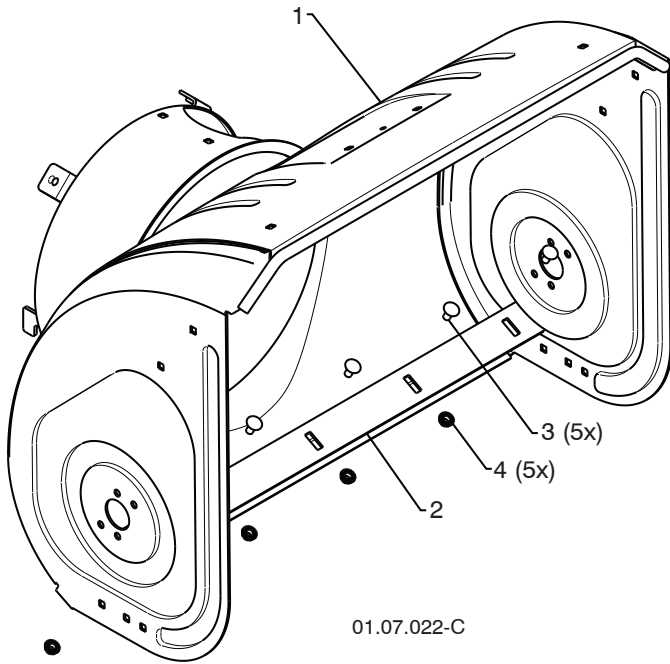

01.07.022-C

| KEY NO. | PART NO. | DESCRIPTION |
|---------|--------------|------------------------------|
| 1 | 532 42 95-87 | AUGER HOUSING |
| 2 | 532 40 77-27 | SCRAPER BAR |
| 3 | 872 27 05-05 | CARRIAGE BOLT 5/16-18 X .625 |
| 4 | 532 15 53-77 | NUT 5/16-18 |

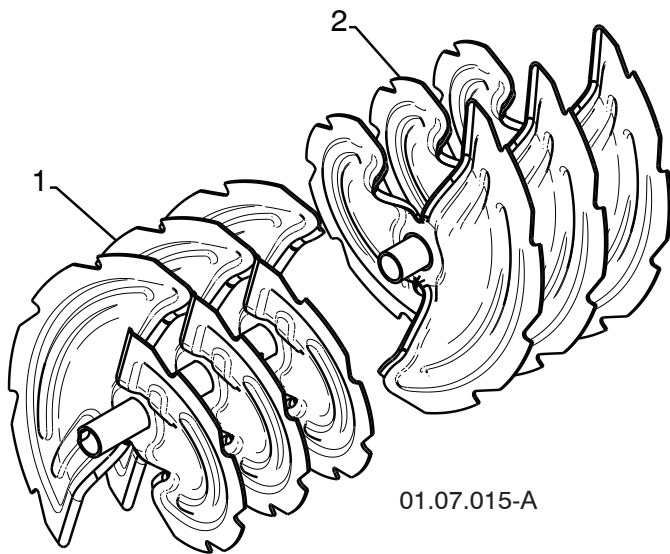

01.07.015-A

| KEY NO. | PART NO. | DESCRIPTION |
|---------|--------------|----------------------|
| 1 | 532 42 69-57 | AUGER ASSEMBLY 27 LH |
| 2 | 532 42 69-58 | AUGER ASSEMBLY 27 RH |

NOTE: All component dimensions given in U.S. inches. 1 inch = 25.4 mm
IMPORTANT: Use only Original Equipment Manufacturer (O.E.M.) replacement parts.
Failure to do so could be hazardous, damage your snow thrower and void your warranty.

REPAIR PARTS

AUGER HOUSING / IMPELLER ASSEMBLY

SNOW THROWER - MODEL NO. **ST 268EP** (96191003803), PRODUCT NO. 961 91 00-38

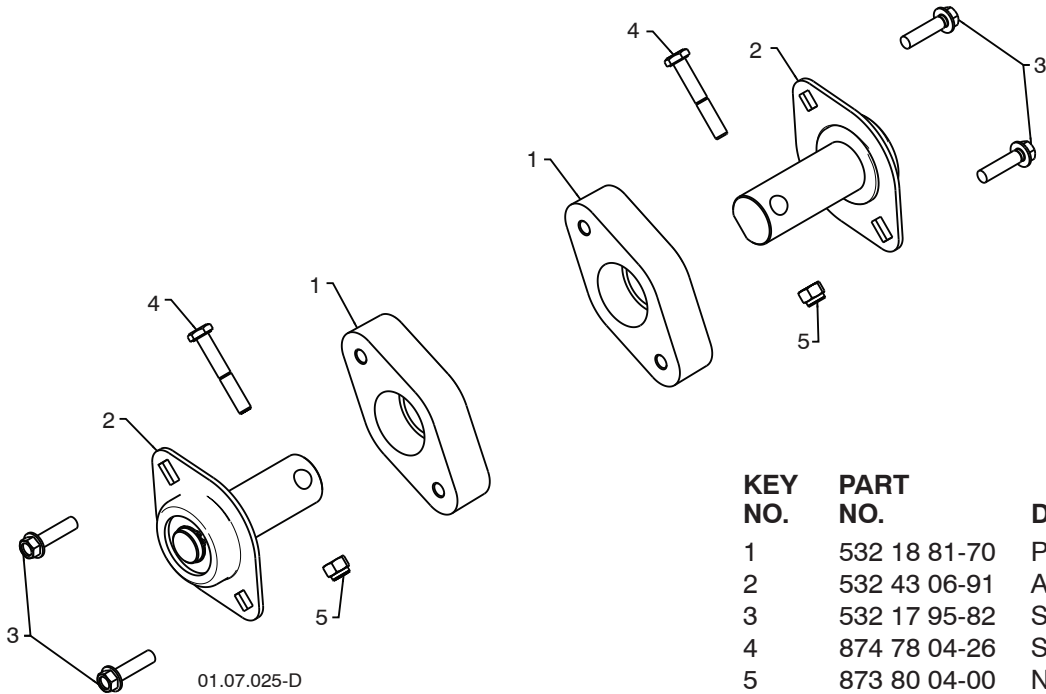

| KEY NO. | PART NO. | DESCRIPTION |
|---------|--------------|----------------------|
| 1 | 532 18 81-70 | PLASTIC RETAINER |
| 2 | 532 43 06-91 | AUGER BALL BEARING |
| 3 | 532 17 95-82 | SCREW 5/16-18 x 1.00 |
| 4 | 874 78 04-26 | SCREW 1/4-20 x .625 |
| 5 | 873 80 04-00 | NUT 1/4-20 |

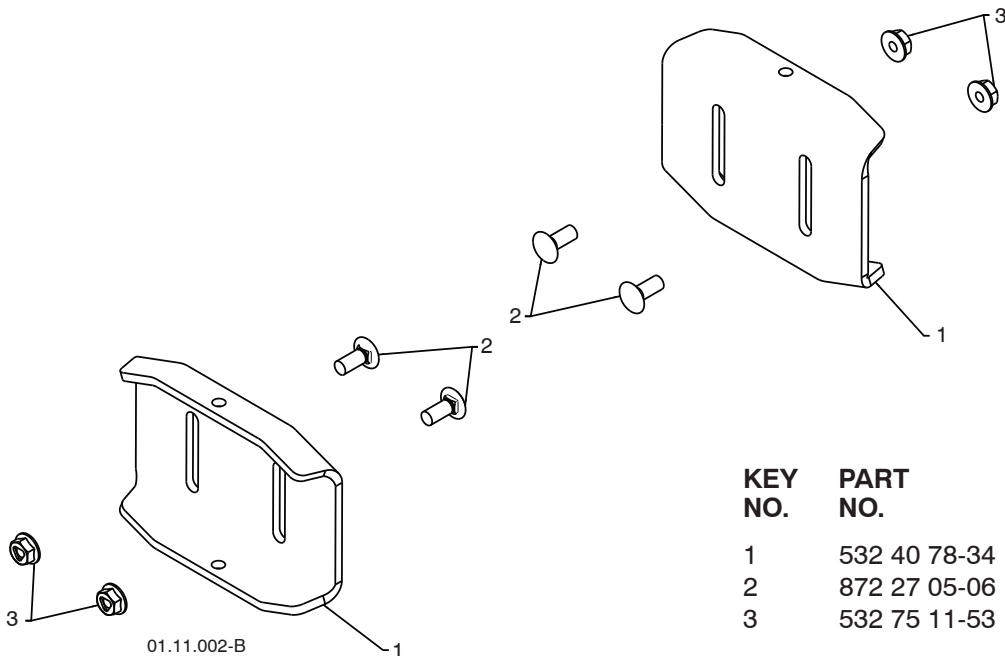

| KEY NO. | PART NO. | DESCRIPTION |
|---------|--------------|------------------------------|
| 1 | 532 40 78-34 | SKID PLATE |
| 2 | 872 27 05-06 | CARRIAGE BOLT 5/16-18 X .750 |
| 3 | 532 75 11-53 | NUT 5/16-18 |

NOTE: All component dimensions given in U.S. inches. 1 inch = 25.4 mm
IMPORTANT: Use only Original Equipment Manufacturer (O.E.M.) replacement parts.
 Failure to do so could be hazardous, damage your snow thrower and void your warranty.

REPAIR PARTS

AUGER HOUSING / IMPELLER ASSEMBLY

SNOW THROWER - MODEL NO. **ST 268EP** (96191003803), PRODUCT NO. 961 91 00-38

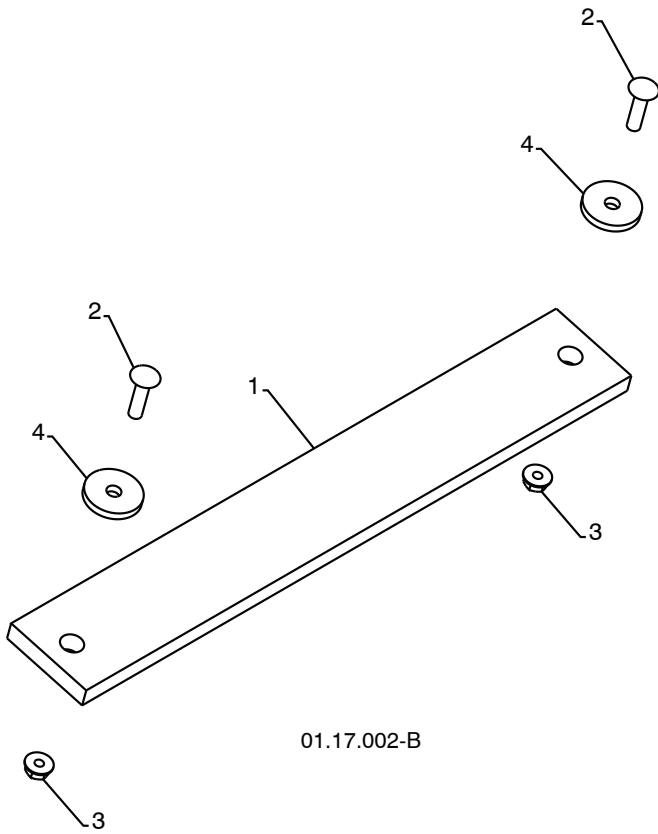

| KEY NO. | PART NO. | DESCRIPTION |
|---------|--------------|------------------------------|
| 1 | 532 18 25-15 | WEIGHT BAR |
| 2 | 872 11 05-10 | CARRIAGE BOLT 5/16-18 X 1.25 |
| 3 | 532 75 11-53 | NUT 5/16-18 |
| 4 | 819 11 22-06 | WASHER |

01.17.002-B

NOTE: All component dimensions given in U.S. inches. 1 inch = 25.4 mm
IMPORTANT: Use only Original Equipment Manufacturer (O.E.M.) replacement parts.
Failure to do so could be hazardous, damage your snow thrower and void your warranty.

REPAIR PARTS

CONTROL PANEL / DISCHARGE CHUTE

SNOW THROWER - MODEL NO. **ST 268EP** (96191003803), PRODUCT NO. 961 91 00-38

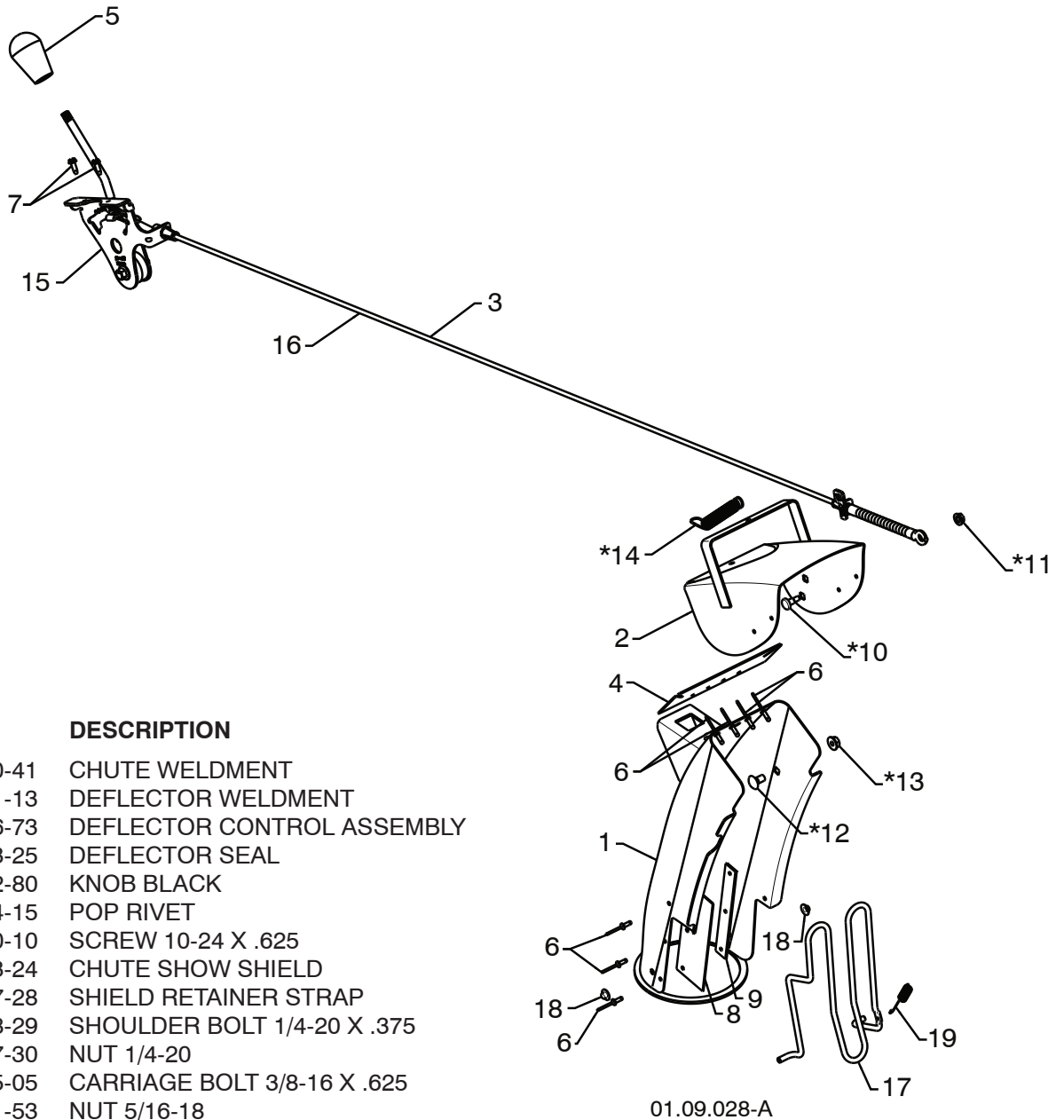

| KEY NO. | PART NO. | DESCRIPTION |
|---------|--------------|--------------------------------------|
| 1 | 532 44 40-41 | CHUTE WELDMENT |
| 2 | 532 18 41-13 | DEFLECTOR WELDMENT |
| 3 | 532 42 06-73 | DEFLECTOR CONTROL ASSEMBLY |
| 4 | 532 42 03-25 | DEFLECTOR SEAL |
| 5 | 532 41 42-80 | KNOB BLACK |
| 6 | 532 12 84-15 | POP RIVET |
| 7 | 817 50 10-10 | SCREW 10-24 X .625 |
| 8 | 532 43 03-24 | CHUTE SHOW SHIELD |
| 9 | 532 42 17-28 | SHIELD RETAINER STRAP |
| *10 | 532 17 98-29 | SHOULDER BOLT 1/4-20 X .375 |
| *11 | 532 19 17-30 | NUT 1/4-20 |
| *12 | 872 25 05-05 | CARRIAGE BOLT 3/8-16 X .625 |
| *13 | 532 75 11-53 | NUT 5/16-18 |
| *14 | 532 18 45-05 | DEFLECTOR SPRING |
| 15 | 532 42 06-79 | (SERVICE PART) DEFLECTOR CONTROL |
| 16 | 532 42 06-72 | (SERVICE PART) DEFLECTOR CABLE BLACK |
| 17 | 532 43 55-82 | CHUTE GUARD |
| 18 | 532 05 93-49 | PUSH NUT |
| 19 | 532 43 56-16 | SPRING |

NOTE:

1. ALL ITEMS INDICATED WITH AN * ARE PROVIDED IN THE BAG OF ITEMS SHIPPED LOOSE WITH PRODUCT.
2. ITEMS 15 AND 16 ARE SERVICE PART NUMBERS TO ALLOW PURCHASE OF INDIVIDUAL ITEMS IF NECESSARY.

NOTE: All component dimensions given in U.S. inches. 1 inch = 25.4 mm
IMPORTANT: Use only Original Equipment Manufacturer (O.E.M.) replacement parts.
 Failure to do so could be hazardous, damage your snow thrower and void your warranty.

REPAIR PARTS

CONTROL PANEL / DISCHARGE CHUTE

SNOW THROWER - MODEL NO. **ST 268EP** (96191003803), PRODUCT NO. 961 91 00-38

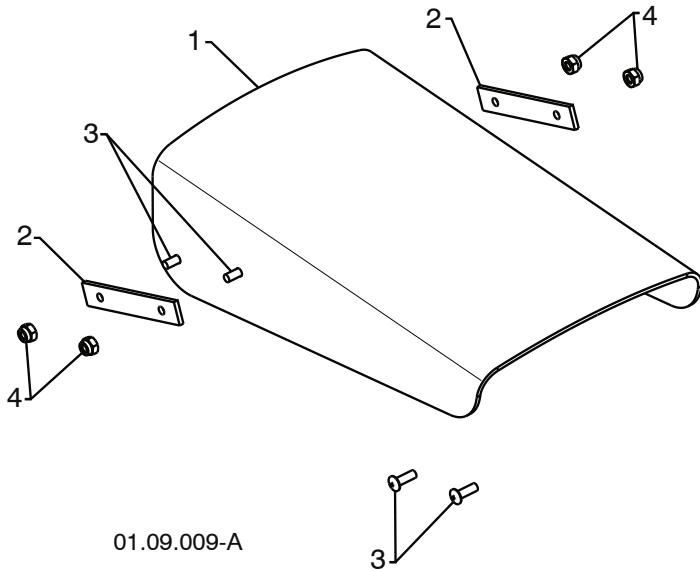

01.09.009-A

| KEY NO. | PART NO. | DESCRIPTION |
|---------|--------------|------------------|
| 1 | 532 42 11-38 | SHIELD DEFLECTOR |
| 2 | 532 42 32-47 | STRAP |
| 3 | 532 18 22-27 | SCREW 8-32 X .50 |
| 4 | 532 18 22-28 | NUT 8-32 |

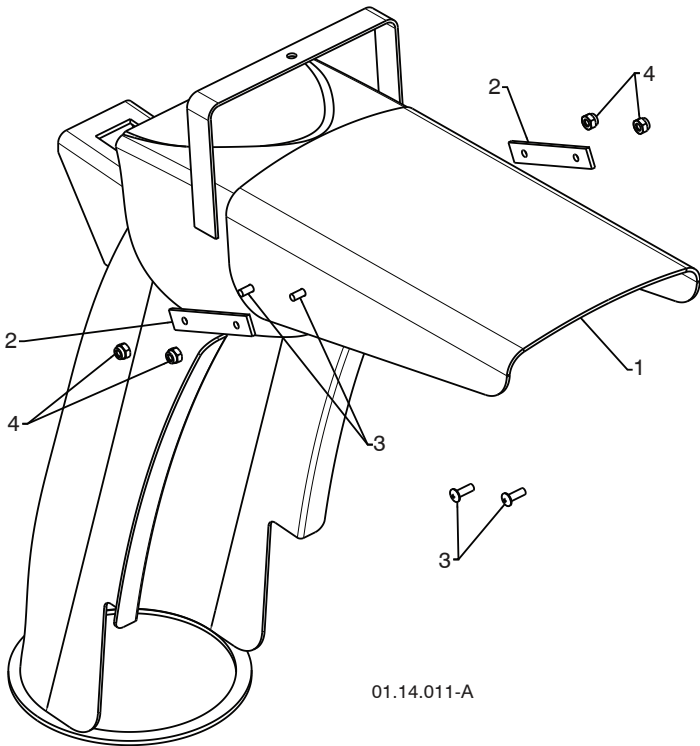

01.14.011-A

| KEY NO. | PART NO. | DESCRIPTION |
|---------|--------------|------------------|
| 1 | 532 42 11-38 | SHIELD DEFLECTOR |
| 2 | 532 42 32-47 | STRAP |
| 3 | 532 18 22-27 | SCREW 8-32 X .50 |
| 4 | 532 18 22-28 | NUT 8-32 |

NOTE: All component dimensions given in U.S. inches. 1 inch = 25.4 mm
IMPORTANT: Use only Original Equipment Manufacturer (O.E.M.) replacement parts.
Failure to do so could be hazardous, damage your snow thrower and void your warranty.

REPAIR PARTS

CONTROL PANEL / DISCHARGE CHUTE

SNOW THROWER - MODEL NO. **ST 268EP** (96191003803), PRODUCT NO. 961 91 00-38

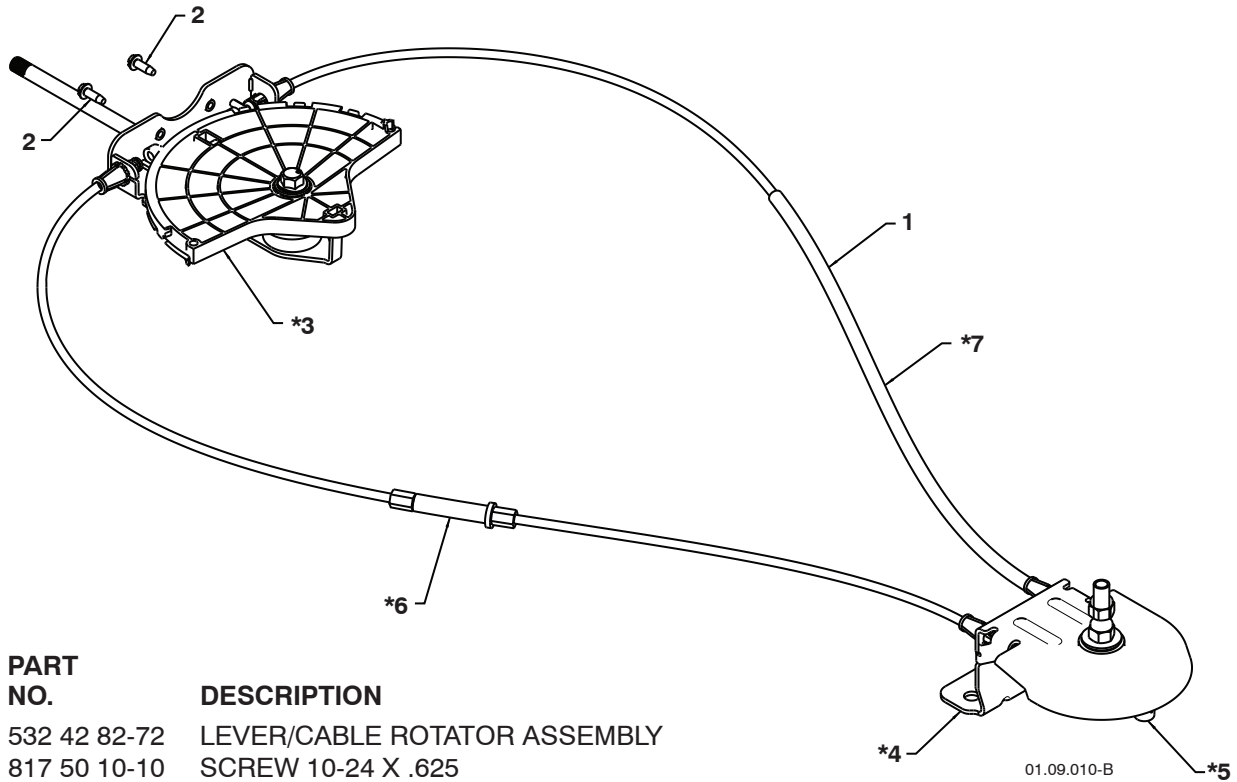

| KEY NO. | PART NO. | DESCRIPTION |
|---------|--------------|---------------------------------|
| 1 | 532 42 82-72 | LEVER/CABLE ROTATOR ASSEMBLY |
| 2 | 817 50 10-10 | SCREW 10-24 X .625 |
| *3 | 532 42 06-78 | ROTATOR HEAD |
| *4 | 532 40 59-32 | ROTATOR PIVOT BRACKET |
| *5 | 532 42 06-75 | PULLEY PIVOT |
| *6 | 532 42 82-73 | CABLE ASSEMBLY ADJUSTABLE GRAY |
| *7 | 532 42 83-10 | CABLE ASSEMBLY HEAT SHIELD GRAY |

NOTES:

1. ITEMS INDICATED WITH AN * ARE LISTED AS REFERENCE FOR SERVICE PARTS ONLY.

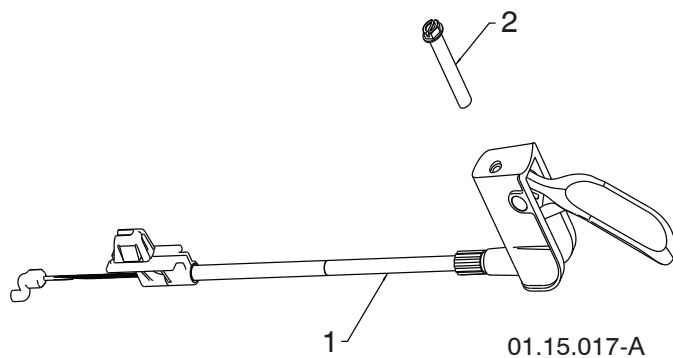

| KEY NO. | PART NO. | DESCRIPTION |
|---------|--------------|--------------------|
| 1 | 532 43 86-29 | STEER CABLE |
| 2 | 874 04 10-24 | SCREW 10-24 X 1.50 |

NOTE: All component dimensions given in U.S. inches. 1 inch = 25.4 mm
IMPORTANT: Use only Original Equipment Manufacturer (O.E.M.) replacement parts. Failure to do so could be hazardous, damage your snow thrower and void your warranty.

REPAIR PARTS

HANDLES

SNOW THROWER - MODEL NO. **ST 268EP** (96191003803), PRODUCT NO. 961 91 00-38

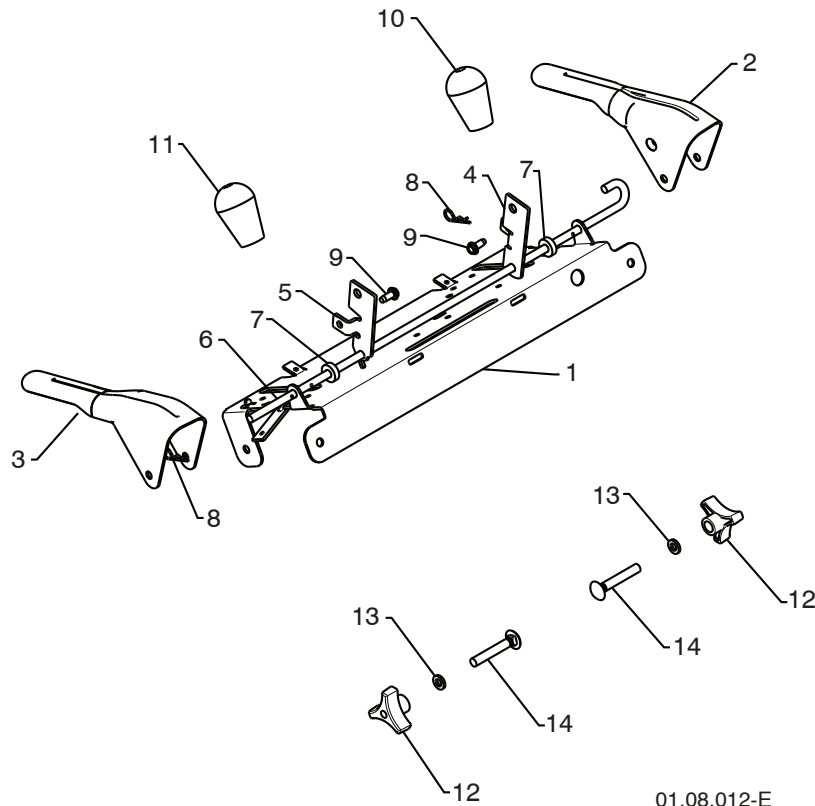

01.08.012-E

| KEY NO. | PART NO. | DESCRIPTION |
|---------|--------------|-----------------------------|
| 1 | 532 41 55-39 | CONTROL PANEL |
| 2 | 532 42 91-50 | CONTROL LEVER LH |
| 3 | 532 42 91-51 | CONTROL LEVER RH |
| 4 | 532 41 55-46 | TRACTION ROD ARM |
| 5 | 532 42 90-98 | IMPELLER ROD ARM |
| 6 | 532 41 26-77 | INTERLOCK ROD |
| 7 | 532 42 16-13 | SPACER |
| 8 | 532 16 96-75 | RETAINER |
| 9 | 817 06 04-10 | SCREW 1/4-20 X .62 |
| 10 | 532 41 42-80 | KNOB BLACK |
| 11 | 532 41 42-81 | KNOB RED |
| 12 | 532 17 88-99 | HANDLE KNOB |
| 13 | 819 13 13-16 | WASHER 3/8 |
| 14 | 872 12 06-18 | CARRIAGE BOLT 3/8-16 X 2.25 |

NOTE: All component dimensions given in U.S. inches. 1 inch = 25.4 mm
IMPORTANT: Use only Original Equipment Manufacturer (O.E.M.) replacement parts. Failure to do so could be hazardous, damage your snow thrower and void your warranty.

REPAIR PARTS

HANDLES

SNOW THROWER - MODEL NO. **ST 268EP** (96191003803), PRODUCT NO. 961 91 00-38

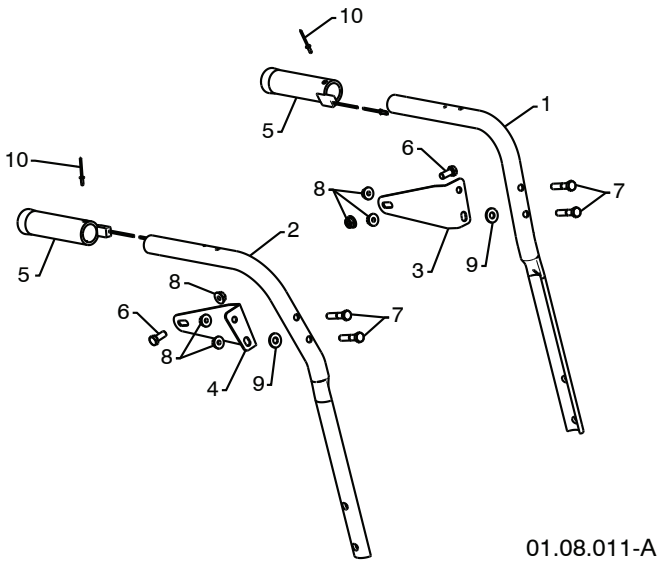

| KEY NO. | PART NO. | DESCRIPTION |
|---------|--------------|----------------------|
| 1 | 532 42 17-08 | PLOW HANDLE LH |
| 2 | 532 42 17-09 | PLOW HANDLE RH |
| 3 | 532 42 91-48 | PANEL BRACKET LH |
| 4 | 532 42 91-49 | PANEL BRACKET RH |
| 5 | 532 41 45-15 | HEATED HANDLE GRIP |
| 6 | 874 78 05-12 | SCREW 5/16-18 X .750 |
| 7 | 874 78 05-24 | SCREW 5/16-18 X 1.50 |
| 8 | 532 75 11-53 | NUT 5/16-18 |
| 9 | 532 15 54-15 | WASHER |
| 10 | 532 17 87-75 | POP RIVET 1/8 |

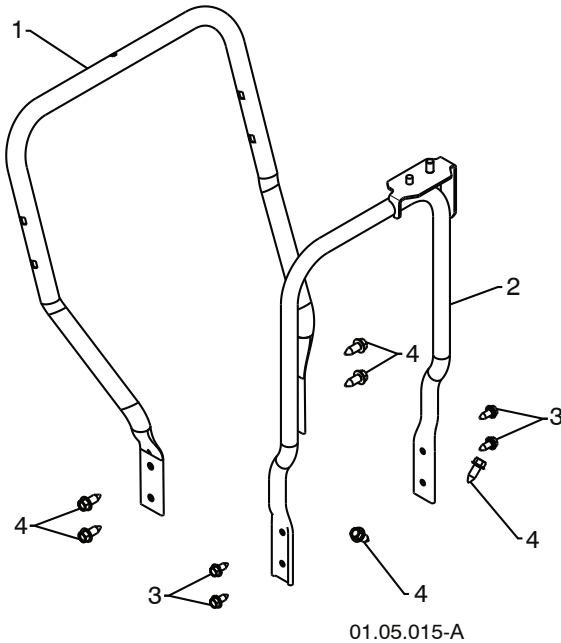

| KEY NO. | PART NO. | DESCRIPTION |
|---------|--------------|---------------------|
| 1 | 532 43 60-43 | LOWER HANDLE |
| 2 | 532 44 36-17 | PIVOT SUPPORT |
| 3 | 532 42 88-67 | BOLT 5/16-18 X .750 |
| 4 | 817 00 06-16 | SCREW 3/8-16 X 1.00 |

NOTE: All component dimensions given in U.S. inches. 1 inch = 25.4 mm
IMPORTANT: Use only Original Equipment Manufacturer (O.E.M.) replacement parts.
 Failure to do so could be hazardous, damage your snow thrower and void your warranty.

REPAIR PARTS

HANDLES

SNOW THROWER - MODEL NO. **ST 268EP** (96191003803), PRODUCT NO. 961 91 00-38

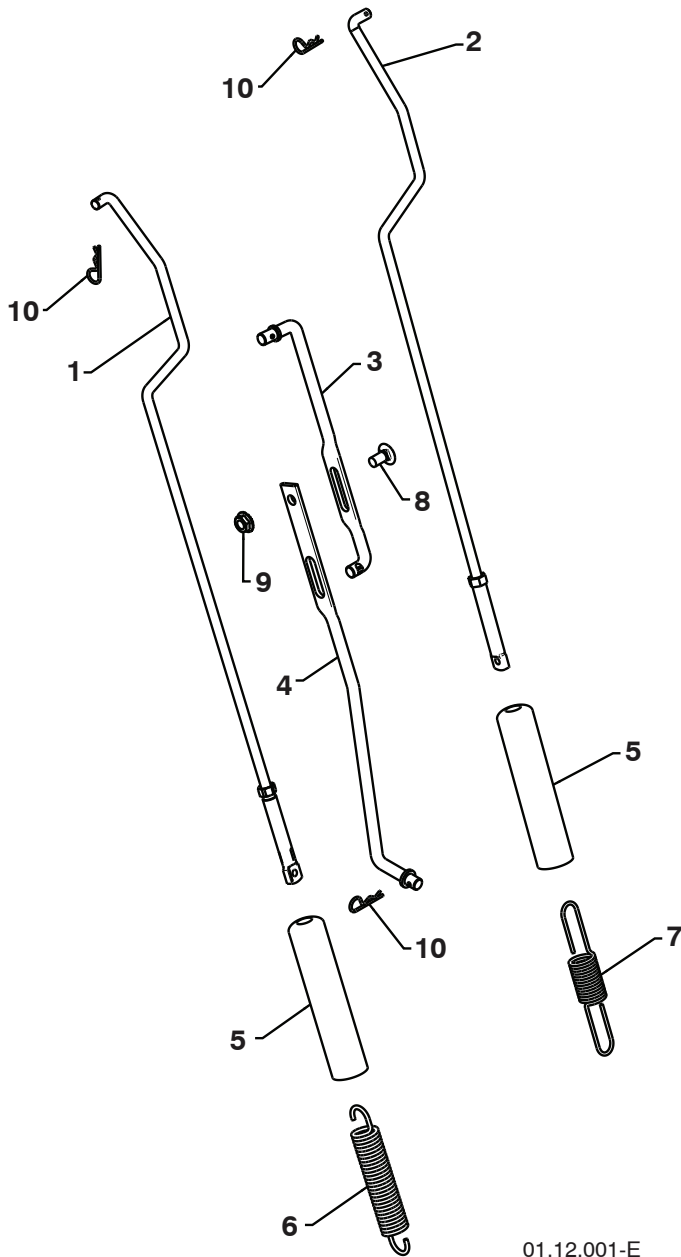

| KEY NO. | PART NO. | DESCRIPTION |
|---------|--------------|------------------------------|
| 1 | 532 18 04-80 | IMPELLER ROD ASSEMBLY |
| 2 | 532 40 57-40 | TRACTION ROD ASSEMBLY |
| 3 | 532 18 04-45 | SHIFTER ROD TOP |
| 4 | 532 18 77-16 | SHIFTER ROD BOTTOM |
| 5 | 532 18 04-47 | SPRING SLEEVE |
| 6 | 532 17 86-69 | IMPELLER SPRING |
| 7 | 532 18 09-26 | TRACTION SPRING |
| 8 | 872 27 05-05 | CARRIAGE BOLT 5/16-18 X .625 |
| 9 | 532 15 53-77 | NUT 5/16-18 |
| 10 | 532 16 96-75 | RETAINER |

01.12.001-E

NOTE: All component dimensions given in U.S. inches. 1 inch = 25.4 mm
IMPORTANT: Use only Original Equipment Manufacturer (O.E.M.) replacement parts. Failure to do so could be hazardous, damage your snow thrower and void your warranty.

REPAIR PARTS

HANDLES

SNOW THROWER - MODEL NO. **ST 268EP** (96191003803), PRODUCT NO. 961 91 00-38

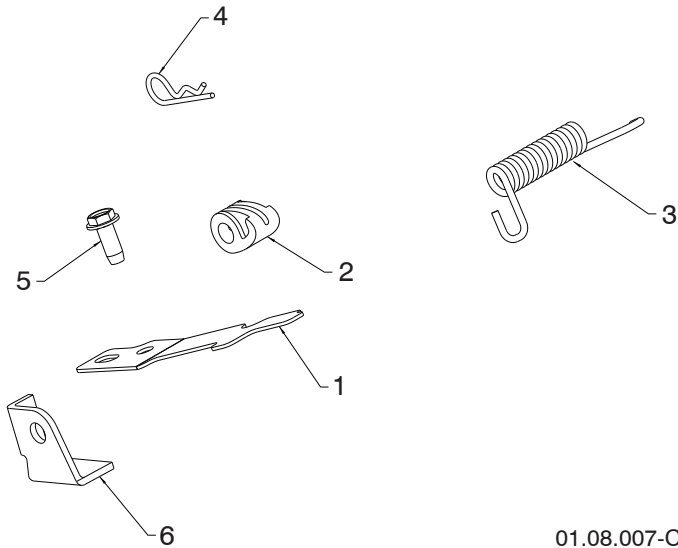

| KEY NO. | PART NO. | DESCRIPTION |
|---------|--------------|---------------------|
| 1 | 532 41 62-88 | INTERLOCK SPRING |
| 2 | 532 41 45-72 | INTERLOCK CAM |
| 3 | 532 44 32-15 | TORSION SPRING |
| 4 | 532 16 96-75 | RETAINER |
| 5 | 817 06 04-10 | SCREW 1/4-20 X .625 |
| 6 | 532 42 18-14 | INTERLOCK STOP |

01.08.007-C

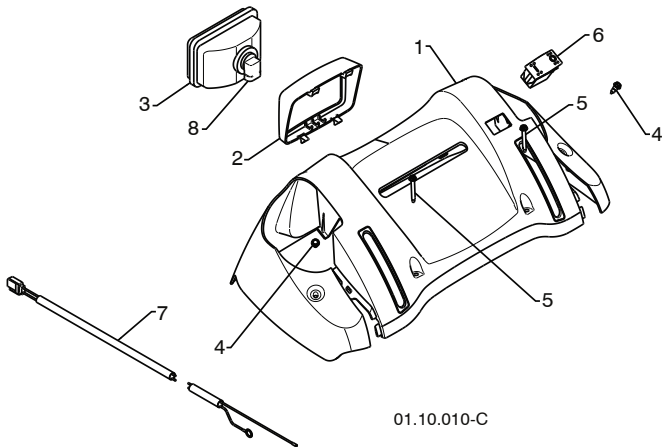

| KEY NO. | PART NO. | DESCRIPTION |
|---------|--------------|-------------------------|
| 1 | 532 42 13-51 | CONSOLE PANEL GRAY |
| 2 | 532 42 14-48 | HEADLIGHT BEZEL GRAY |
| 3 | 532 17 86-66 | HALOGEN HEADLIGHT |
| 4 | 532 18 44-71 | SHOULDERSCREW10-24X.625 |
| 5 | 532 17 52-62 | SCREW 10-24 X 1.25 |
| 6 | 532 41 77-60 | GRIP SWITCH |
| 7 | 532 40 56-99 | WIRE HARNESS |
| 8 | 532 40 16-20 | BULB |

01.10.010-C

NOTE: All component dimensions given in U.S. inches. 1 inch = 25.4 mm
IMPORTANT: Use only Original Equipment Manufacturer (O.E.M.) replacement parts.
 Failure to do so could be hazardous, damage your snow thrower and void your warranty.

REPAIR PARTS

DRIVE

SNOW THROWER - MODEL NO. **ST 268EP** (96191003803), PRODUCT NO. 961 91 00-38

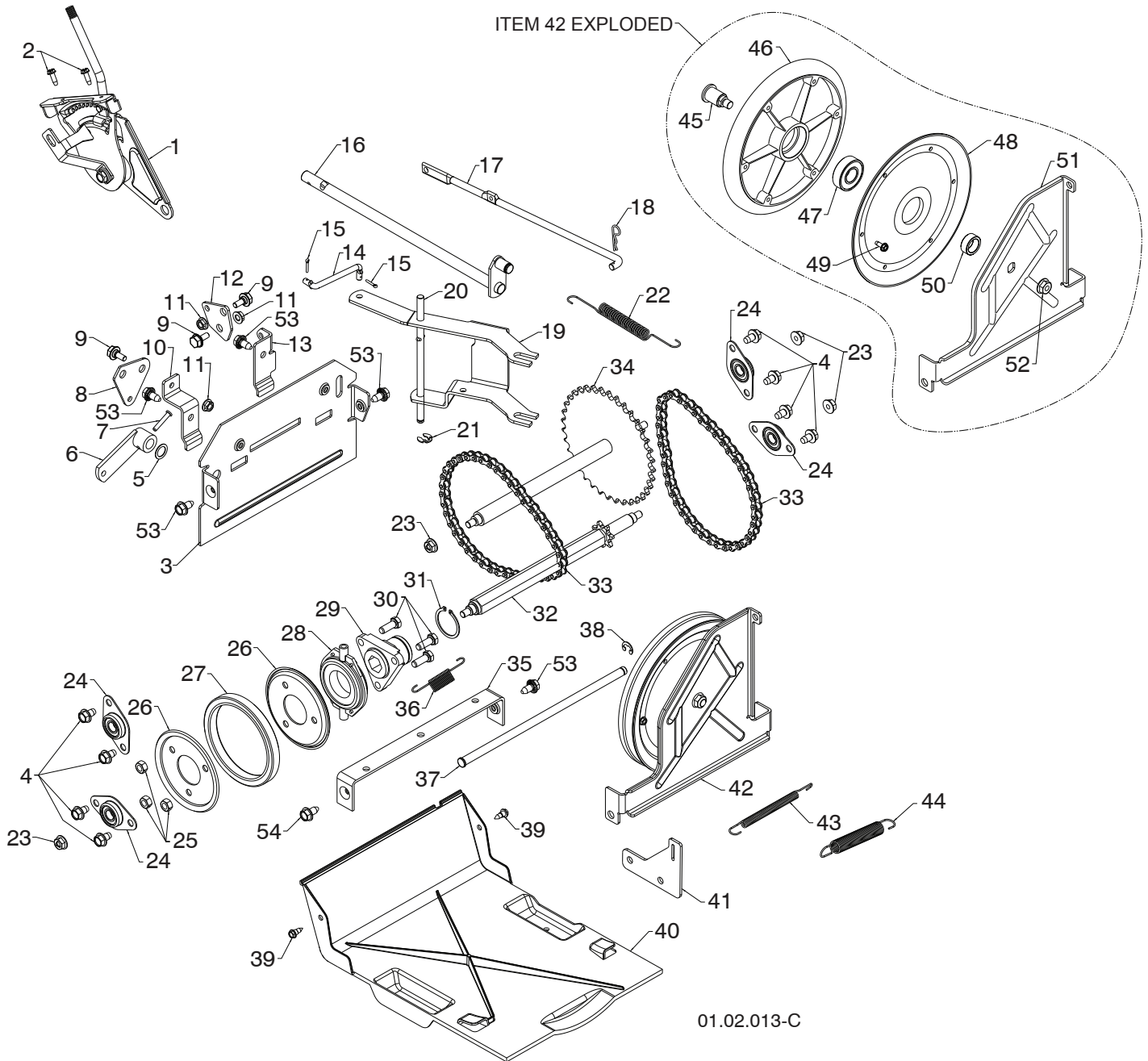

NOTE: All component dimensions given in U.S. inches. 1 inch = 25.4 mm
IMPORTANT: Use only Original Equipment Manufacturer (O.E.M.) replacement parts.
Failure to do so could be hazardous, damage your snow thrower and void your warranty.

REPAIR PARTS**DRIVE****SNOW THROWER - MODEL NO. ST 268EP (96191003803), PRODUCT NO. 961 91 00-38**

| KEY NO. | PART NO. | DESCRIPTION | KEY NO. | PART NO. | DESCRIPTION |
|---------|--------------|-------------------------|---------|--------------|----------------------|
| 1 | 532 19 88-75 | SPEED SELECTOR ASSEMBLY | 28 | 532 17 53-44 | BEARING |
| 2 | 817 50 10-10 | SCREW 10-24 X .625 | 29 | 532 17 86-13 | WHEEL HUB |
| 3 | 532 43 60-80 | END PLATE | 30 | 874 76 05-14 | SCREW 5/16-18-.875 |
| 4 | 817 49 05-08 | SCREW 5/16-18 X .50 | 31 | 812 00 00-12 | RETAINER RING |
| 5 | 532 05 70-79 | WASHER | 32 | 532 40 21-87 | SPROCKET SHAFT |
| 6 | 532 40 54-85 | CONTROL ARM | 33 | 532 40 16-19 | CHAIN |
| 7 | 532 19 85-80 | CLEVIS PIN | 34 | 532 43 73-03 | SPROCKET WELDMENT |
| 8 | 532 41 54-50 | SHIFTER PLATE | 35 | 532 40 19-84 | SHIFTER BRACKET |
| 9 | 532 40 28-81 | SHOULDER BOLT | 36 | 532 18 01-35 | SPRING |
| 10 | 532 41 54-33 | SHIFTER BRACKET | 37 | 532 40 26-52 | PLATE PIVOT ROD |
| 11 | 532 19 17-30 | NUT 1/4-20 | 38 | 532 42 82-88 | E-RING .375 |
| 12 | 532 41 54-35 | CLUTCH PLATE | 39 | 532 18 44-71 | SHOULDER SCREW |
| 13 | 532 41 68-64 | CLUTCH BRACKET | 40 | 532 41 08-77 | BOTTOM PAN |
| 14 | 532 18 71-01 | SHIFTER LINK | 41 | 532 41 66-82 | SPRING BRACKET |
| 15 | 532 70 02-79 | RETAINER | 42 | 532 40 26-89 | DRIVE PLATE ASSEMBLY |
| 16 | 532 42 75-42 | CONTROL SHAFT | 43 | 532 41 45-57 | IDLER SPRING |
| 17 | 532 40 25-68 | CLUTCH ROD | 44 | 532 17 88-28 | IDLER SPRING |
| 18 | 532 16 96-75 | RETAINER | 45 | 532 40 25-04 | PULLEY SHAFT |
| 19 | 532 40 17-32 | SHIFTER YOKE | 46 | 532 40 18-20 | DRIVE PLATE |
| 20 | 532 40 23-10 | PIVOT ROD | 47 | 532 19 87-91 | BEARING |
| 21 | 812 00 00-36 | RETAINER | 48 | 532 40 23-93 | PULLEY HALF |
| 22 | 532 40 28-78 | RETURN SPRING | 49 | 817 54 10-08 | SCREW 10-24 X .50 |
| 23 | 532 75 11-53 | NUT 5/16-18 | 50 | 532 40 25-11 | SPACER BEARING |
| 24 | 532 40 89-81 | BEARING | 51 | 532 42 29-41 | SWING PLATE |
| 25 | 873 93 05-00 | NUT 5/16-18 | 52 | 532 13 20-10 | NUT 3/8-16 |
| 26 | 532 19 95-09 | RUBBER WHEEL PLATE | 53 | 532 42 88-67 | SCREW 5/16-18 X .750 |
| 27 | 532 44 06-20 | RUBBER RING | 54 | 817 00 05-10 | SCREW |

NOTE: All component dimensions given in U.S. inches. 1 inch = 25.4 mm

IMPORTANT: Use only Original Equipment Manufacturer (O.E.M.) replacement parts. Failure to do so could be hazardous, damage your snow thrower and void your warranty.

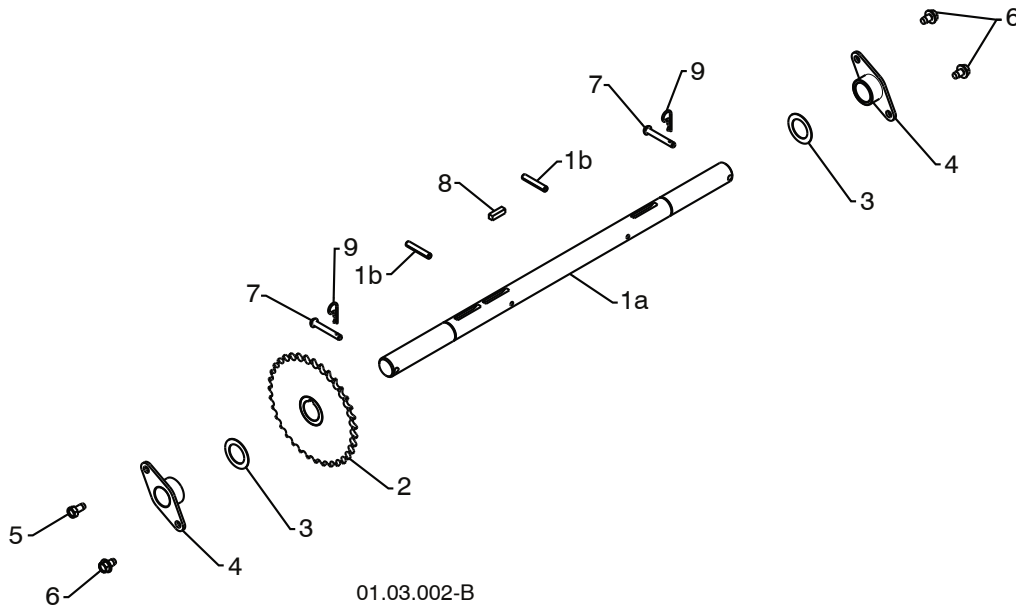

01.03.002-B

| KEY NO. | PART NO. | DESCRIPTION |
|---------|--------------|-------------------------------|
| 1 | 532 40 49-23 | AXLE ASSEMBLY (assy of 1a,1b) |
| 1a | 532 40 43-07 | AXLE SHAFT |
| 1b | 532 18 42-06 | ROLL PIN 3/16 X 1.50 |
| 2 | 532 40 26-91 | SPROCKET |
| 3 | 532 17 46-97 | THRUST WASHER |
| 4 | 532 17 98-30 | BEARING |
| 5 | 532 14 63-15 | SCREW 5/16-18 X .625 |
| 6 | 817 49 05-08 | SCREW 5/16-18 X .500 |
| 7 | 532 17 12-71 | CLEVIS PIN 1/4 X 1-3/4 |
| 8 | 532 18 92-82 | SQUARE KEY |
| 9 | 532 12 47-88 | RETAINER |

NOTE: All component dimensions given in U.S. inches. 1 inch = 25.4 mm
IMPORTANT: Use only Original Equipment Manufacturer (O.E.M.) replacement parts. Failure to do so could be hazardous, damage your snow thrower and void your warranty.

REPAIR PARTS

CHASSIS / PULLEYS

SNOW THROWER - MODEL NO. **ST 268EP** (96191003803), PRODUCT NO. 961 91 00-38

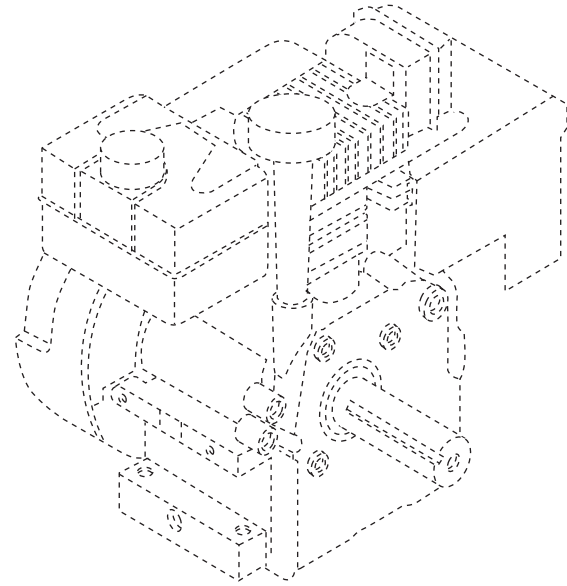
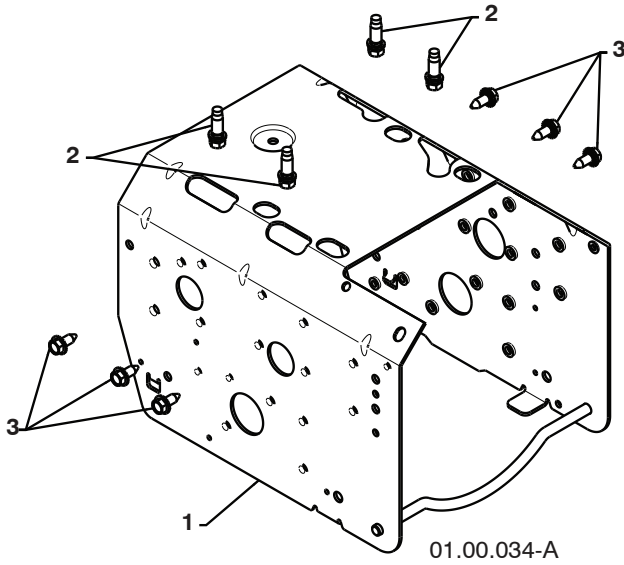

| KEY NO. | PART NO. | DESCRIPTION |
|---------|--------------|---------------------------|
| -- | ----- | B&S ENGINE 20M314-1479-H2 |
| 1 | 532 43 59-52 | FRAME |
| 2 | 532 15 04-06 | BOLT 3/8-16 |
| 3 | 532 42 88-67 | SCREW 5/16-18 X .750 |

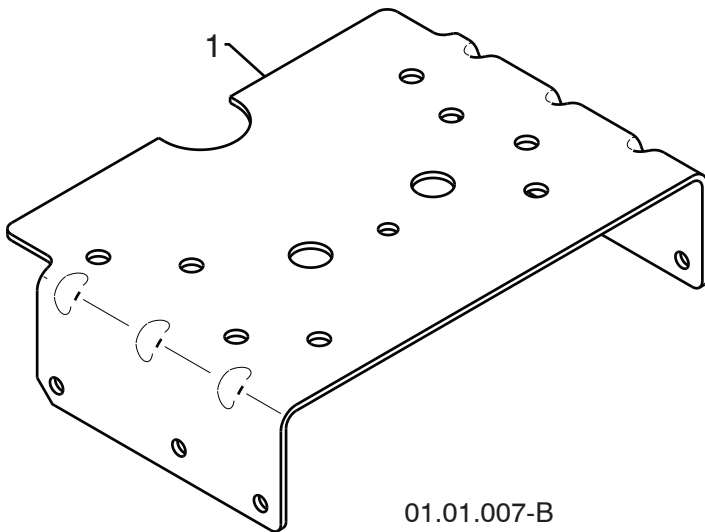

| KEY NO. | PART NO. | DESCRIPTION |
|---------|--------------|--------------------|
| 1 | 532 43 63-11 | ENGINE MOUNT PLATE |

NOTE: All component dimensions given in U.S. inches. 1 inch = 25.4 mm
IMPORTANT: Use only Original Equipment Manufacturer (O.E.M.) replacement parts.
 Failure to do so could be hazardous, damage your snow thrower and void your warranty.

REPAIR PARTS

CHASSIS / PULLEYS

SNOW THROWER - MODEL NO. **ST 268EP** (96191003803), PRODUCT NO. 961 91 00-38

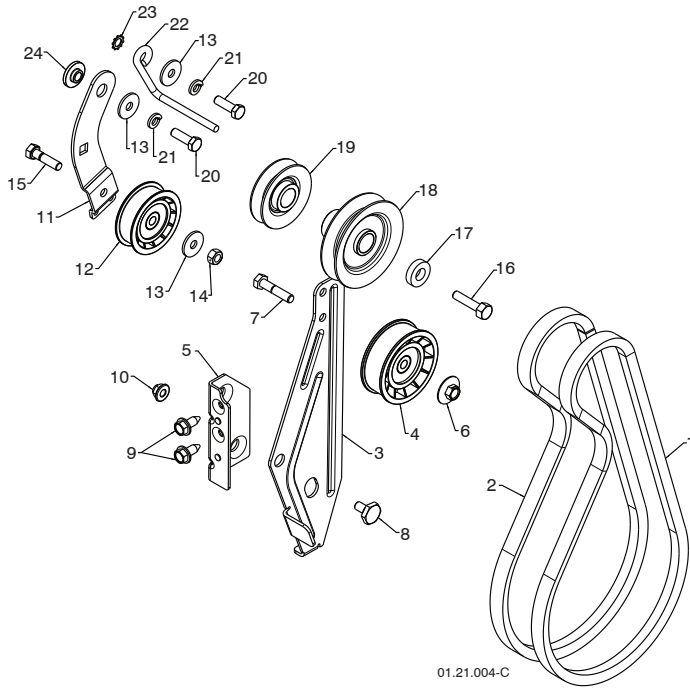

| KEY NO. | PART NO. | DESCRIPTION |
|---------|--------------|-----------------------------|
| 1 | 532 40 80-19 | IMPELLER BELT |
| 2 | 532 41 97-44 | TRACTION BELT |
| 3 | 532 42 92-71 | IDLER ARM BRACKET |
| 4 | 532 43 08-46 | IDLER PULLEY |
| 5 | 532 42 92-70 | IDLER ARM BRACKET |
| 6 | 532 42 65-89 | NUT 5/16-18 |
| 7 | 874 78 05-24 | SCREW 5/16-18 X 1.50 |
| 8 | 532 42 42-97 | SHOULDER BOLT 5/16-18 X .50 |
| 9 | 532 42 88-67 | SCREW 5/16-18 X .625 |
| 10 | 532 16 67-85 | NUT 5/16-18 NYLOCK |
| 11 | 532 18 77-86 | TRACTION IDLER BRACKET |
| 12 | 532 18 05-22 | TRACTION PULLEY |
| 13 | 532 05 92-89 | WASHER |
| 14 | 873 80 05-00 | NUT 5/16-18 |
| 15 | 874 78 05-20 | SCREW 5/16-18 X 1.25 |
| 16 | 532 85 10-84 | SCREW 3/8-24 X 1.375 |
| 17 | 532 40 00-26 | WASHER |
| 18 | 532 42 64-92 | PULLEY ENG IMPELLER |
| 19 | 532 42 64-90 | PULLEY ENG TRACTION |
| 20 | 874 61 05-16 | SCREW 5/16-24 X 1.00 |
| 21 | 810 04 05-00 | LOCKWASHER 5/16 |
| 22 | 532 15 54-52 | BELT GUIDE |
| 23 | 811 05 05-00 | LOCKWASHER 5/16 |
| 24 | 532 17 53-31 | IDLER BUSHING |

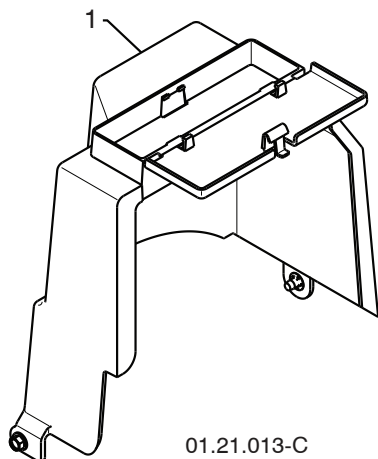

| KEY NO. | PART NO. | DESCRIPTION |
|---------|--------------|----------------|
| 1 | 532 44 30-30 | COVER ASSEMBLY |

NOTE: All component dimensions given in U.S. inches. 1 inch = 25.4 mm
IMPORTANT: Use only Original Equipment Manufacturer (O.E.M.) replacement parts.
 Failure to do so could be hazardous, damage your snow thrower and void your warranty.

REPAIR PARTS

WHEELS

SNOW THROWER - MODEL NO. **ST 268EP** (96191003803), PRODUCT NO. 961 91 00-38

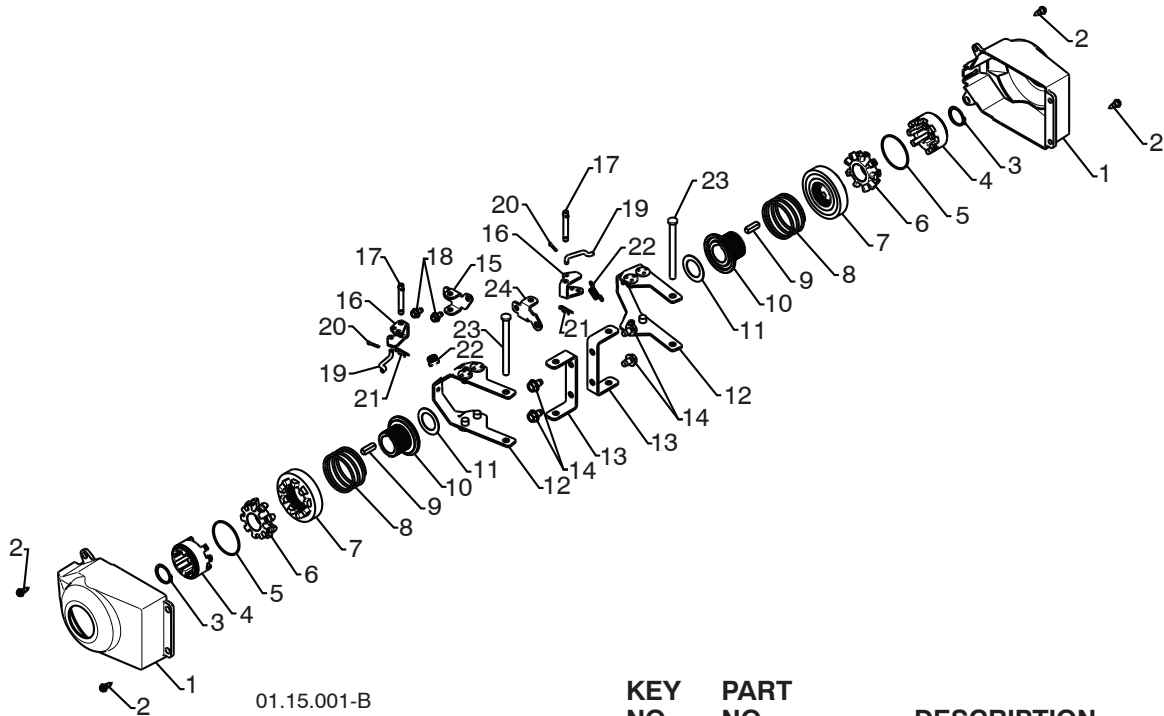

| KEY NO. | PART NO. | DESCRIPTION |
|---------|--------------|---------------------|
| 1 | 532 40 51-61 | COVER |
| 2 | 532 18 44-71 | SHOULDER SCREW |
| 3 | 812 00 00-45 | RETAINER RING |
| 4 | 532 19 21-26 | WHEEL DRIVER |
| 5 | 532 18 24-66 | RETAINER RING |
| 6 | 532 18 76-22 | WHEEL LOBE |
| 7 | 532 19 49-41 | CLUTCH SLIDE |
| 8 | 532 17 91-39 | SPRING |
| 9 | 532 18 92-82 | SQUARE KEY |
| 10 | 532 19 49-40 | AXLE LOBE |
| 11 | 532 17 46-97 | THRUST WASHER |
| 12 | 532 19 95-19 | STEERING YOKE |
| 13 | 532 18 41-97 | STEERING BRACKET |
| 14 | 817 49 05-08 | SCREW 5/16-18 X .50 |
| 15 | 532 19 95-11 | PIVOT BRACKET |
| 16 | 532 19 95-18 | BELLCRANK |
| 17 | 532 18 18-47 | BELLCRANK PIN |
| 18 | 817 60 04-06 | SCREW 1/4-20 X .375 |
| 19 | 532 40 50-77 | STEERING LINK |
| 20 | 532 70 02-79 | RETAINER |
| 21 | 532 08 51-79 | RETAINER |
| 22 | 532 19 38-85 | SPRING |
| 23 | 532 18 20-15 | LEVER PIN |
| 24 | 532 19 95-12 | PIVOT BRACKET |

NOTE: All component dimensions given in U.S. inches. 1 inch = 25.4 mm

IMPORTANT: Use only Original Equipment Manufacturer (O.E.M.) replacement parts. Failure to do so could be hazardous, damage your snow thrower and void your warranty.

REPAIR PARTS

WHEELS

SNOW THROWER - MODEL NO. **ST 268EP** (96191003803), PRODUCT NO. 961 91 00-38

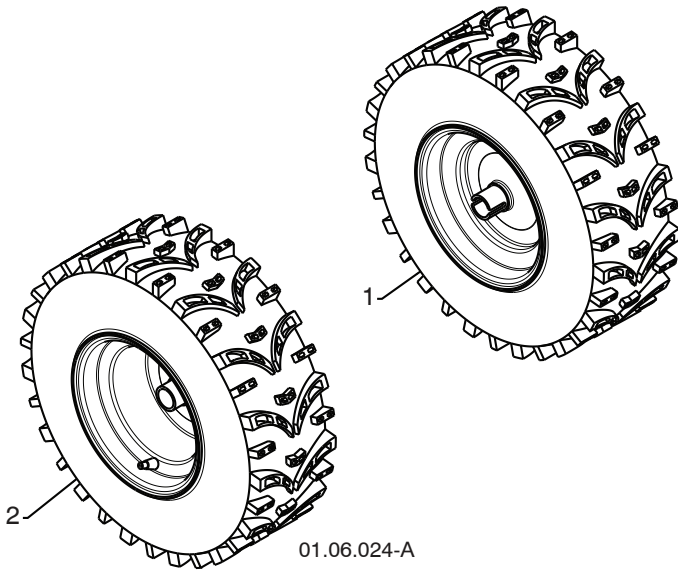

| KEY NO. | PART NO. | DESCRIPTION |
|---------|--------------|-------------------|
| 1 | 532 43 65-68 | WHEEL ASSEMBLY LH |
| 2 | 532 43 65-69 | WHEEL ASSEMBLY RH |

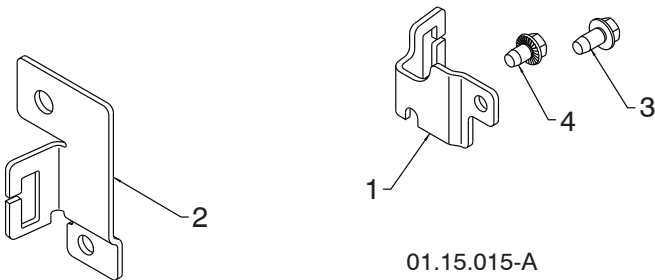

| KEY NO. | PART NO. | DESCRIPTION |
|---------|--------------|----------------------|
| 1 | 532 43 84-46 | CABLE BRACKET LH |
| 2 | 532 43 84-47 | CABLE BRACKET RH |
| 3 | 817 49 04-08 | SCREW 1/4 -20 X .500 |
| 4 | 817 60 04-06 | SCREW 1/4 -20 X .375 |

NOTE: All component dimensions given in U.S. inches. 1 inch = 25.4 mm
IMPORTANT: Use only Original Equipment Manufacturer (O.E.M.) replacement parts.
 Failure to do so could be hazardous, damage your snow thrower and void your warranty.

REPAIR PARTS

BAG OF PARTS

SNOW THROWER - MODEL NO. **ST 268EP** (96191003803), PRODUCT NO. 961 91 00-38

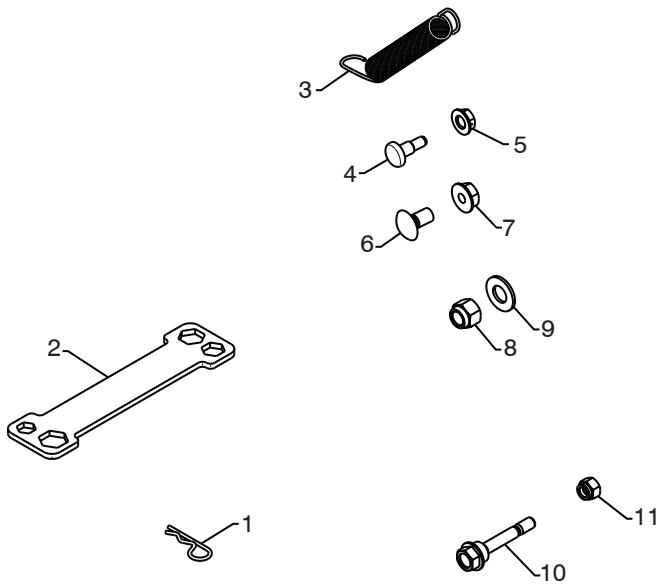

01.14.005-C

| KEY NO. | PART NO. | DESCRIPTION |
|---------|--------------|-----------------------------|
| 1 | 532 16 96-75 | RETAINER PIN |
| 2 | 532 42 91-12 | WRENCH |
| 3 | 532 18 45-05 | REMOTE SPRING |
| 4 | 532 17 98-29 | SHOULDER BOLT 1/4-20 |
| 5 | 532 19 17-30 | LOCKNUT 1/4-20 |
| 6 | 872 25 05-05 | CARRIAGE BOLT 5/16-18 X 5/8 |
| 7 | 532 75 11-53 | LOCKNUT 5/16-18 |
| 8 | 873 80 06-00 | LOCKNUT 3/8-16 |
| 9 | 819 13 13-16 | WASHER 3/8 |
| 10 | 532 19 20-90 | SHEAR BOLT 1/4-20 X 1-3/4 |
| 11 | 873 80 04-00 | LOCKNUT 1/4-20 |

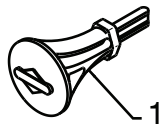

01.14.007-A

| KEY NO. | PART NO. | DESCRIPTION |
|---------|--------------|---------------------|
| 1 | 532 19 30-71 | SAFETY IGNITION KEY |

NOTE: All component dimensions given in U.S. inches. 1 inch = 25.4 mm
IMPORTANT: Use only Original Equipment Manufacturer (O.E.M.) replacement parts.
 Failure to do so could be hazardous, damage your snow thrower and void your warranty.

REPAIR PARTS

BAG OF PARTS

SNOW THROWER - MODEL NO. **ST 268EP** (96191003803), PRODUCT NO. 961 91 00-38

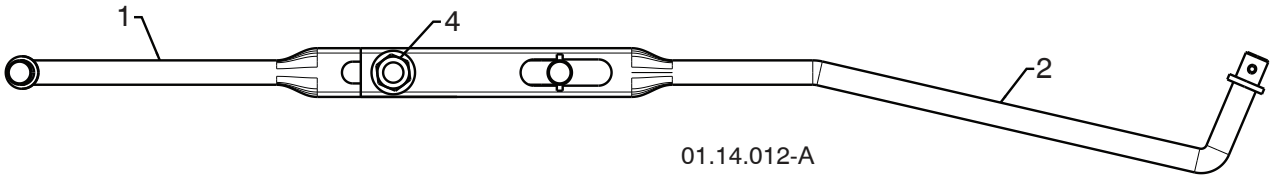
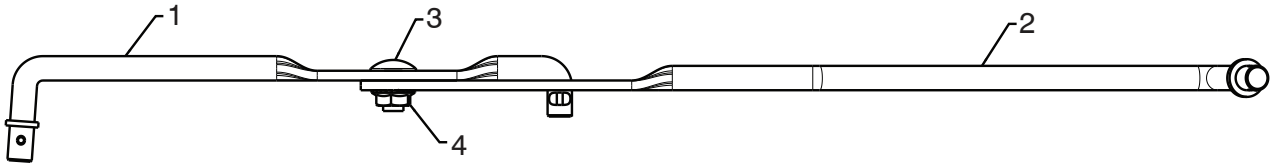

01.14.012-A

| KEY NO. | PART NO. | DESCRIPTION |
|---------|--------------|-----------------------------|
| 1 | 532 18 04-45 | SHIFTER ROD TOP |
| 2 | 532 18 77-16 | SHIFTER ROD BOTTOM |
| 3 | 872 27 05-05 | CARRIAGE BOLT 5/16-18 X .75 |
| 4 | 532 15 53-77 | NUT 5/16-18 |

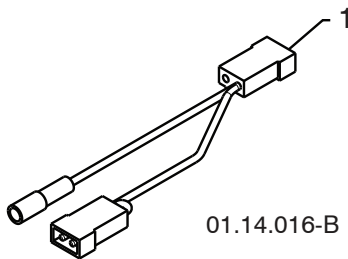

01.14.016-B

| KEY NO. | PART NO. | DESCRIPTION |
|---------|--------------|------------------|
| 1 | 532 43 58-40 | KIT HARNESS CONN |

NOTE: All component dimensions given in U.S. inches. 1 inch = 25.4 mm
IMPORTANT: Use only Original Equipment Manufacturer (O.E.M.) replacement parts.
 Failure to do so could be hazardous, damage your snow thrower and void your warranty.

REPAIR PARTS

DECALS

SNOW THROWER - MODEL NO. **ST 268EP** (96191003803), PRODUCT NO. 961 91 00-38

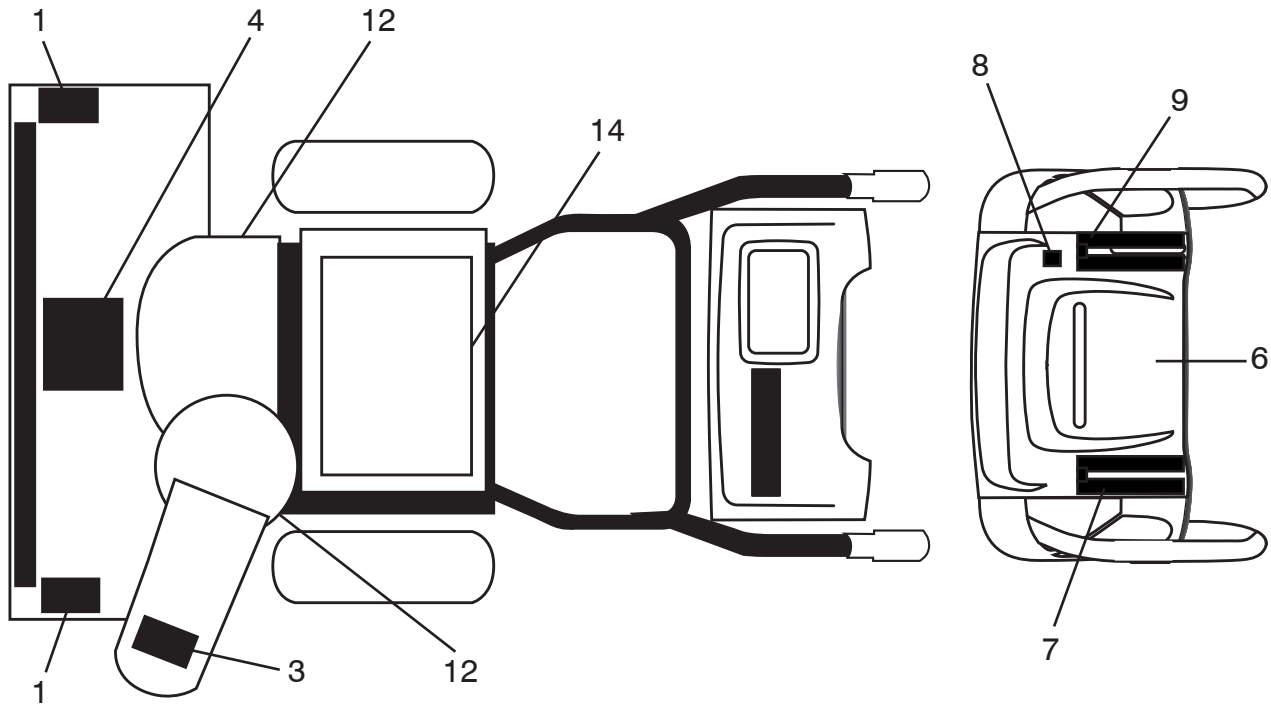

| KEY NO. | PART NO. | DESCRIPTION |
|---------|--------------|------------------------------|
| 1 | 532 19 96-83 | DECAL, DANGER |
| 3 | 532 19 96-82 | DECAL, DANGER, DEFLECTOR |
| 4 | 532 18 40-45 | DECAL, DANGER |
| 6 | 532 42 95-75 | DECAL, INSTURCTION |
| 7 | 532 42 95-69 | DECAL, TRACTION LEVER |
| 8 | 532 44 47-68 | DECAL, HANDWARMER |
| 9 | 532 42 95-71 | DECAL, SPEED CONTROL |
| 12 | 532 18 40-28 | DECAL, BELT GUARD |
| 14 | 532 18 04-33 | DECAL, SOUND LEVEL |
| -- | 532 44 37-35 | REPAIR PARTS MANUAL |
| -- | 532 44 30-80 | OPERATOR'S MANUAL, EURO |
| -- | 532 44 30-82 | OPERATOR'S MANUAL, SCAND |
| -- | 532 44 30-83 | OPERATOR'S MANUAL, EAST BLOC |
| -- | 532 44 30-78 | OPERATOR'S MANUAL, BALTIC |

NOTE: All component dimensions given in U.S. inches. 1 inch = 25.4 mm

IMPORTANT: Use only Original Equipment Manufacturer (O.E.M.) replacement parts. Failure to do so could be hazardous, damage your snow thrower and void your warranty.

