

ILLUSTRATED PARTS LIST

MODEL NO. 96041017003

CUSTOMER CATALOG NO. LT19538

PRODUCT NO. 960 41 01-70

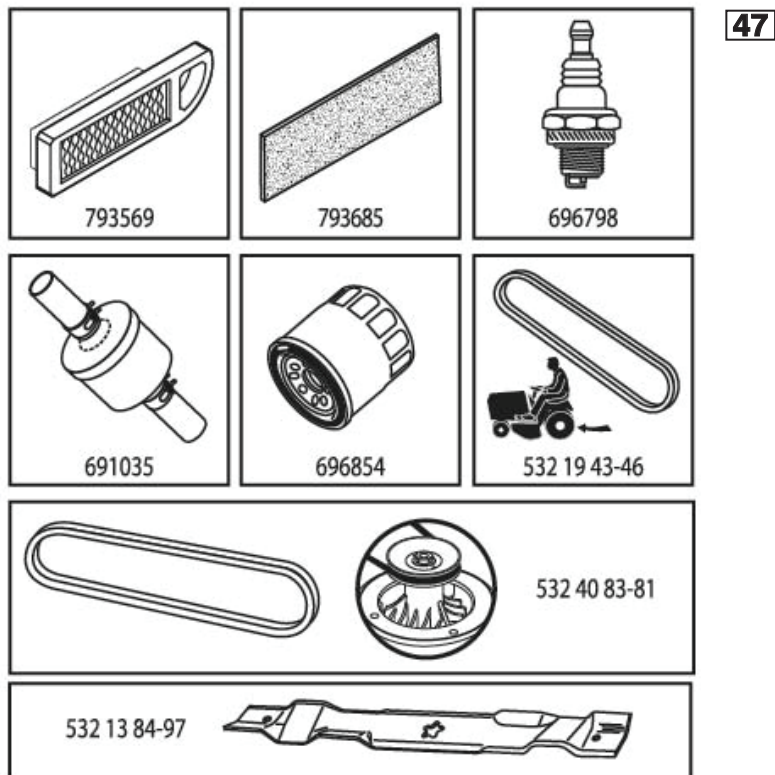

443834

**TRACTOR - - MODEL NO. LT19538 (96041017003), PRODUCT NO. 960 41 01-70
DECALS 27**

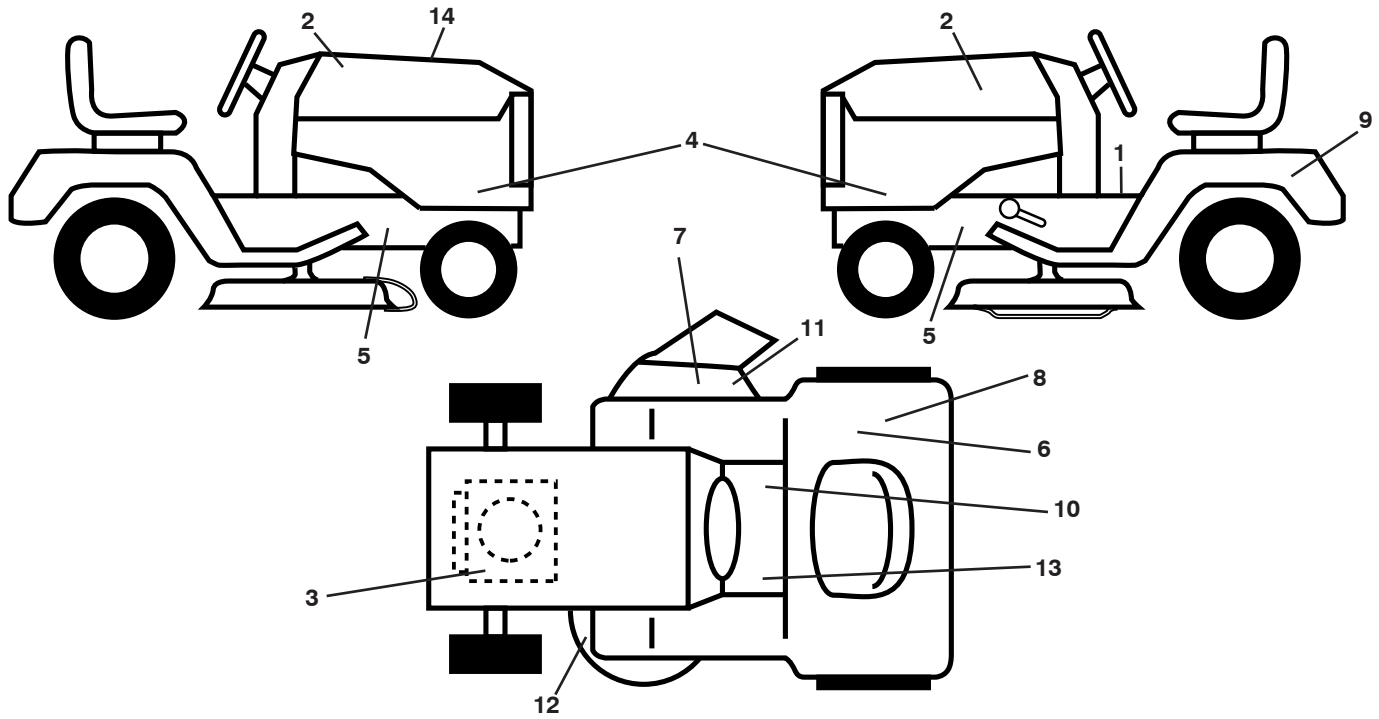

KEY NO.	PART NO.	DESCRIPTION
1	532 40 03-89	Decal, Operators
2	581 62 73-01	Decal, Hood
3	532 19 68-41	Decal, Warning Eng. Symbols
4	532 44 19-60	Decal, Hood Panel
5	532 15 97-36	Decal, Chassis Hot Muffler
6	532 12 44-33	Decal, 80 DBA
7	532 18 21-66	Decal, Cutfinger CE
8	532 16 88-69	Decal, Tick Mark
9	532 14 50-05	Decal, Battery Dnge/Poi

KEY NO.	PART NO.	DESCRIPTION
10	532 14 08-37	Decal, Saddle Brake Parking
11	532 19 63-57	Decal, Warning
12	532 19 43-02	Decal, Mower V-Belt Schematic
13	532 15 97-37	Decal, Brake/Clutch Symbol
14	532 44 38-34	Decal, Replacement
--	532 43 96-81	Pad, Footrest, LH
--	532 43 99-66	Pad, Footrest, RH
--	532 16 25-98	Decal, Drawbar Load Limit
--	532 44 40-09	Manual Oper. English

WHEELS AND TIRES

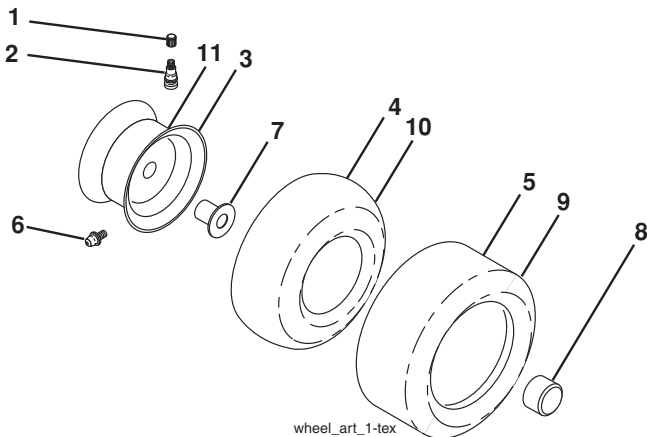

KEY NO.	PART NO.	DESCRIPTION
1	532 05 91-92	Cap Valve Tire
2	532 06 51-39	Stem Valve
3	532 13 83-36	Rim Asm 6" Front
4	532 05 99-04	Tube Front
5	532 43 71-54	Tire F T 15 x 6 0 - 6
6	532 12 49-57	Fitting Grease (Front Wheel Only)
7	532 12 49-59	Bearing Flange (Front Wheel Only)
8	532 17 50-39	Cap Axle Blk 1 50 x 1 00
9	532 42 05-31	Tire R 18 x 9.5-8 Turf Saver LT
10	532 12 49-26	Tube Rear
11	532 13 83-37	Rim Asm 8" Rear
--	532 14 43-34	Sealant, Tire (10 oz. Tube)

NOTE: All component dimensions given in U.S. inches
1 inch = 25.4 mm

TRACTOR - - MODEL NO. LT19538 (96041017003), PRODUCT NO. 960 41 01-70 SCHEMATIC **38**

SCH11

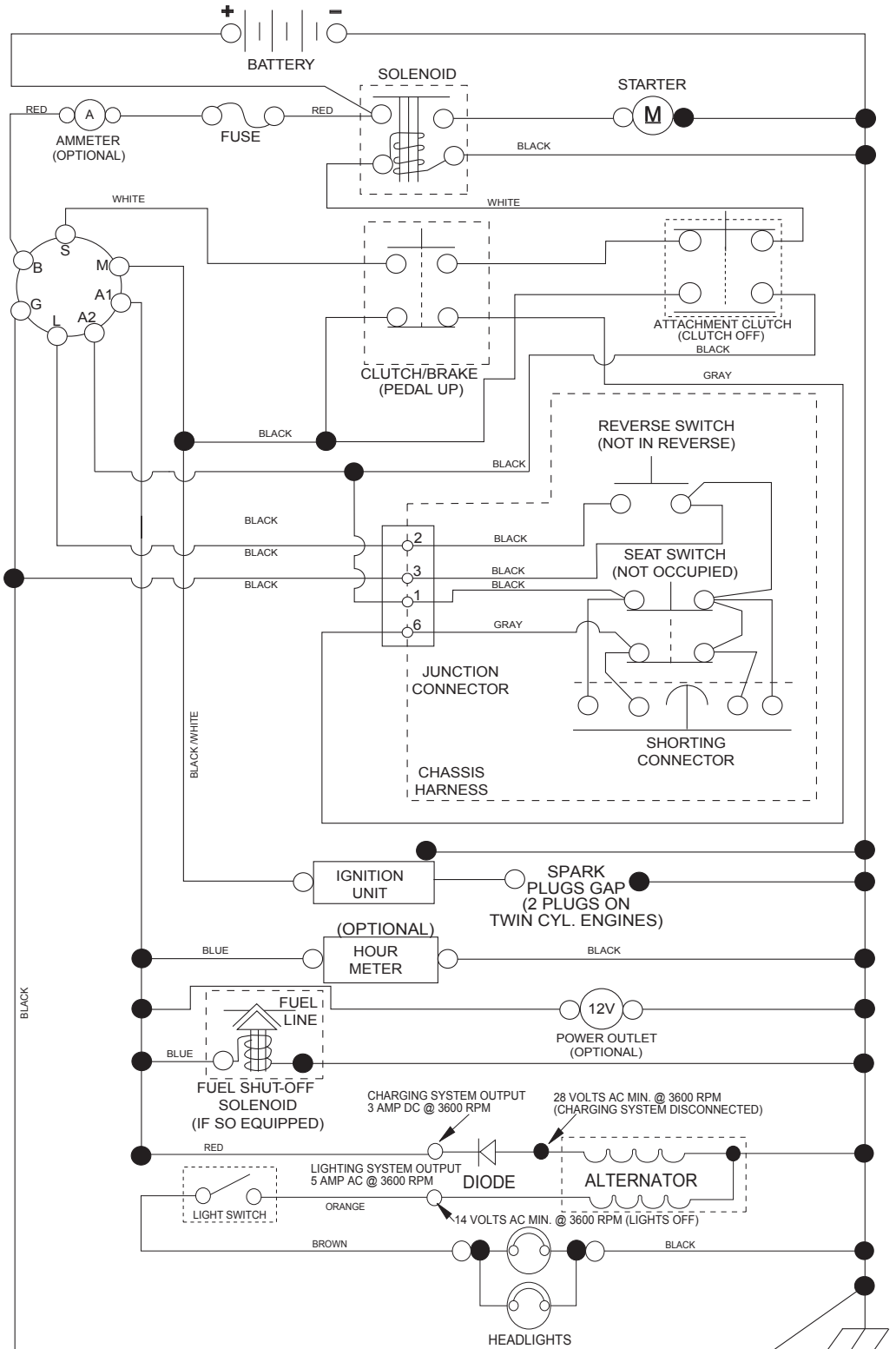

NOTE
YOUR TRACTOR IS EQUIPPED WITH A SPECIAL ALTERNATOR SYSTEM. THE LIGHTS ARE NOT CONNECTED TO THE BATTERY, BUT HAVE THEIR OWN ELECTRICAL SOURCE. BECAUSE OF THIS, THE BRIGHTNESS OF THE LIGHTS WILL CHANGE WITH ENGINE SPEED. AT IDLE THE LIGHTS WILL DIM. AS THE ENGINE IS SPEEDED UP, THE LIGHTS WILL BECOME THEIR BRIGHTEST.

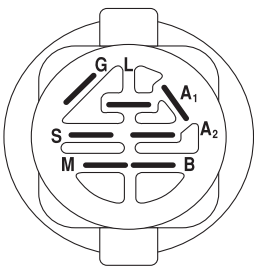

IGNITION SWITCH

POSITION	CIRCUIT "MAKE"
OFF	M+G+A1
RUN/OVERRIDE	B+A1
RUN	B+A1 L+A2
START	B + S + A1

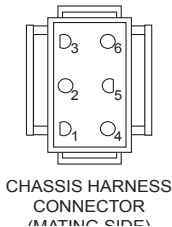

CHASSIS HARNESS CONNECTOR (MATING SIDE)

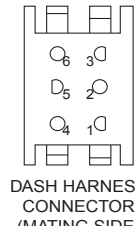

DASH HARNESS CONNECTOR (MATING SIDE)

WIRING INSULATED CLIPS
NOTE: IF WIRING INSULATED CLIPS WERE REMOVED FOR SERVICING OF UNIT, THEY SHOULD BE RE-INSTALLED TO PROPERLY SECURE YOUR WIRING.

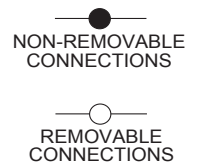

**TRACTOR - - MODEL NO. LT19538 (96041017003), PRODUCT NO. 960 41 01-70
ELECTRICAL 32**

T02S

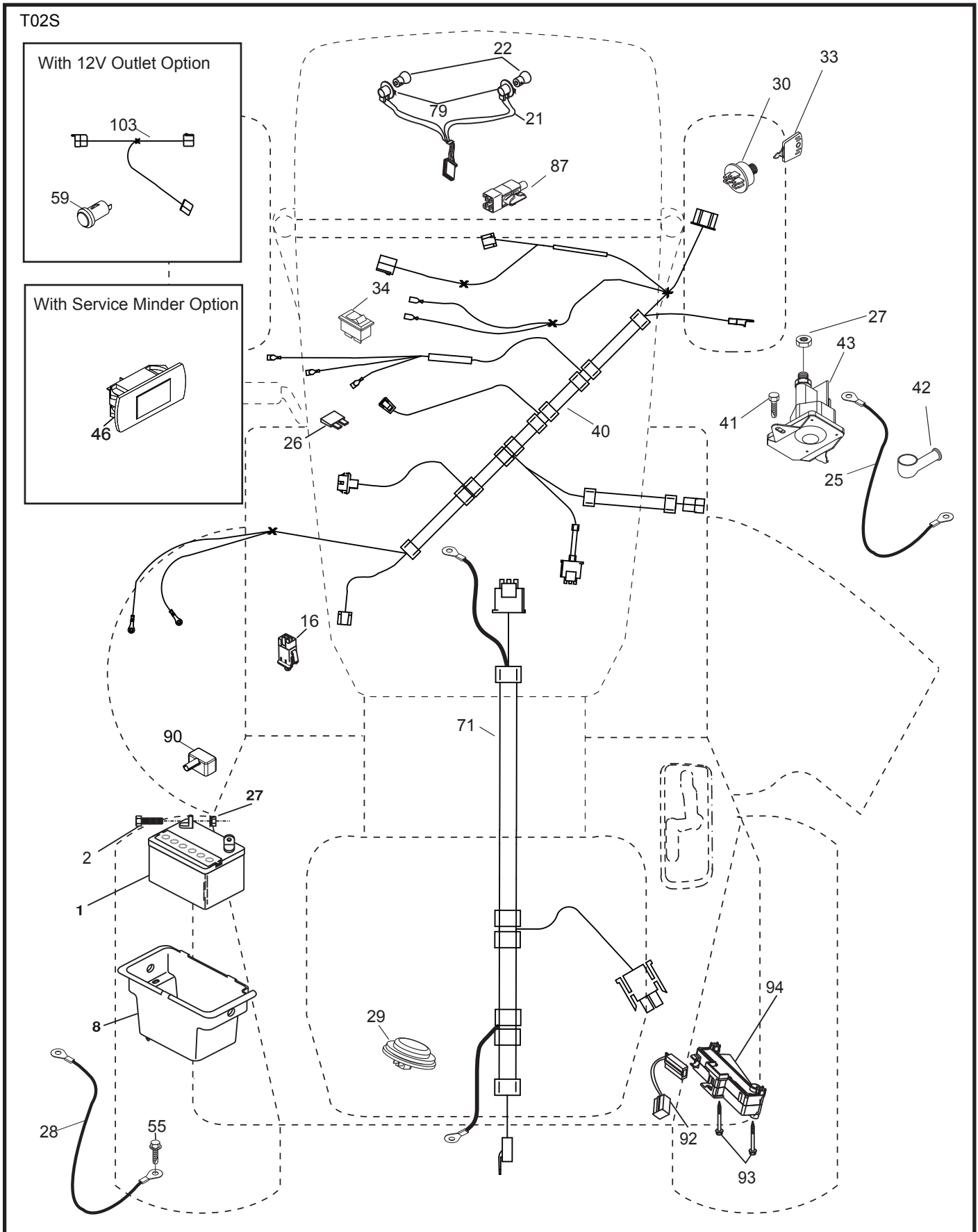

**TRACTOR - - MODEL NO. LT19538 (96041017003), PRODUCT NO. 960 41 01-70
ELECTRICAL 32**

KEY NO.	PART NO.	DESCRIPTION
1	532 16 34-65	Battery
2	874 76 04-12	Bolt Hex Head 1/4-20 x 3/4
8	532 19 32-28	Box Battery
16	532 17 61-38	Switch Interlock Push-In
21	532 40 02-52	Harness Socket Light w/4152J
22	532 00 41-52	Bulb Light
25	532 41 28-94	Cable Starter
26	532 17 51-58	Fuse
27	873 51 04-00	Nut Keps Hex 1/4-20 unc
28	532 19 88-85	Cable,Ground
29	532 40 15-45	Switch, Seat
30	532 19 33-50	Switch, Ign
33	532 41 19-33	Key, Ignition
34	532 11 07-12	Switch Light/Reset
40	532 40 10-98	Harness Ign. Dash
41	817 72 04-08	Screw Thd Cut 1/4-20 x 1/2
42	532 13 15-63	Cover, Terminal
43	532 19 25-07	Solenoid
46	532 40 17-63	Gauge Hourmeter
55	817 06 05-12	Screw Thdrol 5/16-18 x 3/4 TYTT
71	532 44 15-44	Harness Chassis
79	532 17 52-42	Socket Asm
87	532 19 78-02	Switch Interlock Clutch Cable
90	532 43 53-95	Cover Terminal
92	532 19 66-15	Harness Pigtail Reverse Switch
93	532 19 25-40	Screw Plastite 10-14 x 2.0
94	532 19 18-34	Module Reverse ROS

NOTE: All component dimensions given in U.S. inches
1 inch = 25.4 mm

TRACTOR - - MODEL NO. LT19538 (96041017003), PRODUCT NO. 960 41 01-70
CHASSIS AND ENCLOSURES **39**

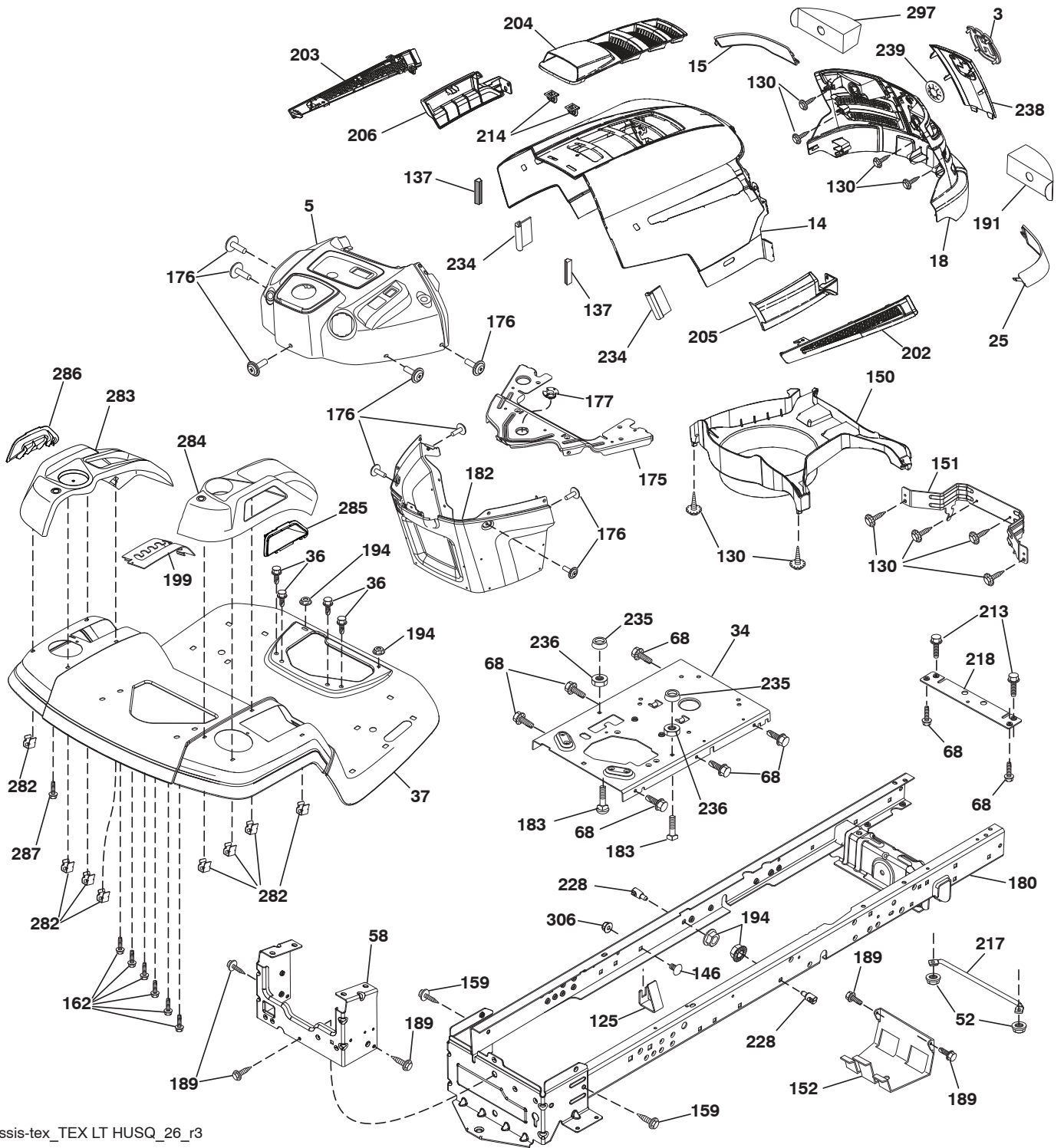

chassis-tex_TEX LT HUSQ_26_r3

**TRACTOR - - MODEL NO. LT19538 (96041017003), PRODUCT NO. 960 41 01-70
CHASSIS AND ENCLOSURES 39**

KEY NO.	PART NO.	DESCRIPTION	KEY NO.	PART NO.	DESCRIPTION
3	532 40 50-12	Logo	194	873 90 05-00	Nut Lock Hex Flange 5/16-18
5	532 43 89-64	Dash	199	532 41 34-85	Plate Deck Lift
14	532 44 12-67	Hood	202	532 44 13-42	Vent Side Hood RH
15	532 44 14-28	Lens LH	203	532 44 13-43	Vent Side Hood LH
18	532 44 13-68	Grille	204	532 44 13-75	Vent Top Hood
25	532 44 14-27	Lens RH	205	532 44 13-44	Skirt Side RH
34	532 19 61-25	Plate Engine	206	532 44 13-45	Skirt Side LH
36	817 06 05-12	Screw 5/16-18 x 3/4	213	874 76 05-12	Bolt 5/16-18 x 3/4
37	532 44 12-66	Fender	214	532 19 91-45	Clip Retainer
52	873 68 05-00	Nut Crown Lock 5/16	217	532 40 91-67	Rod Pivot Hood
58	532 41 22-80	Drawbar, Upper	218	532 19 63-95	X-Piece Hood Stop
68	817 49 05-08	Screw THDROL 5/16-18 x 1/2	228	532 19 51-61	Stud Fastener
125	581 68 48-01	Clip Fuel Line	234	532 40 47-42	Bumper Hood
130	532 41 63-58	Screw 10 x .750 BOSThread	235	532 40 61-29	Spacer Fender
137	532 40 75-90	Bumper Dash	236	873 93 05-00	Nut Lock 5/16-18 unc
146	581 85 79-01	Bolt	238	532 44 13-74	Trim
150	532 40 66-62	Air Duct	239	532 40 48-83	Clip Tinnerman
151	532 40 78-07	Bracket Pivot	282	532 41 41-10	Clip Retainer Console
152	532 19 95-35	Shield Browning	283	532 44 20-39	Console Deck Lift
159	817 00 06-12	Screw 3/8-7/16 x 3/4	284	532 44 33-30	Console Shift
162	532 14 24-32	Screw	285	532 41 63-15	Console Insert RH
175	532 19 94-72	Crossmember	286	532 41 63-17	Console Insert LH
176	532 40 07-76	Screw 10-24 x 5/8	287	817 60 04-06	Screw Hex Washhead 1/4-20 x 3/8
177	532 19 52-28	Bushing Steering	297	532 40 66-65	Insert Reflective LH
180	532 41 50-63	Chassis	306	873 90 06-00	Nut Lock
182	532 40 71-76	Dash Lower	- - -	532 40 09-44	Kit Bumper
183	874 52 05-20	Bolt 5/16-18 x 1-1/4			
189	817 00 05-12	Screw 5/16-18 x 3/4			
191	532 41 65-01	Insert Reflective RH			

NOTE: All component dimensions given in U.S. inches
1 inch = 25.4 mm

TRACTOR - - MODEL NO. LT19538 (96041017003), PRODUCT NO. 960 41 01-70
DRIVE **40**

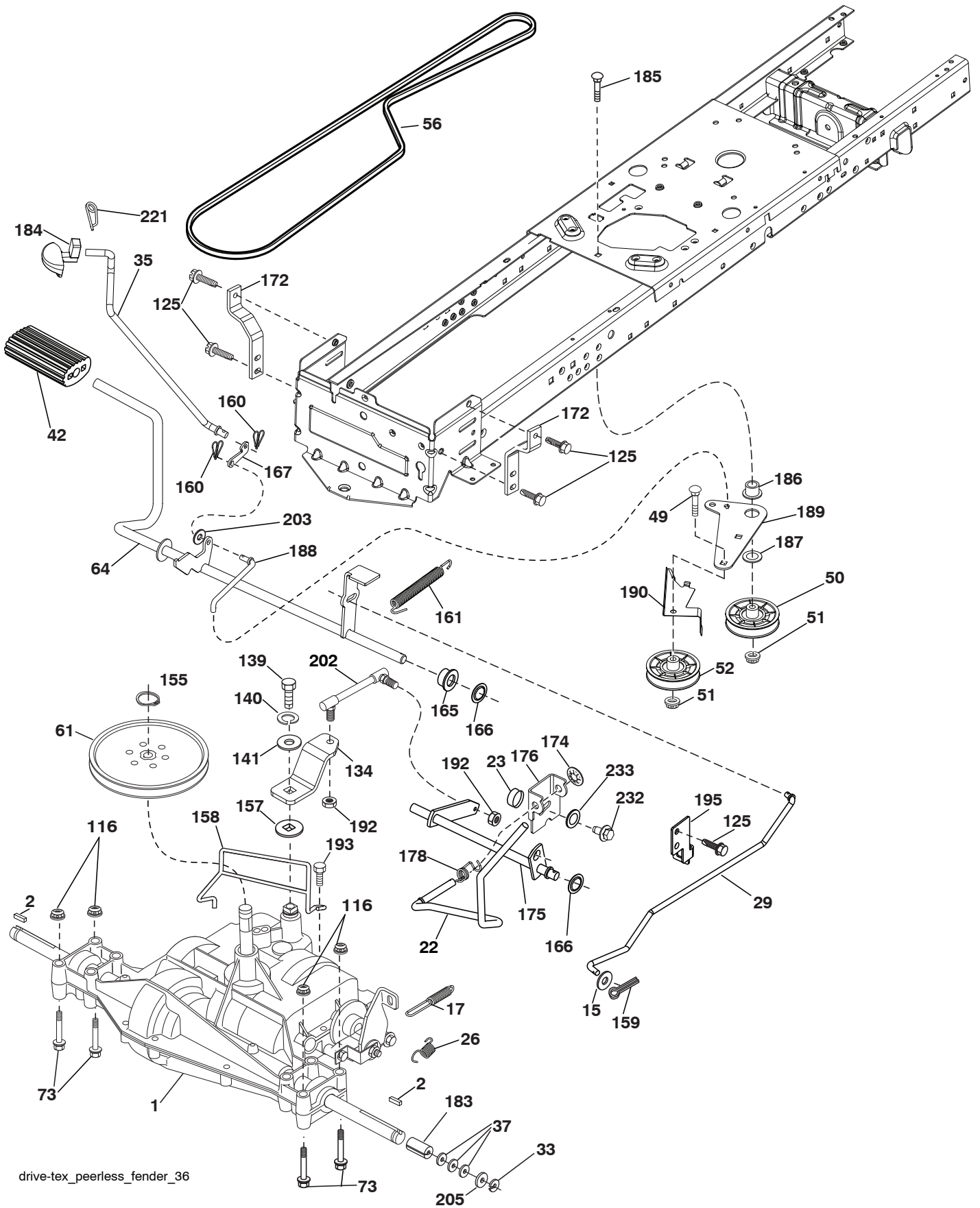

drive-tex_peerless_fender_36

**TRACTOR - - MODEL NO. LT19538 (96041017003), PRODUCT NO. 960 41 01-70
DRIVE **40****

KEY NO.	PART NO.	DESCRIPTION	KEY NO.	PART NO.	DESCRIPTION
1	- - - - -	Transaxle, Peerless 206-565 (197941) (Order parts from transaxle manufacturer)	160	532 16 94-84	Retainer Clip
2	532 12 35-83	Key Square	161	532 10 57-09	Spring, Return, Clutch
15	819 13 13-16	Washer 13/32 x 13/16 x 16 Ga.	165	532 19 62-12	Bushing Shaft Brake Hand Control
17	532 19 72-97	Spring, Brake	166	532 42 91-64	Nut Push .625
22	532 19 76-60	Rod Shift	167	532 40 52-57	Latch Brake Parking
23	532 12 12-74	Knob Duckhead 1/2-13	172	532 19 76-57	Strap Torque LH
26	532 19 74-55	Spring Brake Return	174	532 19 72-89	Nut Push
29	532 19 72-67	Rod, Brake	175	532 19 78-58	Shaft Asm. Shift
33	812 00 00-01	Ring E	176	532 19 62-14	Arm Clevis Rod Shift
35	532 40 10-31	Rod, Brake, Park	178	532 19 74-56	Spring Shift
37	532 12 17-49	Washer 25/32 x 1-1/4 x 16 Ga.	183	532 13 70-57	Spacer Axle
42	532 12 48-72	Cover, Foot Pedal	184	532 44 14-07	Knob
49	872 11 06-14	Bolt	185	872 11 06-22	Bolt
50	532 19 43-27	Pulley Idler Flat	186	532 19 43-21	Spacer Retainer
51	873 90 06-00	Lock Nut 3/8-16	187	819 13 32-10	Washer
52	532 19 43-26	Idler V-Groove	188	532 19 43-23	Link Clutch Ground Drive
56	532 19 43-46	V-Belt, Drive	189	532 19 43-17	Bellcrank Ground Drive
61	532 12 36-66	Pulley transaxle	190	532 19 43-18	Keeper Bellcrank Ground Drive
64	532 19 62-00	Shaft Asm. Pedal Brake Control	192	532 15 03-60	Nut Lock Center 1/4-28 Fnthd
73	874 49 05-44	Belt 5/16-18 Gr. 5	193	817 06 05-12	Screw 5/16-18 x 3/4
116	873 90 05-00	Nut Lock Hex Flange 5/16-18	195	532 19 73-32	Bracket Brake Rod
125	817 00 05-12	Screw 5/16-18 x 3/4	202	532 19 78-59	Link Transaxle
134	532 19 78-57	Asm Shift	203	819 11 11-16	Washer 11/32 x 11/16 x 16 Ga.
139	874 55 04-12	Bolt 1/4-28 unf Gr. 8 w/Patch	205	532 12 17-48	Washer 25/32 x 1-5/8 16 Ga.
140	810 04 04-00	Washer Lock Hvy Helical 1/4	221	532 40 31-87	Retainer Spring Clip Handle
141	819 09 12-10	Washer 9/32 x 3/4 x 10 Ga.	232	874 78 07-16	Bolt Fin Hex 7/16-14 x 1 Gr 5
155	812 00 00-28	Ring Retainer	233	532 40 52-96	Washer Serrated
157	532 10 57-01	Washer Plate Shift			
158	532 19 43-52	Belt Keeper			
159	876 02 04-12	Pin Cotter 1/8 x 3/4			

NOTE: All component dimensions given in U.S. inches
1 inch = 25.4 mm

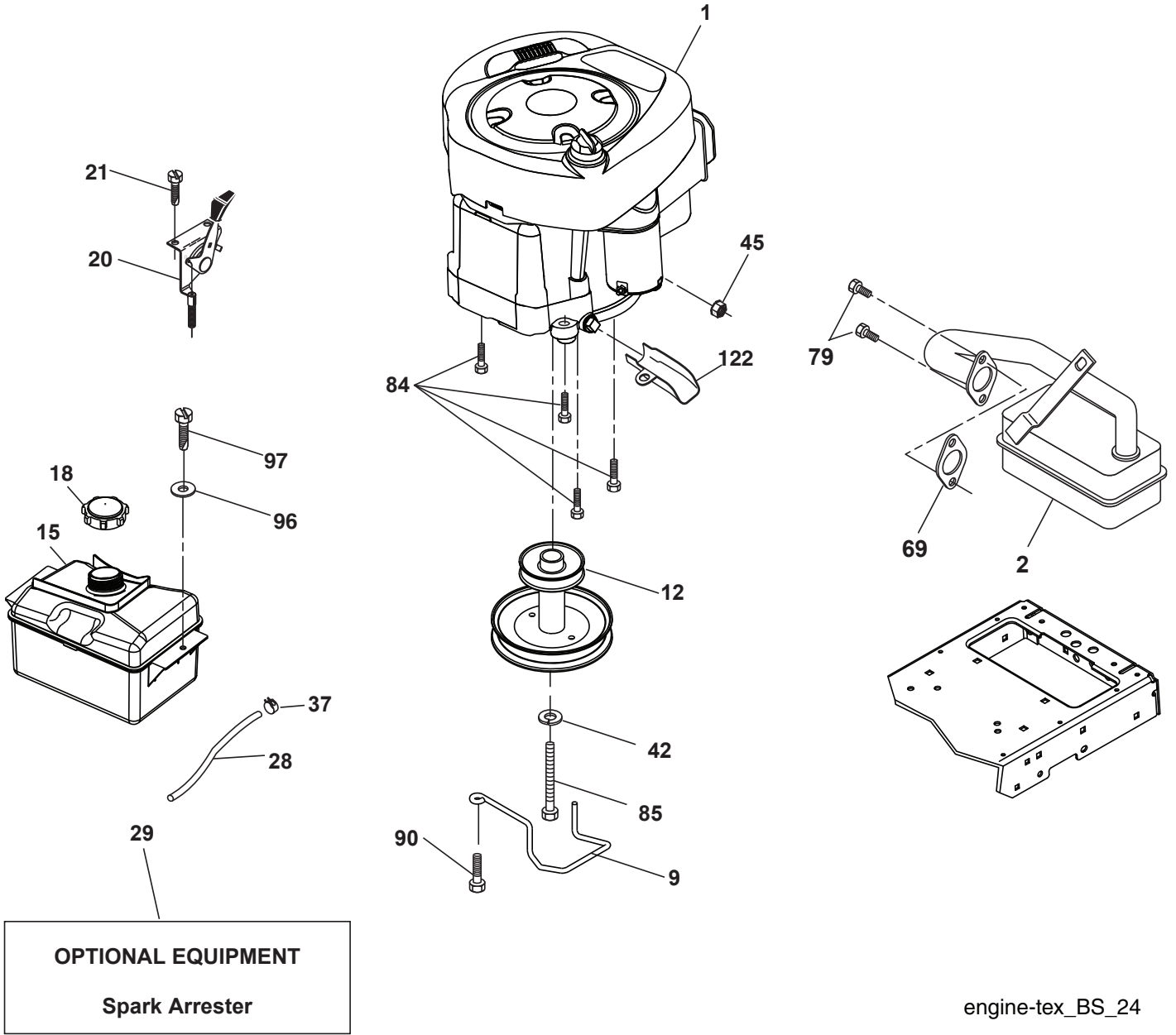

**TRACTOR - - MODEL NO. LT19538 (96041017003), PRODUCT NO. 960 41 01-70
ENGINE 24**

KEY NO.	PART NO.	DESCRIPTION
1	- - - - -	Engine B&S Model No. 31Q677-3493-G1 (438681) (Order parts from engine manufacturer)
2	532 13 73-52	Muffler
9	532 19 43-19	Keeper Belt Engine
12	532 40 19-85	Pulley Engine
15	532 40 75-45	Tank Fuel 1.5
18	532 43 02-20	Cap Asm
20	532 18 38-97	Control Throttle
21	532 41 63-58	Screw #10 x 0.075
28	532 13 70-40	Fuel Line
29	532 13 71-80	Spark Arrester Kit
37	532 12 34-87	Clamp Hose
42	810 04 07-00	Washer Split
45	873 51 04-00	Nut Keps Hex 1/4-20 unc
69	532 16 52-91	Gasket
79	532 19 23-34	Screw 5/16-18 x .75
84	817 06 06-20	Screw 3/8-16 x 1-1/4
85	532 17 39-37	Bolt Hex 7/16-20 x 4 Gr. 5
90	817 00 06-16	Screw 3/8-16 x 1
96	819 09 14-16	Washer 9/32 x 7/8 x 16 Ga.
97	817 67 04-12	Screw 1/4-20 x 3/4
122	532 42 19-22	Extension Drain Oil

NOTE: All component dimensions given in U.S. inches
1 inch = 25.4 mm

Engine Power Rating Information

The gross power rating for individual gas engine models is labeled in accordance with SAE (Society of Automotive Engineers) code J1940 (Small Engine Power & Torque Rating Procedure), and rating performance has been obtained and corrected in accordance with SAE J1995 (Revision 2002-05). Torque values are derived at 3060 RPM; horsepower values are derived at 3600 RPM. Actual gross engine power will be lower and is affected by, among other things, ambient operating conditions and engine-to-engine variability. Given both the wide array of products on which engines are placed and the variety of environmental issues applicable to operating the equipment, the gas engine will not develop the rated gross power when used in a given piece of power equipment (actual “on-site” or net power). This difference is due to a variety of factors including, but not limited to, accessories (air cleaner, exhaust, charging, cooling, carburetor, fuel pump, etc.), application limitations, ambient operating conditions (temperature, humidity, altitude), and engine-to-engine variability. Due to manufacturing and capacity limitations, Briggs & Stratton may substitute an engine of higher rated power for this Series engine.

TRACTOR - - MODEL NO. LT19538 (96041017003), PRODUCT NO. 960 41 01-70
STEERING ASSEMBLY **41**

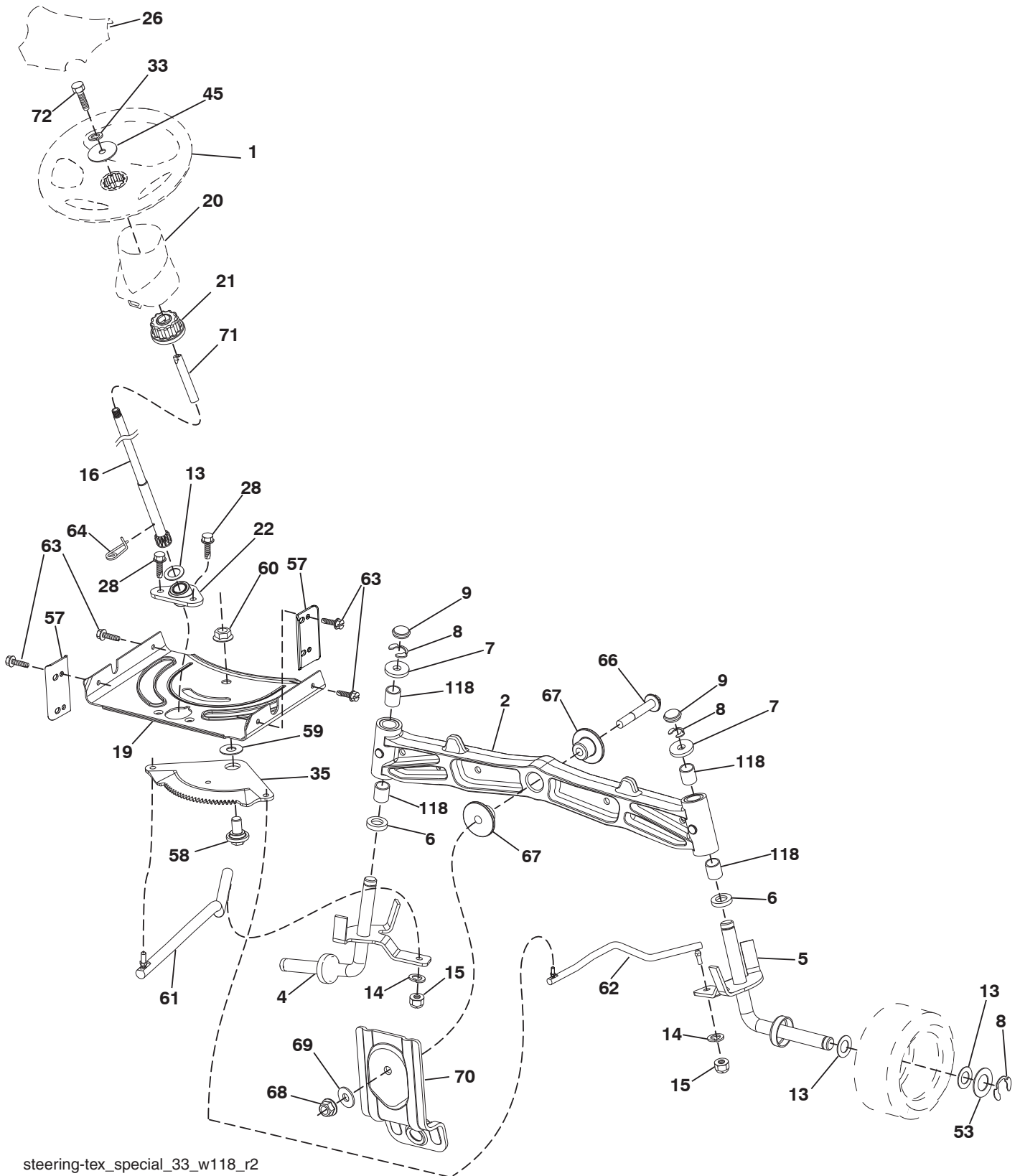

steering-tex_special_33_w118_r2

**TRACTOR - - MODEL NO. LT19538 (96041017003), PRODUCT NO. 960 41 01-70
STEERING ASSEMBLY 41**

KEY NO.	PART NO.	DESCRIPTION
1	532 43 97-40	Wheel, Steering
2	532 41 35-91	Axle Asm., Front
4	532 40 30-87	Spindle Asm., LH
5	532 40 30-88	Spindle Asm., RH
6	532 12 49-31	Washer .75 x 1.230, Thrust
7	532 12 17-48	Washer 25/32 x 1-5/8 x 16 Ga.
8	812 00 00-29	Ring, clip #T5304-75
9	532 12 12-32	Cap, Spindle
13	532 12 17-49	Washer 25/32 x 1-1/4 x 16 Ga.
14	810 04 06-00	Washer, Lock Hvy Hlcl Spr 3/8
15	873 54 06-00	Nut, Crown Lock 3/8-24 unf
16	532 42 93-73	Shaft Steering
19	532 19 47-29	Plate Steering
20	532 44 14-25	Boot, Steering
21	532 18 67-37	Adapter, Wheel Steering
22	532 42 05-37	Steering Support Lower
26	532 43 97-43	Insert, Wheel Steering
28	817 00 06-12	Screw 3/8-16 x 3/4
33	810 04 05-00	Washer Lock 5/16
35	532 19 47-32	Gear, Sector Plate
45	819 11 38-12	Washer 11/32 x 3/8 x 12 Ga.
53	532 18 89-67	Washer Hardened .793 x 1.637 x .060
57	532 40 74-65	Bracket Upstop
58	532 19 47-47	Bolt Shoulder Sector Pivot CFM
59	532 19 47-48	Washer Thrust Sector Steering
60	873 97 10-00	Nut Flange Lock 5/8-11
61	532 19 47-40	Draglink, LH
62	532 19 47-41	Draglink, RH
63	817 00 05-12	Screw 5/16-18 x 3/4
64	532 19 98-49	Retainer Clip Spring Steering
66	871 02 07-48	Bolt Hex Fghd 7/16-14 x 3 Serr
67	532 19 47-37	Bushing PM Front Axle
68	873 90 07-00	Nut Lock Flange 7/16-14 Gr. 5
69	532 19 91-62	Washer 1.5 x .505 x .118
70	532 19 61-97	Bracket Deck Susp. Front
71	532 19 07-52	Shaft Extension Steering
72	532 42 89-82	Bolt Fin Hex 5/16-18 x 4 w/Patch
118	532 40 60-13	Bushing

NOTE: All component dimensions given in U.S. inches
1 inch = 25.4 mm

TRACTOR - - MODEL NO. LT19538 (96041017003), PRODUCT NO. 960 41 01-70
MOWER DECK **44**

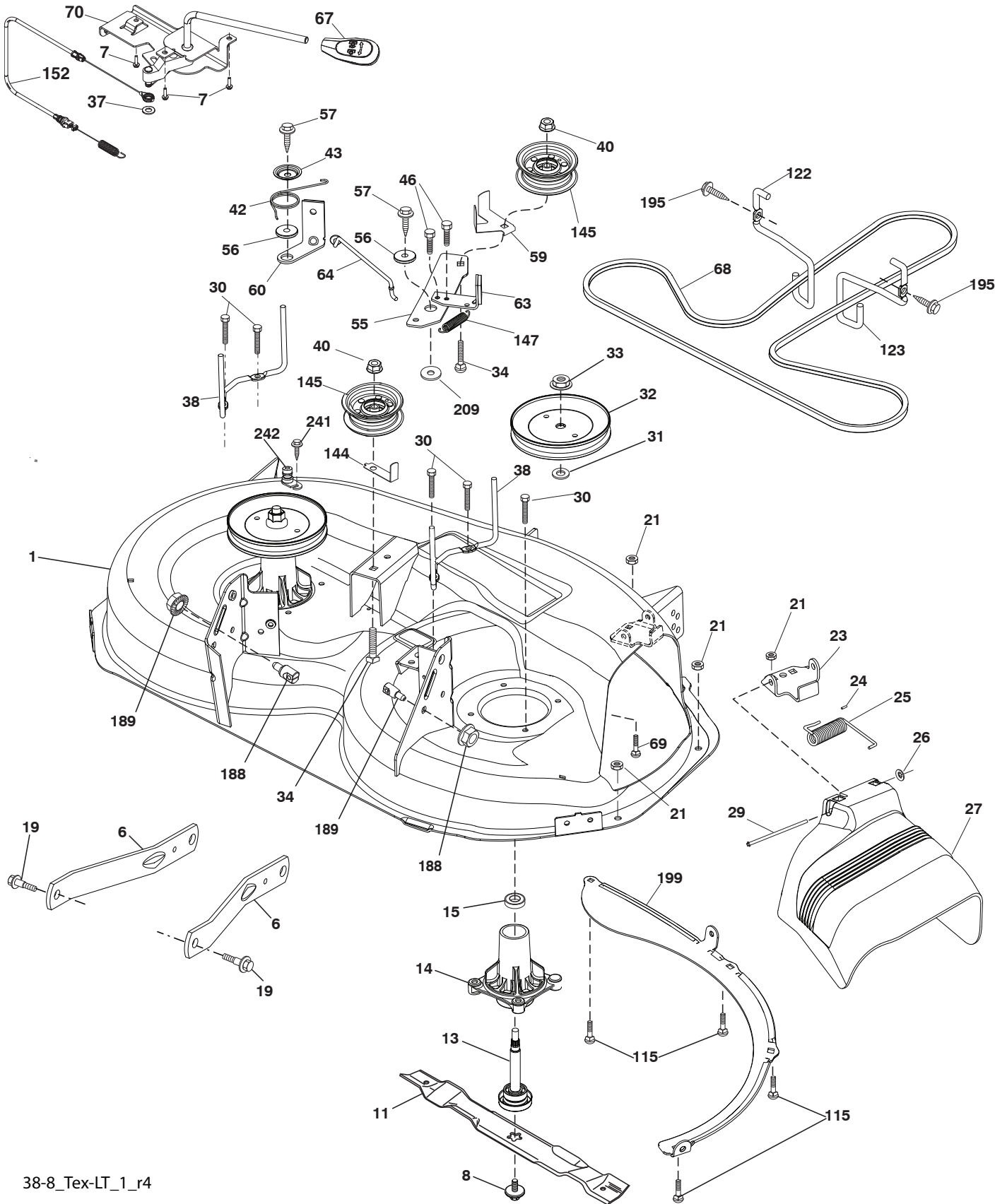

38-8_Tex-LT_1_r4

TRACTOR - - MODEL NO. LT19538 (96041017003), PRODUCT NO. 960 41 01-70
MOWER DECK 44

KEY NO.	PART NO.	DESCRIPTION	KEY NO.	PART NO.	DESCRIPTION
1	532 44 41-63	Mower Housing	59	532 14 10-43	Guard, Tuv Idler
6	532 19 51-86	Arm Suspension	60	532 19 94-71	Arm Brake Mower
7	532 41 63-58	Screw #10 x 0.750 BOS Thread	63	532 19 94-70	Arm Brake Mower
8	532 19 30-03	Bolt/Washer Asm 7/16-20 unf	64	532 19 97-90	Link Brake
11	532 13 84-97	Blade	67	532 40 30-12	Handle Clutch Cable
13	532 19 28-72	Shaft Assembly Mandrel	68	532 40 83-81	V-Belt
14	532 18 72-81	Housing Mandrel	69	872 14 05-05	Bolt
15	532 11 04-85	Bearing, Ball, Mandrel	70	532 40 12-46	Clutch Asm Manual
19	532 19 65-39	Bolt, Shoulder	115	872 11 05-05	Bolt 5/16-18 x 5/8
21	873 68 05-00	Nut, Crownlock 5/16-18 unc	122	532 19 72-58	Keeper Belt Engine LH
23	532 19 25-57	Bracket, Deflector	123	532 19 72-59	Keeper Belt Engine RH
24	532 10 53-04	Cap, Sleeve	144	532 19 34-14	Keeper Belt
25	532 19 70-26	Spring, Torsion, Deflector	145	532 19 31-97	Pulley Idler
26	532 11 04-52	Nut, Push	147	532 40 18-72	Spring Return
27	532 19 39-68	Shield, Deflector	152	532 43 51-11	Manual Clutch Cable
29	532 13 14-91	Rod, Hinge	188	532 19 51-61	Stud Fastener
30	532 17 39-84	Screw Thdrol Rolling Wsh Hd	189	873 90 05-00	Nut Lock Hex Flange
31	532 18 76-90	Washer, Spacer	195	817 00 06-12	Screw 3/8-16 x 3/4
32	532 19 97-89	Pulley, Mandrel	199	532 40 00-95	Baffle Vortex
33	532 40 02-34	Nut, Toplock, Flanged	209	819 13 32-10	Washer 13/32 x 2 x 10
34	872 11 06-12	Bolt Carr Sh. 3/8-16 x 1-1/2 Gr. 5	241	532 15 29-27	Screw
37	819 13 13-16	Washer	242	532 41 55-98	Port Washout
38	532 19 95-41	Keeper Belt LH Mandrel	--	532 19 28-70	Mandrel Assembly (Includes housing, shaft assembly, and bearing only - pulley/nut/washer and blade bolt/washers not included)
40	873 90 06-00	Nut, Lock Flg. 3/8-16 unc	--	532 43 44-67	Replacement Mower, Complete
42	532 19 84-10	Spring Torsion Brake			
43	532 19 72-56	Spring Torsion Retainer			
46	532 13 77-29	Screw 1/4-20 x 5/8			
55	532 19 72-49	Arm, Idler			
56	532 19 90-92	Spacer, Retainer			
57	817 00 06-16	Screw 3/8-16 x 1			

NOTE: All component dimensions given in U.S. inches
1 inch = 25.4 mm

TRACTOR - - MODEL NO. LT19538 (96041017003), PRODUCT NO. 960 41 01-70
MOWER LIFT 45

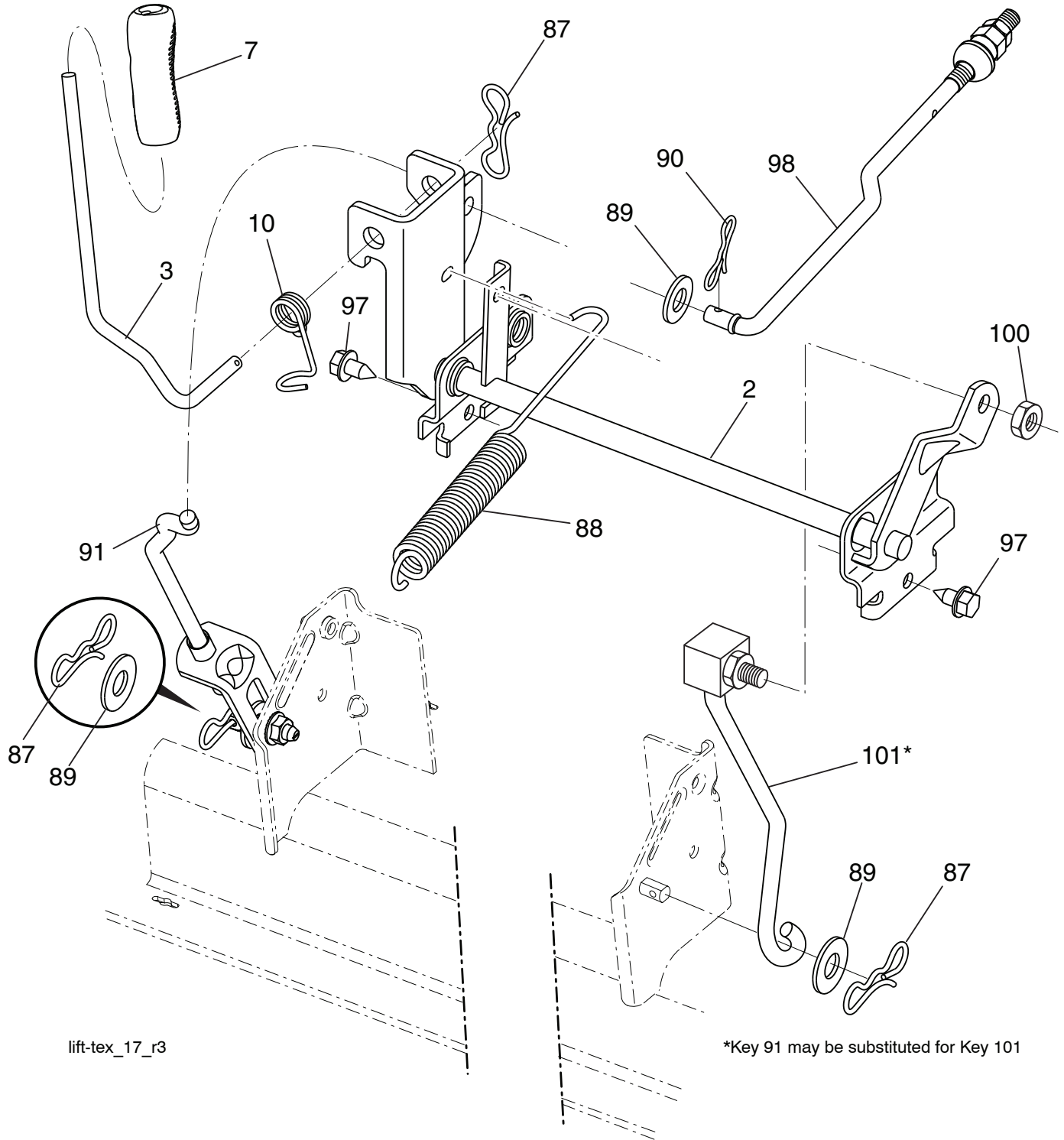

lift-tex_17_r3

KEY NO.	PART NO.	DESCRIPTION
2	532 42 20-27	Shaft Asm., Lift
3	532 19 52-31	Lever Asm., Lift RH
7	532 41 15-55	Grip, Lever
10	532 19 63-14	Spring Torsion
87	532 19 42-09	Pin Cotter 7/16 Bow Tie Lock
88	532 41 07-10	Spring Lift Assist
89	819 19 19-12	Washer Clear Zinc
90	532 19 42-08	Pin Cotter 5/16 Bow Tie Lock
91	532 19 51-81	Link Lift Susp Mower Rear

KEY NO.	PART NO.	DESCRIPTION
97	817 00 06-12	Screw 3/8-16 x .75 Smgml Tap/R.Z
98	532 19 52-70	Link Lift Susp. Front Mower
100	873 93 06-00	Nut Centerlock 3/8-16
101	532 40 70-03	Link Asm. Lift

NOTE: All component dimensions given in U.S. inches
 1 inch = 25.4 mm

**TRACTOR - - MODEL NO. LT19538 (96041017003), PRODUCT NO. 960 41 01-70
SEAT ASSEMBLY 42**

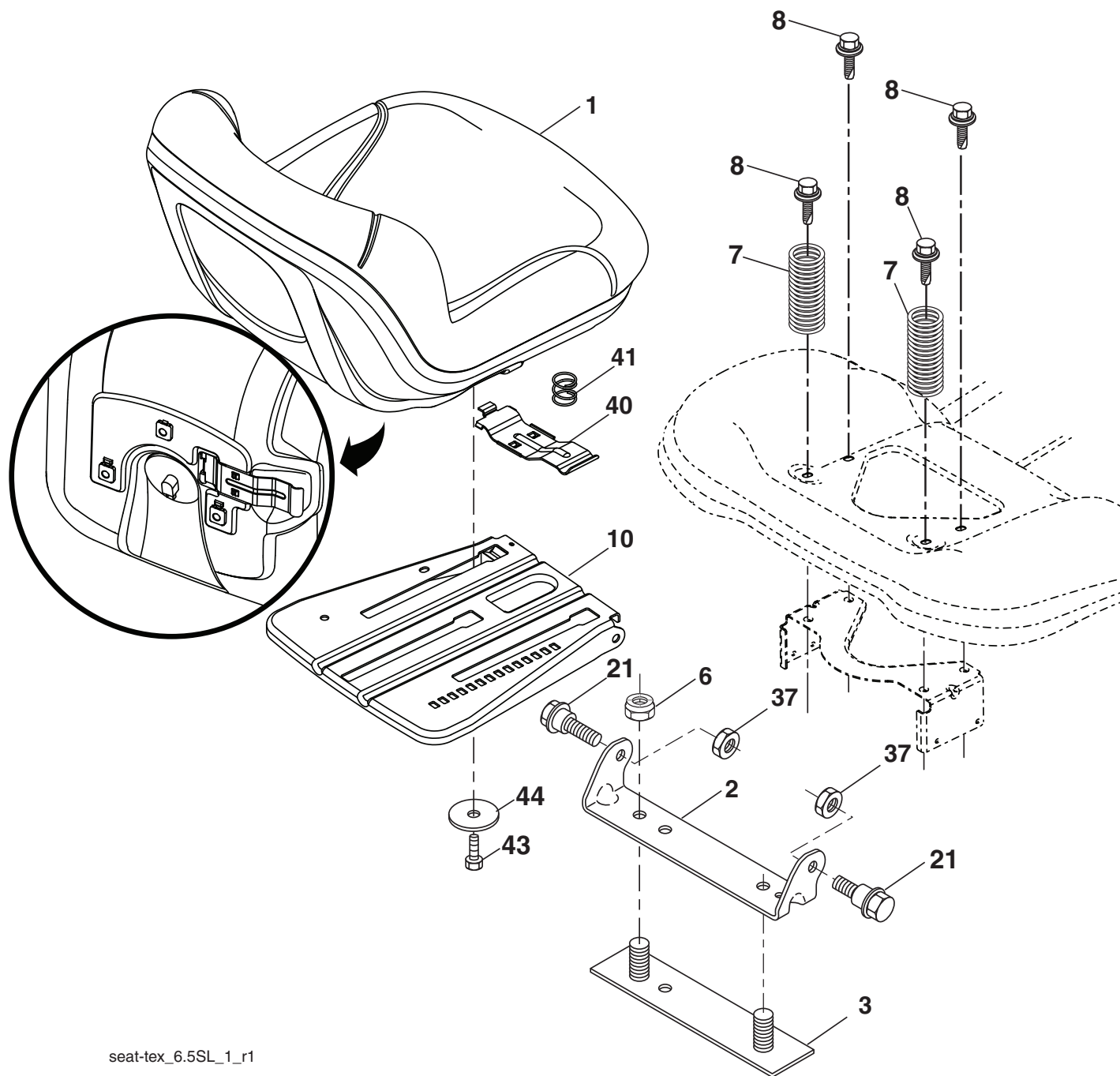

seat-tex_6.5SL_1_r1

KEY NO.	PART NO.	DESCRIPTION
1	532 43 98-22	Seat
2	532 18 01-66	Bracket Pivot Fender
3	532 14 06-75	Strap, Asm Fender
6	873 80 06-00	Nut, Lock w/Ins. 3/8-16 unc
7	532 12 41-81	Spring, Seat Cprsn
8	532 17 18-77	Bolt 5/16-18 unc x 3/4 w/Sems
10	532 19 69-77	Pan, Seat
21	532 17 18-52	Bolt, Shoulder 5/16-18

KEY NO.	PART NO.	DESCRIPTION
37	873 80 05-00	Nut, Lock 5/16-18 unc
40	532 19 76-61	Handle Slide
41	532 19 82-00	Spring Latch
43	874 76 06-12	Bolt 3/8-16 unc x 3/4
44	819 13 38-12	Washer 13/32 x 2-3/8 x 12 Ga.

NOTE: All component dimensions given in U.S. inches
1 inch = 25.4 mm

