

# LT126

**Spare parts**

**Ersatzteile**

**Pièces détachées**

**Reserve onderdelen**

**Repuestos**

**Reservdelar**

# ILLUSTRATED PARTS LIST

**MFG. ID NO. 96041019801**

**CUSTOMER CATALOG NO. LT126**

**PRODUCT NO. 960 41 01-98**

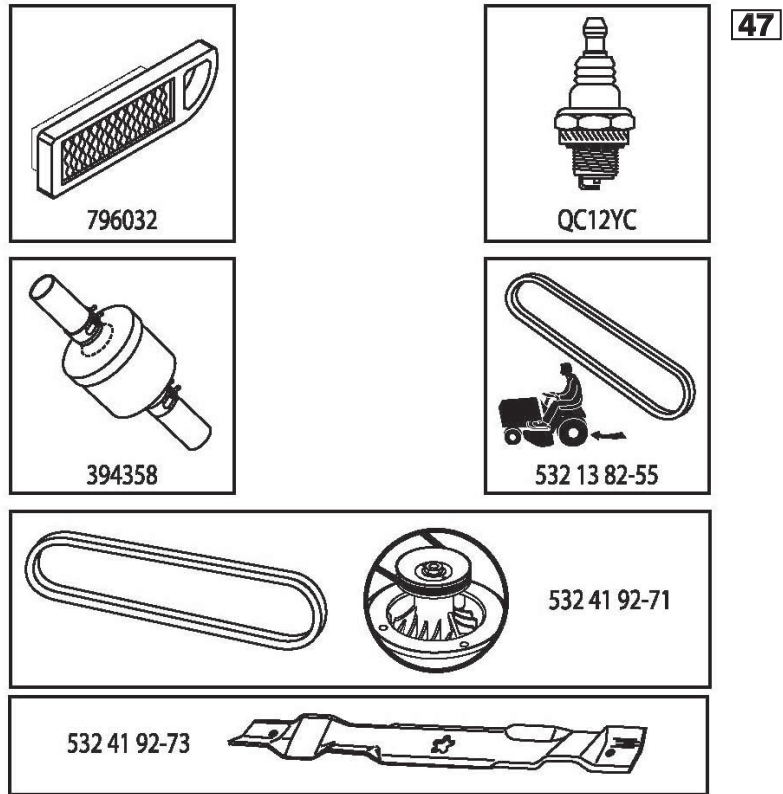

443240

**TRACTOR - - MODEL NO. LT126 (96041019801), PRODUCT NO. 960 41 01-98**  
**DECALS 27**

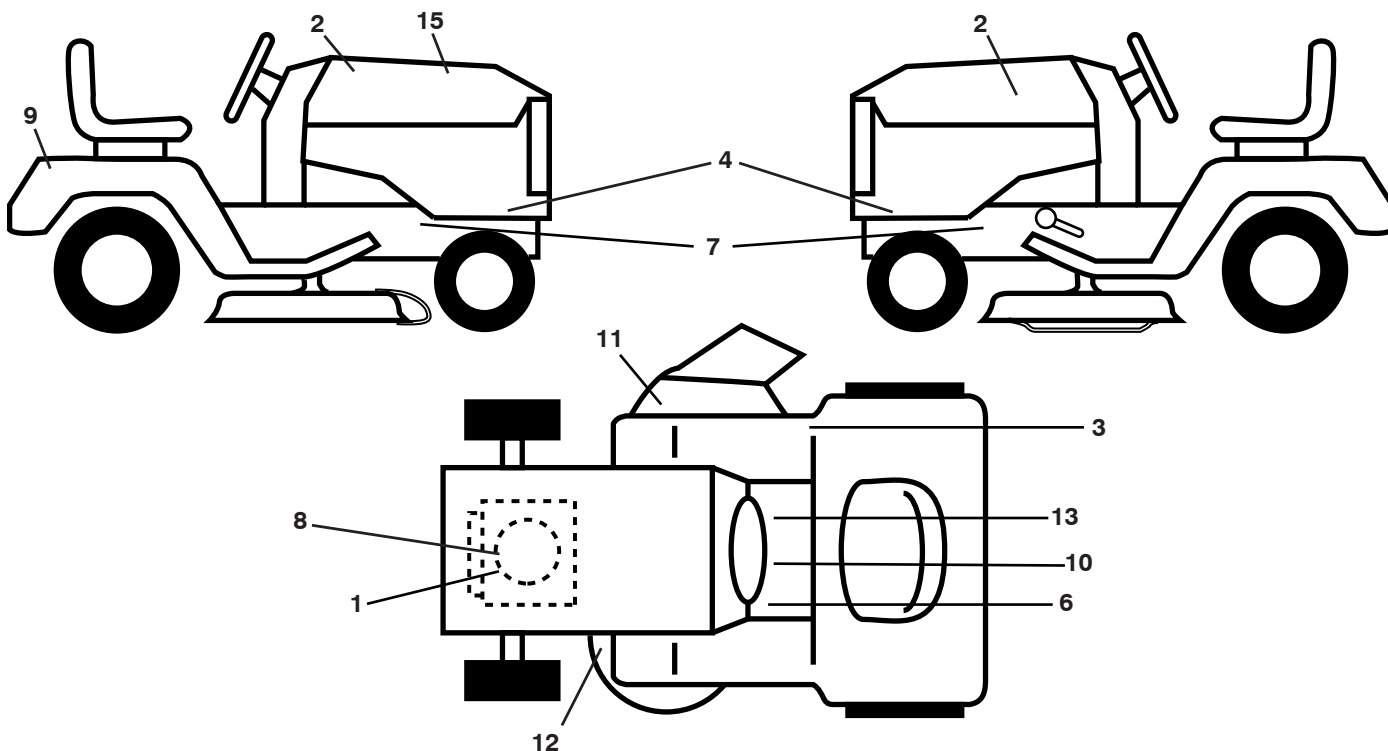

KEY NO.	PART NO.	DESCRIPTION
1	532 19 68-41	Decal, Warning Engine Symbols
2	581 62 73-01	Emblem, Hood
3	532 18 04-32	Decal, Fender 100 DB/CE
4	532 43 78-39	Decal, Side Panel
6	532 15 97-37	Decal, Brake Clutch
7	532 15 97-36	Decal, Chassis Hot Muffler
8	532 43 74-10	Decal, Engine HP
9	532 14 50-05	Decal, Battery Dnge/Poi
10	532 40 03-89	Decal, Warning Symbols
11	532 42 51-12	Decal, Warning Deflector

KEY NO.	PART NO.	DESCRIPTION
12	532 42 15-43	Decal, Mower V-Belt Schematic
13	532 14 08-37	Decal, Saddle Brake Parking
15	532 44 32-40	Decal, Replacement
--	532 16 25-98	Decal, Drawbar Load Limit
--	532 43 96-81	Pad, Footrest, LH
--	532 43 99-66	Pad, Footrest, RH
--	532 43 40-86	Manual, Operator's (Euro)
--	532 43 40-87	Manual, Operator's (Scan)
--	532 43 40-88	Manual, Operator's (Ebloc)
--	532 43 40-89	Manual, Operator's (Baltic)

**WHEELS AND TIRES**

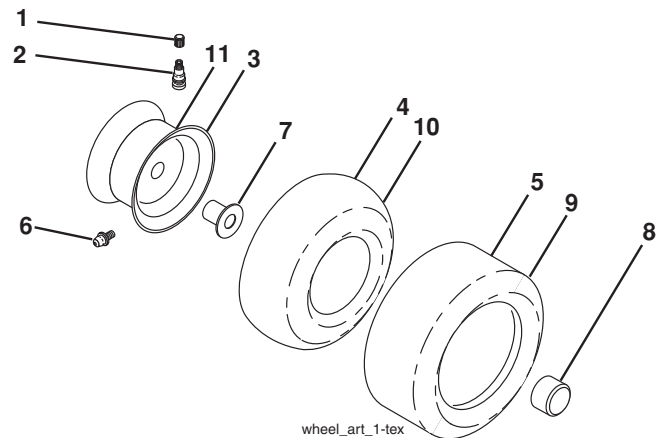

KEY NO.	PART NO.	DESCRIPTION
1	532 05 91-92	Cap Valve Tire
2	532 06 51-39	Stem Valve
3	532 42 52-61	Rim Asm 6" x 3.25 Front
4	532 42 16-52	Tube Front (Service Item Only)
5	532 12 34-10	Tire Front 13 x 5.0-6
6	532 12 49-57	Fitting Grease (Front Wheel Only)
7	532 12 49-59	Bearing Flange (Front Wheel Only)
8	532 17 50-39	Cap Axle Blk 1 50 x 1 00
9	532 10 62-30	Tire Rear 16 x 6 - 5
10	532 00 71-54	Tube Rear (Service Item Only)
11	532 42 52-62	Rim Asm 8" x 5.375 Rear
--	532 14 43-34	Sealant, Tire (10 oz. Tube)

**NOTE:** All component dimensions given in U.S. inches  
 1 inch = 25.4 mm

# TRACTOR - - MODEL NO. LT126 (96041019801), PRODUCT NO. 960 41 01-98

## SCHEMATIC 38

SCH11

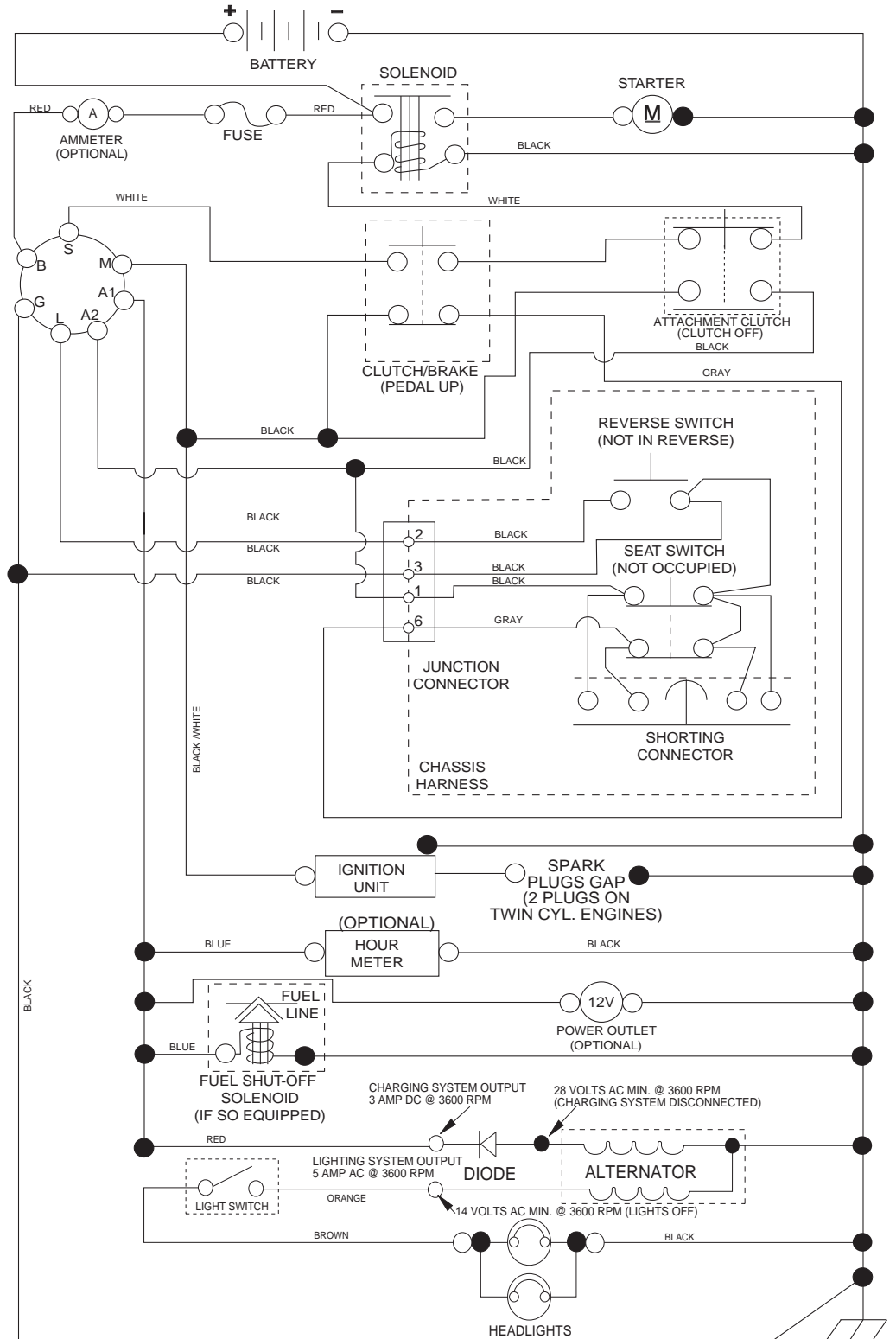

**NOTE**  
 YOUR TRACTOR IS EQUIPPED WITH A SPECIAL ALTERNATOR SYSTEM. THE LIGHTS ARE NOT CONNECTED TO THE BATTERY, BUT HAVE THEIR OWN ELECTRICAL SOURCE. BECAUSE OF THIS, THE BRIGHTNESS OF THE LIGHTS WILL CHANGE WITH ENGINE SPEED. AT IDLE THE LIGHTS WILL DIM. AS THE ENGINE IS SPEEDED UP, THE LIGHTS WILL BECOME THEIR BRIGHTEST.

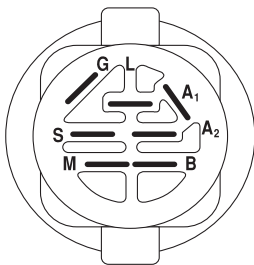

IGNITION SWITCH

POSITION	CIRCUIT	"MAKE"
OFF	M+G+A1	
RUN/OVERRIDE	B+A1	
RUN	B+A1	L+A2
START	B+S+A1	

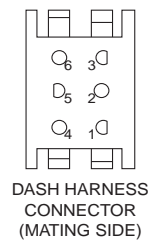
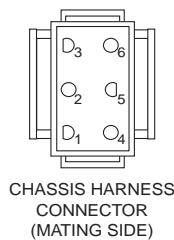

WIRING INSULATED CLIPS  
 NOTE: IF WIRING INSULATED CLIPS WERE REMOVED FOR SERVICING OF UNIT, THEY SHOULD BE RE-INSTALLED TO PROPERLY SECURE YOUR WIRING.

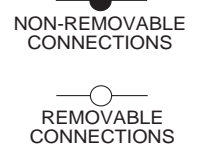

**TRACTOR - - MODEL NO. LT126 (96041019801), PRODUCT NO. 960 41 01-98**  
**ELECTRICAL 32**

T02S

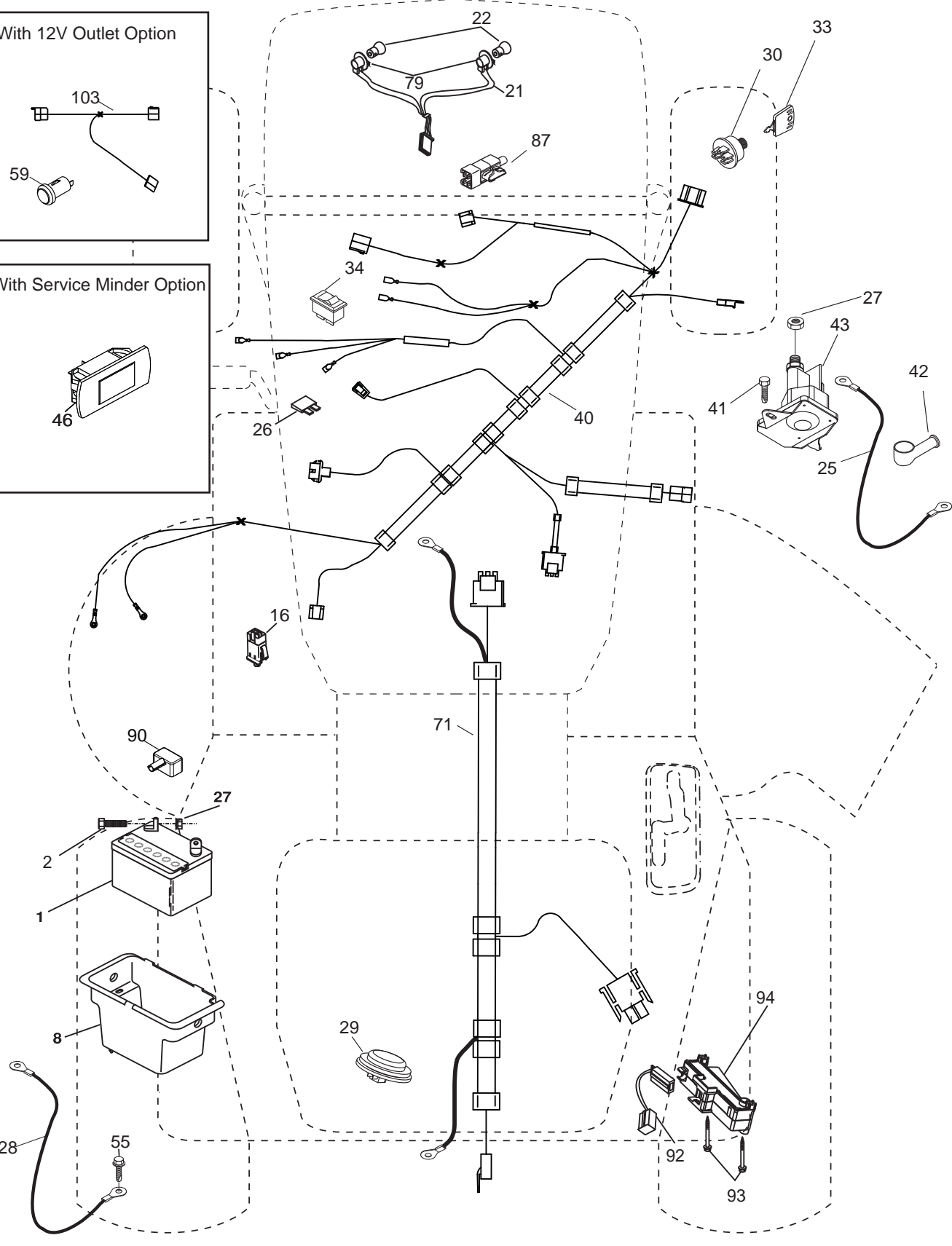
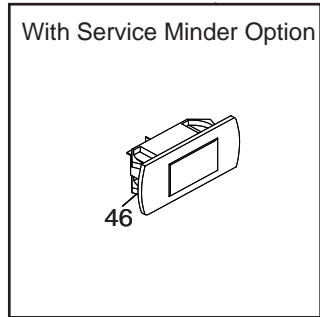
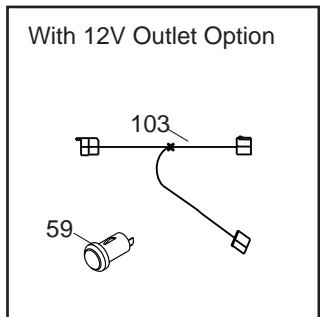

**TRACTOR - - MODEL NO. LT126 (96041019801), PRODUCT NO. 960 41 01-98**  
**ELECTRICAL 32**

<b>KEY NO.</b>	<b>PART NO.</b>	<b>DESCRIPTION</b>
1	532 14 49-24	Battery
2	874 76 04-12	Bolt Hex Head 1/4-20 x 3/4
8	532 19 32-28	Box Battery
16	532 17 61-38	Switch Interlock Push-In
21	532 40 02-52	Harness Socket Light w/4152J
22	532 00 41-52	Bulb Light
25	532 41 28-94	Cable Starter
26	532 17 51-58	Fuse
27	873 51 04-00	Nut Keps Hex 1/4-20 unc
28	532 19 88-85	Cable, Ground
29	532 40 15-45	Switch, Seat
30	532 19 33-50	Switch, Ign
33	532 41 19-35	Key/Chain
34	532 11 07-12	Switch Light/Reset
40	532 40 10-98	Harness Ign. Dash
41	817 72 04-08	Screw Thd Cut 1/4-20 x 1/2
42	532 13 15-63	Cover, Terminal
43	532 19 25-07	Solenoid
55	817 06 05-12	Screw Thdrol 5/16-18 x 3/4
71	532 40 04-49	Harness Chassis
79	532 17 52-42	Socket Asm Bulb Twistlock
87	532 19 78-02	Switch Interlock Clutch Cable
90	532 43 53-95	Cover, Terminal Battery
92	532 19 66-15	Harness Pigtail
93	532 19 25-40	Screw Plastite 10-14-2.0
94	532 19 18-34	Module Reverse

**NOTE:** All component dimensions given in U.S. inches  
1 inch = 25.4 mm

**TRACTOR - - MODEL NO. LT126 (96041019801), PRODUCT NO. 960 41 01-98**  
**CHASSIS AND ENCLOSURES 39**

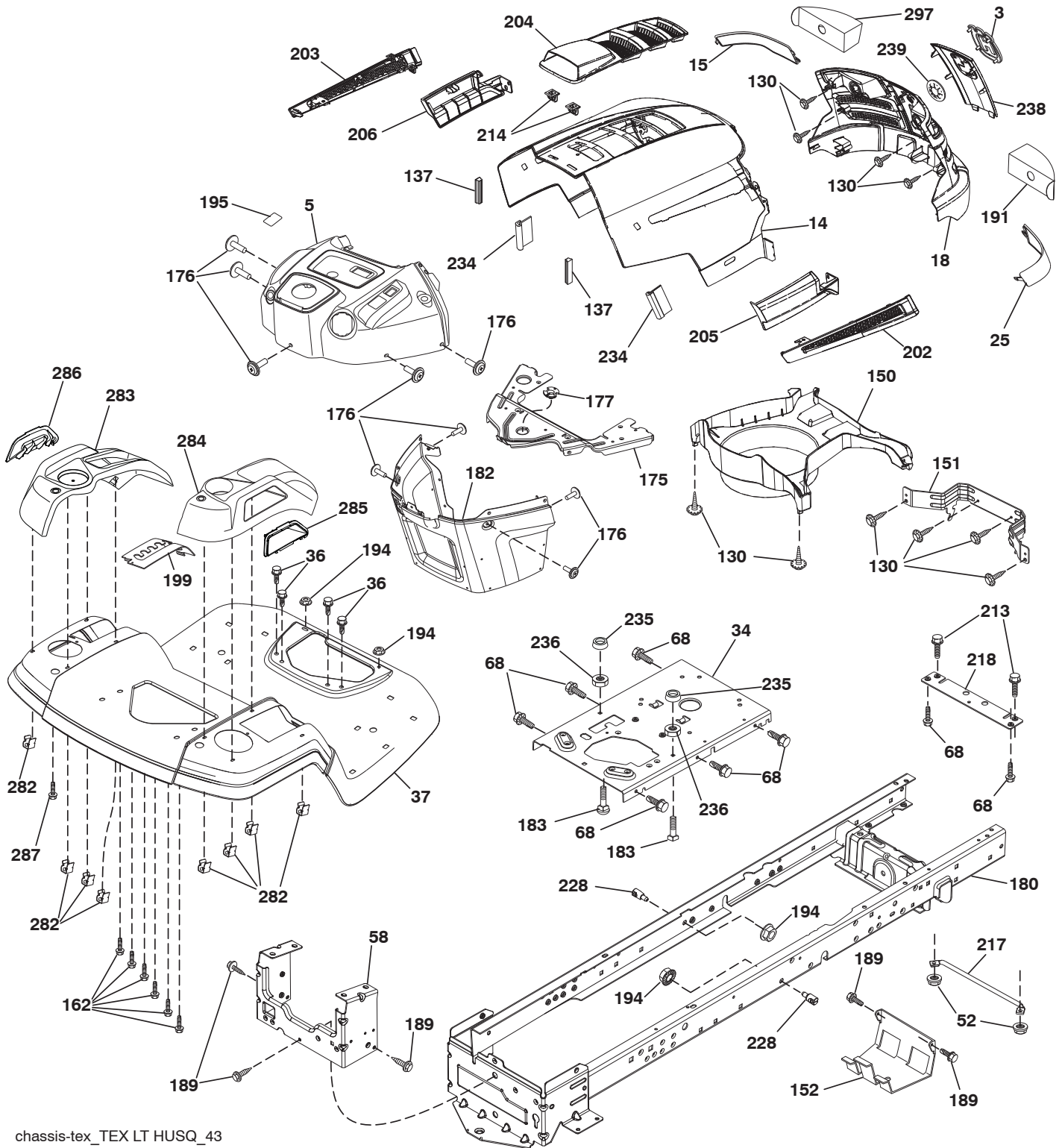

chassis-tex\_TEX LT HUSQ\_43

**TRACTOR - - MODEL NO. LT126 (96041019801), PRODUCT NO. 960 41 01-98  
CHASSIS AND ENCLOSURES 39**

KEY NO.	PART NO.	DESCRIPTION	KEY NO.	PART NO.	DESCRIPTION
3	532 40 50-12	Logo	202	532 44 13-42	Vent Side Hood RH
5	532 43 89-64	Dash	203	532 44 13-43	Vent Side Hood LH
14	532 44 12-67	Hood	204	532 44 13-75	Vent Top Hood
15	532 44 14-28	Lens LH	205	532 44 13-44	Skirt Side RH
18	532 44 13-68	Grille	206	532 44 13-45	Skirt Side LH
25	532 44 14-27	Lens RH	213	874 76 05-12	Bolt 5/16-18 x 3/4
34	532 19 61-25	Plate Engine	214	532 19 91-45	Clip Retainer
36	817 06 05-12	Screw 5/16-18 x 3/4	217	532 40 91-67	Rod Pivot Hood
37	532 44 12-66	Fender	218	532 19 63-95	X-Piece Hood Stop
52	873 68 05-00	Nut Crown Lock 5/16	228	532 19 51-61	Stud Fastener
58	532 41 22-80	Drawbar, Upper	234	532 40 47-42	Bumper Hood
68	817 49 05-08	Screw THDROL 5/16-18 x 1/2	235	532 40 61-29	Spacer Fender
130	532 41 63-58	Screw #10 x .750 BOS Thread	236	873 93 05-00	Nut Lock 5/16-18 unc
137	532 40 75-90	Bumper Dash	238	532 44 13-74	Trim
150	532 40 66-62	Air Duct	239	532 40 48-83	Clip Tinnerman
151	532 40 78-07	Bracket Pivot	282	532 41 41-10	Clip Retainer Console
152	532 19 95-35	Shield Browning	283	532 44 20-39	Console Deck Lift
162	532 14 24-32	Screw	284	532 44 33-30	Console Shift
175	532 19 94-72	Crossmember	285	532 41 63-15	Console Insert RH
176	532 40 07-76	Screw 10-24 x 5/8	286	532 41 63-17	Console Insert LH
177	532 19 52-28	Bushing Steering	287	817 60 04-06	Screw Hex Washhead 1/4-20 x 3/8
180	532 41 46-85	Chassis	297	532 40 66-65	Insert Reflective LH
182	532 40 71-76	Dash Lower			
183	874 52 05-20	Bolt 5/16-18 x 1-1/4			
189	817 00 05-12	Screw 5/16-18 x 3/4			
191	532 41 65-01	Insert Reflective RH			
194	873 90 05-00	Nut Lock Hex Flange 5/16-18			
195	532 43 99-76	Plug Dash			
199	532 41 34-85	Plate Deck Lift			

**NOTE:** All component dimensions given in U.S. inches  
1 inch = 25.4 mm



TRACTOR - - MODEL NO. LT126 (96041019801), PRODUCT NO. 960 41 01-98  
DRIVE **40**

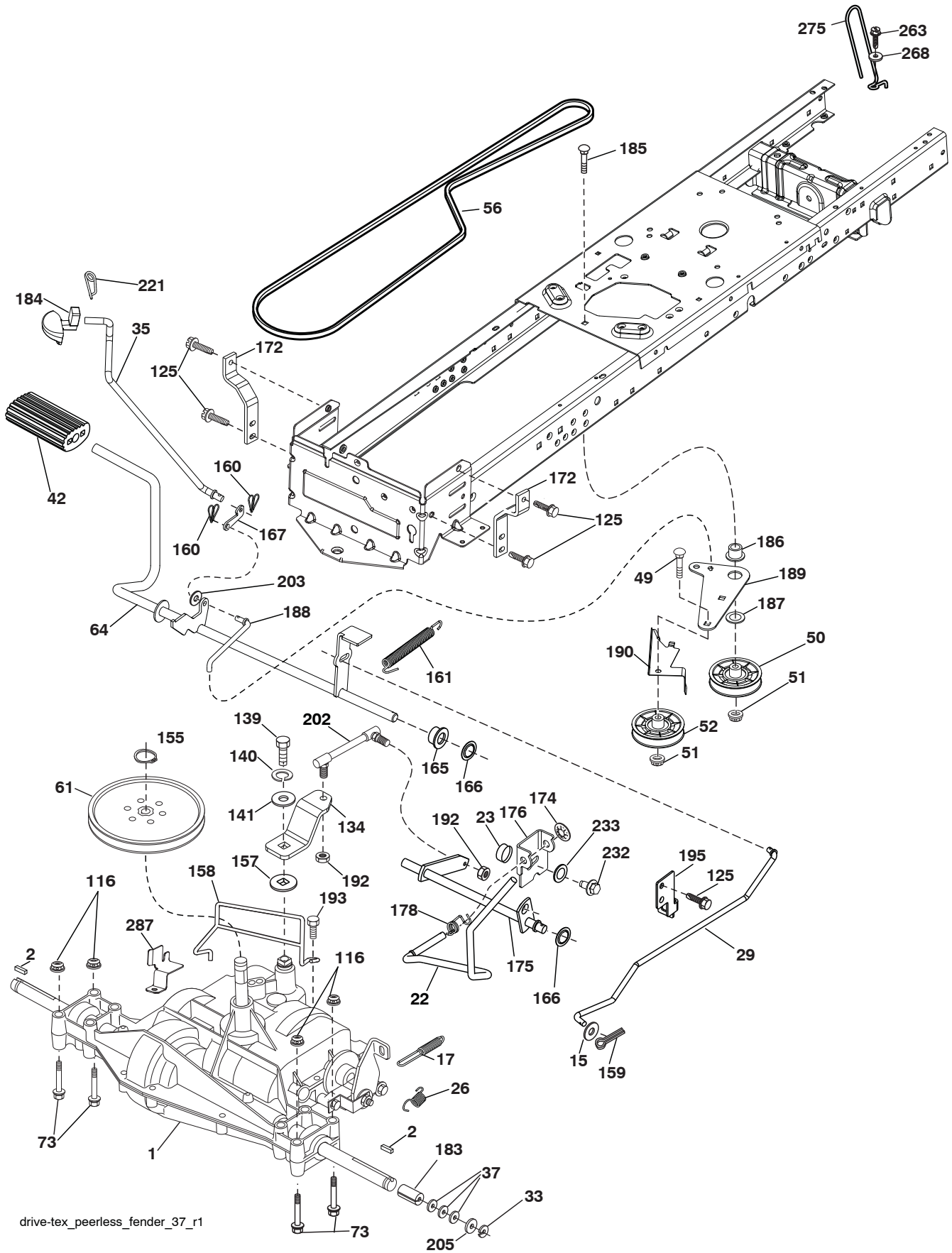

drive-tex\_peerless\_fender\_37\_r1

**TRACTOR - - MODEL NO. LT126 (96041019801), PRODUCT NO. 960 41 01-98**  
**DRIVE 40**

KEY NO.	PART NO.	DESCRIPTION	KEY NO.	PART NO.	DESCRIPTION
1	---	Transaxle, Peerless 206-565 (197941) (Order parts from trans-axle manufacturer)	166	532 42 91-64	Nut Push .625
2	532 12 35-83	Key Square	167	532 40 52-57	Latch Brake Parking
15	819 13 13-16	Washer 13/32 x 13/16 x 16 Ga.	172	532 19 76-57	Strap Torque LH
17	532 19 72-97	Spring, Brake	174	532 19 72-89	Nut Push
22	532 19 76-60	Rod Shift	175	532 19 78-58	Shaft Asm Shift
23	532 12 12-74	Knob	176	532 19 62-14	Arm Clevis Rod Shift
26	532 19 74-55	Spring Brake RTN	178	532 19 74-56	Spring Shift
29	532 19 72-67	Rod, Brake	183	532 13 70-57	Spacer, Axle
33	812 00 00-01	Ring E	184	532 44 14-07	Handle Parking Brake
35	532 40 10-31	Rod, Brake, Park	185	872 11 06-22	Bolt 3/8-16 unc x 2-3/4 Gr 5
37	532 12 17-49	Washer 25/32 x 1-1/4 x 16 Ga.	186	532 19 43-21	Spacer Retainer
42	532 12 48-72	Cover, Foot Pedal	187	819 13 32-10	Washer
49	872 11 06-14	Bolt 3/8-16 unc x 1-3/4 Gr 5	188	532 19 43-23	Link Clutch Ground Drive
50	532 19 43-27	Pulley Idler Flat	189	532 19 43-17	Bellcrank Ground Drive
51	873 90 06-00	Lock Nut 3/8-16	190	532 19 43-18	Keeper Bellcrank Ground Drive
52	532 19 43-26	Idler V-Groove	192	532 15 03-60	Nut Lock Center 1/4-28
56	532 13 82-55	V-Belt, Drive	193	817 06 05-12	Screw 5/16-18 x 3/4
61	532 16 59-99	Pulley Transaxle	195	532 19 73-32	Bracket Brake Rod
64	532 19 62-00	Shaft Asm. Pedal Brake Control	202	532 19 78-59	Link Shift
73	874 49 05-44	Bolt 5/16-18 Gr. 5	203	819 11 11-16	Washer 11/32 x 11/16 x 16 Ga.
116	873 90 05-00	Nut Lock Hex Flange 5/16-18	205	532 12 17-48	Washer 25/32 x 1-5/8 x 16 Ga.
125	817 00 05-12	Screw 5/16-18 x 3/4	221	532 40 31-87	Retainer Spring Clip Handle
134	532 19 78-57	Arm Shift	232	874 78 07-16	Bolt 7/16-14 x 1 Gr. 5
139	874 55 04-12	Bolt 1/4-20 unf Gr. 8 w/Patch	233	532 40 52-96	Washer Serrated
140	810 04 04-00	Washer Lock Hvy Helical 1/4	263	817 00 06-12	Screw Hexwsh Thd 3/8-16 x 3/4
141	819 09 12-10	Washer 9/32 x 3/4 x 10 Ga.	268	819 13 16-14	Washer 13/32 x 1 x 14 Ga.
155	812 00 00-28	Ring Retainer	275	532 18 24-02	Guard Muffler
157	532 10 57-01	Washer Plate Shf	287	532 42 16-48	Keeper Pulley Transaxle
158	532 19 43-52	Keeper T/A			
159	876 02 04-12	Pin Cotter 1/8 x 3/4			
160	532 16 94-84	Retainer Clip			
161	532 10 57-09	Spring, Return, Clutch			
165	532 19 62-12	Busing Shaft Brake Hand Control			

**NOTE:** All component dimensions given in U.S. inches  
1 inch = 25.4 mm

TRACTOR - - MODEL NO. LT126 (96041019801), PRODUCT NO. 960 41 01-98  
ENGINE **24**

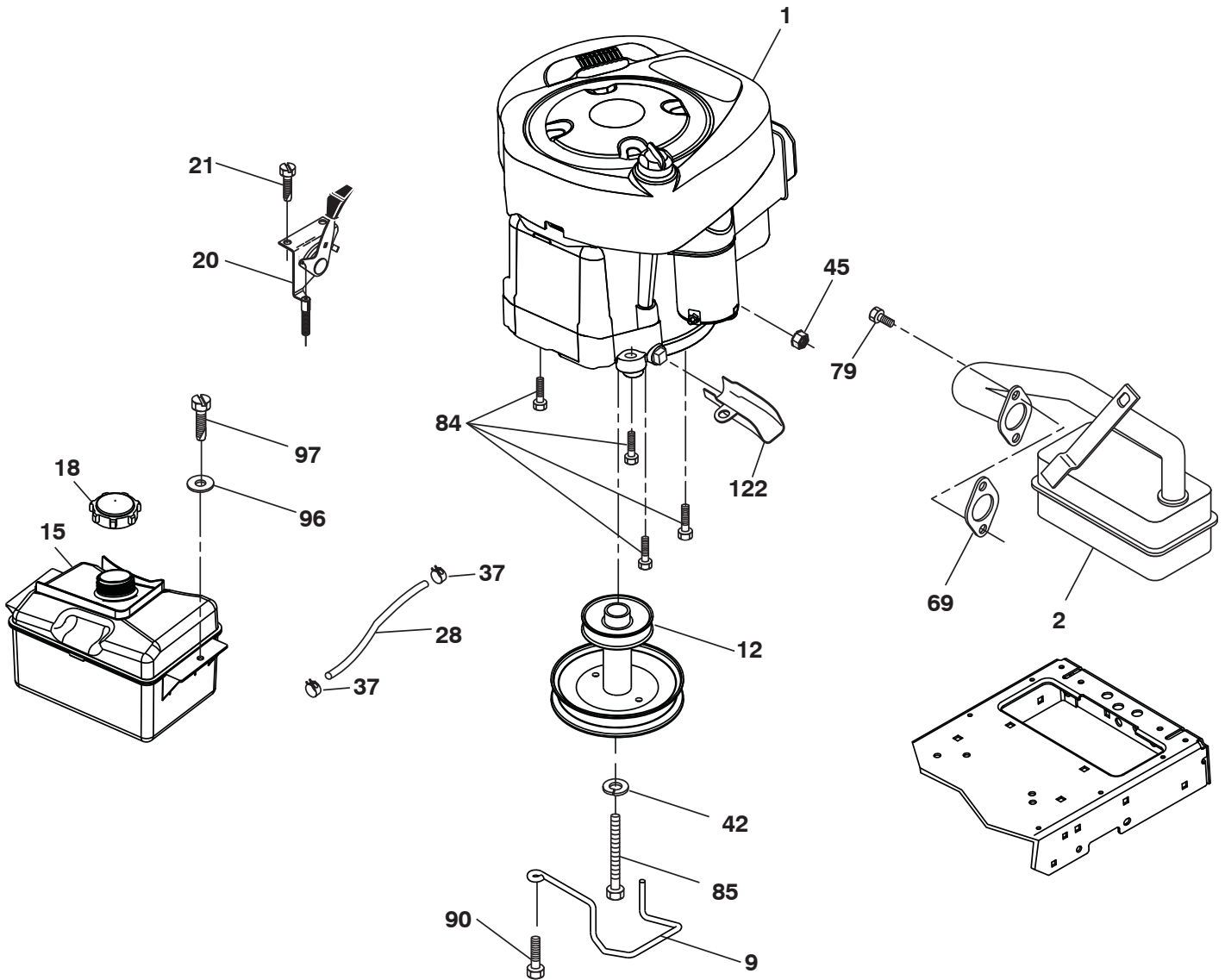

29

**OPTIONAL EQUIPMENT**  
**Spark Arrester**

engine-tex\_BS\_34

**TRACTOR - - MODEL NO. LT126 (96041019801), PRODUCT NO. 960 41 01-98  
ENGINE 24**

KEY NO.	PART NO.	DESCRIPTION
1	- - - - -	Engine Briggs Model No. 219807-3210-B1 (438615) (Order parts from engine manufacturer)
2	532 17 97-58	Muffler
9	532 19 43-19	Keeper Belt Engine
12	532 14 01-86	Pulley Engine
15	532 40 75-45	Tank Fuel
18	532 43 02-20	Cap Fuel
20	532 18 38-97	Control Throttle
21	532 41 63-58	Screw #10 x 0.750 BOS Thread
28	532 13 70-40	Fuel Line
29	532 13 71-80	Spark Arrester Kit
37	532 12 34-87	Clamp Hose
42	810 04 07-00	Washer Lock 7/16
45	873 51 04-00	Nut Keps Hex 1/4-20 unc
69	532 16 52-91	Gasket
79	532 19 23-34	Screw 5/16-18 x 3/4
84	817 06 06-20	Screw 3/8-16 x 1/4
85	532 17 39-37	Bolt Hex 7/16-20 x 4 Gr. 5
90	817 00 06-16	Screw 3/8-16 x 1
96	819 09 14-16	Washer 9/32 x 7/8 x 16 Ga.
97	817 67 04-12	Screw 1/4-20 x 3/4
122	532 42 19-22	Extension Oil Drain

**NOTE:** All component dimensions given in U.S. inches  
1 inch = 25.4 mm

**Engine Power Rating Information**

The gross power rating for individual gas engine models is labeled in accordance with SAE (Society of Automotive Engineers) code J1940 (Small Engine Power & Torque Rating Procedure), and rating performance has been obtained and corrected in accordance with SAE J1995 (Revision 2002-05). Torque values are derived at 3060 RPM; horsepower values are derived at 3600 RPM. Actual gross engine power will be lower and is affected by, among other things, ambient operating conditions and engine-to-engine variability. Given both the wide array of products on which engines are placed and the variety of environmental issues applicable to operating the equipment, the gas engine will not develop the rated gross power when used in a given piece of power equipment (actual "on-site" or net power). This difference is due to a variety of factors including, but not limited to, accessories (air cleaner, exhaust, charging, cooling, carburetor, fuel pump, etc.), application limitations, ambient operating conditions (temperature, humidity, altitude), and engine-to-engine variability. Due to manufacturing and capacity limitations, Briggs & Stratton may substitute an engine of higher rated power for this Series engine.

TRACTOR - - MODEL NO. LT126 (96041019801), PRODUCT NO. 960 41 01-98  
STEERING ASSEMBLY **41**

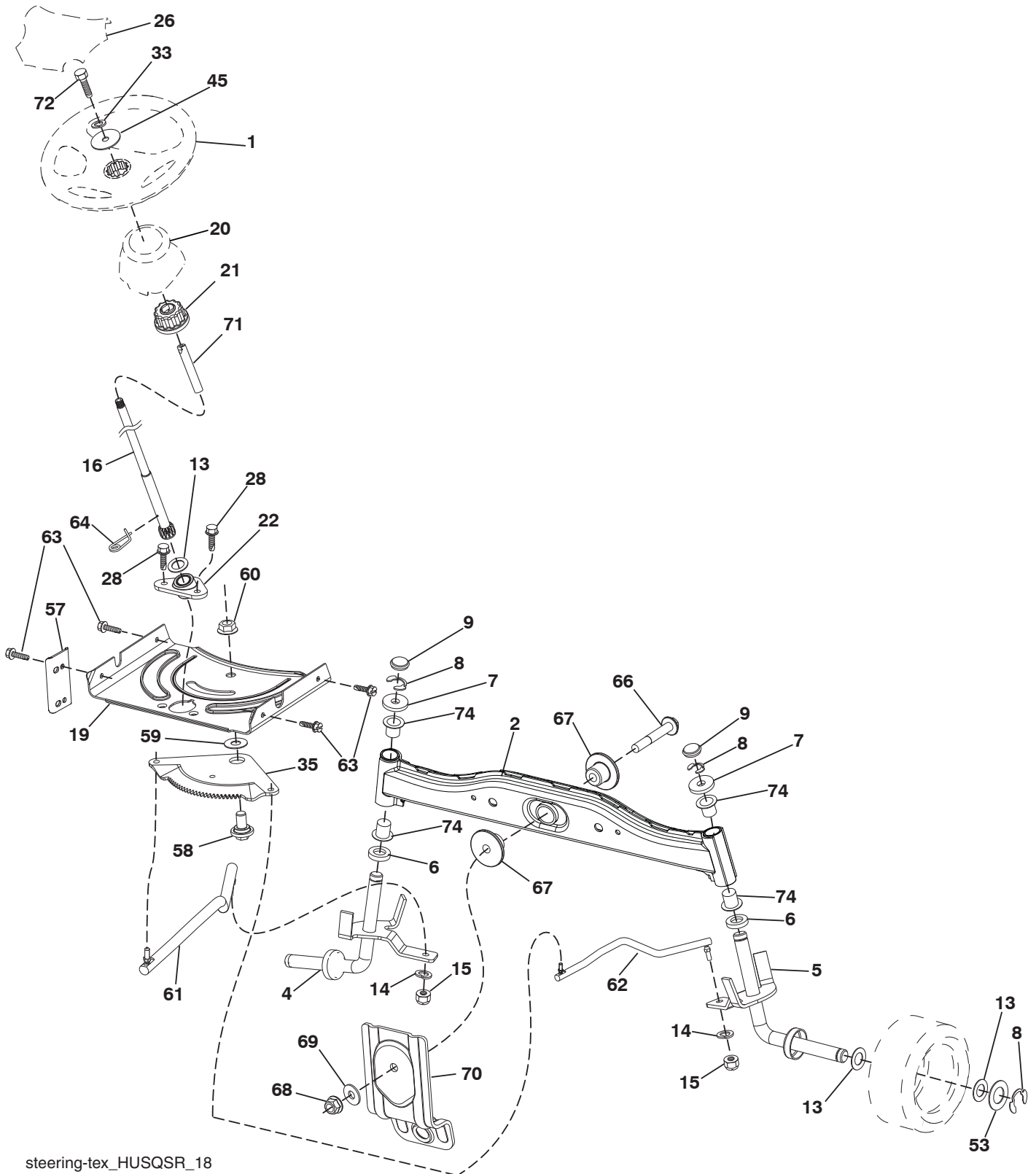

steering-tex\_HUSQSR\_18

**TRACTOR - - MODEL NO. LT126 (96041019801), PRODUCT NO. 960 41 01-98**  
**STEERING ASSEMBLY 41**

<b>KEY NO.</b>	<b>PART NO.</b>	<b>DESCRIPTION</b>
1	532 43 97-40	Wheel, Steering
2	532 41 81-68	Axle Asm., Front
4	532 41 68-45	Spindle Asm., LH
5	532 41 68-46	Spindle Asm., RH
6	532 12 49-31	Washer Thrust
7	532 12 17-48	Washer 25/32 x 1-5/8 x 16 Ga.
8	812 00 00-29	Ring, Klip #T5304-75
9	532 12 12-32	Cap, Spindle
13	532 12 17-49	Washer 25/32 x 1-1/4 x 16 Ga.
14	810 04 06-00	Washer, Lock Hvy Hlcl Spr 3/8
15	873 54 06-00	Nut, Crown Lock 3/8-24 unf
16	532 42 93-73	Shaft Steering
19	532 19 47-29	Plate Steering
20	532 44 14-25	Boot, Steering
21	532 18 67-37	Adapter, Wheel Steering
22	532 42 05-37	Strg. Supt. Lower
26	532 43 97-43	Insert, Wheel Steering
28	817 00 06-12	Screw 3/8-16 x 3/4
33	810 04 05-00	Washer Lock 5/16
35	532 19 47-32	Gear, Sector Plate
45	819 11 38-12	Washer 11/32 x 3/8 x 12 Ga.
53	532 18 89-67	Washer Hardened .793 x 1.637 x .060
57	532 40 74-65	Bracket Upstop
58	532 19 47-47	Bolt Shoulder Sector Pivot CFM
59	532 19 47-48	Washer Thrust Sector Steering
60	873 97 10-00	Nut Flange Lock 5/8-11
61	532 19 47-40	Draglink, LH
62	532 19 47-41	Draglink, RH
63	817 00 05-12	Screw 5/16-18 x 3/4
64	532 19 98-49	Retainer Clip Spring Steering
66	871 02 07-48	Bolt Hex Fghd 7/16-14 x 3 Serr
67	532 19 47-37	Bushing PM Front Axle
68	873 90 07-00	Nut Lock Flange 7/16-14 Gr. 5
69	532 19 91-62	Washer 1.5 x .505 x .118
70	532 41 70-65	Bracket Deck Susp. Front
71	532 19 07-52	Shaft Extension Steering
72	532 42 89-82	Bolt Fin Hx 5/16-18 x 4
74	532 12 49-37	Bearing

**NOTE:** All component dimensions given in U.S. inches  
1 inch = 25.4 mm

TRACTOR - - MODEL NO. LT126 (96041019801), PRODUCT NO. 960 41 01-98  
MOWER DECK 44

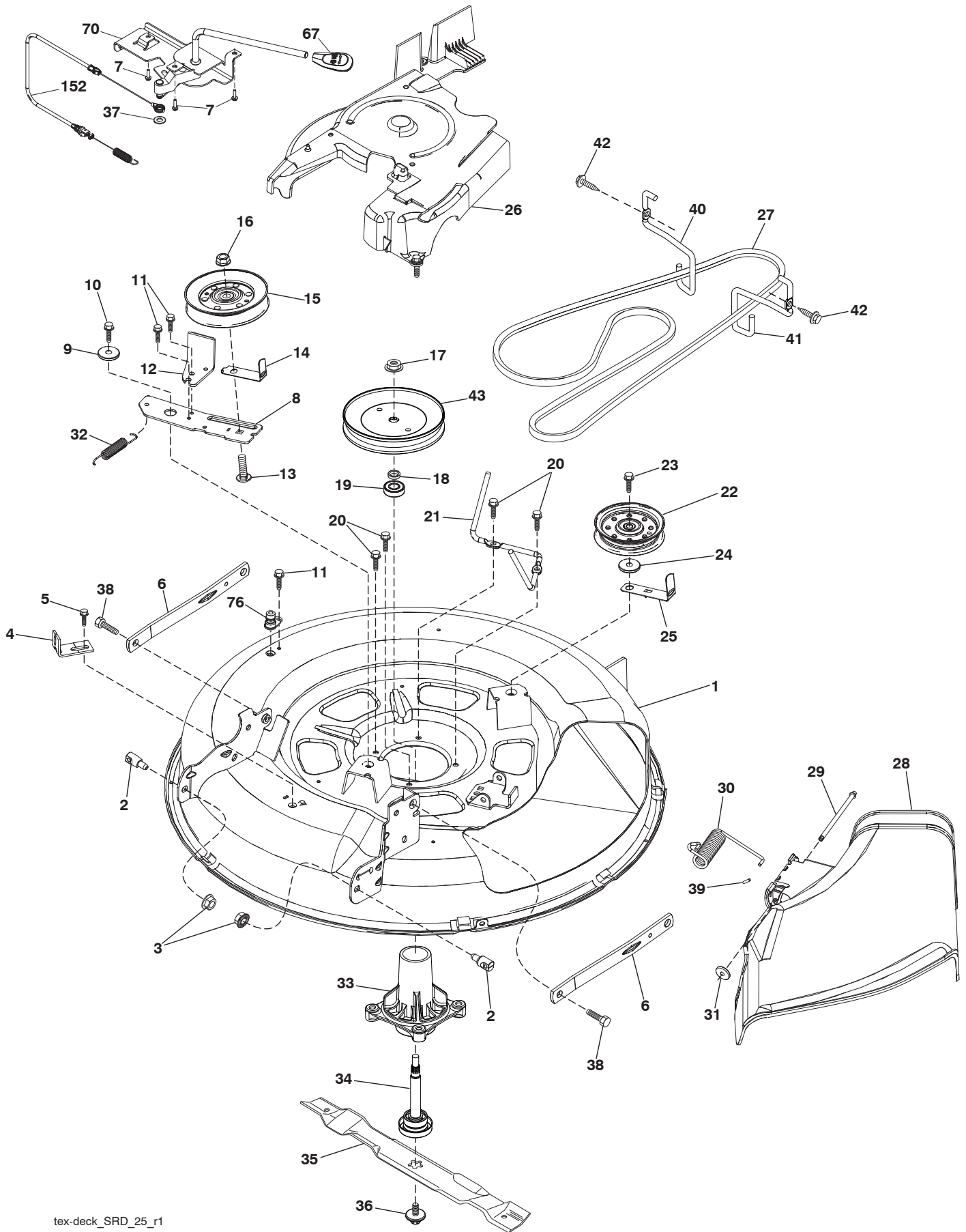

**TRACTOR - - MODEL NO. LT126 (96041019801), PRODUCT NO. 960 41 01-98  
MOWER DECK 44**

KEY NO.	PART NO.	DESCRIPTION	KEY NO.	PART NO.	DESCRIPTION
1	532 44 20-48	Deck Weldment 30"Srd	30	532 19 70-26	Spring Torsion Dfl 38/42/46 Gr
2	532 19 51-61	Stud Fastner W/D'anti-Rotatio	31	532 11 04-52	Nut Push Phos & Oil
3	873 90 05-00	Nut Lock Hex Flange 5/16 - 18	32	532 40 18-72	Spring Return Deck 38/46"
4	532 41 76-45	Bracket Clutch Cable	33	532 18 72-81	Housing Mandrel 4pt Service
5	817 00 05-10	Bolt 5/16-18	34	532 19 28-72	Shaft Asm Mndrl N/Greaseable38
6	532 41 88-63	Arm Susp Mower Rear Srd	35	532 41 92-73	Blade Mower Hp/Mulch Srd
7	532 41 63-58	Screw #10 x 0.750 BOS Thread	36	532 19 30-03	Bolt/Washer Asm 7/16 - 20 unf
8	532 42 02-52	Arm Idler 30"Srd	37	819 13 13-16	Washer 13/32 x 13/16 x 16 Ga.
9	532 19 90-92	Spacer Retainer	38	532 19 65-39	Bolt Shoulder
10	817 00 06-16	Screw 3/8 - 16 X 1 Smgml Tap/R Blk	39	532 10 53-04	Cap Sleeve
11	532 13 77-29	Screw Thd Roll 1/4 - 20 X 5/8	40	532 41 92-70	Keeper Belt Engine LH
12	532 19 94-70	Arm Brake Mower 38" RH Tex	41	532 41 92-65	Keeper Belt Engine RH
13	872 11 06-12	Bolt Carr Sh 3/8 - 16 X 1 - 1/2 Gr5	42	817 00 06-12	Screw Hexwsh THDR 3/8-16x3/4 BL
14	532 15 60-85	Keeper Belt Idler	43	532 41 68-77	Pulley Mandrel 6 5 Pd 30"
15	532 14 67-63	Pulley Ikler V-Groove Dim 4.25	67	532 40 30-12	Handle clutch cable
16	873 90 06-00	Nut Lock FIG 3/8 - 16 unc	70	532 40 12-46	Clutch Asm. Manual
17	532 40 02-34	Nut Flange Lock Top	76	532 41 55-98	Washout Port
18	532 18 76-90	Washer Spacer Mandrel	152	532 43 51-11	Manual Clutch Cable
19	532 11 04-85	Bearing Ball Mandrel	--	532 19 28-70	Mandrel Assembly (Includes Hous- ing, Shaft Assembly, And Bearing Only - Pulley/Nut/Washer And Blade Bolt/Washers Not Included)
20	532 17 39-84	Screw Thd Roll Dod Pt Hex	--	532 43 44-89	Replacement Mower Complete
21	532 41 69-10	Keeper Belt Mandrel 30"			
22	532 17 58-20	Pulley Idler Flat			
23	817 49 06-28	Screw Thdrol 3/8 - 16 X 1-3/4			
24	819 13 20-12	Washer 13/32 X 1 - 1/4 X 12 Ga			
25	532 42 02-53	Keeper Belt 30"Srd			
26	532 43 03-13	Cover Mandrel Mwr 30"Black			
27	532 41 92-71	V-Belt Drive			
28	532 41 73-44	Shield Asm Deflect Mwr 30s Blk			
29	532 42 08-95	Pin Hinge 30			

**NOTE:** All component dimensions given in U.S. inches  
1 inch = 25.4 mm



**TRACTOR - - MODEL NO. LT126 (96041019801), PRODUCT NO. 960 41 01-98**  
**SEAT ASSEMBLY 42**

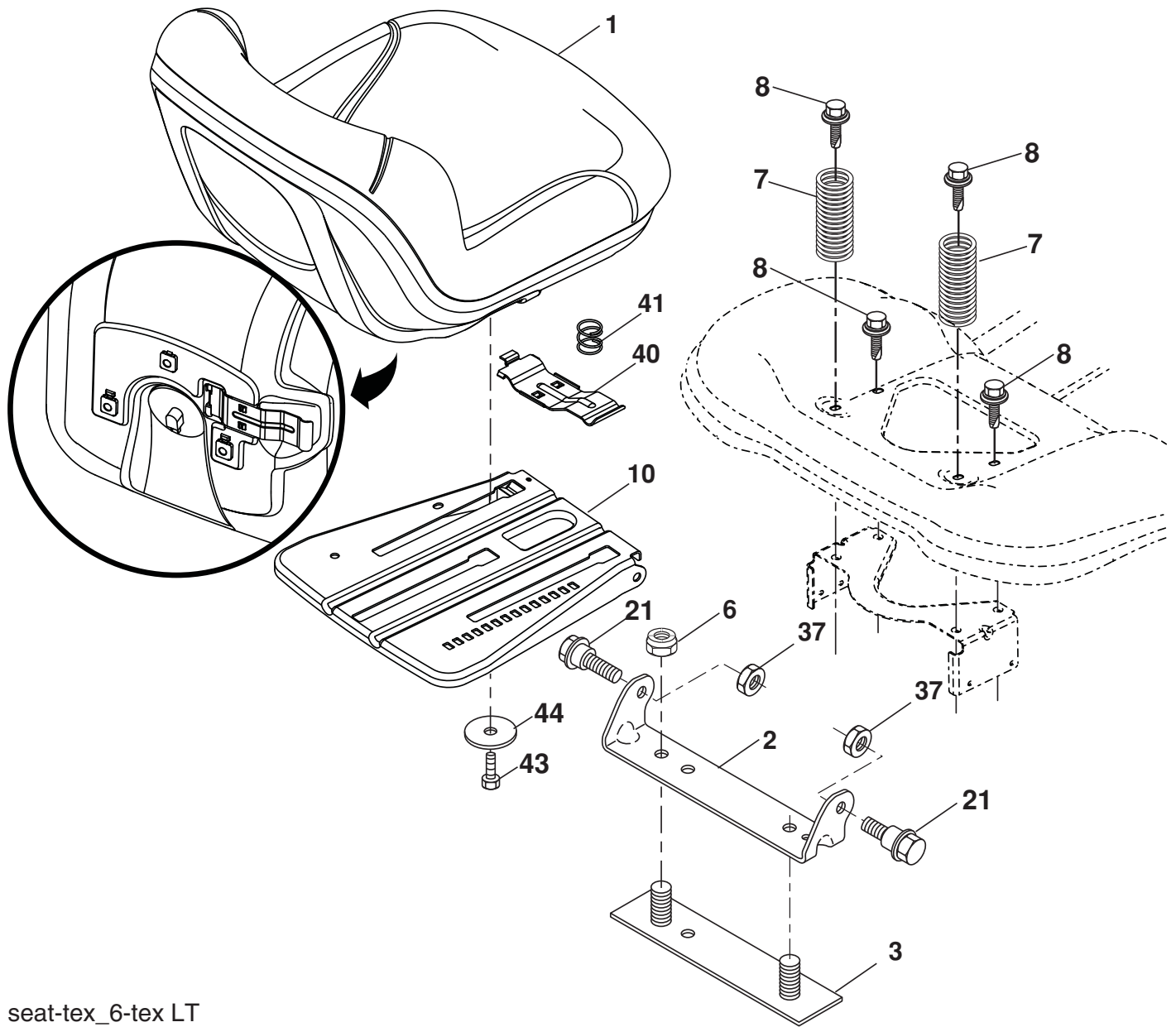

seat-tex\_6-tex LT

KEY NO.	PART NO.	DESCRIPTION
1	532 43 98-19	Seat
2	532 18 01-66	Bracket Pivot Fender
3	532 14 06-75	Strap, Asm Fender
6	873 80 06-00	Nut, Lock w/Ins. 3/8-16 unc
7	532 12 41-81	Spring, Seat Cprsn
8	532 17 18-77	Bolt 5/16-18 unc x 3/4 w/Sems
10	532 19 69-77	Pan, Seat
21	532 17 18-52	Bolt, Shoulder 5/16-18

KEY NO.	PART NO.	DESCRIPTION
37	873 80 05-00	Nut, Lock 5/16-18 unc
40	532 19 76-61	Handle Slide Seat
41	532 19 82-00	Spring Latch Seat
43	874 76 06-12	Bolt Fin Hex 3/8-16 unc x 3/4
44	819 13 38-12	Washer 13/32 x 2-3/8 x 12 Ga.

**NOTE:** All component dimensions given in U.S. inches  
 1 inch = 25.4 mm

**TRACTOR - - MODEL NO. LT126 (96041019801), PRODUCT NO. 960 41 01-98**  
**MOWER LIFT 45**

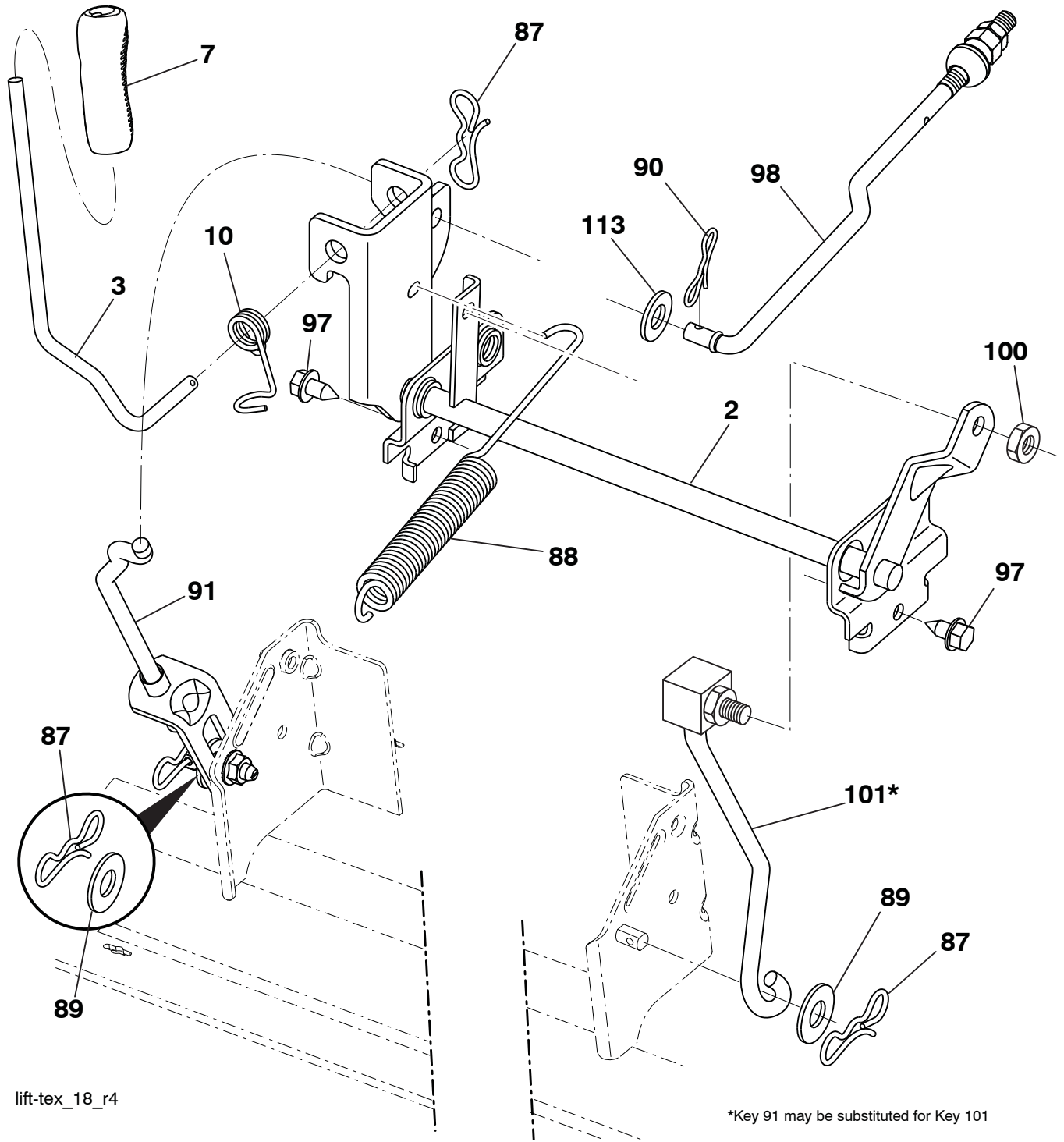

lift-tex\_18\_r4

\*Key 91 may be substituted for Key 101

KEY NO.	PART NO.	DESCRIPTION
2	532 42 20-27	Shaft Asm., Lift
3	532 19 52-31	Lever Asm., Lift RH
7	532 41 15-55	Grip, Lever
10	532 19 63-14	Spring Torsion
87	532 19 42-09	Pin Cotter 7/16 Bow Tie Lock
88	532 41 07-10	Spring Lift Assist
89	819 19 19-12	Washer Clear Zinc
90	532 19 42-08	Pin Cotter 5/16 Bow Tie Lock
91	532 19 51-81	Link Asm Lift LH Rear

KEY NO.	PART NO.	DESCRIPTION
97	817 00 06-12	Screw Hex Wsh. THDR 3/8-16 x 3/4
98	532 19 52-64	Link Lift Susp. Front Mower
100	873 93 06-00	Nut Centerlock 3/8-16 unc
101	532 40 70-03	Link Asm Lift FXD
113	819 17 19-12	Washer 17/32 x 1 - 3/16 x 12 Ga.

**NOTE:** All component dimensions given in U.S. inches  
 1 inch = 25.4 mm

