

ILLUSTRATED PARTS LIST

MODEL NO. 96041020101

CUSTOMER CATALOG NO. LTH151

PRODUCT NO. 960 41 02-01

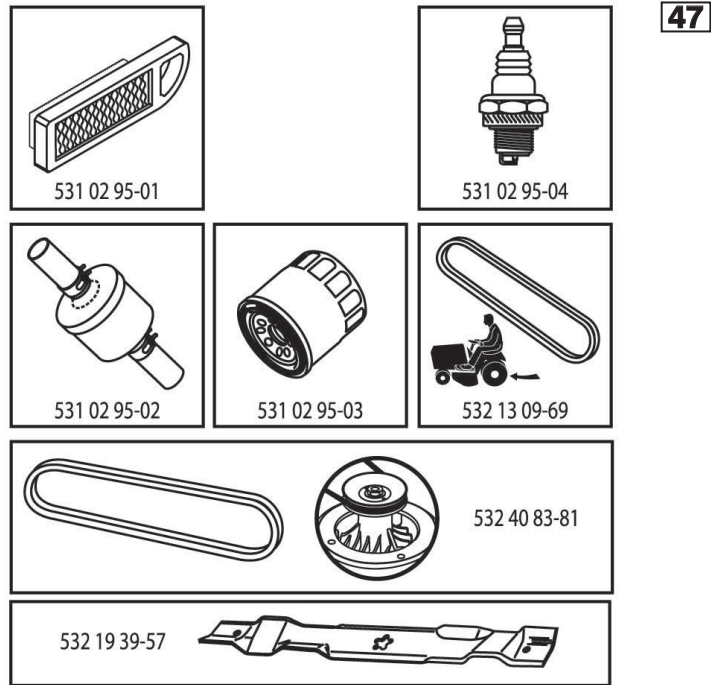

437776

**TRACTOR - - MODEL NO. LTH151 (96041020101), PRODUCT NO. 960 41 02-01
DECALS 27**

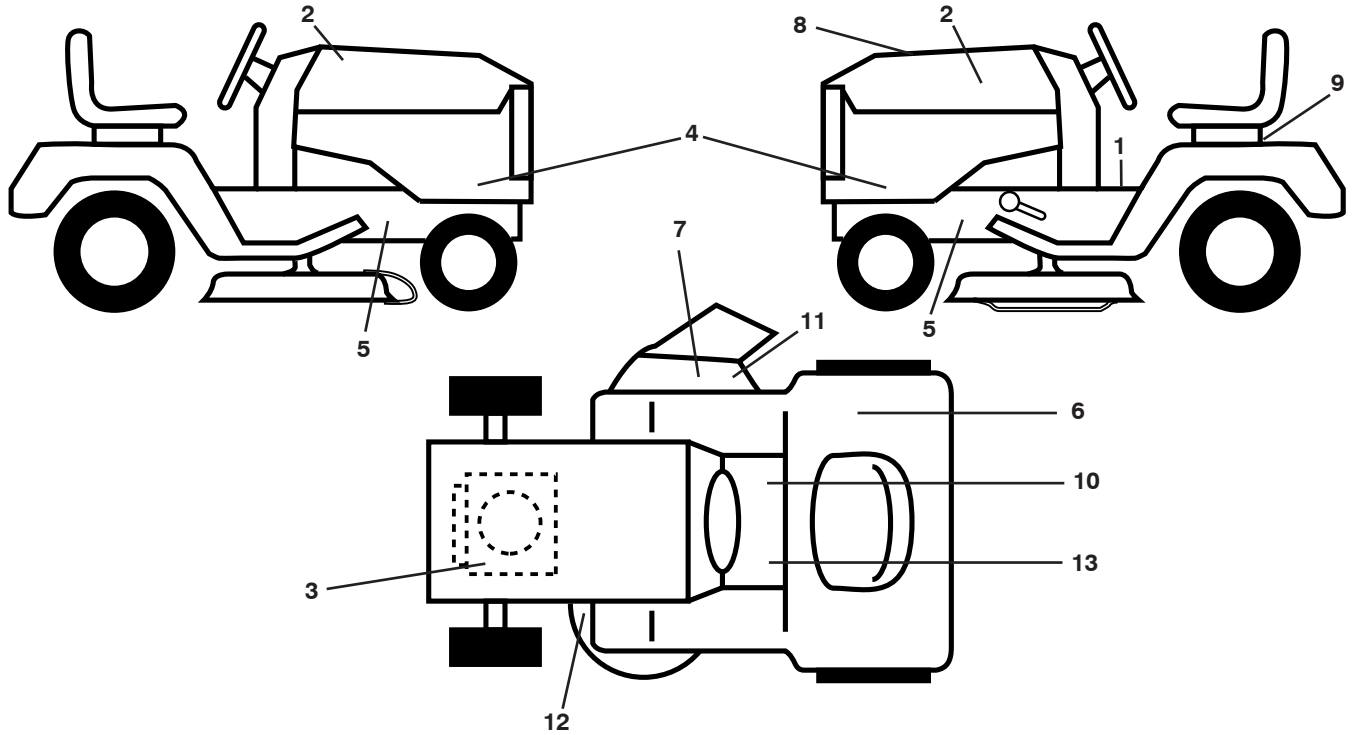

KEY NO.	PART NO.	DESCRIPTION
1	532 40 03-89	Decal, Operators
2	581 62 73-01	Decal, Hood
3	532 19 68-41	Decal, Warning Eng. Symbols
4	532 43 77-90	Decal, Hood Panel
5	532 15 97-36	Decal, Chassis Hot Muffler
6	532 18 04-32	Decal, Fender 100 DB/CE
7	532 18 21-66	Decal, Cutfinger CE
8	532 43 77-76	Decal, Rpl Kohl
9	532 14 50-05	Decal, Battery Dnge/Poi
10	532 14 08-37	Decal, Saddle Brake Parking
11	532 19 63-57	Decal, Warning

KEY NO.	PART NO.	DESCRIPTION
12	532 19 43-02	Decal, Mower V-Belt Schematic
13	532 15 97-37	Decal, Brake/Clutch Symbol
--	532 16 69-60	Decal, Bypass
--	532 16 25-98	Decal, Drawbar
--	532 43 96-81	Pad, Footrest, LH
--	532 43 99-66	Pad, Footrest, RH
--	532 44 41-43	Manual Oper. Euro
--	532 44 41-44	Manual Oper. Scand
--	532 44 41-45	Manual Oper. E-Bloc
--	532 44 41-46	Manual Oper. Baltic

WHEELS AND TIRES

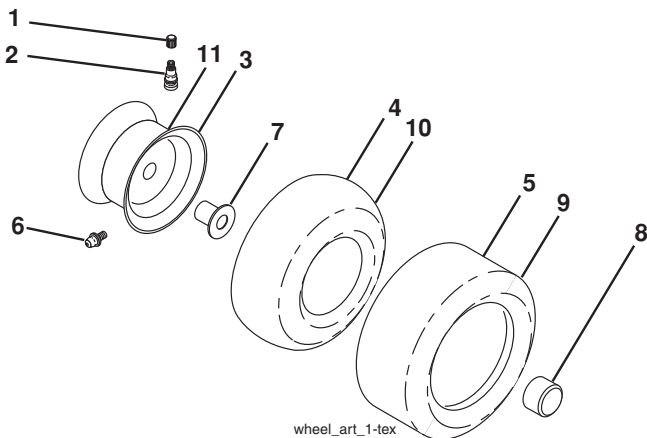

KEY NO.	PART NO.	DESCRIPTION
1	532 05 91-92	Cap Valve Tire
2	532 06 51-39	Stem Valve
3	532 13 83-36	Rim Asm 6" Front
4	532 05 99-04	Tube Front (Service Item Only)
5	532 43 71-54	Tire F T 15 x 6 0 - 6
6	532 12 49-57	Fitting Grease (Front Wheel Only)
7	532 12 49-59	Bearing Flange (Front Wheel Only)
8	532 17 50-39	Cap Axle Blk 1 50 x 1 00
9	532 42 05-31	Tire R 18 x 9.5-8 Turf Saver LT
10	532 12 49-26	Tube Rear (Service Item Only)
11	532 13 83-37	Rim Asm 8" Rear
--	532 14 43-34	Sealant, Tire (10 oz. Tube)

NOTE: All component dimensions given in U.S. inches
1 inch = 25.4 mm

TRACTOR - - MODEL NO. LTH151 (96041020101), PRODUCT NO. 960 41 02-01 SCHEMATIC 38

SCH10

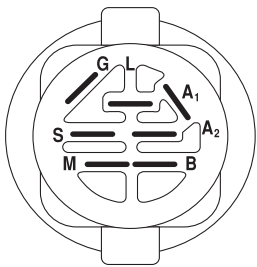
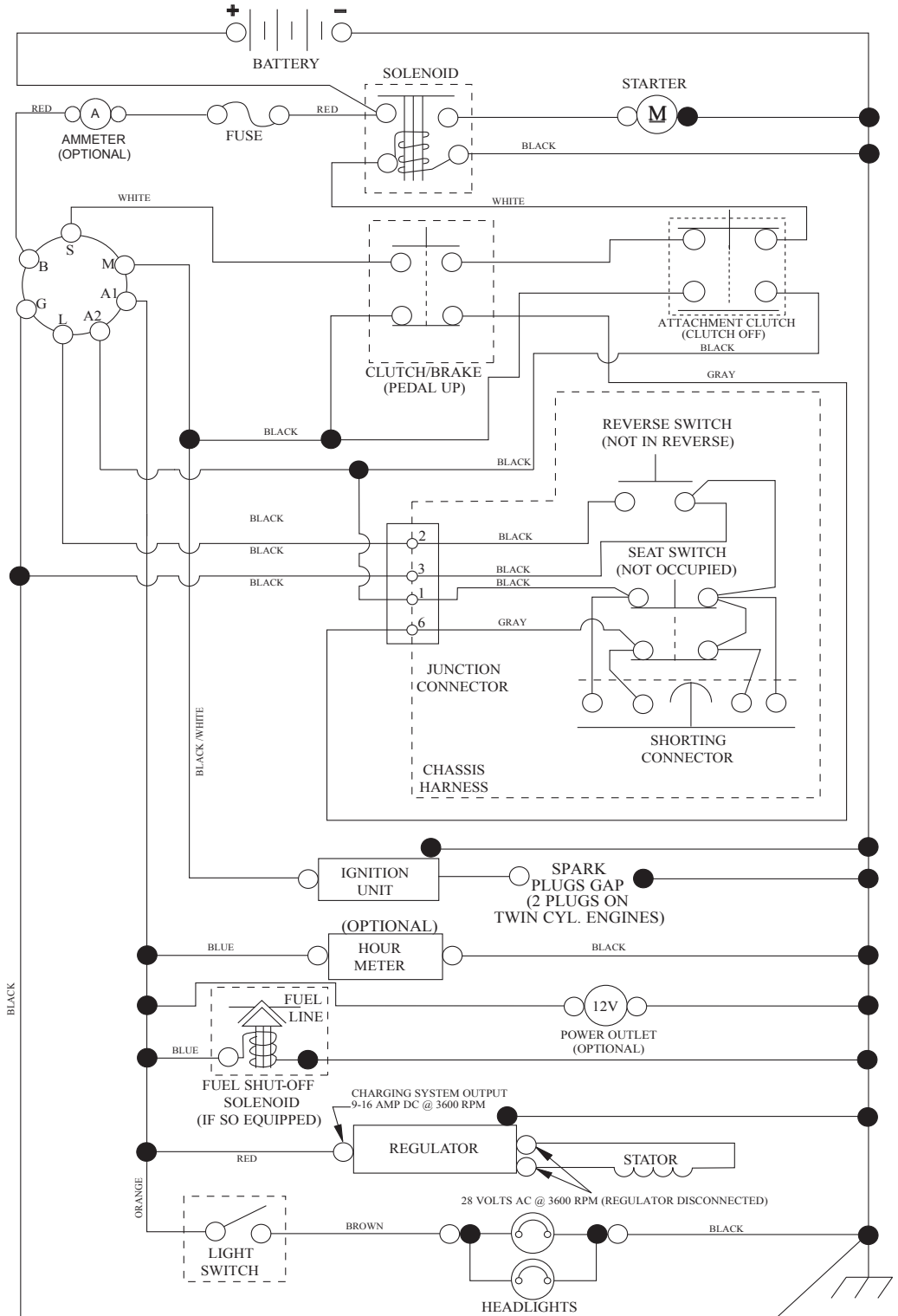

IGNITION SWITCH

POSITION	CIRCUIT	"MAKE"
OFF	M+G+A1	
RUN/OVERRIDE	B+A1	
RUN	B+A1	L+A2
START	B + S + A1	

03107

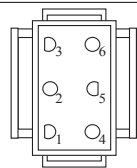

CHASSIS HARNESS CONNECTOR (MATING SIDE)

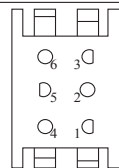

DASH HARNESS CONNECTOR (MATING SIDE)

WIRING INSULATED CLIPS
NOTE: IF WIRING INSULATED CLIPS WERE REMOVED FOR SERVICING OF UNIT, THEY SHOULD BE RE-INSTALLED TO PROPERLY SECURE YOUR WIRING.

NON-REMOVABLE CONNECTIONS

REMOVABLE CONNECTIONS

TRACTOR - - MODEL NO. LTH151 (96041020101), PRODUCT NO. 960 41 02-01
ELECTRICAL **32**

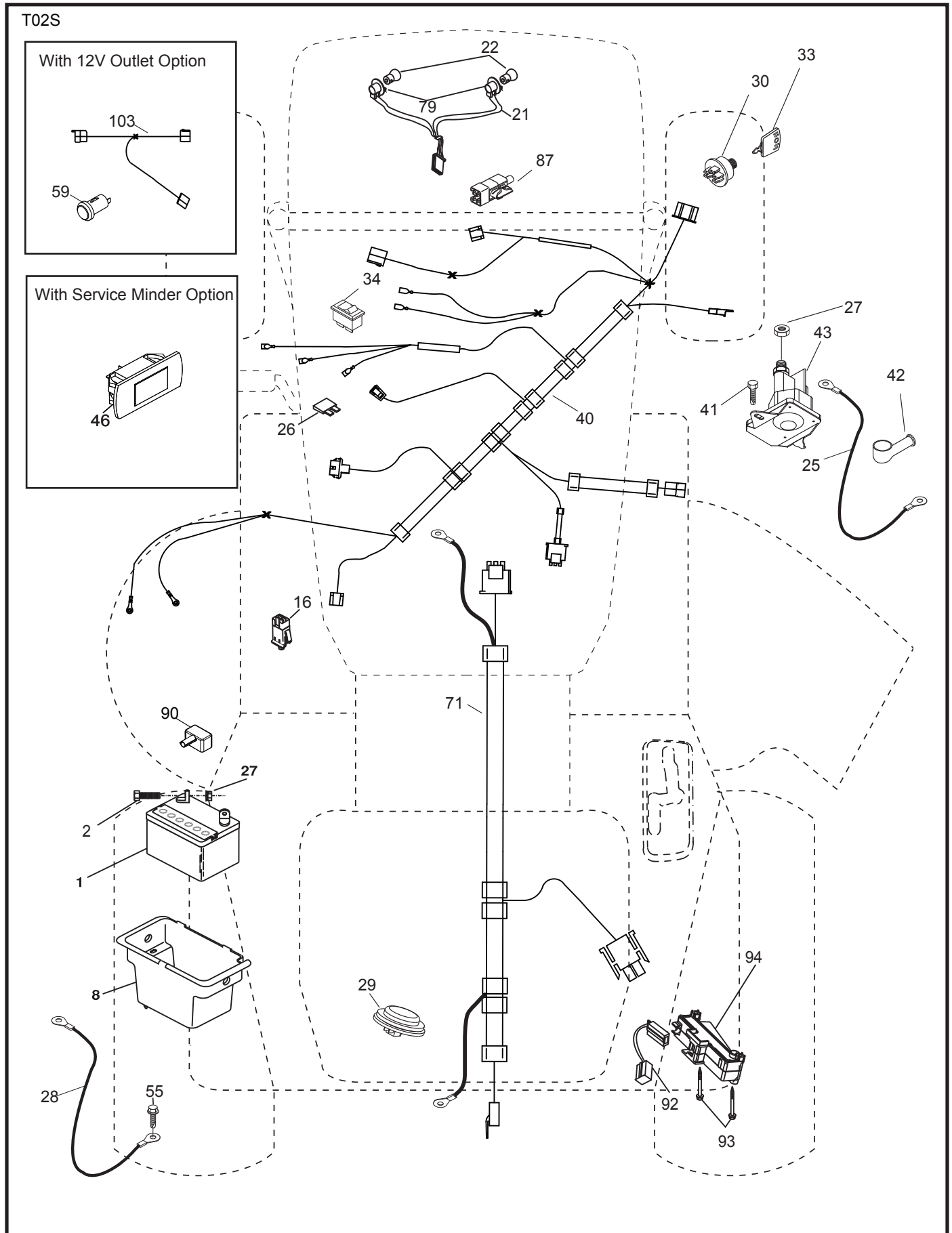

**TRACTOR - - MODEL NO. LTH151 (96041020101), PRODUCT NO. 960 41 02-01
ELECTRICAL 32**

KEY NO.	PART NO.	DESCRIPTION
1	532 16 34-65	Battery
2	874 76 04-12	Bolt Hex Head 1/4-20 x 3/4
8	532 19 32-28	Box Battery
16	532 17 61-38	Switch Interlock Push-In
21	532 40 02-52	Harness Socket Light W/4152J
22	532 00 41-52	Bulb Light
25	532 41 28-94	Cable Starter
26	532 17 51-58	Fuse
27	873 51 04-00	Nut Keps Hex 1/4-20 unc
28	532 19 88-85	Cable, Ground
29	532 40 15-45	Switch, Seat
30	532 19 33-50	Switch, Ign
33	532 41 19-35	Key/Chain
34	532 11 07-12	Switch Light / Reset
40	532 40 10-98	Harness Ign. Dash
41	817 72 04-08	Screw Thd Cut 1/4-20 x 1/2
42	532 13 15-63	Cover, Terminal
43	532 19 25-07	Solenoid
55	817 06 05-12	Screw Thdrol 5/16-18 x 3/4 TYTT
71	532 44 15-44	Harness Ign.
79	532 17 52-42	Socket Asm
87	532 19 78-02	Switch Interlock Clutch Cbl
90	532 43 53-95	Cover Terminal
92	532 19 66-15	Harness Pigtail Reverse Switch
93	532 19 25-40	Screw Plastite 10-14 x 2.0
94	532 19 18-34	Module Reverse ROS

NOTE: All component dimensions given in U.S. inches
1 inch = 25.4 mm

TRACTOR - - MODEL NO. LTH151 (96041020101), PRODUCT NO. 960 41 02-01
CHASSIS AND ENCLOSURES **39**

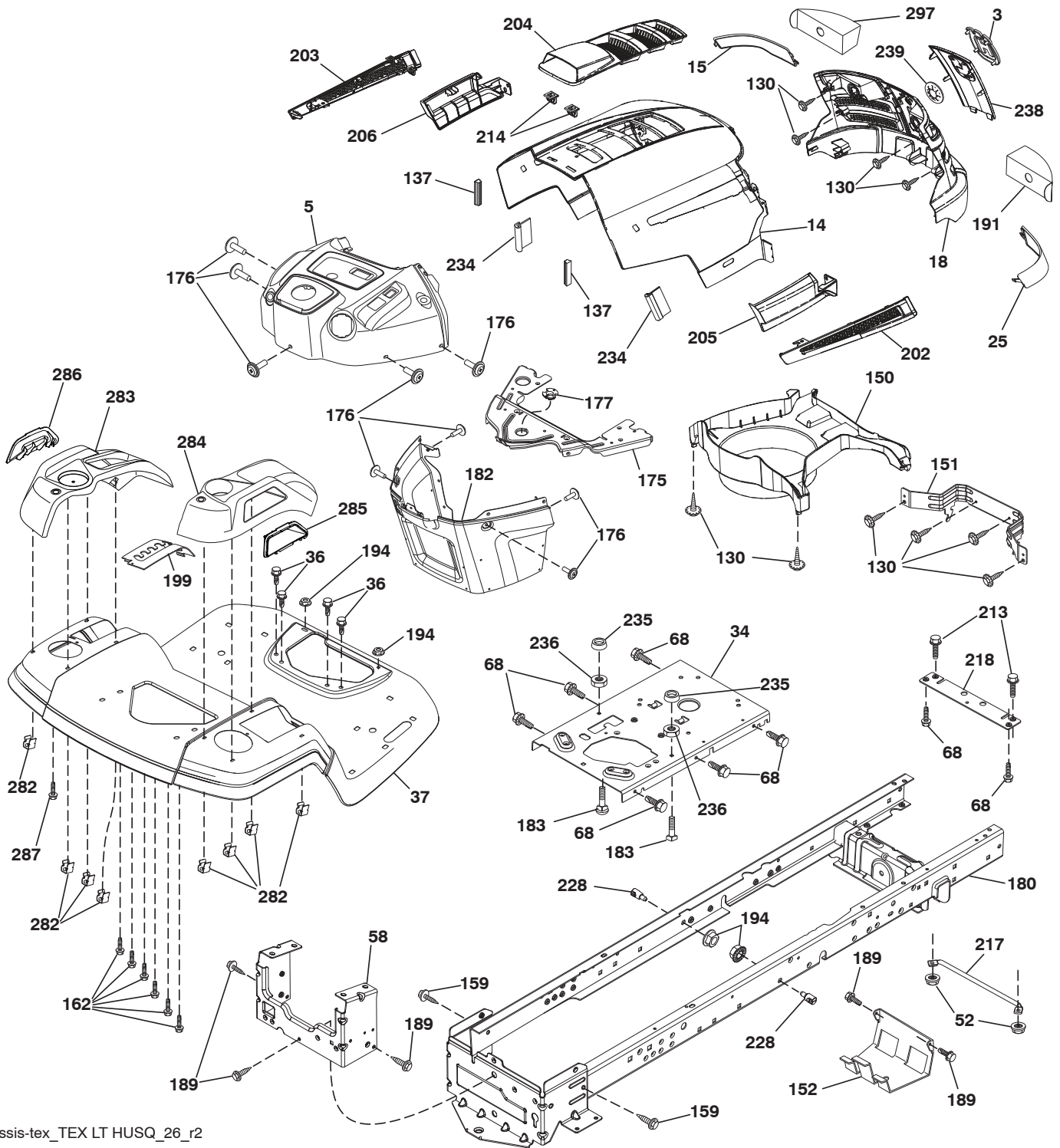

chassis-tex_TEX LT HUSQ_26_r2

**TRACTOR - - MODEL NO. LTH151 (96041020101), PRODUCT NO. 960 41 02-01
CHASSIS AND ENCLOSURES 39**

KEY NO.	PART NO.	DESCRIPTION
3	532 40 50-12	Logo
5	532 43 89-64	Dash
14	532 44 12-67	Hood
15	532 44 14-28	Lens LH
18	532 44 13-68	Grille
25	532 44 14-27	Lens RH
34	532 19 61-25	Plate Engine
36	817 06 05-12	Screw 5/16-18 x 3/4
37	532 44 12-66	Fender
52	873 68 05-00	Nut Crown Lock 5/16
58	532 41 22-80	Drawbar, Upper
68	817 49 05-08	Screw THDROL 5/16-18 x 1/2
130	532 41 63-58	Screw 10 x .750 BOSThread
137	532 40 75-90	Bumper Dash
150	532 40 75-37	Air Duct
151	532 40 78-07	Bracket Pivot
152	532 19 95-35	Shield Browning
159	817 00 06-12	Screw 3/8-7/16 x 3/4
162	532 14 24-32	Screw
175	532 19 94-72	Crossmember
176	532 40 07-76	Screw 10-24 x 5/8
177	532 19 52-28	Bushing Steering
180	532 41 50-63	Chassis
182	532 40 71-76	Dash Lower
183	874 52 05-20	Bolt 5/16-18 x 1-1/4
189	817 00 05-12	Screw 5/16-18 x 3/4
191	532 41 65-01	Insert Reflective RH
194	873 90 05-00	Nut Lock Hex Flange 5/16-18
199	532 41 34-85	Plate Deck Lift
202	532 44 13-42	Vent Side Hood RH
203	532 44 13-43	Vent Side Hood LH
204	532 44 13-75	Vent Top Hood
205	532 44 13-44	Skirt Side RH
206	532 43 13-45	Skirt Side LH
213	874 76 05-12	Bolt 5/16-18 x 3/4
214	532 19 91-45	Clip Retainer
217	532 40 91-67	Rod Pivot Hood
218	532 19 63-95	X-Piece Hood Stop
228	532 19 51-61	Stud Fastener
234	532 40 47-42	Bumper Hood
235	532 40 61-29	Spacer Fender
236	873 93 05-00	Nut Lock 5/16-18 unc
238	532 44 13-74	Trim
239	532 40 48-83	Clip Tinnerman
282	532 41 41-10	Clip Retainer Console
283	532 44 20-39	Console Deck Lift
284	532 44 41-64	Console Shift
285	532 41 63-15	Console Insert RH
286	532 41 63-17	Console Insert LH
287	817 60 04-06	Screw Hex Washhead 1/4-20 x 3/8
297	532 40 66-65	Insert Reflective LH
- - -	532 43 99-76	Plug Dash SRVMNDR

NOTE: All component dimensions given in U.S. inches
1 inch = 25.4 mm

TRACTOR - - MODEL NO. LTH151 (96041020101), PRODUCT NO. 960 41 02-01
DRIVE **40**

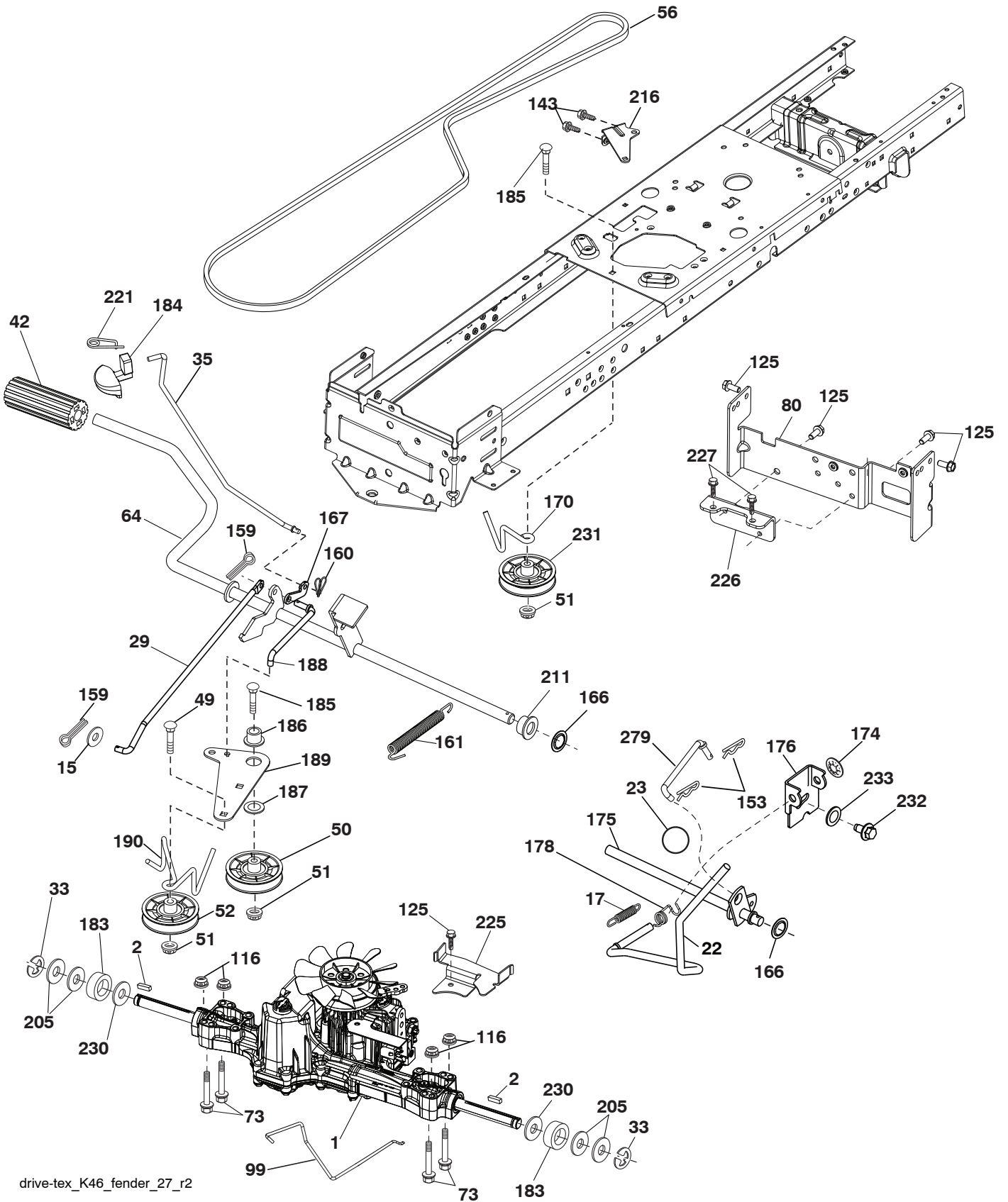

drive-tex_K46_fender_27_r2

**TRACTOR - - MODEL NO. LTH151 (96041020101), PRODUCT NO. 960 41 02-01
DRIVE 40**

KEY NO.	PART NO.	DESCRIPTION
1	-----	Transaxle, Tufftorq K46 BA (408214) (Order parts from transaxle manufacturer)
2	532 12 35-83	Key
15	819 13 13-16	Washer 13/32 x 13/16 x 16 Ga.
17	532 41 36-78	Spring, Brake
22	532 19 76-60	Rod Shift
23	532 12 12-74	Knob
29	532 40 38-06	Rod, Brake
33	812 00 00-01	Ring E
35	532 40 10-31	Rod, Brake, Park
42	532 12 48-72	Cover, Foot Pedal
49	872 11 06-14	Bolt
50	532 19 43-27	Pulley Idler Flat
51	873 90 06-00	Lock Nut 3/8-16
52	532 19 43-26	Idler V-Groove 910" Offset
56	532 13 09-69	V-Belt, Drive
64	532 19 62-00	Shaft Asm. Pedal Brake Control
73	874 49 05-44	Bolt Hex Flghd 5/16-18 x 2-1/2 Gr. 5
80	532 44 06-19	Strap Torque
99	532 41 57-42	Rod Bypass
116	873 90 05-00	Nut Lock Hex Flange 5/16-18
125	817 00 05-12	Screw 5/16-18 x 3/4
143	817 49 05-08	Screw Thdrol 5/16-18 x 1/2
153	532 12 47-88	Retainer Spring
159	876 02 04-12	Pin Cotter 1/8 x 3/4
160	532 16 94-84	Retainer Clip
161	532 10 57-09	Spring, Return, Clutch
166	532 42 91-64	Nut Push
167	532 40 52-57	Latch Brake Parking
170	532 41 34-30	Keeper Belt Centerspan
174	532 19 72-89	Nut Push
175	532 40 85-39	Shaft Asm Shift
176	532 19 62-14	Arm Clevis Rod Shift
178	532 19 74-56	Spring Shift
183	532 13 70-57	Spacer Split
184	532 44 14-07	Handle Parking Brake
185	872 11 06-22	Bolt Rdhd Sqnk 3/8-16 x 2-1/2
186	532 19 43-21	Spacer Retainer
187	819 13 32-10	Washer
188	532 19 43-23	Link Clutch Ground Drive
189	532 19 43-17	Bellcrank Ground Drive
190	532 19 43-18	Keeper Bellcrank Ground Drive
205	532 12 17-48	Washer
211	532 19 62-12	Bushing Brake Shaft
216	532 19 61-31	Bracket Pulley Idler
221	532 40 31-87	Retainer Spring Clip Handle
225	532 40 33-19	Keeper Belt Trans.
226	532 40 15-64	Bracket Mount Torque
227	817 49 05-12	Screw Thdrol 5/16-18 x 3/4
230	532 18 89-67	Washer Hardened
231	532 40 72-87	Idler V-Groove
232	874 78 07-16	Bolt 7/16-14 x 1 Gr. 5
233	532 40 52-96	Washer Serrated
279	532 41 31-50	Link Shift

NOTE: All component dimensions given in U.S. inches
1 inch = 25.4 mm

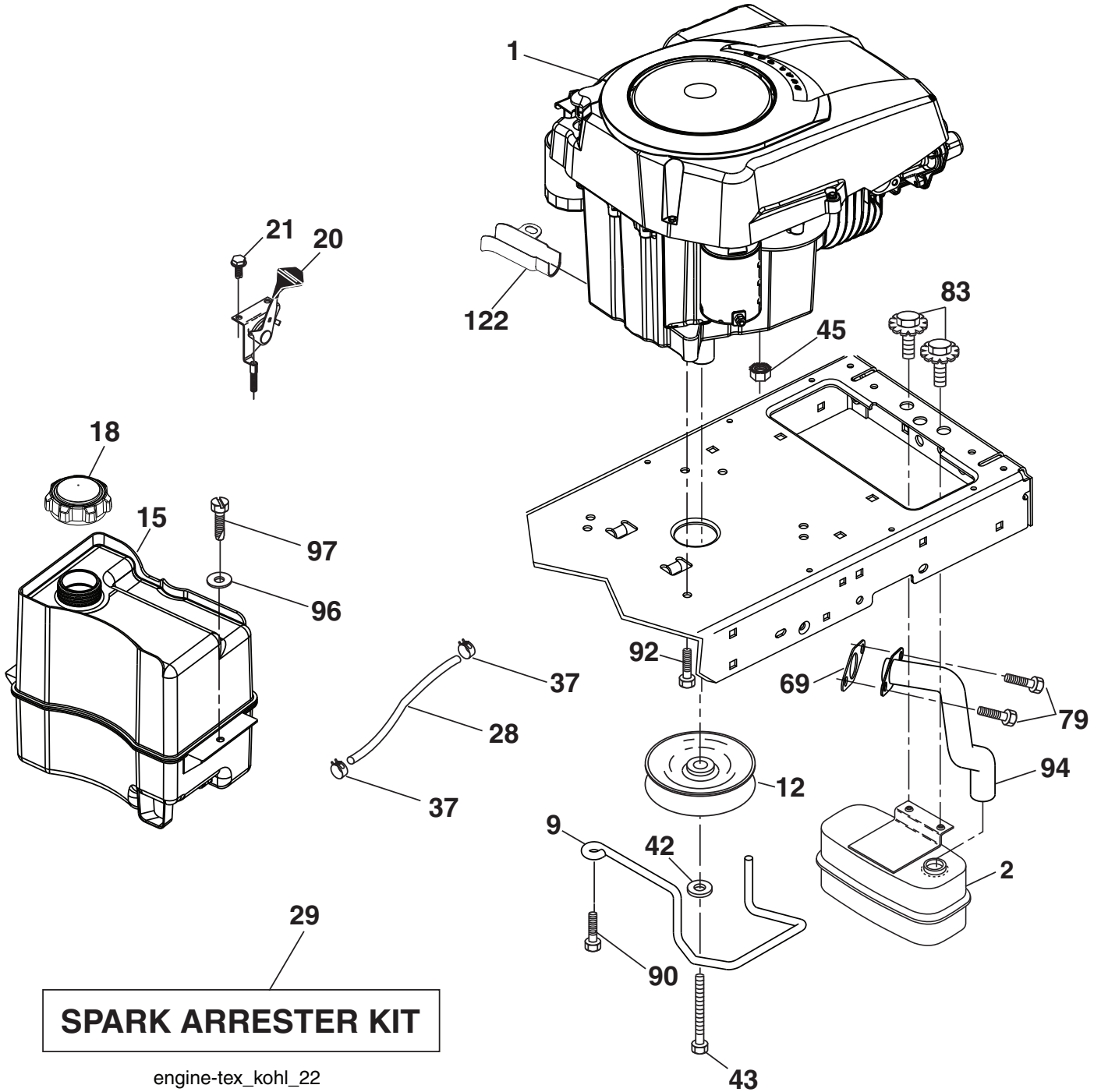

**TRACTOR - - MODEL NO. LTH151 (96041020101), PRODUCT NO. 960 41 02-01
ENGINE 24**

KEY NO.	PART NO.	DESCRIPTION
1	-----	Engine Kohler Model No. SV470-0212 (422739) (Order parts from engine manufacturer)
2	532 18 86-55	Muffler
9	532 19 43-20	Keeper Belt Engine
12	532 40 54-71	Pulley Engine
15	532 40 75-45	Tank Fuel 1.5
18	532 43 02-20	Cap Fuel
20	532 18 38-97	Control Throttle
21	532 41 63-58	Screw #10 x .750 BOS Thread
28	532 13 70-40	Fuel Line
29	532 13 71-80	Spark Arrester Kit
37	532 12 34-87	Clamp Hose
42	810 04 07-00	Washer
43	532 17 39-37	Bolt Hex 7/16-20 x 4 Gr. 5
45	873 51 04-00	Nut Keps Hex 1/4-20 unc
69	532 18 59-09	Gasket
79	532 19 23-34	Screw Socket 5/16-18 x .75
83	532 17 18-77	Bolt 5/16-18 unc x 3/4 w/Sems
90	817 00 06-16	Screw 3/8-16 x 1
92	817 12 06-16	Screw 3/8-16 x 1
94	532 18 86-54	Tube Exhaust
96	819 09 14-16	Washer 9/32 x 7/8 x 16 Ga.
97	817 67 04-12	Screw Hexwsh Thdrol 1/4-20 x 3/4
122	532 42 19-22	Extension Drain Oil

NOTE: All component dimensions given in U.S. inches
1 inch = 25.4 mm

**TRACTOR - - MODEL NO. LTH151 (96041020101), PRODUCT NO. 960 41 02-01
STEERING ASSEMBLY 41**

KEY NO.	PART NO.	DESCRIPTION
1	532 43 97-40	Wheel, Steering Husq SR
2	532 41 81-68	Axle Asm., Front
4	532 40 30-87	Spindle Asm., LH
5	532 40 30-88	Spindle Asm., RH
6	532 12 49-31	Bearing, Race Thrust Hardened
7	532 12 17-48	Washer 25/32 x 1-5/8 x 16 Ga.
8	812 00 00-29	Ring, Klip #T5304-75
9	532 12 12-32	Cap, Spindle
13	532 12 17-49	Washer, 25/32 x 1-1/4 x 16 Ga.
14	810 04 06-00	Washer, Lock Hvy Hlcl Spr 3/8
15	873 54 06-00	Nut, Crown Lock 3/8-24 unf
16	532 42 93-73	Shaft Steering
19	532 19 47-29	Plate Steering
20	532 44 14-25	Boot, Steering
21	532 18 67-37	Adapter, Wheel Steering
22	532 42 05-37	Steering Support Lower
26	532 43 97-43	Insert, Wheel Steering Husq SR
28	817 00 06-12	Screw 3/8-16 x 3/4
33	810 04 05-00	Washer Lock 5/16
35	532 19 47-32	Gear, Sector Plate
45	819 11 38-12	Washer 11/32 x 3/8 x 12 Ga.
53	532 18 89-67	WasherHardened.793x1.637x.060
57	532 40 74-65	Bracket Upstop
58	532 19 47-47	Bolt Shoulder Sector Pivot CFM
59	532 19 47-48	Washer Thrust Sector Steering
60	873 97 10-00	Nut Flange Lock 5/8-11
61	532 19 47-40	Draglink, LH
62	532 19 47-41	Draglink, RH
63	817 00 05-12	Screw 5/16-18 x 3/4
64	532 19 98-49	Retainer Clip Spring Steering
66	871 02 07-48	Bolt Hex Fghd 7/16-14 x 3 Serr
67	532 19 47-37	Bushing PM Front Axle
68	873 90 07-00	Nut Lock Flange 7/16-14 Gr. 5
69	532 19 91-62	Washer 1.5 x .505 x .118
70	532 19 61-97	Bracket Deck Susp. Front
71	532 19 07-52	Shaft Extension Steering
72	532 42 89-82	Bolt 5/16-18 unc x 4 w/Patch
74	532 12 49-37	Bearing

NOTE: All component dimensions given in U.S. inches
1 inch = 25.4 mm

**TRACTOR - - MODEL NO. LTH151 (96041020101), PRODUCT NO. 960 41 02-01
MOWER DECK 44**

KEY NO.	PART NO.	DESCRIPTION	KEY NO.	PART NO.	DESCRIPTION
1	532 44 41-63	Mower Housing	60	532 19 94-71	Arm Brake Mower
6	532 19 51-86	Arm Suspension	63	532 19 94-70	Arm Brake Mower
7	532 41 63-58	Screw #10 x .750 BOS Thread	64	532 19 97-90	Link Brake
8	532 19 30-03	Bolt/Washer asm 7/16-20 unf	67	532 40 30-12	Handle Clutch Cable
11	532 19 39-57	Blade, Premium, (For better wear when mulching) 38" 3NI	68	532 40 83-81	V-Belt
13	532 19 28-72	Shaft Assembly, Mandrel	69	872 14 05-05	Bolt
14	532 18 72-81	Housing, Mandrel	70	532 40 12-46	Clutch Asm Manual
15	532 11 04-85	Bearing, Ball, Mandrel	115	872 11 05-05	Bolt Carr 5/16-18 x 5/8
19	532 19 65-39	Bolt, Shoulder	122	532 19 72-58	Keeper Belt Engine LH
21	873 68 05-00	Nut, Crownlock 5/16-18 unc	123	532 19 72-59	Keeper Belt Engine RH
23	532 19 25-57	Bracket, Deflector	144	532 19 34-14	Keeper Belt
24	532 10 53-04	Cap, Sleeve	145	532 19 31-97	Pulley, Idler, Flat
25	532 19 70-26	Spring, Torsion, Deflector	147	532 40 18-72	Spring Return
26	532 11 04-52	Nut, Push	152	532 43 51-11	Manual Clutch Cable
27	532 40 14-72	Shield, Deflector	188	532 19 51-61	Stud Fastener
29	532 13 14-91	Rod, Hinge	189	873 90 05-00	Nut Lock Hex Flange
30	532 17 39-84	Screw Thdrol Rolling Wsh Hd	195	817 00 06-12	Screw 3/8-16 x 3/4
31	532 18 76-90	Washer, Spacer	199	532 40 00-95	Baffle Vortex
32	532 19 97-89	Pulley, Mandrel	209	819 13 32-10	Washer 13/32 x 2 x 10
33	532 40 02-34	Nut, Toplock, Flanged	241	532 15 29-27	Screw
34	872 11 06-12	Bolt Carr Sh. 3/8-16 x 1-1/2 Gr. 5	242	532 41 55-98	Port Washout
37	819 13 13-16	Washer	--	532 19 28-70	Mandrel Assembly (Includes hous- ing, shaft assembly, and bearing only - pulley/nut/washer and blade bolt/washers not included)
38	532 19 95-41	Keeper Belt LH Mandrel	--	532 44 33-59	Replacement Mower, Complete
40	873 90 06-00	Nut, Lock Flg. 3/8-16 unc			
42	532 19 84-10	Spring Torsion Brake			
43	532 19 72-56	Spring Torsion Retainer			
46	532 13 77-29	Screw 1/4-20 x 5/8			
55	532 19 72-49	Arm, Idler			
56	532 19 90-92	Spacer, Retainer			
57	817 00 06-16	Screw 3/8-16 x 1			
59	532 14 10-43	Guard, Tuv Idler			

NOTE: All component dimensions given in U.S. inches
1 inch = 25.4 mm

**TRACTOR - - MODEL NO. LTH151 (96041020101), PRODUCT NO. 960 41 02-01
MOWER DECK 44**

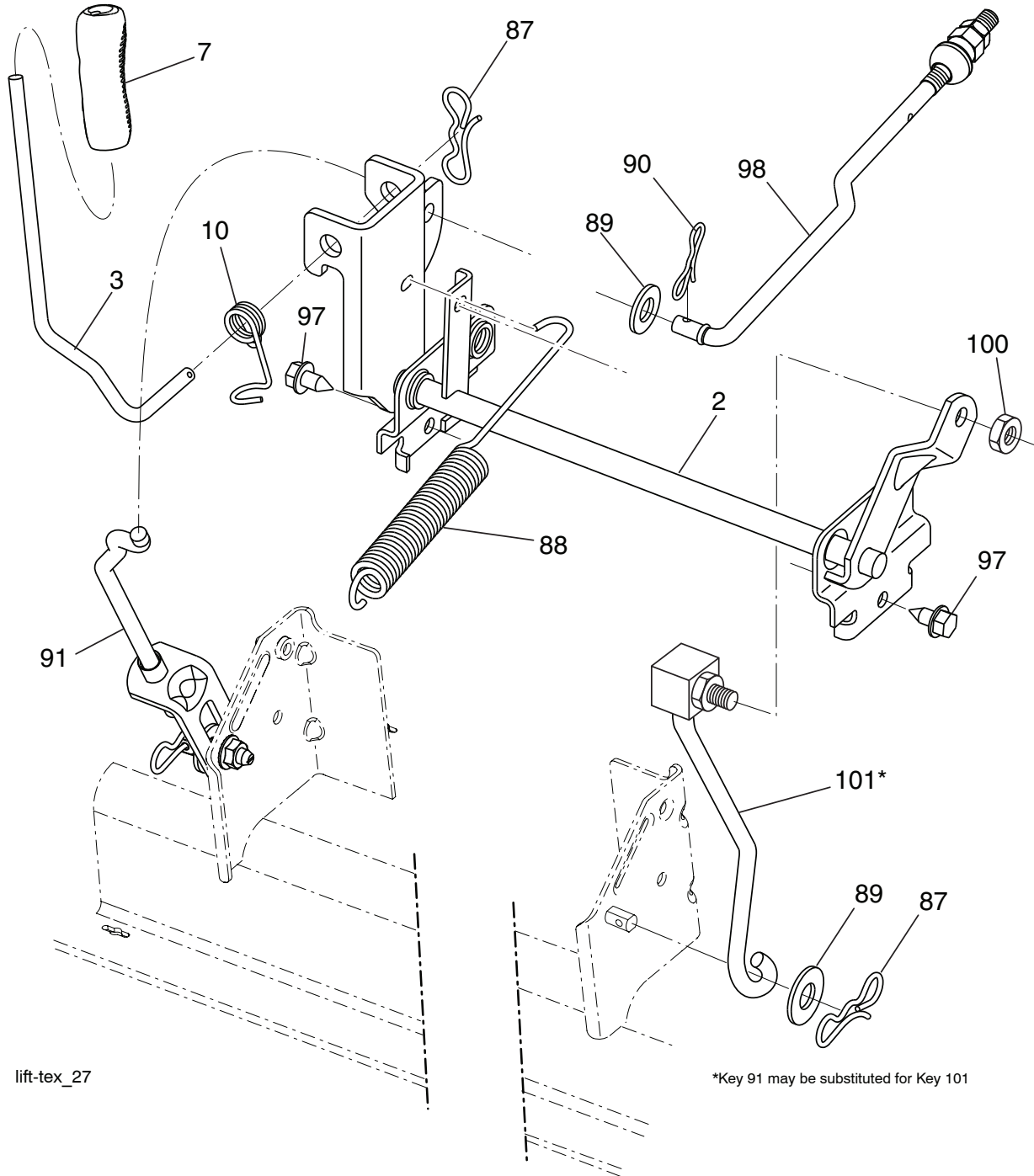

lift-tex_27

*Key 91 may be substituted for Key 101

KEY NO.	PART NO.	DESCRIPTION
2	532 42 20-27	Shaft Asm., Lift
3	532 19 52-31	Lever Asm., Lift RH
7	532 41 15-55	Grip, Lever
10	532 19 63-14	Spring Torsion
87	532 19 42-09	Pin Cotter 7/16 Bow Tie Lock
88	532 41 07-10	Spring Lift Assist.
89	819 19 19-12	Washer Clear Zinc
90	532 19 42-08	Pin Cotter 5/16 Bow Tie Lock

KEY NO.	PART NO.	DESCRIPTION
91	532 19 51-81	Link Lift Susp Mower Rear
97	817 00 06-12	Screw 3/8-16 x .75
98	532 19 52-70	Link Lift Susp. Front Mower
100	873 93 06-00	Nut Centerlock 3/8-16
101	532 40 70-03	Link Asm. Lift FXD

NOTE: All component dimensions given in U.S. inches
1 inch = 25.4 mm

**TRACTOR - - MODEL NO. LTH151 (96041020101), PRODUCT NO. 960 41 02-01
SEAT ASSEMBLY 42**

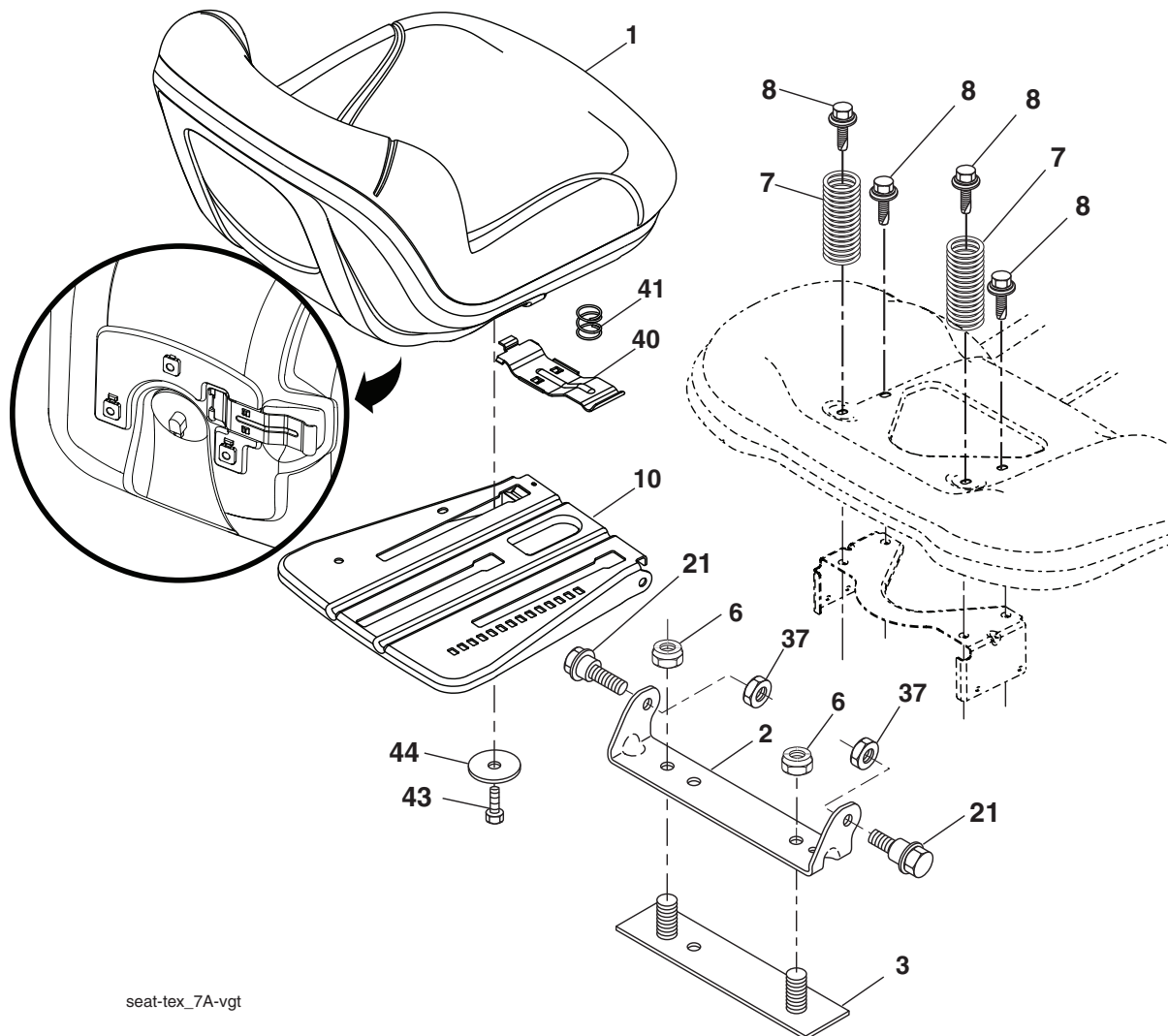

seat-tex_7A-vgt

KEY NO.	PART NO.	DESCRIPTION
1	532 43 98-19	Seat
2	532 18 01-66	Bracket Pivot Fender
3	532 14 06-75	Strap, Asm Fender
6	873 80 06-00	Nut, Lock W/Ins. 3/8-16 unc
7	532 12 41-81	Spring, Seat Cprsn
8	532 17 18-77	Bolt 5/16-18 unc x 3/4 w/Sems
10	532 19 69-77	Pan, Seat
21	532 17 18-52	Bolt, Shoulder 5/16-18
37	873 80 05-00	Nut, Lock 5/16-18 unc

KEY NO.	PART NO.	DESCRIPTION
40	532 19 76-61	Handle Slide
41	532 19 82-00	Spring Latch
43	874 76 06-12	Bolt Fin Hex 3/8-16 unc x 3/4
44	819 13 38-12	Washer 13/32 x 2-3/8 x 12 Ga.

NOTE: All component dimensions given in U.S. inches
1 inch = 25.4 mm

