

# **ILLUSTRATED PARTS LIST**

**MODEL NO. 96041022300**

**CUSTOMER CATALOG NO. LTH2142**

**PRODUCT NO. 960 41 02-23**

**TRACTOR - - MODEL NO. LTH2142 (96041022300), PRODUCT NO. 960 41 02-23  
DECALS 27**

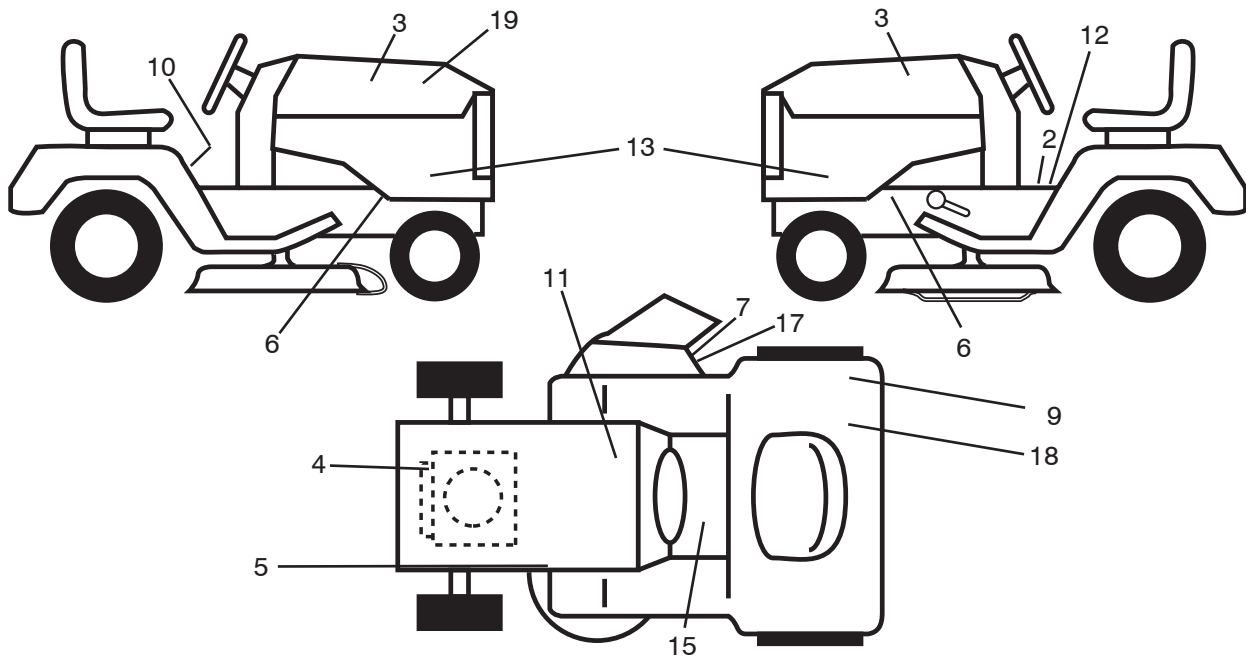

KEY NO.	PART NO.	DESCRIPTION	KEY NO.	PART NO.	DESCRIPTION
2	532 14 08-37	Decal, Brake Parking Sandle	13	532 44 15-55	Decal, Sidepnl
3	581 62 73-01	Decal, Hood	15	532 15 97-37	Decal, Brake/Clutch Symbol
4	532 19 68-41	Decal, Warning Engine Syms	17	532 19 63-57	Decal, Cutfinger Warning
5	532 16 03-96	Decal, V-Belt Sch.	18	532 12 44-33	Decal, 80 DBA
6	532 15 97-36	Decal, Chassis Hot Muffler	19	532 43 37-74	Decal, Replacement
7	532 18 21-66	Decal, Mower Cutfinger Symbol	--	532 16 25-98	Decal, Drawbar Load Limit
9	532 16 88-69	Decal, Tick Mark	--	532 16 69-60	Decal, Bypass Lt Hydro
10	532 40 03-89	Decal, Warning Symbols CE	--	532 41 08-05	Pad, Footrest LH
11	532 14 50-05	Decal, Bat Dan/Poi P/L Sym	--	532 41 08-06	Pad, Footrest RH
12	532 17 83-02	Decal, Oper. Cruise Symbols	--	532 44 15-83	Manual, Operator's (English)

**WHEELS & TIRES**

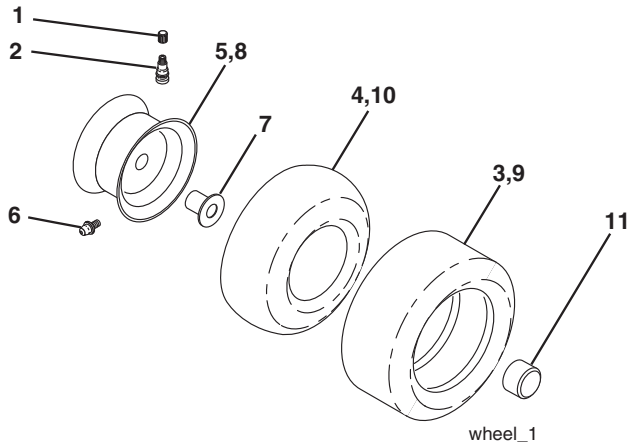

KEY NO.	PART NO.	DESCRIPTION
1	532 05 91-92	Cap Valve Tire
2	532 06 51-39	Stem Valve
3	532 10 62-22	Tire F Ts 15 x 6 0 - 6 Service
4	532 05 99-04	Tube Front (Service Item Only)
5	532 13 83-36	Rim Asm 6" Front Silver Service
6	532 12 49-57	Fitting Grease (Front Wheel Only)
7	532 12 49-59	Bearing Flange (Front Wheel Only)
8	532 13 83-37	Rim Asm 8" Rear Silver Service
9	532 12 20-82	Tire R Ts 20 x 10-8 C Service
10	532 12 49-26	Tube Rear (Service Item Only)
11	532 17 50-39	Cap Axle Blk 1 50 x 1 00
--	532 14 43-34	Sealant, Tire (10 oz. tube)

NOTE: All component dimensions given in U.S. inches  
1 inch = 25.4 mm

# TRACTOR - - MODEL NO. LTH2142 (96041022300), PRODUCT NO. 960 41 02-23 SCHEMATIC 38

SCH12

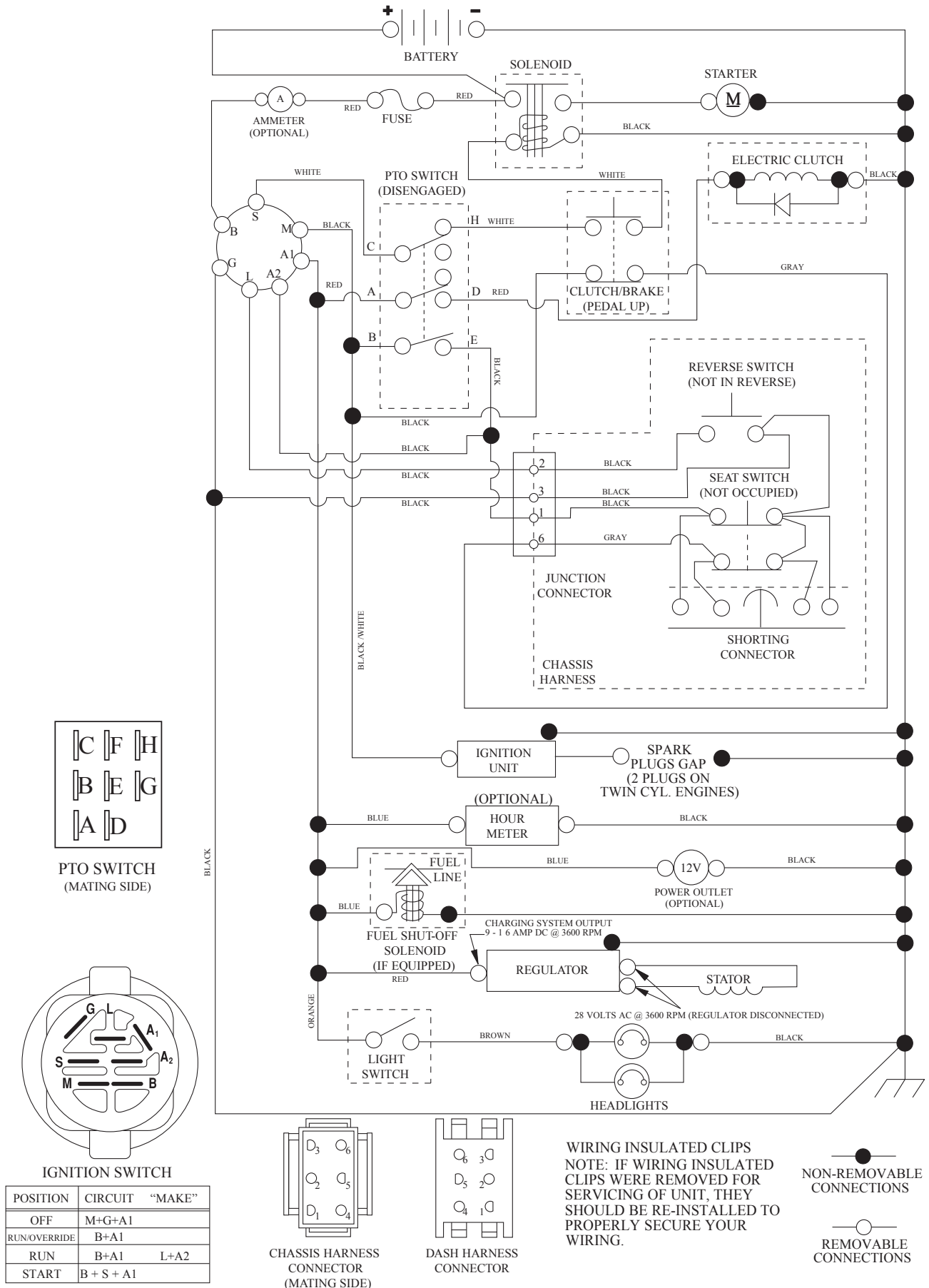

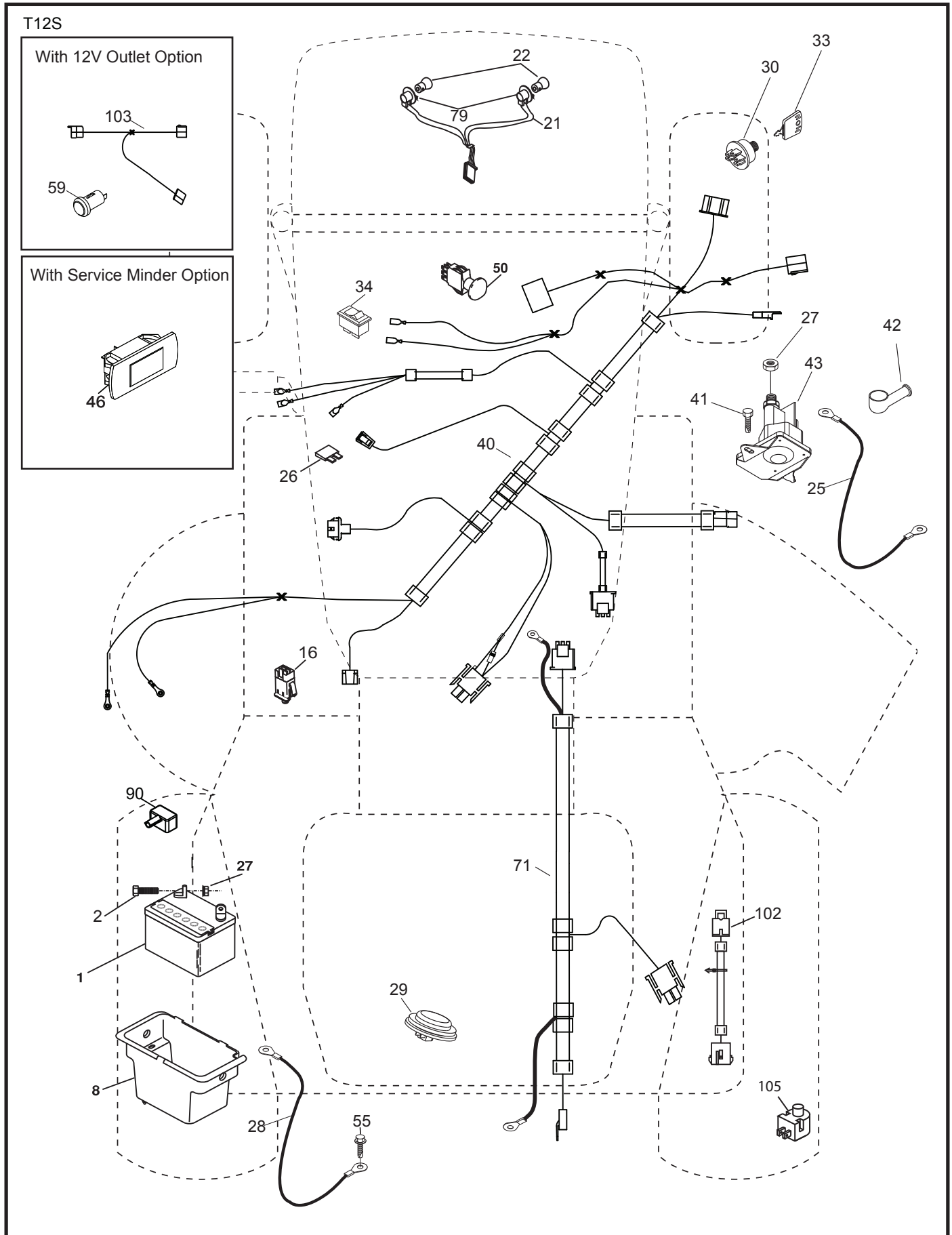

**TRACTOR - - MODEL NO. LTH2142 (96041022300), PRODUCT NO. 960 41 02-23  
ELECTRICAL 32**

<b>KEY NO.</b>	<b>PART NO.</b>	<b>DESCRIPTION</b>
1	532 16 34-65	Battery
2	874 76 04-12	Bolt Hex Hd 1/4-20 unc x 3/4
8	532 19 32-28	Box Battery
16	532 17 61-38	Switch Interlock
21	532 40 02-52	Harness Asm Light w/4152J
22	532 00 41-52	Bulb Light #1156
25	532 41 28-94	Cable Battery 6 Ga. Red 14.5
26	532 17 51-58	Fuse 20 AMP
27	873 51 04-00	Nut Keps Hex 1/4-20 Unc
28	532 19 88-85	Cable 18" Rear. BATT.
29	532 40 15-45	Switch Seat
30	532 19 33-50	Switch Ignition
33	532 41 19-33	Key/Chain
34	532 11 07-12	Switch Light
40	532 40 11-04	Harness Ign.
41	817 72 04-08	Bolt Hex Hd. Fin 1/4-20 x 1/2 Gr. 5
42	532 13 15-63	Cover Terminal Red
43	532 19 25-07	Solenoid
46	532 40 17-63	Hourmeter
50	532 17 46-51	Switch PTO
55	817 06 05-12	Screw 5/16-18 x 3/4
71	532 40 04-49	Harness Ign. Chass. Tex
79	532 17 52-42	Socket, Asm. Bulb
90	532 43 53-95	Cover Terminal Battery
102	532 40 44-54	Harness Pigtail K46 TEX ROS
105	532 40 75-68	Switch Reverse TT Pedal Control

**NOTE:** All component dimensions given in U.S. inches  
1 inch = 25.4 mm.

TRACTOR - - MODEL NO. LTH2142 (96041022300), PRODUCT NO. 960 41 02-23  
CHASSIS AND ENCLOSURES **39**

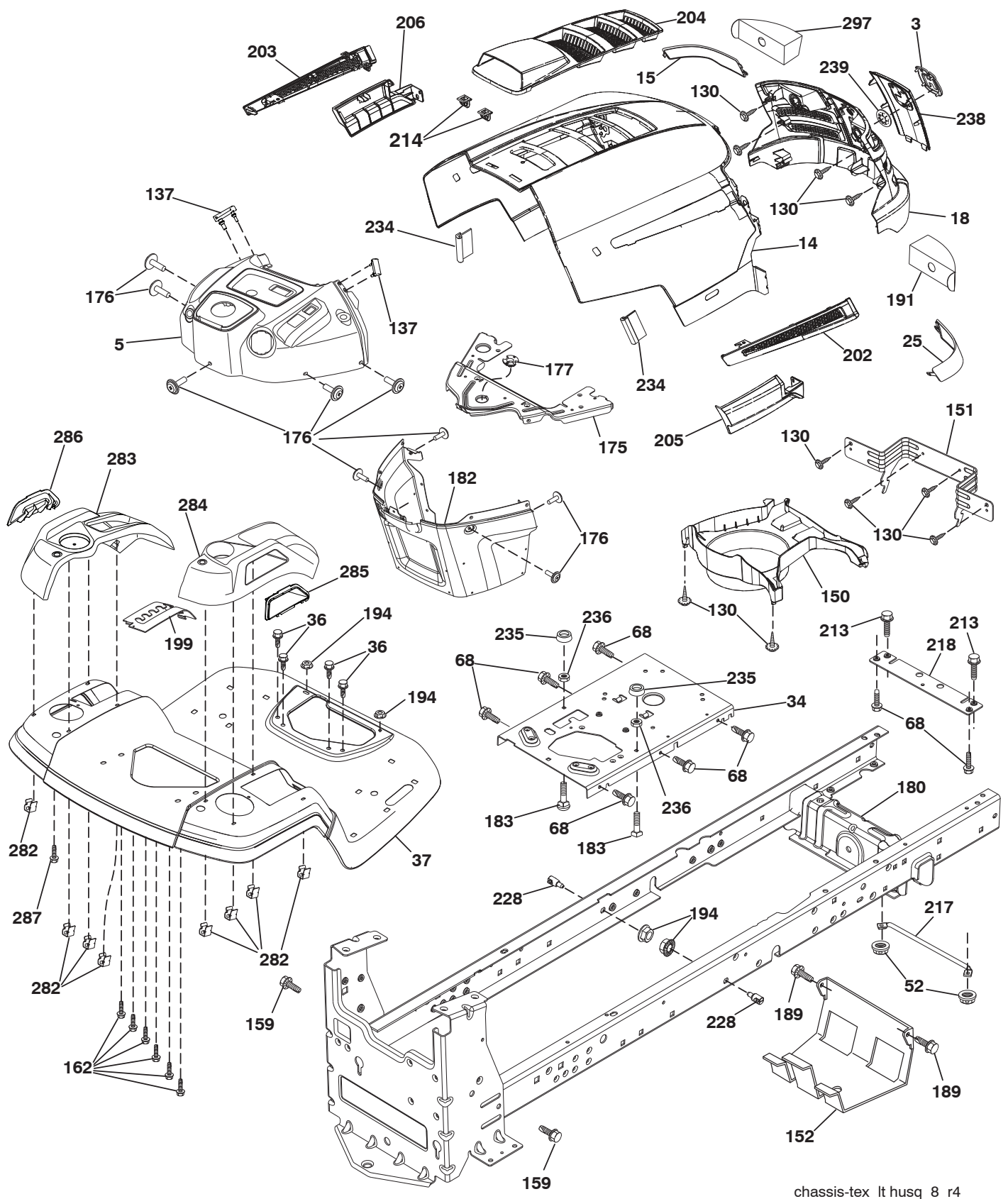

chassis-tex\_lt husq\_8\_r4

**TRACTOR - - MODEL NO. LTH2142 (96041022300), PRODUCT NO. 960 41 02-23  
CHASSIS AND ENCLOSURES 39**

KEY NO.	PART NO.	DESCRIPTION	KEY NO.	PART NO.	DESCRIPTION
3	532 40 50-12	Logo	199	532 41 34-85	Plate Deck Lift
5	532 40 75-94	Dash	202	532 41 10-75	Vent Side Hood RH
14	532 41 10-73	Hood	203	532 41 10-74	Vent Side Hood LH
15	532 41 10-79	Lens LH	204	532 41 17-68	Vent Top Hood
18	532 42 69-63	Grille	205	532 41 10-76	Skirt Side RH
25	532 41 10-78	Lens RH	206	532 41 10-77	Skirt Side LH
34	532 19 61-25	Plate Engine	213	874 76 05-12	Bolt 5/16-18 x 3/4
36	817 06 05-12	Screw 5/16-18 x 3/4	214	532 19 91-45	Clip Retainer
37	532 41 63-07	Fender	217	532 40 91-67	Rod Pivot Hood
52	873 68 05-00	Nut Crown Lock 5/16	218	532 19 63-95	X-Piece Hood Stop
68	817 49 05-08	Screw THDROL 5/16-18 x 1/2	228	532 19 51-61	Stud Fastener
130	532 41 63-58	Screw #10 x 0.750 BOS Thread	234	532 40 47-42	Bumper Hood
137	532 40 75-90	Bumper, Dash	235	532 40 61-29	Spacer Fender
150	532 40 75-37	Air Duct	236	873 93-05-00	Nut Lock 5/16-18 unc Center
151	532 40 78-07	Bracket Pivot	238	532 41 11-19	Trim
152	532 19 95-35	Shield Browning	239	532 40 48-83	Clip Tinnerman
159	817 00 06-12	Screw Hex Wsh Thdr 3/8-16 x 3/4	282	532 41 41-10	Clip Retainer
162	532 14 24-32	Screw	283	532 41 63-16	Console Deck Lift
175	532 19 94-72	Crossmember	284	532 41 78-87	Console Control Pedal
176	532 40 07-76	Screw 10-24 x 5/8	285	532 41 63-15	Console Insert RH
177	532 19 52-28	Bushing Steering	286	532 41 63-17	Console Insert LH
180	532 19 54-57	Chassis	287	817 60 04-06	Screw Hex Washhead 1/4-20 x 3/8
182	532 40 71-76	Dash Lower	297	532 40 66-65	Insert Reflective LH
183	874 52 05-20	Bolt 5/16-18 unc x 1-1/4	--	532 43 18-83	Kit Bumper
189	817 00 05-12	Screw 5/16-18 x 3/4			
191	532 41 65-01	Insert Reflective RH			
194	873 90 05-00	Nut Lock Hex Flange 5/16-18			

**NOTE:** All component dimensions given in U.S. inches  
1 inch = 25.4 mm

TRACTOR - - MODEL NO. LTH2142 (96041022300), PRODUCT NO. 960 41 02-23  
DRIVE **40**

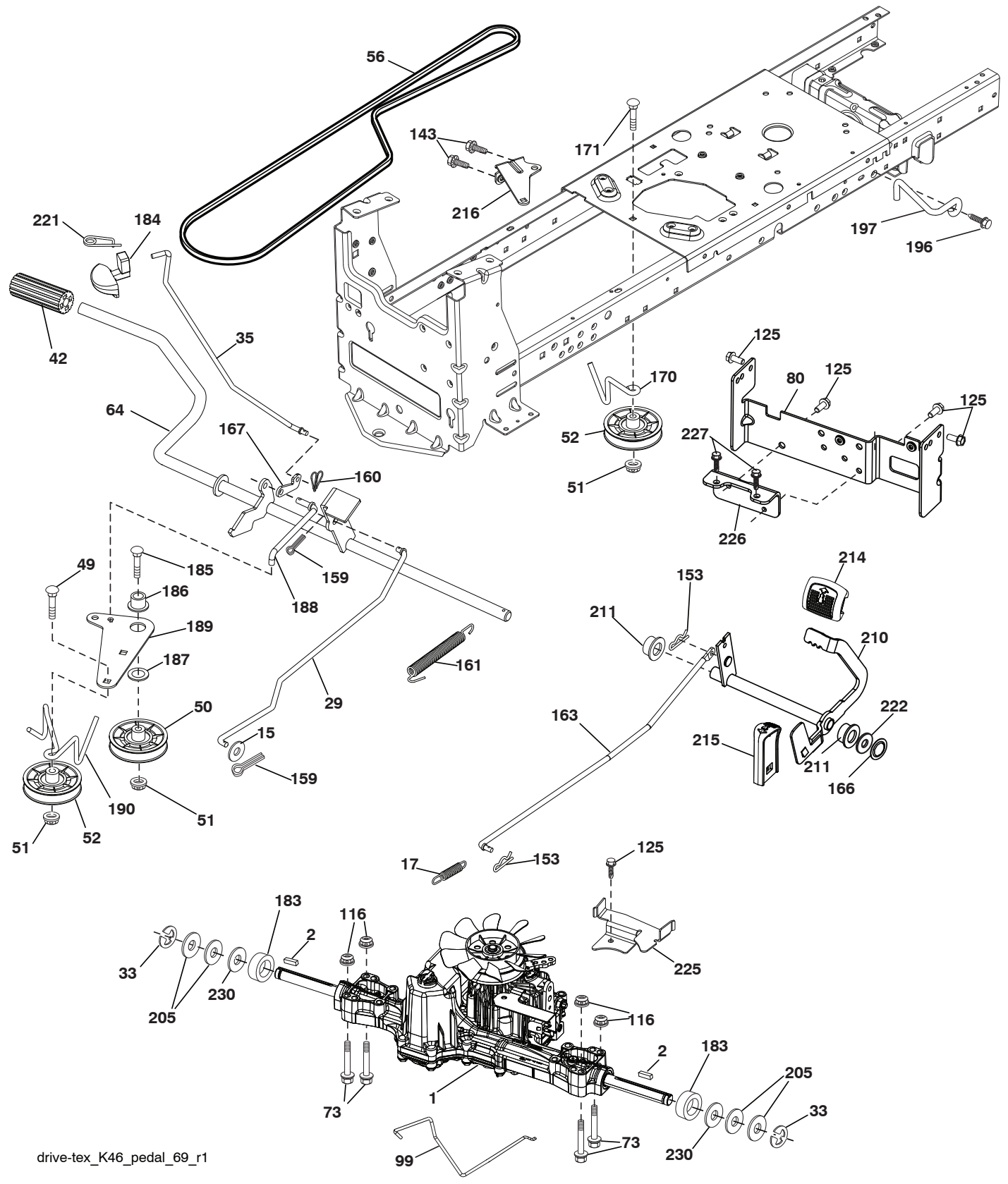

drive-tex\_K46\_pedal\_69\_r1



**TRACTOR - - MODEL NO. LTH2142 (96041022300), PRODUCT NO. 960 41 02-23  
DRIVE 40**

KEY NO.	PART NO.	DESCRIPTION
1	- - - - -	Transaxle, TUFFTORQ K46 BT (Order parts from transaxle manufacturer)
2	532 12 35-83	Key
15	819 13 13-16	Washer 13/32 x 13/16 x 16 Ga.
17	532 41 36-78	Spring, Brake
29	532 40 38-06	Rod, Brake
33	812 00 00-01	Ring E
35	532 40 10-31	Rod, Brake, Park
42	532 12 48-72	Cover, Foot Pedal
49	872 11 06-14	Bolt
50	532 19 43-27	Pulley Idler Flat
51	873 90 06-00	Lock Nut 3/8-16
52	532 19 43-26	Idler V-Groove 910" Offset
56	532 13 09-69	V-Belt, Drive
64	532 19 78-65	Shaft Asm. Pedal Brake Control
73	874 49 05-40	Bolt Hex Flghd 5/16-18 x 2-1/2 G5
80	532 44 06-19	Bracket Strap Torque
99	532 41 57-42	Rod Spring Bypass
116	873 90 05-00	Nut Lock Hex Flange 5/16-18
125	817 00 05-12	Screw 5/16-18 x 3/4
143	817 49 05-08	Screw 5/16-18 x 1/2
153	532 12 47-88	Retainer Spring
159	876 02 04-12	Pin Cotter 1/8 x 3/4
160	532 16 94-84	Retainer Clip
161	532 10 57-09	Spring, Return, Clutch
163	532 44 82-75	Rod Pedal Control
166	532 42 91-64	Nut Push
167	532 40 52-57	Latch Brake Parking
170	532 19 43-22	Keeper Belt Centerspan
171	872 11 06-16	Bolt RDHD SQNK 3/8-16 unc x 2
183	532 13 70-57	Spacer Split
184	532 40 97-47	Handle Parking Brake
185	872 11 06-22	Bolt RDHD 3/8-16 unc x 2-3/4 Gr. 5
186	532 19 43-21	Spacer Retainer
187	819 13 32-10	Washer
188	532 19 43-23	Link Clutch Ground Drive
189	532 19 43-17	Bellcrank Ground Drive
190	532 19 43-18	Keeper Bellcrank Ground Drive
196	817 00 06-16	Screw 3/8-16 x 1
197	532 19 58-04	Bracket Clutch Anti-Rotation
205	532 12 17-48	Washer
210	532 40 09-80	Rocker Asm. Pedal Control
211	532 12 01-83	Bearing Nylon
214	532 42 12-63	Pedal Forward
215	532 40 17-23	Pedal Reverse
216	532 19 61-31	Bracket Pulley Idler
221	532 40 31-87	Retainer Spring Clip Handle
222	879 21 20-10	Washer 21/32 x 1-1/4 x 10 Ga.
225	532 40 33-19	Keeper Belt Trans.
226	532 40 15-64	Bracket Mount Torque
227	817 49 05-12	Screw Thdrol 5/16-18 x 3/4
230	532 18 89-67	Washer Hardened

**NOTE:** All component dimensions given in U.S. inches  
1 inch = 25.4 mm

TRACTOR - - MODEL NO. LTH2142 (96041022300), PRODUCT NO. 960 41 02-23  
ENGINE **24**

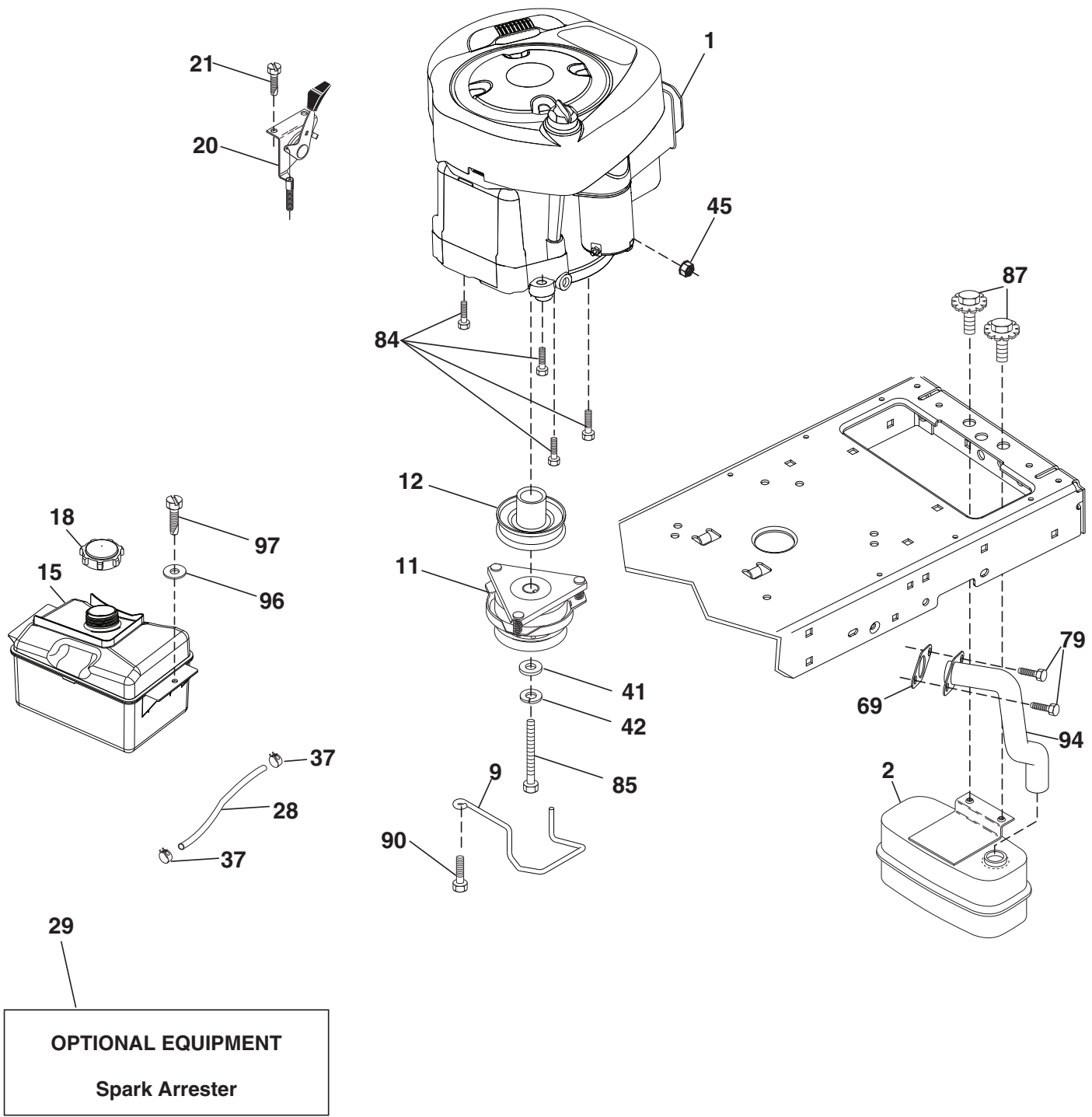

engine-tex\_BS\_44

**TRACTOR - - MODEL NO. LTH2142 (96041022300), PRODUCT NO. 960 41 02-23  
ENGINE 24**

KEY NO.	PART NO.	DESCRIPTION
1	- - - - -	Engine Briggs 33M777-2495-G1 (439011)(Order parts from engine manufacturer)
2	532 18 86-55	Muffler
9	532 19 43-20	Keeper Belt Engine
11	532 18 05-05	Clutch, Ogura
12	532 40 50-97	Pulley Engine
15	532 40 75-45	Tank Fuel 1.5
18	532 43 02-20	Cap Fuel
20	532 18 38-97	Control Throttle
21	532 41 63-58	Screw #10 x 0.750 BOS Thread
28	532 13 70-40	Fuel Line
29	532 13 71-80	Spark Arrester Kit
37	532 12 34-87	Clamp Hose
41	532 12 61-97	Washer 1-1/2 OD. x 15/32 ID x 250
42	810 04 07-00	Wahser Lock Hvy HLCL Spr. 7/16
45	873 51 04-00	Nut Keps Hex 1/4-20 unc
69	532 16 52-91	Gasket
79	532 19 23-34	Screw Socket HD. 5/16-18 x .75
84	817 06 06-20	Screw 3/8-16 x 1 1/4
85	532 17 39-37	Bolt Hex 7/16-20 x 4 x Gr. 5-1.5 Thr
87	532 17 18-77	Bolt 5/16-18 X 3/4
90	817 00 06-16	Screw 3/8-16 x 1
94	581 88 09-01	Tube Exhaust
96	819 09 14-16	Washer 9/32 x 7/8 x 16 Ga.
97	817 67 04-12	Screw 1/4-20 x 3/4

**NOTE:** All component dimensions given in U.S. inches  
1 inch = 25.4 mm

**Engine Power Rating Information**

The gross power rating for individual gas engine models is labeled in accordance with SAE (Society of Automotive Engineers) code J1940 (Small Engine Power & Torque Rating Procedure), and rating performance has been obtained and corrected in accordance with SAE J1995 (Revision 2002-05). Torque values are derived at 3060 RPM; horsepower values are derived at 3600 RPM. Actual gross engine power will be lower and is affected by, among other things, ambient operating conditions and engine-to-engine variability. Given both the wide array of products on which engines are placed and the variety of environmental issues applicable to operating the equipment, the gas engine will not develop the rated gross power when used in a given piece of power equipment (actual "on-site" or net power). This difference is due to a variety of factors including, but not limited to, accessories (air cleaner, exhaust, charging, cooling, carburetor, fuel pump, etc.), application limitations, ambient operating conditions (temperature, humidity, altitude), and engine-to-engine variability. Due to manufacturing and capacity limitations, Briggs & Stratton may substitute an engine of higher rated power for this Series engine.

TRACTOR - - MODEL NO. LTH2142 (96041022300), PRODUCT NO. 960 41 02-23  
STEERING ASSEMBLY **41**

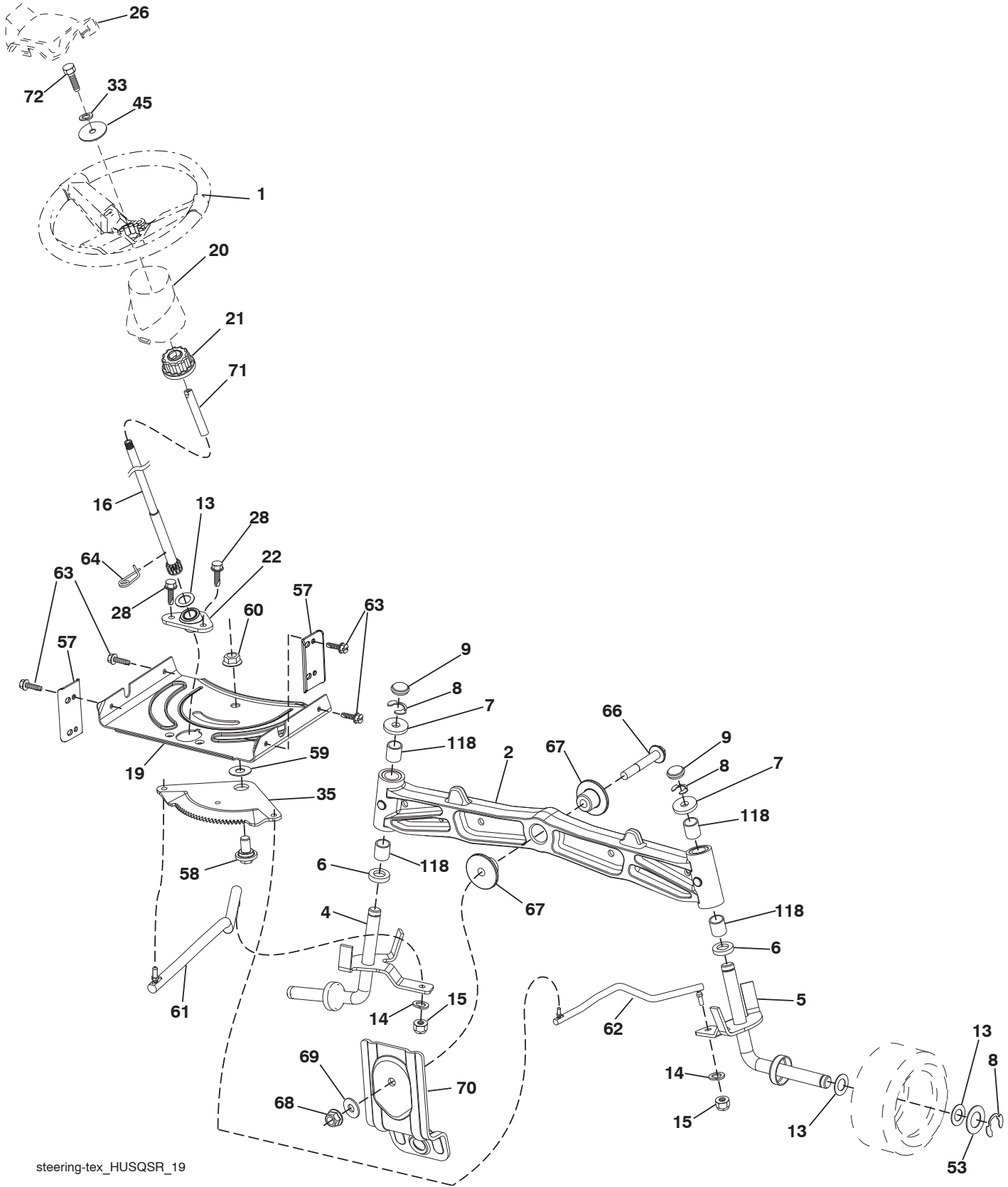

steering-tex\_HUSQSR\_19

**TRACTOR - - MODEL NO. LTH2142 (96041022300), PRODUCT NO. 960 41 02-23  
STEERING ASSEMBLY 41**

KEY NO.	PART NO.	DESCRIPTION
1	532 41 64-80	Wheel, Steering
2	532 41 35-91	Axle Asm., Front
4	532 40 30-87	Spindle Asm., LH
5	532 40 30-88	Spindle Asm., RH
6	532 12 49-31	Washer, Thrust
7	532 12 17-48	Washer 25/32 x 1-5/8 x 16 Ga.
8	812 00 00-29	Ring, Klip #T5304-75
9	532 12 12-32	Cap, Spindle
13	532 12 17-49	Washer 25/32 x 1-1/4 x 16 Ga.
14	810 04 06-00	Washer, Lock Hvy Hlcl Spr 3/8
15	873 54 06-00	Nut, Crown Lock 3/8-24 unf
16	532 42 93-73	Shaft Steering
19	532 19 47-29	Plate Steering
20	532 41 11-39	Boot, Steering
21	532 18 67-37	Adapter, Wheel Steering
22	532 42 05-37	Strg.
26	532 41 59-87	Insert, Wheel Steering
28	817 00 06-12	Screw 3/8-16 x 3/4
33	810 04 05-00	Washer Lock 5/16
35	532 19 47-32	Gear, Sector Plate
45	819 11 38-12	Washer 11/32 x 3/8 x 12 Ga.
53	532 18 89-67	WasherHardened .793x1.637x.060
57	532 40 74-65	Bracket Upstop
58	532 19 47-47	Bolt Shoulder Sector Pivot CFM
59	532 19 47-48	Washer Thrust Sector Steering
60	873 97 10-00	Nut Flange Lock 5/8-11
61	532 19 47-40	Draglink, LH
62	532 19 47-41	Draglink, RH
63	817 00 05-12	Screw 5/16-18 x 3/4
64	532 19 98-49	Retainer Clip Spring Steering
66	871 02 07-48	Bolt Hex Fghd 7/16-14 x 3 Serr
67	532 19 47-37	Bushing PM Front Axle
68	873 90 07-00	Nut Lock Flange 7/16-14 Gr. 5
69	532 19 91-62	Washer 1.5 x .505 x .118
70	532 19 61-97	Bracket Deck Susp. Front
71	532 19 07-52	Shaft Extension Steering
72	532 42 89-82	Bolt Fin Hex 5/16-18 x 4 w/Patch
118	532 40 60-13	Bushing

**NOTE:** All component dimensions given in U.S. inches  
1 inch = 25.4 mm

TRACTOR - - MODEL NO. LTH2142 (96041022300), PRODUCT NO. 960 41 02-23  
MOWER DECK 44

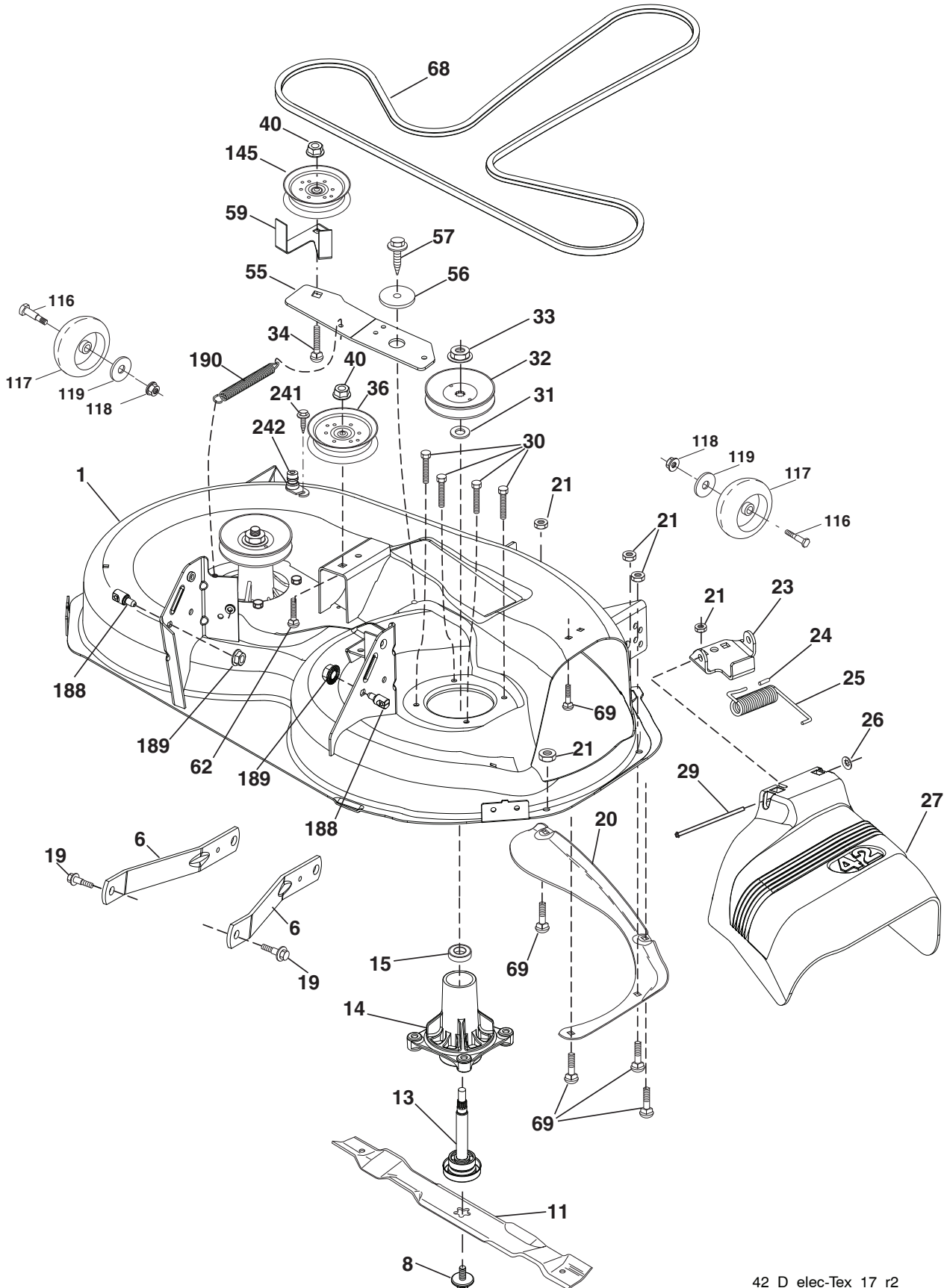

42\_D\_elec-Tex\_17\_r2

**TRACTOR - - MODEL NO. LTH2142 (96041022300), PRODUCT NO. 960 41 02-23  
MOWER DECK 44**

KEY NO.	PART NO.	DESCRIPTION
1	532 40 29-99	Mower Deck Assembly, 42"
6	532 19 51-86	Arm Susp. Rear
8	532 19 30-03	Bolt/Washer Asm 7/16-20 unf (The following Blades are available)
11	532 13 89-71	Blade Mower 42" Hi-Lift (for bagging and discharging)
13	532 19 28-72	Shaft Assembly, Mandrel
14	532 18 72-81	Housing, Mandrel
15	532 11 04-85	Bearing, Ball, Mandrel
19	532 19 65-39	Bolt, Shoulder
20	532 15 97-70	Baffle, Vortex
21	873 68 05-00	Nut
23	532 19 25-57	Bracket, Deflector Mower 42"
24	532 10 53-04	Cap, Sleeve 80 x 112 Blk Mower
25	532 19 70-26	Spring, Torsion, Deflector
26	532 11 04-52	Nut, Push Phos & Oil
27	532 40 30-04	Shield, Deflector 42" Blk
29	532 13 14-91	Rod, Hinge 42" 6 75 W/G
30	532 17 39-84	Screw Thdrol
31	532 18 76-90	Washer, Spacer Mower Vented
32	532 15 35-35	Pulley, Mandrel
33	532 40 02-34	Nut, Toplock
34	872 11 06-12	Bolt Carr SH 3/8-16 x 1-1/2 Gr. 5
36	532 19 73-79	Pulley Idler Flat
40	873 90 06-00	Nut Lock 3/8-16
55	532 43 71-10	Arm, Idler
56	532 19 90-92	Spacer, Retainer
57	817 00 06-16	Screw 3/8-16 x 1
59	532 14 10-43	Guard TUV Idler
62	872 11 06-16	Bolt Rdhd Sqnk 3/8-16 unc x 2
68	532 14 49-59	V-Belt, 42" Mower
69	872 14 05-05	Bolt, Carriage 5/16-18 x 5/8
116	532 12 48-42	Bolt, Shoulder
117	532 18 86-06	Wheel, Gauge
118	873 90 06-00	Nut Centerlock 3/8-16 unc
119	819 12 14-14	Washer 3/8 x 7/8 x 14
145	532 19 31-97	Pulley, Idler, Flat
188	532 19 51-61	Stud Fastner W/D Anti-Rotation
189	873 90 05-00	Nut Lock Hex Flange 5/16-18
190	532 19 72-51	Spring Mower Drive
241	532 15 29-27	Screw TT #10-32.5 3/8 Flange
242	532 41 55-98	Port Washout
--	532 19 28-70	Mandrel Assembly (Includes Housing Shaft and Shaft Hardware Only - Pulley Not Included)
--	532 40 12-24	Replacement Mower, Complete (Std. deck Order separately gauge wheel components Key Nos. 116-119)

**NOTE:** All component dimensions given in U.S. inches  
1 inch = 25.4 mm

**TRACTOR - - MODEL NO. LTH2142 (96041022300), PRODUCT NO. 960 41 02-23**  
**MOWER LIFT 45**

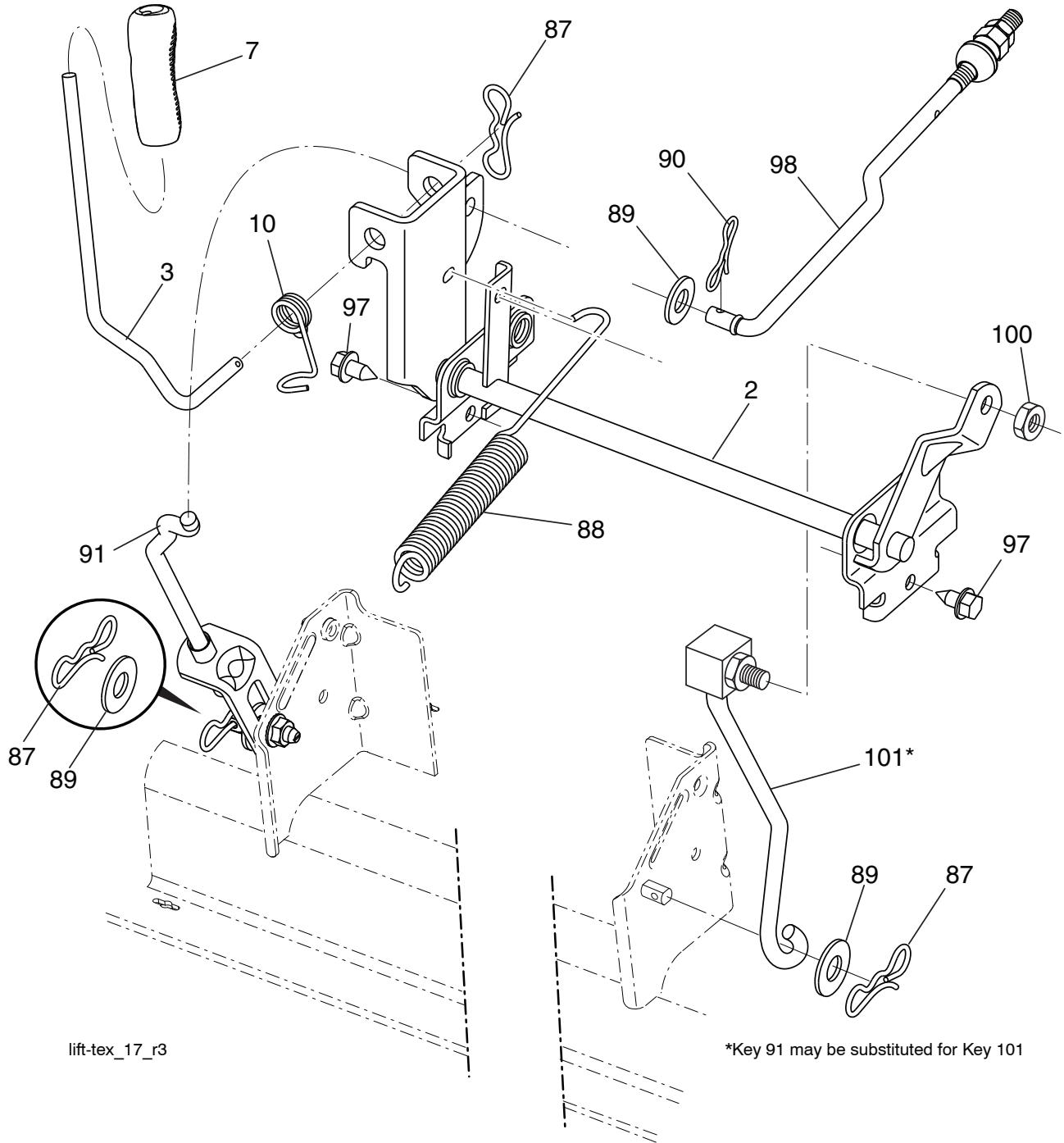

lift-tex\_17\_r3

\*Key 91 may be substituted for Key 101

KEY NO.	PART NO.	DESCRIPTION
2	532 42 20-27	Shaft Asm., Lift
3	532 19 52-31	Lever Asm., Lift RH
7	532 41 15-55	Grip, Lever
10	532 19 63-14	Spring Torsion
87	532 19 42-09	Pin Cotter 7/16 Bow Tie Lock
88	532 41 07-10	Spring Lift Assist
89	819 19 19-12	Washer Clear Zinc
90	532 19 42-08	Pin Cotter 5/16 Bow Tie Lock

KEY NO.	PART NO.	DESCRIPTION
91	532 19 51-81	Link Lift Susp Mower Rear
97	817 00 06-12	Screw Hex WSH THDR 3/8-16 x 3/4
98	532 19 52-70	Link Lift Susp. Front Mower
100	873 93 06-00	Nut Centerlock 3/8-16
101	532 40 70-03	Link Asm. Lift Fxd

**NOTE:** All component dimensions given in U.S. inches  
 1 inch = 25.4 mm



**TRACTOR - - MODEL NO. LTH2142 (96041022300), PRODUCT NO. 960 41 02-23  
SEAT ASSEMBLY 42**

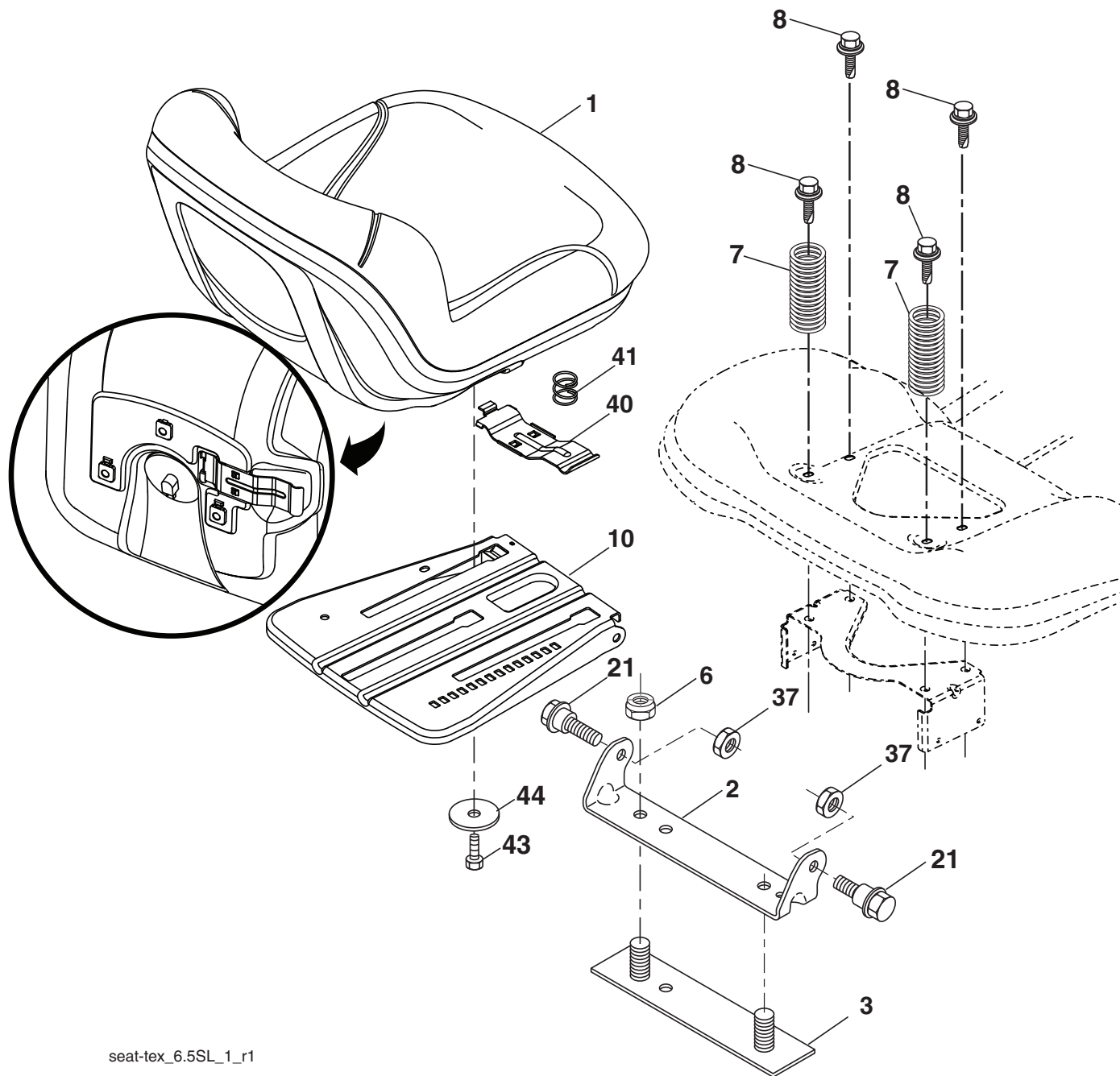

seat-tex\_6.5SL\_1\_r1

KEY NO.	PART NO.	DESCRIPTION
1	532 42 40-67	Seat
2	532 18 01-66	Bracket Pivot Fender
3	532 14 06-75	Strap, Asm Fender
6	873 80 06-00	Nut, Lock w/Ins. 3/8-16 unc
7	532 12 41-81	Spring, Seat Cprsn
8	532 17 18-77	Bolt 5/16-18 unc x 3/4 w/Sems
10	532 19 69-77	Pan, Seat
21	532 17 18-52	Bolt, Shoulder 5/16-18

KEY NO.	PART NO.	DESCRIPTION
37	873 80 05-00	Nut, Lock 5/16-18 unc
40	532 19 76-61	Handle Slide
41	532 19 82-00	Spring Latch Seat
43	874 76 06-12	Bolt Fin Hex 3/8-16 unc x 3/4
44	819 13 38-12	Washer 13/32 x 2-3/8 x 12 Ga.

**NOTE:** All component dimensions given in U.S. inches  
1 inch = 25.4 mm

