

ILLUSTRATED PARTS LIST

MFG. ID NO. 96041022600

CUSTOMER CATALOG NO. GTH263T

PRODUCT NO. 960 41 02-26

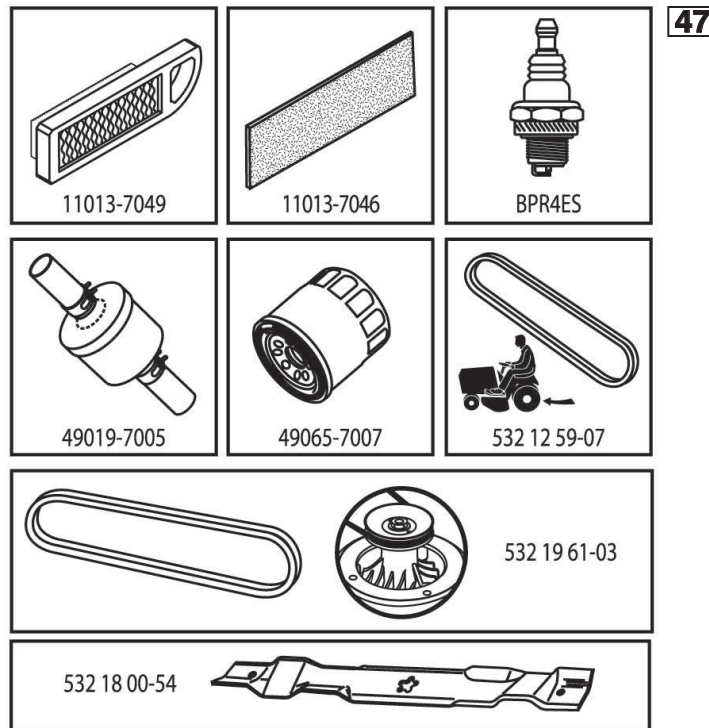

442503

**TRACTOR - - MODEL NO. GTH263T (96041022600), PRODUCT NO. 960 41 02-26
DECALS 27**

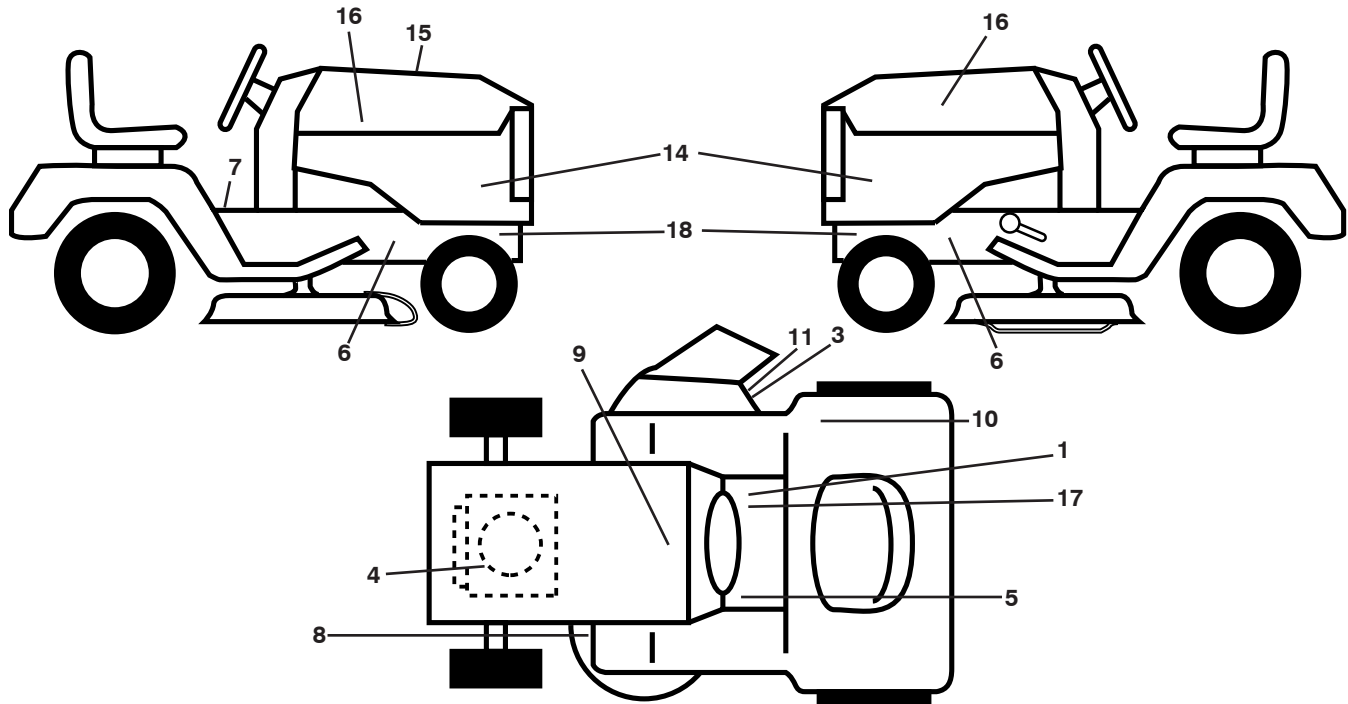

KEY NO.	PART NO.	DESCRIPTION
1	532 17 83-02	Decal, Drive Pedals
3	532 19 63-57	Decal, Warning
4	532 19 68-41	Decal, Engine Warning Symbols
5	532 15 97-37	Decal, Brake Pedal
6	532 40 11-46	Decal, Warning
7	532 40 03-89	Decal, Warning Symbols
8	532 19 87-85	Decal, Mower Sch.
9	532 14 50-05	Decal, Battery Dan./Poi.
10	532 18 04-33	Decal, Fender DB/CE
11	532 18 21-66	Decal, Hand/Foot Sym.

KEY NO.	PART NO.	DESCRIPTION
14	532 43 93-14	Decal, Panel Side
15	532 44 25-03	Decal, Replacement Parts
16	581 62 73-01	Decal, Hood Logo
17	532 14 08-37	Decal, Park Brake
18	532 15 97-36	Decal, Chassis Hot Muffler
--	532 16 25-98	Decal, Drawbar Load Limit
--	532 16 69-60	Decal, Bypass
--	532 43 98-82	Pad, Footrest, LH
--	532 43 98-81	Pad, Footrest, RH
--	532 44 25-98	Manual, Operator's (Euro)

WHEELS AND TIRES

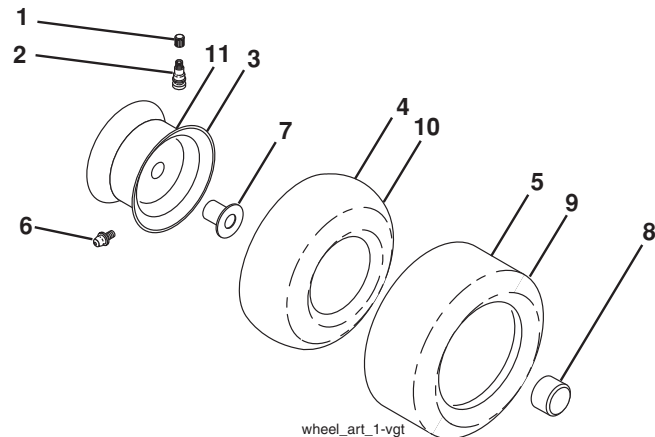

KEY NO.	PART NO.	DESCRIPTION
1	532 05 91-92	Cap, Valve, Tire
2	532 06 51-39	Stem, Valve
3	532 18 18-39	Rim Assembly, Front
4	532 00 81-34	Tube, Front (Service Item Only)
5	532 10 62-30	Tire, Front
6	532 12 49-57	Fitting, Grease (Front Wheel Only)
7	532 12 49-59	Bearing, Flange (Front Wheel Only)
8	532 17 50-39	Cap, Axle (Front Wheel Only)
9	532 10 55-88	Tire, Rear
10	532 00 71-54	Tube, Rear (Service Item Only)
11	532 14 45-10	Rim Assembly, Rear
--	532 14 43-34	Sealant, Tire (10 oz. Tube)

NOTE: All component dimensions given in U.S. inches
1 inch = 25.4 mm

TRACTOR - - MODEL NO. GTH263T (96041022600), PRODUCT NO. 960 41 02-26 SCHEMATIC 38

SCH12

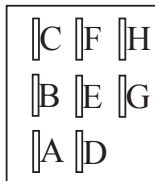
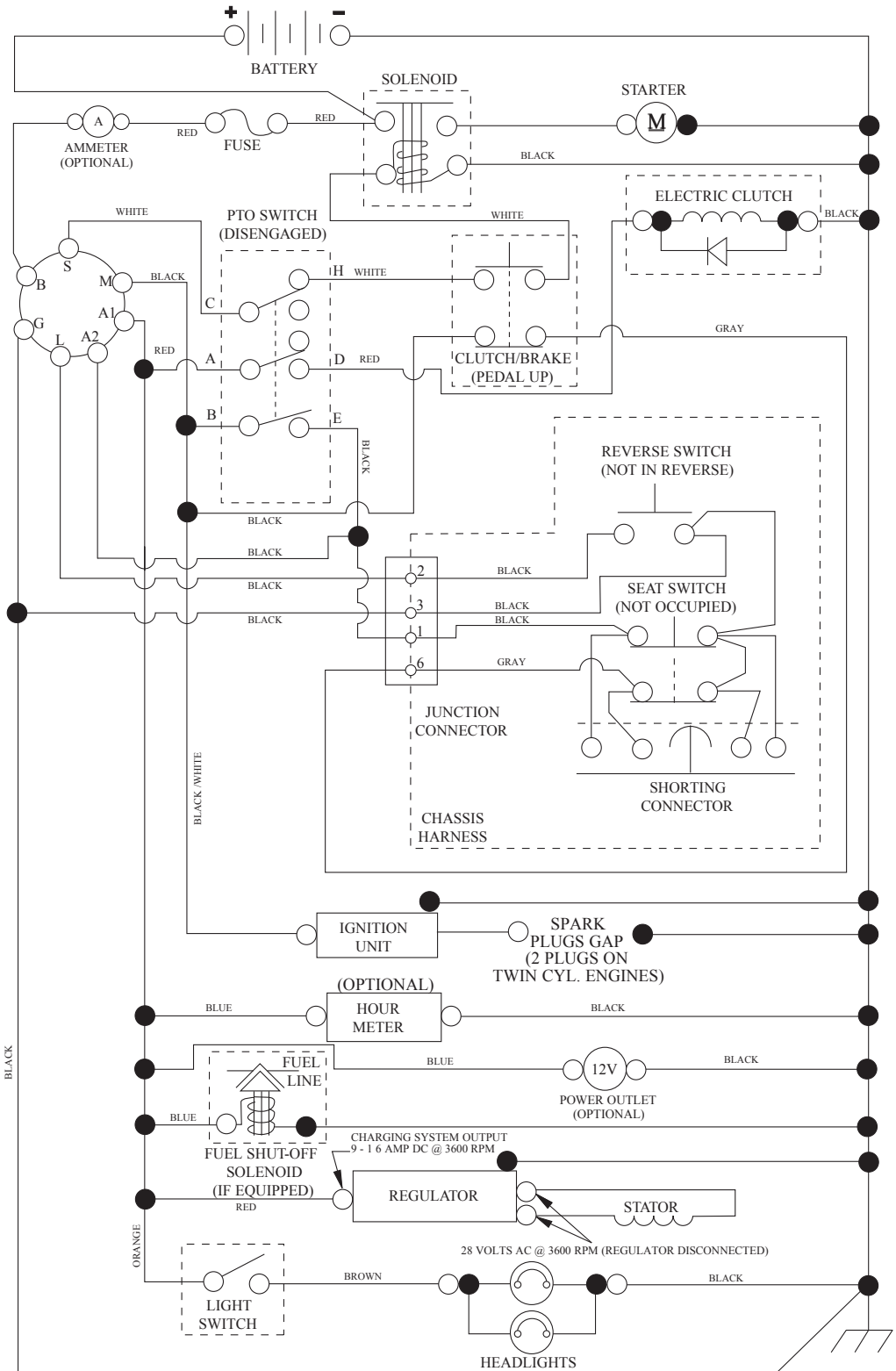

PTO SWITCH (MATING SIDE)

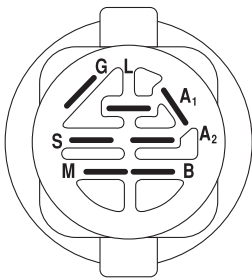

POSITION	CIRCUIT	"MAKE"
OFF	M+G+A1	
RUN/OVERRIDE	B+A1	
RUN	B+A1	L+A2
START	B + S + A1	

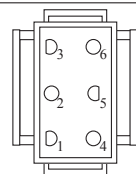

CHASSIS HARNESS CONNECTOR (MATING SIDE)

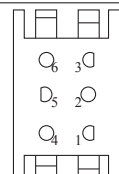

DASH HARNESS CONNECTOR

WIRING INSULATED CLIPS
NOTE: IF WIRING INSULATED CLIPS WERE REMOVED FOR SERVICING OF UNIT, THEY SHOULD BE RE-INSTALLED TO PROPERLY SECURE YOUR WIRING.

NON-REMOVABLE CONNECTIONS

REMOVABLE CONNECTIONS

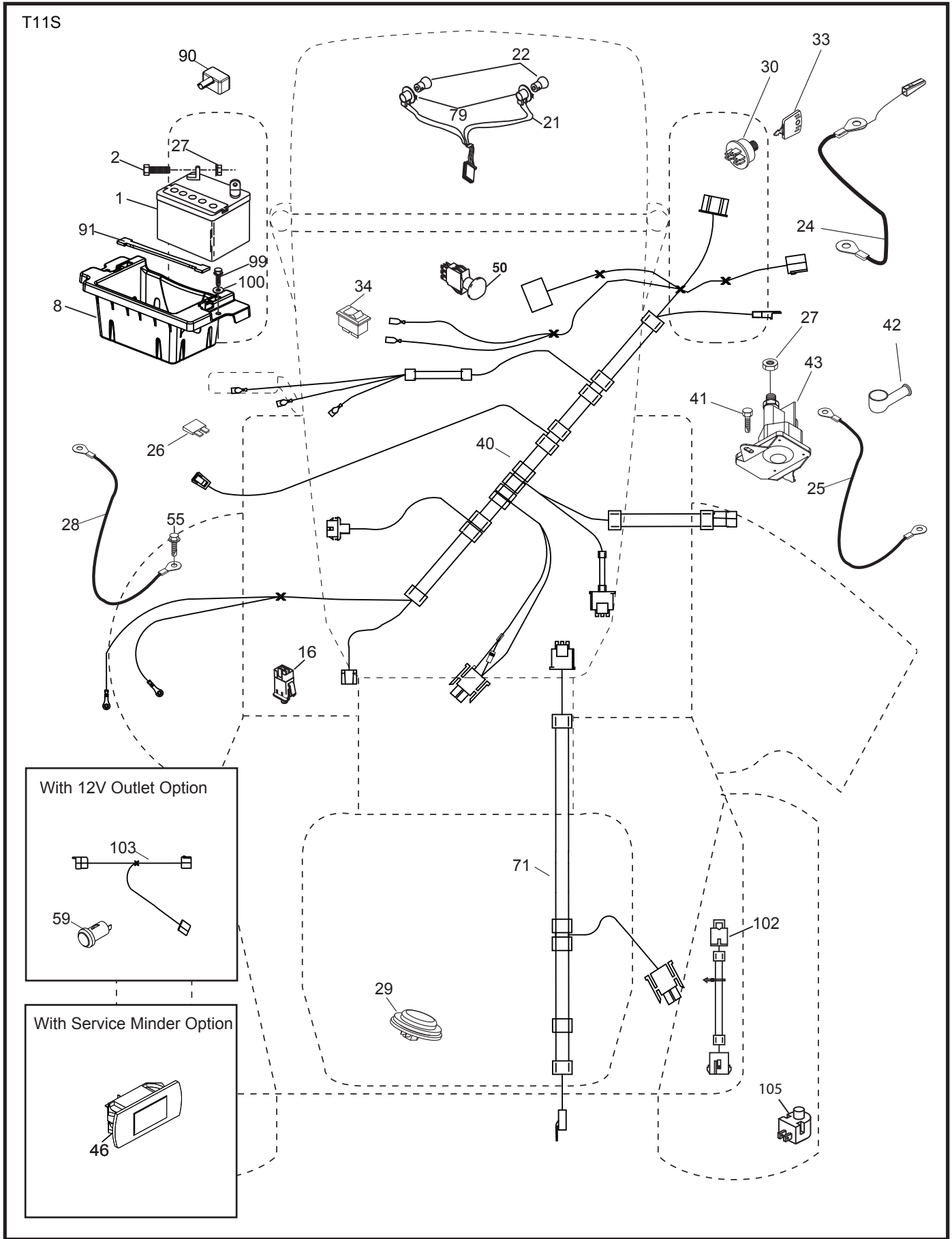

**TRACTOR - - MODEL NO. GTH263T (96041022600), PRODUCT NO. 960 41 02-26
ELECTRICAL 32**

KEY NO.	PART NO.	DESCRIPTION
1	532 16 34-65	Battery
2	874 76 04-12	Bolt Hex Hd. 1/4-20 unc x 3/4
8	532 18 64-91	Battery Box
16	532 17 61-38	Switch Interlock
21	532 40 02-52	Harness Socket Light
22	532 00 41-52	Bulb, Light # 1156
24	532 40 02-53	Cable Battery
25	532 41 28-95	Cable Start Red
26	532 17 51-58	Fuse
27	873 51 04 00	Nut Keps Hex 1/4-20 unc
28	532 14 54-91	Cable Ground 21" Blk. 6 Ga.
29	532 40 15-45	Switch Seat
30	532 19 33-50	Switch Ign.
33	532 41 19-35	Key/Chain
34	532 11 07-12	Switch Light/Reset
40	532 40 11-04	Harness Dash
41	817 72 04-08	Screw 1/4-20 x 1/2
42	532 13 15-63	Cover Terminal
43	532 19 25-07	Solenoid
46	532 40 17-63	Gauge Hourmeter
50	532 17 46-51	Switch PTO
55	817 06 05-12	Screw 5/16-18 x 3/4
71	532 19 42-76	Harness Chassis
79	532 17 52-42	Socket Asm. Bulb
90	532 43 53-95	Cover Terminal Battery
91	532 19 02-70	Strap Battery
99	817 67 04-12	Screw Hex Wsh. Thdrol. 1/4-20 x 3/4
100	819 09 14-16	Washer 9/32 x 7/8 x 16 Ga.
102	532 40 44-54	Harness Pigtail
105	532 40 75-68	Switch Reverse

NOTE: All component dimensions given in U.S. inches
1 inch = 25.4 mm

TRACTOR - - MODEL NO. GTH263T (96041022600), PRODUCT NO. 960 41 02-26
CHASSIS AND ENCLOSURES **39**

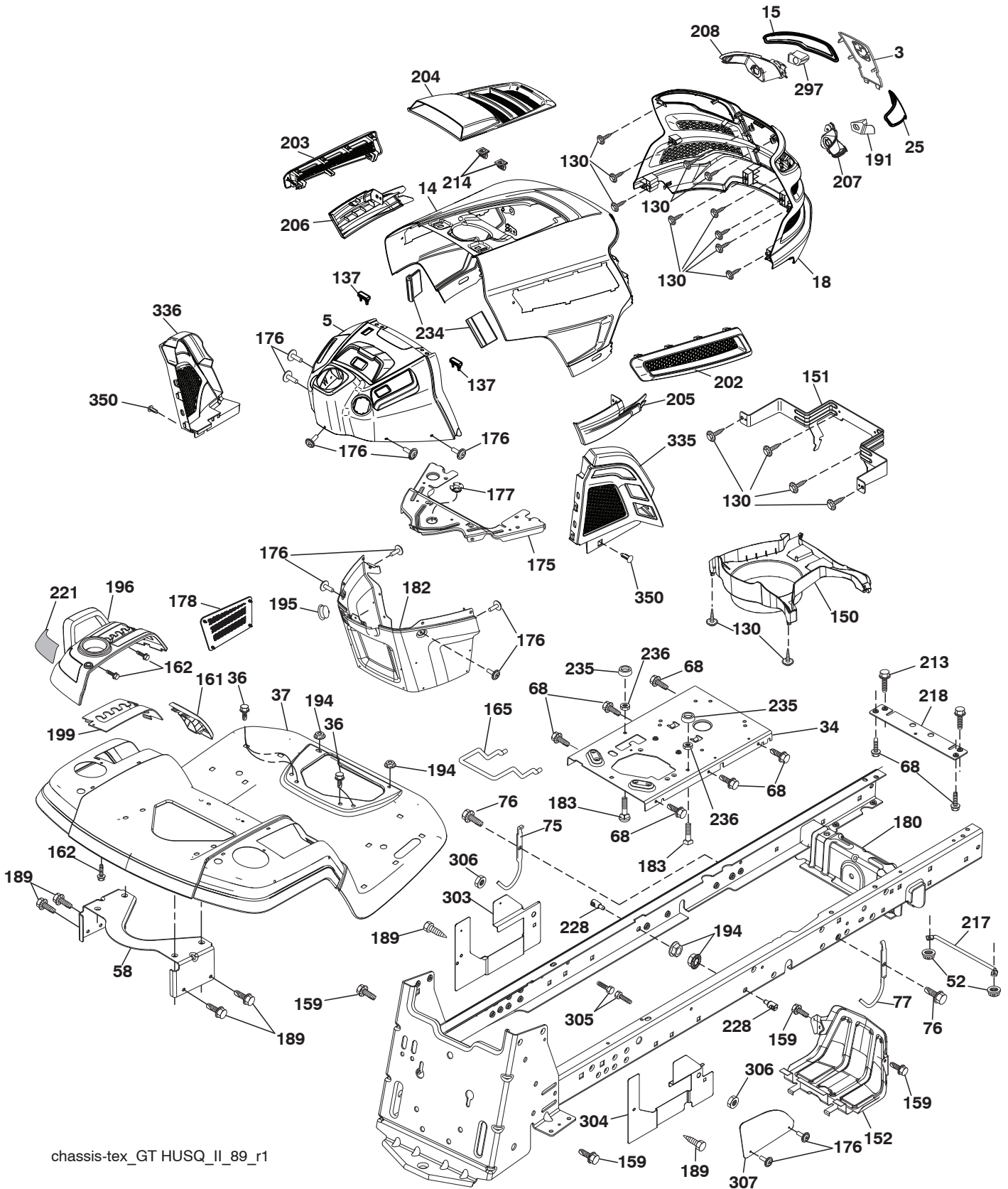

chassis-tex_GT HUSQ_II_89_r1

**TRACTOR - - MODEL NO. GTH263T (96041022600), PRODUCT NO. 960 41 02-26
CHASSIS AND ENCLOSURES 39**

KEY NO.	PART NO.	DESCRIPTION	KEY NO.	PART NO.	DESCRIPTION
3	532 43 97-52	Applique Sub Asm.	195	532 40 41-37	Plug 12 V Adapter
5	532 43 74-72	Dash	196	532 43 97-16	Console Asm. Deck Lift
14	532 44 11-77	Hood	199	532 19 82-59	Plate Deck Lift
15	532 43 97-33	Lens LH	202	532 43 97-28	Vent Side Hood RH
18	532 43 77-62	Grille	203	532 43 97-27	Vent Side Hood LH
25	532 44 33-85	Lens RH	204	532 43 57-14	Vent Asm. Hood Top
34	532 19 61-25	Plate Engine	205	532 43 97-30	Skirt Hood Side RH
36	817 06 05-12	Screw 5/16-18 x 3/4	206	532 43 97-29	Skirt Hood Side LH
37	532 44 12-08	Fender	207	532 43 97-34	Bezel RH
52	873 68 05-00	Nut Crownlock 5/16-18	208	532 43 97-35	Bezel LH
58	532 19 43-14	Bracket Fender	213	874 76 05-12	Bolt Hex Hd. 5/16-18 unc x 3/4
68	817 49 05-08	Screw 5/16-18 x 1/2	214	532 19 91-45	Clip Retainer
75	532 40 26-80	Rod Upstop LH	217	532 40 91-67	Rod Pivot
76	817 00 06-16	Screw 3/8-16 x 1	218	532 19 63-95	Hood Stop
77	532 40 26-81	Rod Upstop RH	221	532 19 89-09	Reflector LH
130	532 41 63-58	Screw #10 x 0.750	228	532 19 51-61	Stud Fastener
137	532 40 75 90	Bumper Dash	234	532 40 47 42	Bumper Hood
150	532 43 97-74	Duct Heat Hood	235	532 40 61 29	Spacer Fender
151	532 43 66-70	Pivot Bracket	236	873 93 05-00	Nut 5/16-18 unc
152	532 43 98-70	Shield Browning/Debris	297	532 43 74 56	Insert Reflective LH
159	817 00 06-12	Screw 3/8-16 x 3/4 BL	303	532 42 09-59	Shield Chassis Fren LH
161	532 43 99-29	Console Fuel Window	304	532 42 15-09	Shield Chassis Fren RH
162	532 14 24-32	Screw Hex Wsh. Hi-Lo 1/4 x 1/2	305	872 11 06-06	Bolt 3/8-16 x 3/4
165	532 19 68-26	Bracket Support Tank	306	739 00-60-00	Nut 3/8-16 unc
175	532 19 63-04	Crossmember	335	532 44 82-04	Lower Dash Cover RH
176	532 40 07-76	Screw #10-24 x 5/8	336	532 43 98-46	Lower Dash Cover LH
177	532 19 52-27	Bushing Steering	350	532 44 51-43	Clip X-mas Tree
178	532 19 97-82	Cargo Asm. Net	--	532 43 18-82	Kit Guard Brush
180	532 19 54-77	Chassis			
182	532 40 68-59	Dash Lower			
183	874 52 05-20	Bolt 5/16-18 unc x 1-1/4			
189	817 00 05-12	Screw 5/16-18 x 3/4			
191	532 43 74-55	Insert Reflective RH			
194	873 90 05-00	Nut Lock Hex Flange 5/16-18			

NOTE: All component dimensions given in U.S. inches
1 inch = 25.4 mm

TRACTOR - - MODEL NO. GTH263T (96041022600), PRODUCT NO. 960 41 02-26
 DRIVE **40**

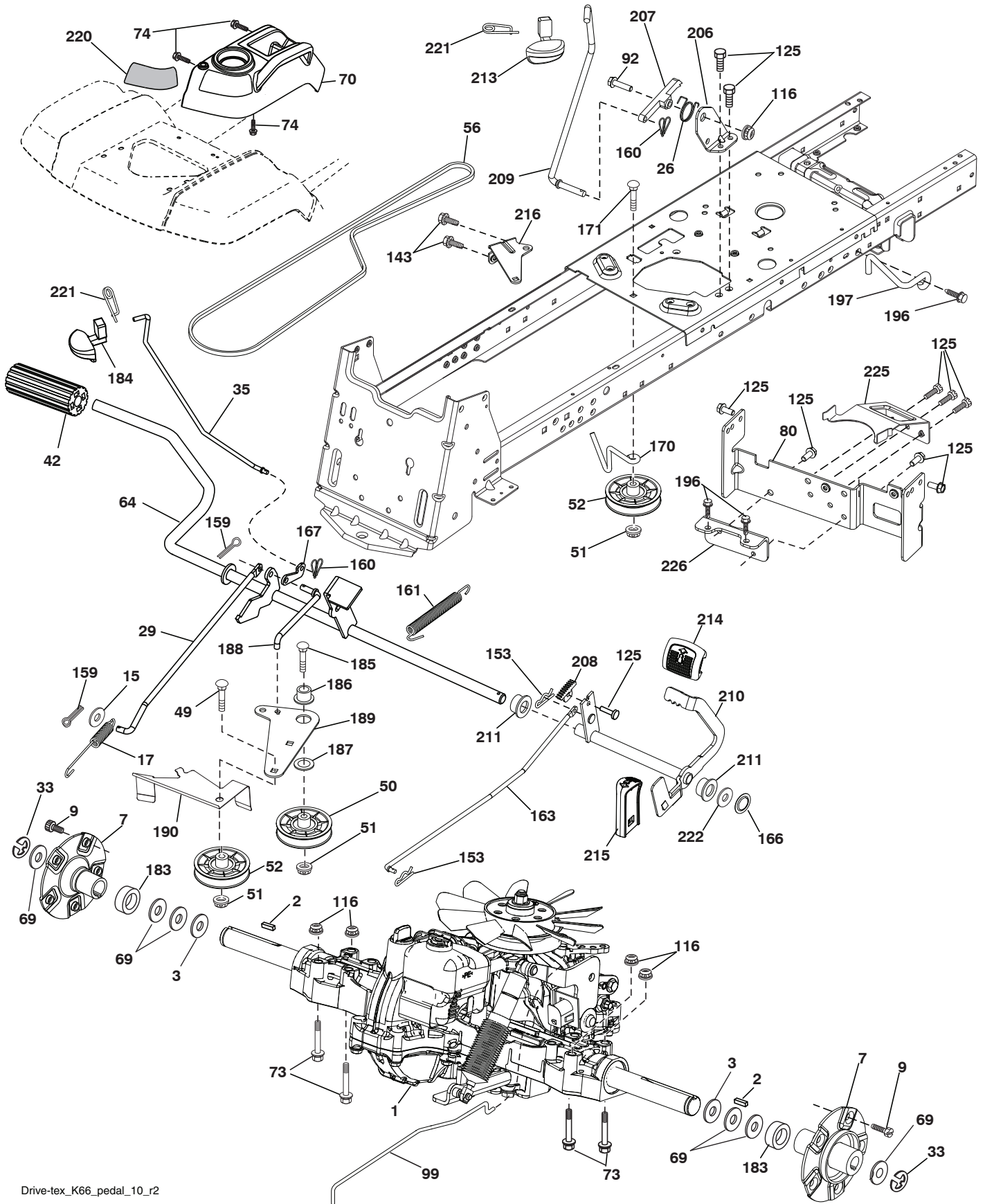

Drive-tex_K66_pedal_10_r2

**TRACTOR - - MODEL NO. GTH263T (96041022600), PRODUCT NO. 960 41 02-26
DRIVE 40**

KEY NO.	PART NO.	DESCRIPTION	KEY NO.	PART NO.	DESCRIPTION
1	-----	Transaxle, TuffTorq K66 Y (426118) (Order parts from transaxle manufacturer)	163	532 40 72-46	Rod Pedal Control
2	532 00 70-70	Key	166	532 42 91-64	Nut Push .625
3	532 00 75-63	Hardened Washer	167	532 40 52-57	Latch Brake Parking
7	532 19 98-37	Hub Asm. Wheel	170	532 19 43-22	Keeper Belt Centerspan
9	532 14 00-80	Bolt Hub Wheel	171	872 11 06-16	Bolt
15	819 13 13-16	Washer 13/32 x 13/16 x 16 Ga.	183	532 19 73-57	Spacer Axle
17	532 40 10-72	Spring, Brake	184	532 44 14-55	Handle Parking Brake
26	532 19 96-79	Spring Return Cruise	185	872 11 06-22	Bolt
29	532 40 72-45	Rod, Brake	186	532 19 43-21	Spacer Retainer
33	812 00 00-53	Ring E	187	819 13 32-10	Washer
35	583 86 45-01	Rod, Brake, Park	188	532 19 43-23	Link Clutch Ground Drive
42	532 12 48-72	Cover, Foot Pedal	189	532 19 43-17	Bellcrank Ground Drive
49	872 11 06-14	Bolt	190	532 19 43-18	Keeper Bellcrank Ground Drive
50	532 19 43-27	Pulley Idler Flat	196	817 00 06-16	Screw 3/8-16 x 1
51	873 90 06-00	Lock Nut 3/8-16	197	532 19 97-69	Bracket Clutch Anti-Rotation
52	532 19 43-26	Idler V-Groove 910" Offset	206	532 19 78-67	Bracket Mount Latch Cruise
56	532 12 59-07	V-Belt, Drive	207	532 19 78-68	Latch Control Cruise
64	532 19 78-65	Shaft Asm. Pedal Brake Control	208	532 19 78-69	Gear Sector Control Cruise
69	532 12 38-00	Washer 1 1/32 x 1 5/8 x 16 Ga.	209	532 19 95-92	Rod Control Cruise
70	532 43 96-61	Console Asm.	210	532 19 78-60	Rocker Asm Cruise
73	874 49 05-44	Bolt Hex Flghd 5/16-18 Gr. 5	211	532 12 01-83	Bearing Nylon
74	532 14 24-32	Screw Hx Wsh Hi-Lo 1/4 x 1/2 unc	213	532 40 31-19	Handle Parking Brake
80	532 40 71-82	Strap Torque	214	532 42 12-63	Pedal Forward Pad
92	874 76 05-20	Bolt Fin Hex 5/16-18 unc x 1.25	215	532 40 17-23	Pedal Reverse Pad
99	532 41 57-44	Rod Bypass	216	532 19 61-31	Bracket Pulley Idler
116	873 90 05-00	Nut Lock Hex Flange 5/16-18	220	532 19 89-08	Reflector RH
125	817 00 05-12	Screw 5/16-18 x 3/4	221	532 40 31-87	Retainer Spring Clip Handle
143	817 49 05-08	Screw 5/16-18 x 1/2	222	879 21 20-10	Washer 21/32 x 1-1/4 10 Ga.
153	532 12 47-88	Retainer Spring	225	532 40 73-11	Keeper Belt Trans.
159	876 02 04-12	Pin Cotter 1/8 x 3/4	226	532 40 71-09	Bracket Mount Torque
160	532 16 94-84	Retainer Clip			
161	532 10 57-09	Spring, Return, Clutch			

NOTE: All component dimensions given in U.S. inches
1 inch = 25.4 mm

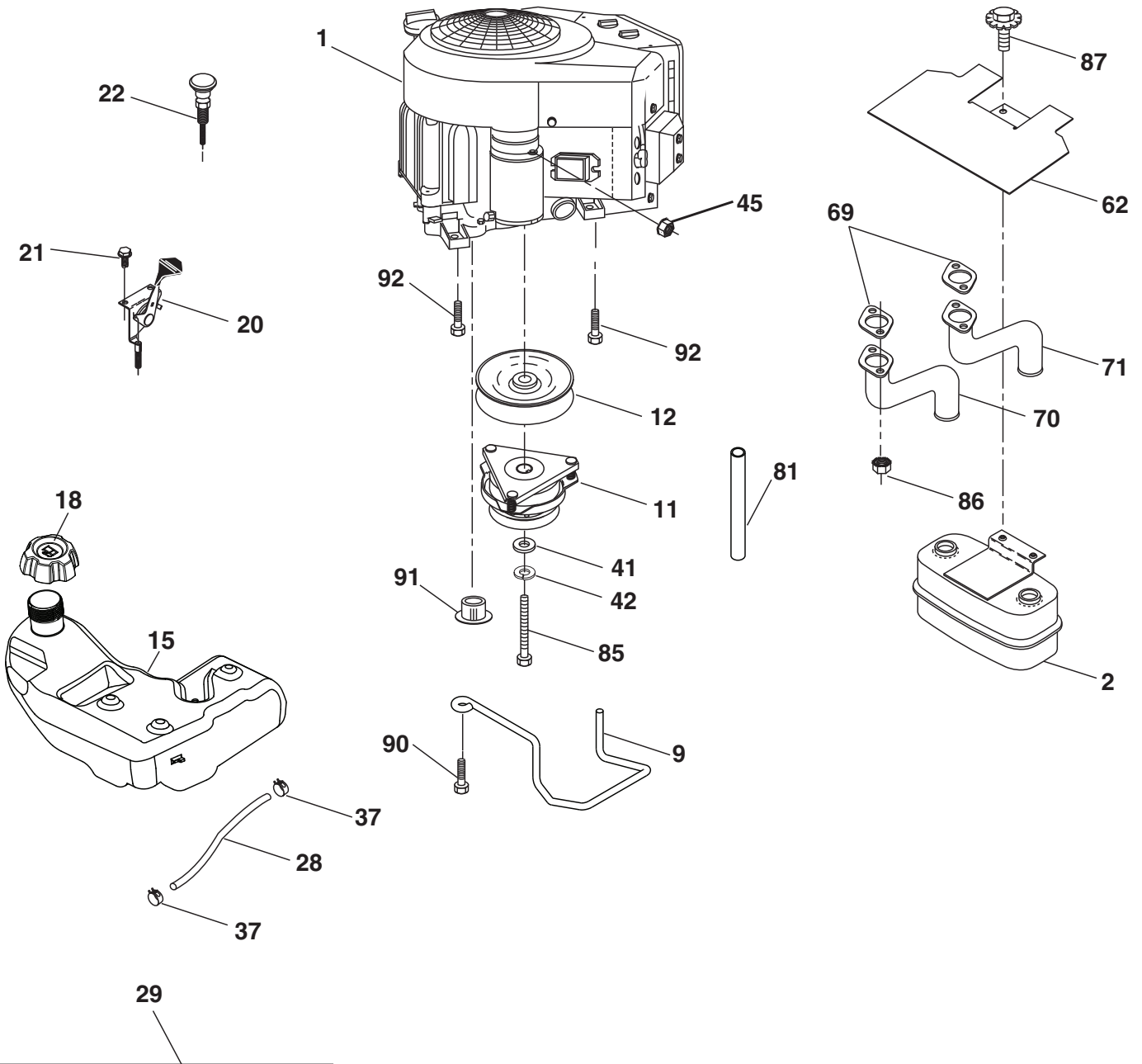

SPARK ARRESTER KIT

engine-tex_Kawa-2cyl_16

**TRACTOR - - MODEL NO. GTH263T (96041022600), PRODUCT NO. 960 41 02-26
ENGINE 24**

KEY NO.	PART NO.	DESCRIPTION
1	-----	Kawasaki FS730V-AS50 (437952) (Order parts from engine manufacturer)
2	532 14 97-23	Muffler
9	532 19 43-20	Keeper Belt Engine
11	532 17 93-35	Clutch Electric
12	532 19 43-43	Pulley Engine
15	532 19 34-99	Tank Fuel 4.0
18	532 43 96-45	Cap Fuel
20	532 18 29-37	Control Throttle
21	532 41 63-58	Screw #10 x 0.750
22	532 19 15-96	Control Choke
28	532 14 21-58	Fuel Line
29	532 13 71-80	Spark Arrester Kit
37	532 12 34-87	Clamp Hose
41	532 12 61-97	Washer 1-1/2 OD x 15/32 ID x .250
42	810 04 07-00	Washer Lock 7/16
45	873 51 04-00	Nut Keps 1/4-20 unc
62	532 43 40-17	Shield Heat Muffler
69	532 17 81-51	Gasket
70	532 42 47-65	Tube Exhaust LH
71	532 42 47-66	Tube Exhaust RH
81	532 14 84-56	Tube Drain Oil Easy
85	532 17 99-53	Bolt Hex 7/16-20 x 3.75 Gr. 5
86	532 18 43-62	Nut
87	532 19 82-39	Bolt 5/16-18 unc x 1 w/Sems.
90	817 00 06-16	Screw 3/8-16 x 1
91	532 18 74-95	Bushing
92	817 12 06-16	Screw 3/8-16 x 1

NOTE: All component dimensions given in U.S. inches
1 inch = 25.4 mm

TRACTOR - - MODEL NO. GTH263T (96041022600), PRODUCT NO. 960 41 02-26
STEERING ASSEMBLY **41**

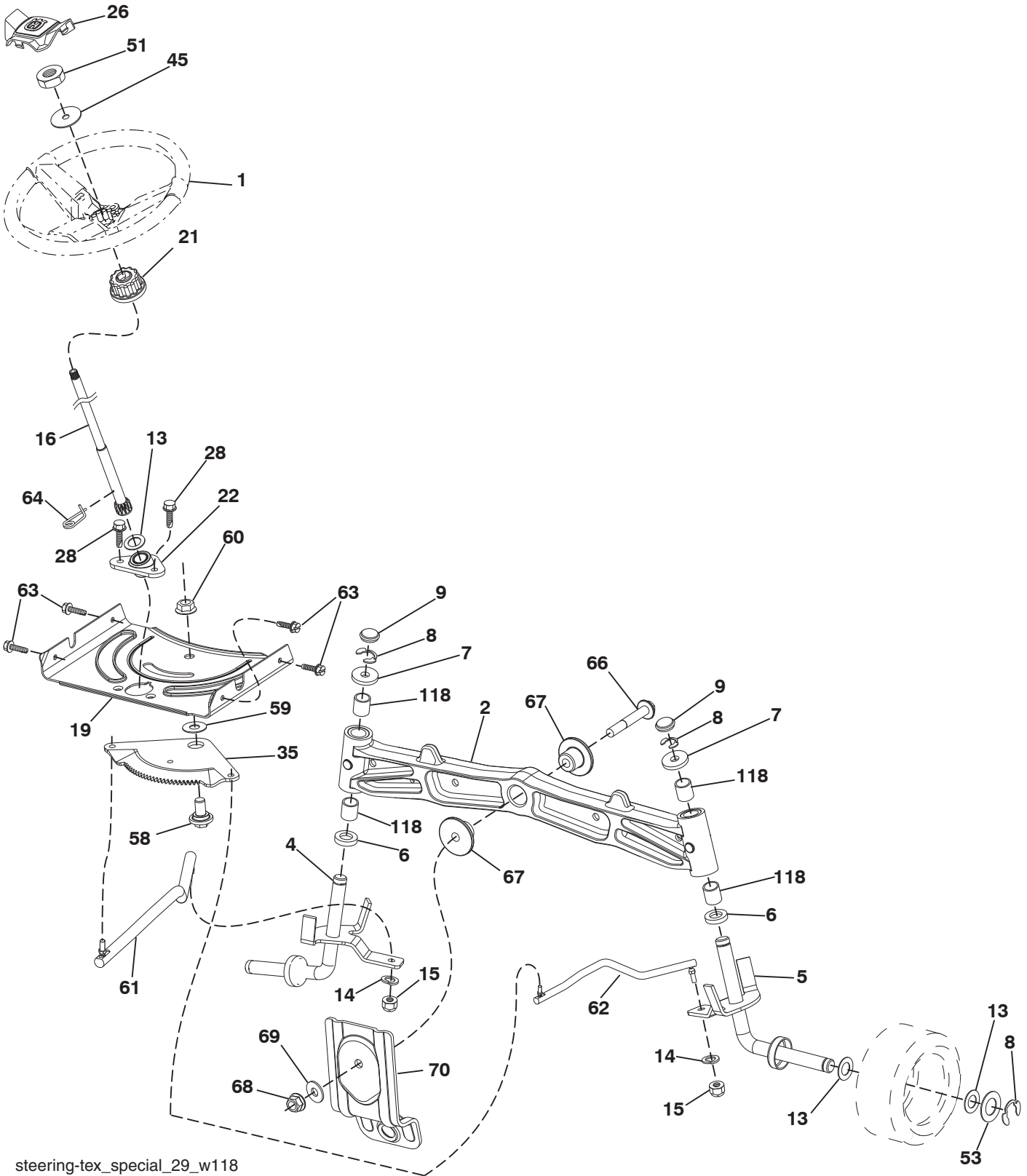

steering-tex_special_29_w118

**TRACTOR - - MODEL NO. GTH263T (96041022600), PRODUCT NO. 960 41 02-26
STEERING ASSEMBLY 41**

KEY NO.	PART NO.	DESCRIPTION
1	532 43 97-40	Wheel, Steering Husq SR
2	532 19 59-68	Axle Asm., Front
4	532 40 31-72	Spindle Asm., LH
5	532 40 31-73	Spindle Asm., RH
6	532 12 49-31	Bearing, Race Thrust Harden
7	532 12 17-48	Washer 25/32 x 1-5/8 x 16 Ga.
8	812 00 00-29	Ring, Clip #T5304-75
9	532 12 12-32	Cap, Spindle
13	532 12 17-49	Washer 25/32 x 1-1/4 x 16 Ga.
14	810 04 06-00	Washer, Lock Hvy. Hlcl. Spr. 3/8
15	873 54 06-00	Nut, Crown Lock 3/8-24 unf
16	532 19 47-46	Shaft Steering
19	532 19 47-29	Plate Steering
21	532 18 67-37	Adapter, Wheel Steering
22	532 42 05-37	Strg. Supt. Lower
26	532 43 97-43	Insert, Wheel Steering Husq SR
28	817 00 06-12	Screw 3/8-16 x 3/4
35	532 19 47-32	Gear, Sector Plate
45	819 18 38-12	Washer 9/16 x 2-3/8 x 12 Ga.
51	873 94 08-00	Nut Hex Jam Toplock 1/2-20 unf
53	532 18 89-67	WasherHardened.793x1.637x.060
58	532 19 47-47	Bolt Shoulder Sector Pivot CFM
59	532 19 47-48	Washer Thrust Sector Steering
60	873 97 10-00	Nut Flange Lock 5/8-11
61	532 19 47-40	Draglink, LH
62	532 19 47-41	Draglink, RH
63	817 00 05-12	Screw 5/16-18 x 3/4
64	532 19 98-49	Retainer Clip Spring Steering
66	871 02 07-48	Bolt Hex Fghd. 7/16-14 x 3 Serr.
67	532 19 47-37	Bushing PM Front Axle
68	873 90 07-00	Nut Lock Flange 7/16-14 Gr. 5
69	532 19 91-62	Washer 1.5 x .505 x .118
70	532 19 61-97	Bracket Deck Susp. Front
118	532 40 60-13	Bushing

NOTE: All component dimensions given in U.S. inches
1 inch = 25.4 mm

TRACTOR - - MODEL NO. GTH263T (96041022600), PRODUCT NO. 960 41 02-26
MOWER DECK **44**

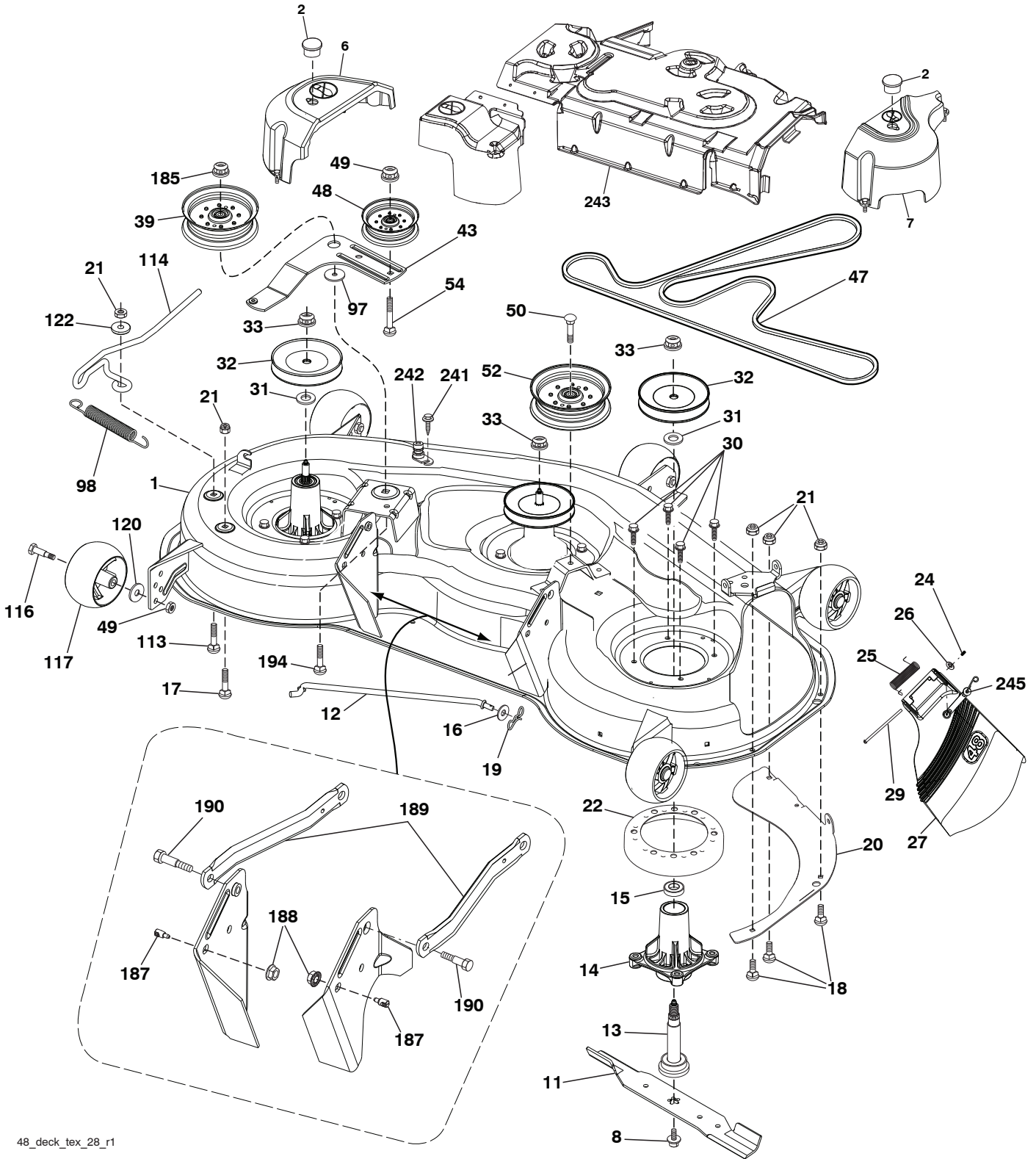

48_deck_tex_28_r1

**TRACTOR - - MODEL NO. GTH263T (96041022600), PRODUCT NO. 960 41 02-26
MOWER DECK 44**

KEY NO.	PART NO.	DESCRIPTION	KEY NO.	PART NO.	DESCRIPTION
1	532 40 42-65	Deck Weldment Mower	50	817 49 06-36	Screw TT 3/8-16 x 2-1/4
2	532 17 83-45	Plug Hole Mandrel	52	532 19 73-79	Pulley Idler Clutching
6	532 43 49-57	Cover Mandrel LH	54	872 11 06-12	Bolt Carr. Sh 3/8-16 x 1-1/2 Gr. 5
7	532 43 49-56	Cover Mandrel RH	97	532 17 85-15	Washer Hardened
8	532 19 30-03	Blot/Washer Asm 7/16-20 unf	98	532 19 61-05	Spring Drive
11	532 18 00-54	Blade High Lift	113	872 11 05-08	Bolt Rdhd Sqnk 5/16-18 x 3/4
12	532 40 03-37	Rod Anti-Sway	114	532 19 74-51	Rod Tension Relief
13	532 18 72-91	Shaft Asm. w/Lower Bearing	116	532 19 34-06	Bolt, Shoulder
14	532 18 72-81	Housing, Mandrel	117	532 17 48-73	Gauge Wheel
15	532 11 04-85	Bearing, Ball, Mandrel	120	819 13 20-12	Washer 13/32 x 1-1/4 x 12 Ga.
16	819 13 13-12	Washer 13/32 x 13/16 x 12 Ga.	122	532 18 75-57	Bushing Tension Relief
17	872 11 05-05	Bolt 5/16-18 x 5/8	185	873 90 07-00	Nut Lock Flange 7/16-14 Gr. 5
18	872 14 05-05	Bolt RdHd 5/16-18 unc x 5/8	187	532 19 51-61	Stud Fastener w/"D" Anti-Rotation
19	532 19 42-08	Pin Cotter 5/16 Bow Tie Lock	188	873 90 05-00	Nut Lock Hex Flange
20	532 17 43-78	Baffle Vortex	189	532 19 51-85	Arm Susp. Mower Rear
21	873 68 05-00	Nut, Crownlock 5/16-18 unc	190	532 19 65-39	Bolt Shoulder
22	532 17 44-93	Stripper Mandrel	194	874 49 07-36	Bolt Carr Sqnk 7/16-24 x 2
24	532 10 53-04	Cap Sleeve	241	532 15 29-27	Screw TT #10-32.5.3/8 Flange
25	532 17 81-02	Spring, Torsion	242	532 41 55-98	Port Washout
26	532 11 04-52	Nut, Push	243	532 43 52-19	Cover Asm Deck 48"
27	532 41 18-61	Deflector Shield	245	532 43 60-87	Kit Bungee (Includes Phillips head screw, weld nut, screw, bungee latch, and bungee strap)
29	532 13 14-91	Rod, Hinge			
30	532 17 39-84	Screw, Thdroll Washer Head			
31	532 18 76-90	Washer, Spacer Mower Vented	- - -	532 18 72-92	Mandrel Assembly (Includes housing, shaft assembly, and bearing only - pulley/nut/washer and blade bolt/washers not included)
32	532 15 35-32	Pulley, Mandrel			
33	532 40 02-34	Nut, Flg. Top Lock			
39	532 19 73-80	Pulley, Idler			
43	532 19 60-65	Arm, Idler	- - -	532 44 29-49	Replacement Mower, Complete
47	532 19 72-42	Belt Deck Drive			
48	532 19 31-97	Pulley Idler			
49	873 90 06-00	Nut, Lock Flg. 3/8-16 unc			

NOTE: All component dimensions given in U.S. inches
1 inch = 25.4 mm

TRACTOR - - MODEL NO. GTH263T (96041022600), PRODUCT NO. 960 41 02-26
 MOWER LIFT **45**

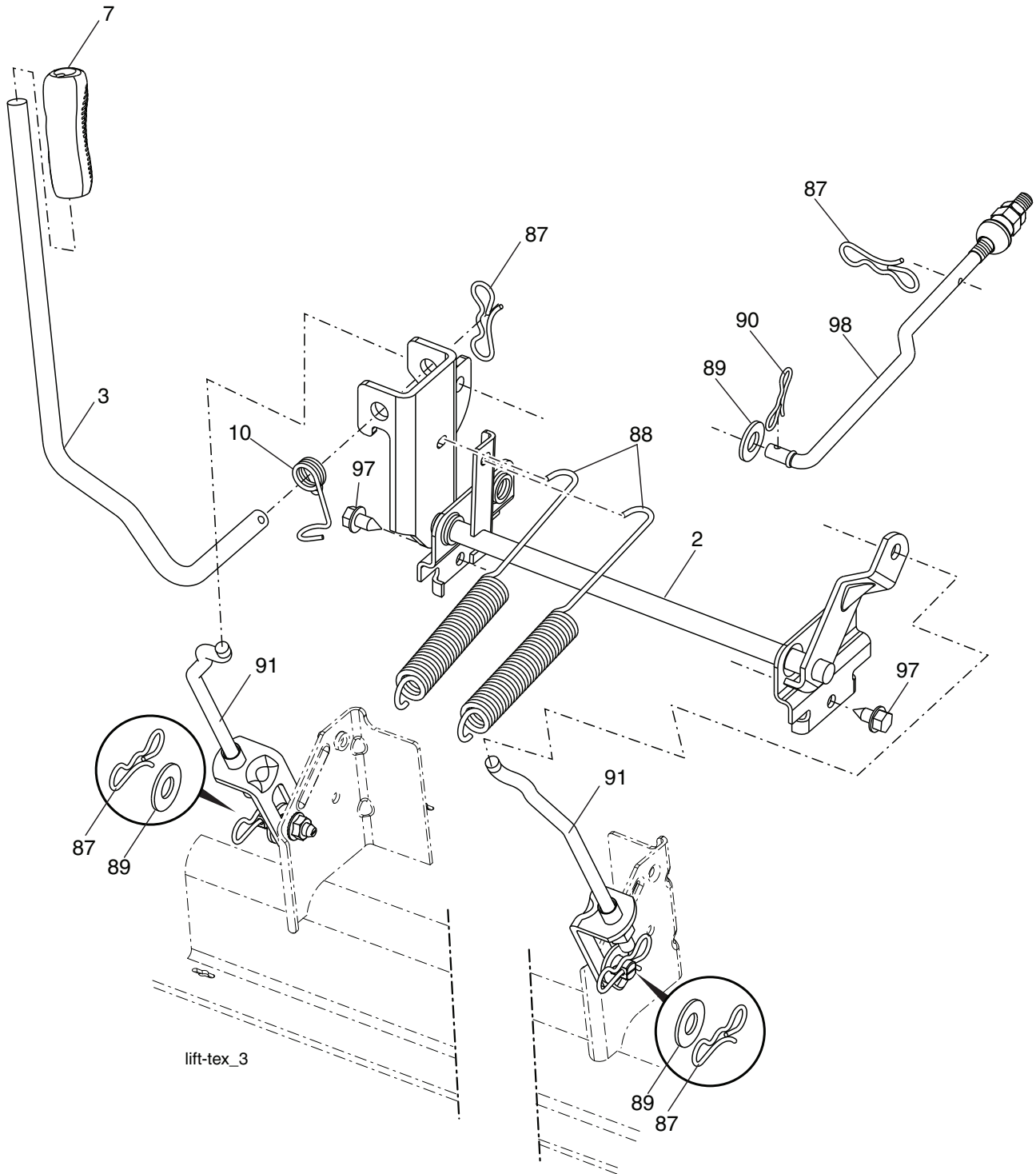

KEY NO.	PART NO.	DESCRIPTION
2	532 42 20-27	Shaft Asm., Lift
3	532 19 52-30	Lever Asm., Lift RH
7	532 41 15-55	Grip, Lever
10	532 19 63-14	Spring Torsion
87	532 19 42-09	Pin Cotter 7/16 Bow Tie Lock
88	532 19 53-04	Spring Lift Assist
89	819 19 19-12	Washer Clear Zinc

KEY NO.	PART NO.	DESCRIPTION
90	532 19 42-08	Pin Cotter 5/16 Bow Tie Lock
91	532 19 79-84	Lift Link Asm. Rear
97	817 00 06-12	Screw 3/8-16 x .75 Smgml. Tap/R.Z
98	532 19 52-64	Link Asm. Susp. Front Mower

NOTE: All component dimensions given in U.S. inches
 1 inch = 25.4 mm

**TRACTOR - - MODEL NO. GTH263T (96041022600), PRODUCT NO. 960 41 02-26
SEAT ASSEMBLY 42**

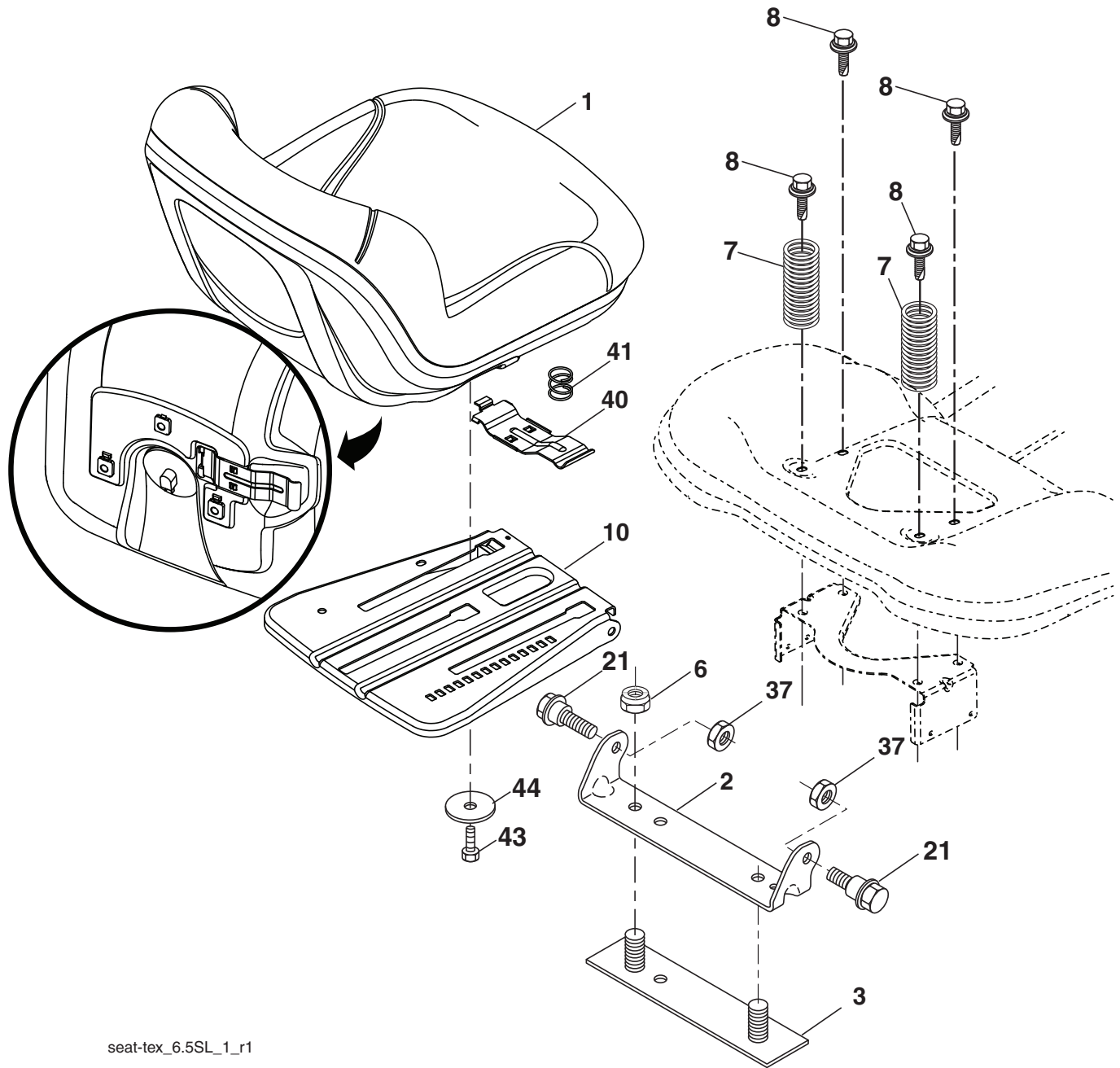

seat-tex_6.5SL_1_r1

KEY NO.	PART NO.	DESCRIPTION
1	532 42 40-73	Seat
2	532 18 01-66	Bracket Pivot Fender
3	532 14 06-75	Strap, Asm. Fender
6	873 80 06-00	Nut, Lock w/Ins. 3/8-16 unc
7	532 12 41-81	Spring, Seat Cprsn.
8	532 17 18-77	Bolt 5/16-18 x 3/4 unc w/Sems.
10	532 19 69-77	Pan, Seat
21	532 17 18-52	Bolt, Shoulder 5/16-18

KEY NO.	PART NO.	DESCRIPTION
37	873 80 05-00	Nut, Lock 5/16-18 unc
40	532 19 76-61	Handle Slide Seat
41	532 19 82-00	Spring Latch Seat
43	874 76 06-12	Bolt 3/8-16 x 3/4
44	819 13 38-12	Washer 13/32 x 2-3/8 x 12 Ga.

NOTE: All component dimensions given in U.S. inches
1 inch = 25.4 mm

