

ILLUSTRATED PARTS LIST

MFG. ID NO. 96041024900

CUSTOMER CATALOG NO. YTH 224T

PRODUCT NO. 960 41 02-49

**TRACTOR - - MODEL NO. YTH 224T (96041024900), PRODUCT NO. 960 41 02-49
DECALS 27**

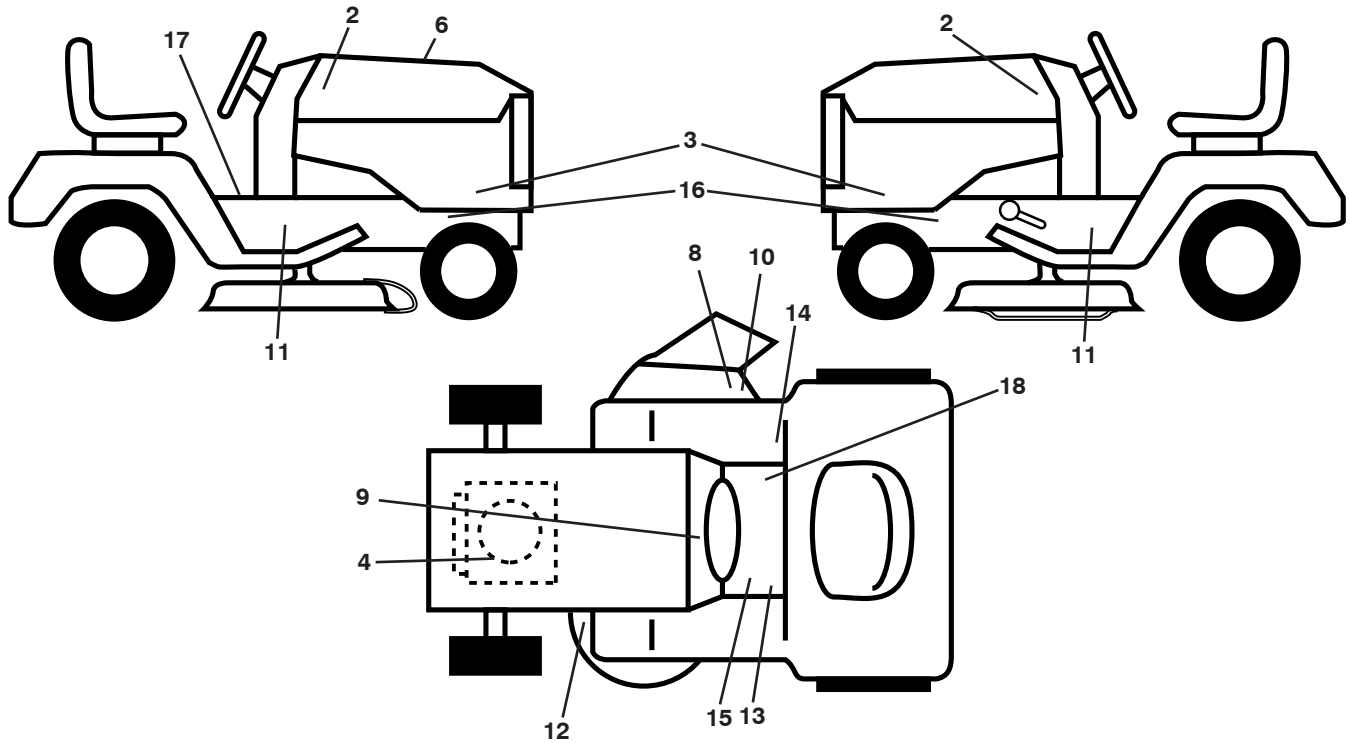

| KEY NO. | PART NO. | DESCRIPTION |
|---------|--------------|-------------------------------|
| 2 | 532 42 91-96 | Decal, Badge |
| 3 | 532 44 63-77 | Decal, Panel SD |
| 4 | 532 19 68-41 | Decal, Eng. HP |
| 6 | 532 43 94-28 | Decal, Replacement |
| 8 | 532 18 21-66 | Decal, Cutfinger |
| 9 | 532 14 50-05 | Decal, Battery Dnge/Poi |
| 10 | 532 19 63-57 | Decal, Defl. |
| 11 | 532 40 11-46 | Decal, Warning |
| 12 | 532 16 03-96 | Decal, Mower V-Belt Schematic |
| 13 | 532 40 03-89 | Decal, Warning Symbols |

| KEY NO. | PART NO. | DESCRIPTION |
|---------|--------------|---------------------|
| 14 | 532 18 04-32 | Decal, Fender |
| 15 | 532 15 97-37 | Decal, Brake/Clutch |
| 16 | 532 15 97-36 | Decal, Chassis |
| 17 | 532 14 08-37 | Decal, Saddle Brake |
| 18 | 532 17 83-02 | Decal, Oper. Cruise |
| -- | 532 16 25-98 | Decal, Drawbar |
| -- | 532 16 69-60 | Decal, Bypass |
| -- | 532 43 98-82 | Pad, Footrest, LH |
| -- | 532 43 98-81 | Pad, Footrest, RH |
| -- | 532 44 64-50 | Manual, Ops (Euro) |

WHEELS AND TIRES

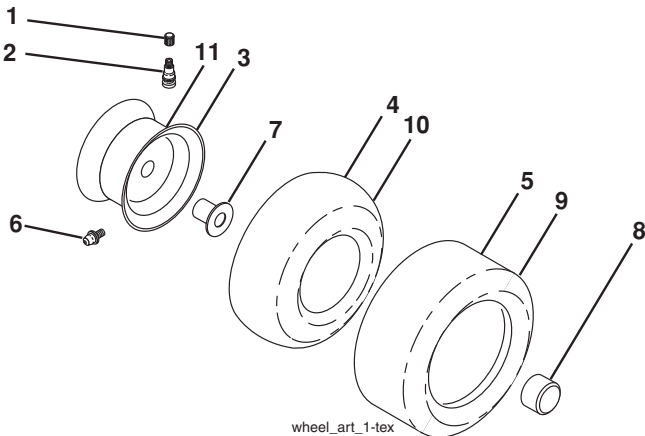

| KEY NO. | PART NO. | DESCRIPTION |
|---------|--------------|-----------------------------------|
| 1 | 532 05 91-92 | Cap Valve Tire |
| 2 | 532 06 51-39 | Stem Valve |
| 3 | 532 13 83-36 | Rim Front Service |
| 4 | 532 05 99-04 | Tube Front (Service Item Only) |
| 5 | 532 10 62-22 | Tire TM Front 15 x 6.00-6 |
| 6 | 532 12 49-57 | Fitting Grease (Front Wheel Only) |
| 7 | 532 12 49-59 | Bearing Flange (Front Wheel Only) |
| 8 | 532 17 50-39 | Cap Axle Blk 1 50 x 1 00 |
| 9 | 532 12 20-82 | Tire TM Rear 30 x 10.00-8 |
| 10 | 532 12 49-26 | Tube Rear (Service Item Only) |
| 11 | 532 13 83-37 | Rim Asm 8" rear Service |
| -- | 532 14 43-34 | Sealant, Tire (10 oz. Tube) |

NOTE: All component dimensions given in U.S. inches
1 inch = 25.4 mm

TRACTOR - - MODEL NO. YTH 224T (96041024900), PRODUCT NO. 960 41 02-49 SCHEMATIC **38**

SCH13

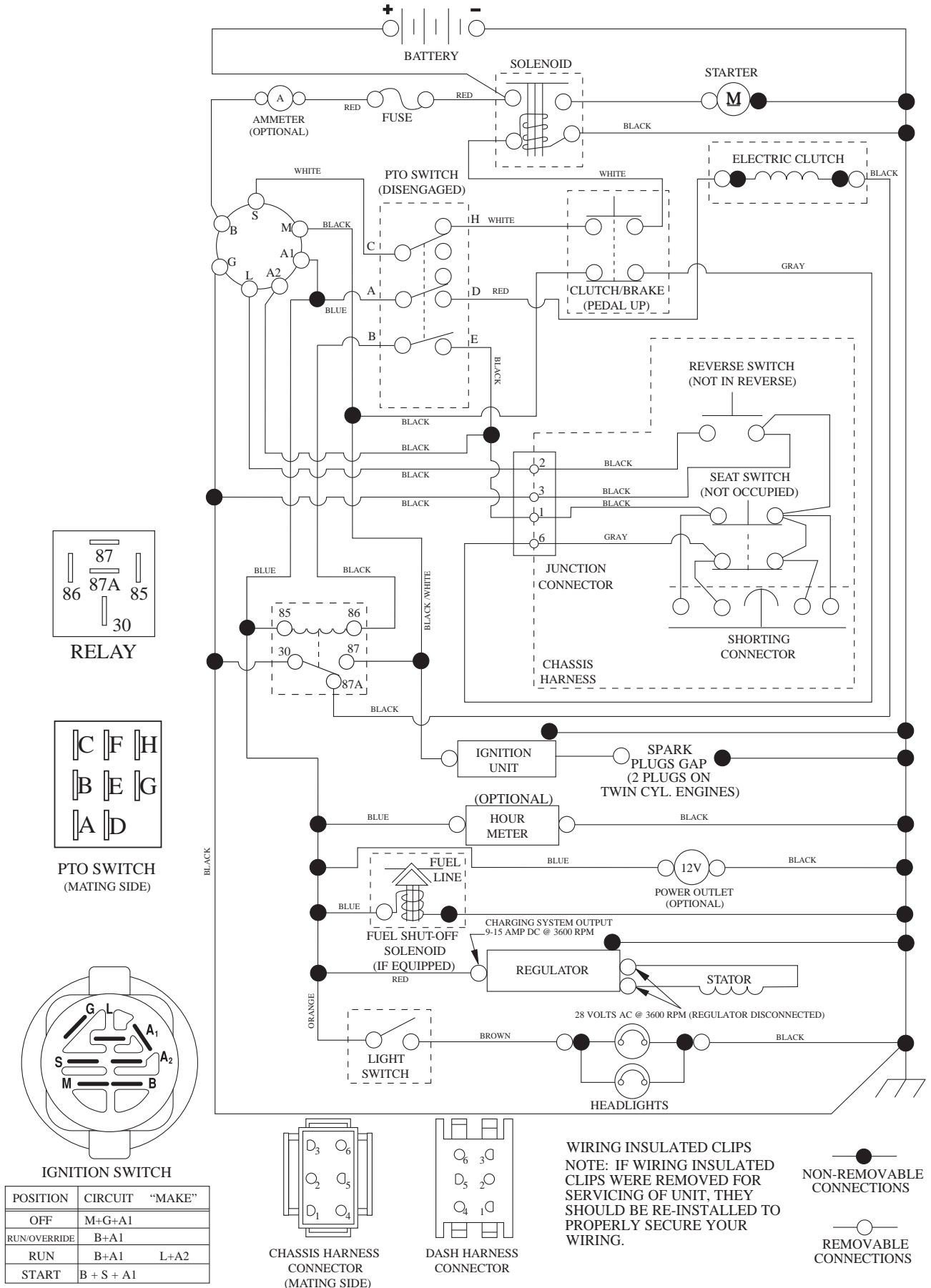

TRACTOR - - MODEL NO. YTH 224T (96041024900), PRODUCT NO. 960 41 02-49
ELECTRICAL 32

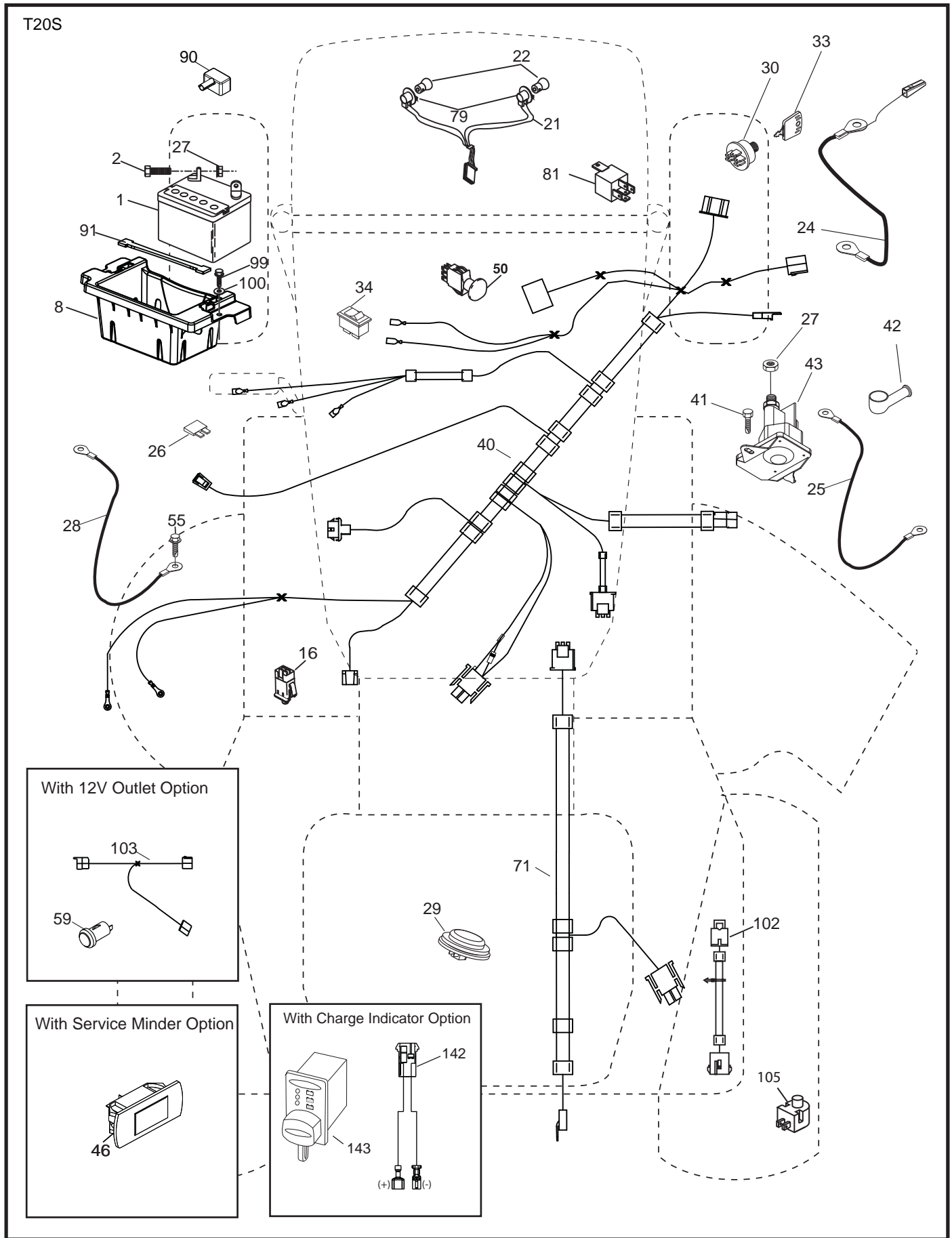

**TRACTOR - - MODEL NO. YTH 224T (96041024900), PRODUCT NO. 960 41 02-49
ELECTRICAL 32**

| KEY NO. | PART NO. | DESCRIPTION |
|----------------|-----------------|----------------------------------|
| 1 | 532 16 34-65 | Battery |
| 2 | 874 76 04-12 | Bolt Hex Head 1/4-20 x 3/4 |
| 8 | 532 18 64-91 | Box Battery |
| 16 | 532 17 61-38 | Switch Interlock Push-In |
| 21 | 532 40 02-52 | Harness Socket Light w/4152J |
| 22 | 532 00 41-52 | Bulb Light |
| 24 | 532 40 02-53 | Cable Battery |
| 25 | 532 41 28-95 | Cable Starter |
| 26 | 532 17 51-58 | Fuse |
| 27 | 873 51 04-00 | Nut Keps Hex 1/4-20 unc |
| 28 | 532 14 54-91 | Cable, Ground |
| 29 | 532 40 15-45 | Switch, Seat |
| 30 | 532 19 33-50 | Switch, Ign |
| 33 | 532 41 19-35 | Key\Chain |
| 34 | 532 11 07-12 | Switch Light / Reset |
| 40 | 532 40 96-14 | Harness Ign. Dash |
| 41 | 817 72 04-08 | Screw Thd Cut 1/4-20 x 1/2 |
| 42 | 532 13 15-63 | Cover, Terminal |
| 43 | 532 19 25-07 | Solenoid |
| 46 | 532 40 17-63 | Gauge Servicereminder Hrmtr |
| 50 | 532 17 46-51 | Switch PTO |
| 55 | 817 06 05-12 | Screw Thdrol 5/16-18 x 3/4 TYTT |
| 71 | 532 19 42-76 | Harness Ign. |
| 79 | 532 17 52-42 | Socket Asm Bulb Twistlock |
| 81 | 532 40 96-15 | Relay Harness Sealed |
| 90 | 532 43 53-95 | Cover Terminal |
| 91 | 532 19 02-70 | Strap Battery Mount |
| 99 | 817 67 04-12 | Screw Hexwsh Thdrol 1/4-20 x 3/4 |
| 100 | 819 09 14-16 | Washer 9/32 x 7/8 x 16 Ga. |
| 102 | 532 40 44-54 | Harness Pigtail |
| 105 | 532 40 75-68 | Switch Reverse TT Pedal Control |

NOTE: All component dimensions given in U.S. inches
1 inch = 25.4 mm

TRACTOR - - MODEL NO. YTH 224T (96041024900), PRODUCT NO. 960 41 02-49
CHASSIS AND ENCLOSURES **39**

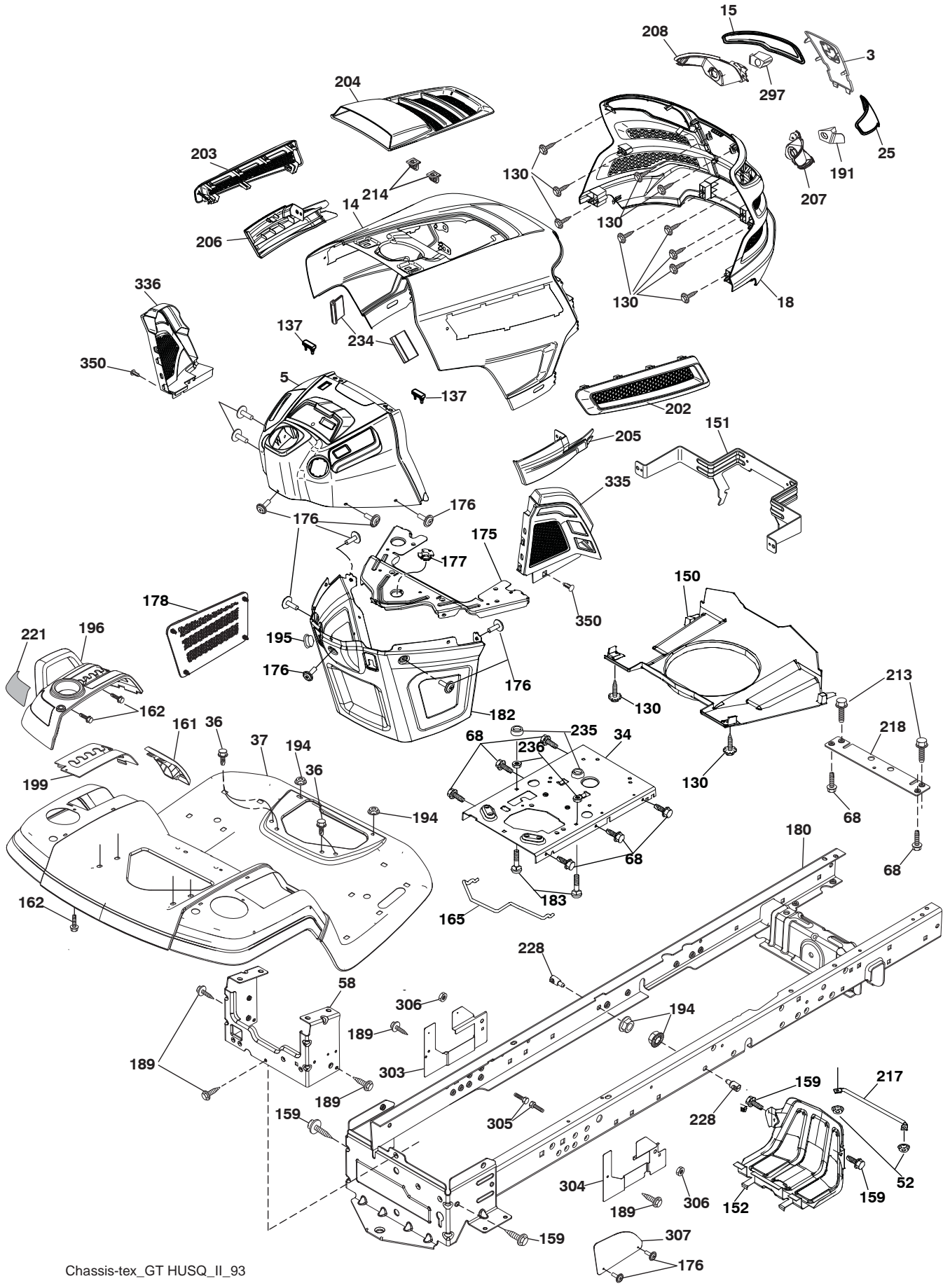

Chassis-tex_GT HUSQ_II_93

**TRACTOR - - MODEL NO. YTH 224T (96041024900), PRODUCT NO. 960 41 02-49
CHASSIS AND ENCLOSURES 39**

| KEY NO. | PART NO. | DESCRIPTION | KEY NO. | PART NO. | DESCRIPTION |
|------------|--------------|--------------------------------|------------|--------------|----------------------|
| 3 | 532 43 97-52 | Applique | 199 | 532 19 82-59 | Plate Deck Lift |
| 5 | 532 43 74-72 | Dash | 202 | 532 43 97-28 | Vent Side Hood RH |
| 14 | 532 44 11-77 | Hood | 203 | 532 43 97-27 | Vent Side Hood LH |
| 15 | 532 43 97-33 | Lens LH | 204 | 532 43 57-14 | Vent Top Hood |
| 18 | 532 44 06-53 | Grille/Lens Asm. | 205 | 532 43 97-30 | Skirt Hood Side RH |
| 25 | 532 44 33-85 | Lens RH | 206 | 532 43 97-29 | Skirt Hood Side LH |
| 34 | 532 19 61-25 | Plate Engine | 207 | 532 43 97-34 | Bezel RH |
| 36 | 817 06 05-12 | Screw 5/16-18 x 3/4 | 208 | 532 43 97-35 | Bezel LH |
| 37 | 532 44 12-08 | Fender | 213 | 874 76 05-12 | Bolt 5/16-18 x 3/4 |
| 52 | 873 68 05-00 | Nut Lock 5/16-18 | 214 | 532 19 91-45 | Clip Retainer Tinner |
| 58 | 532 41 22-81 | Drawbar Upper | 217 | 532 40 91-67 | Rod Pivot |
| 68 | 817 49 05-08 | Screw Thdrol 5/16-18 x 1/2 | 218 | 532 19 63-95 | X-Piece Hood Stop |
| 130 | 532 41 63-58 | Screw 10 x .750 BOS Thread | 221 | 532 19 89-09 | Reflective LH |
| 137 | 532 40 75-90 | Bumper Dash | 228 | 532 19 51-61 | Stud Fastner |
| 150 | 532 43 97-74 | Air Duct | 234 | 532 40 47-42 | Bumper Hood |
| 151 | 532 43 66-70 | Bracket Pivot Hood | 235 | 532 40 61-29 | Spacer Fender |
| 152 | 532 43 98-70 | Shield Browning | 236 | 873 93 05-00 | Nut Lock 5/16-18 unc |
| 159 | 817 00 06-12 | Screw Hexwsh Thdr 3/8-16 x 3/4 | 297 | 532 43 74-56 | Insert Reflective RH |
| 161 | 532 43 99-29 | Window, Fuel | 303 | 532 42 09-59 | Shield Chassis LH |
| 162 | 532 14 24-32 | Screw Hex Wsh 1/4 x 1/2 unc | 304 | 532 42 15-09 | Shield Chassis RH |
| 165 | 532 19 68-26 | Support Tank Rear | 305 | 872 11 06-06 | Bolt 3/8-16 x 3/4 |
| 175 | 532 19 63-04 | Crossmember | 306 | 873 90 06-00 | Nut Lock 3/8-16 unc |
| 176 | 532 40 07-76 | Screw 10-24 x 5/8 | 307 | 532 42 45-70 | Upper Shield Pedal |
| 177 | 532 19 52-27 | Bushing Steering | 335 | 532 44 82-04 | Cover RH Lower |
| 178 | 532 19 97-82 | Cargo Net Asm. | 336 | 532 44 53-09 | Cover LH Lower |
| 180 | 532 41 50-64 | Chassis | 350 | 532 44 51-43 | Clip X-mas Tree |
| 182 | 532 40 68-59 | Dash Lower | - - | 532 40 09-44 | Kit Bumper |
| 183 | 874 52 05-20 | Bolt 5/16-18 x 1-1/4 Full Thd. | | | |
| 189 | 817 00 05-12 | Screw 5/16-18 x 3/4 | | | |
| 191 | 532 43 74-55 | Insert Reflective LH | | | |
| 194 | 873 90 05-00 | Nut Lock Hex Flange 5/16-18 | | | |
| 195 | 532 40 41-37 | Plug Hole | | | |
| 196 | 532 43 97-16 | Console Asm Decklift | | | |

NOTE: All component dimensions given in U.S. inches
1 inch = 25.4 mm

TRACTOR - - MODEL NO. YTH 224T (96041024900), PRODUCT NO. 960 41 02-49
DRIVE **40**

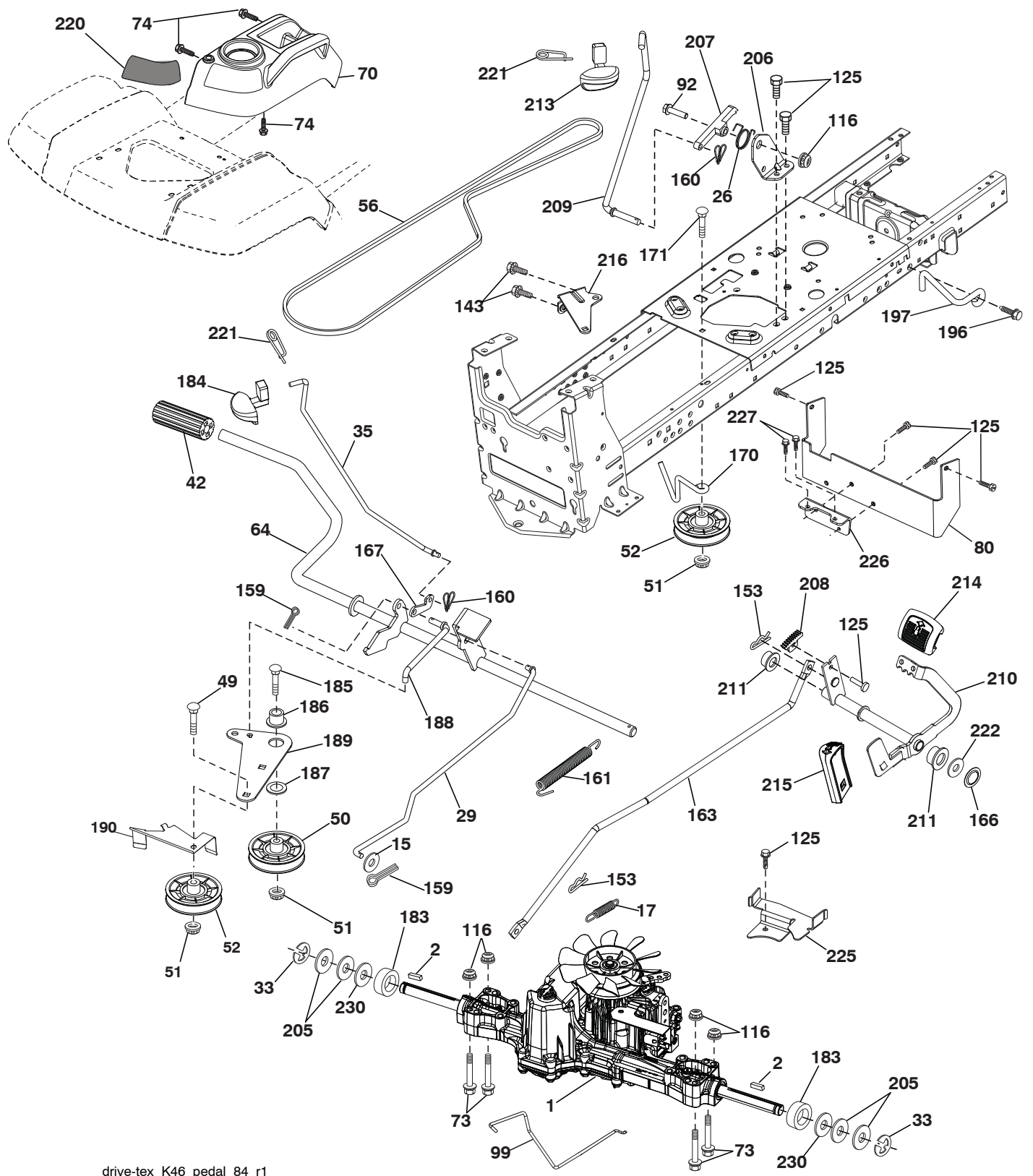

drive-tex_K46_pedal_84_r1

**TRACTOR - - MODEL NO. YTH 224T (96041024900), PRODUCT NO. 960 41 02-49
DRIVE 40**

| KEY NO. | PART NO. | DESCRIPTION | KEY NO. | PART NO. | DESCRIPTION |
|------------|--------------|---|------------|--------------|-------------------------------------|
| 1 | - - - - - | Transaxle, TUFFTORQ K46BT (426120) (Order parts from trans- axle manufacturer.) | 183 | 532 13 70-57 | Spacer Split |
| 2 | 532 12 35-83 | Key | 184 | 532 44 14-55 | Handle Parking Brake |
| 15 | 819 13 13-16 | Washer 13/32 x 13/16 x 16 Ga. | 185 | 872 11 06-22 | Bolt Rdhd Sqnk 3/8-16 x 2-3/4 Gr. 5 |
| 17 | 532 41 36-78 | Spring, Brake | 186 | 532 19 43-21 | Spacer Retainer |
| 26 | 532 19 96-79 | Spring Return Cruise | 187 | 819 13 32-10 | Washer |
| 29 | 532 40 38-06 | Rod, Brake | 188 | 532 19 43-23 | Link Clutch Ground Drive |
| 33 | 812 00 00-01 | Ring E | 189 | 532 19 43-17 | Bellcrank Ground Drive |
| 35 | 532 43 54-86 | Rod, Brake, Park | 190 | 532 19 43-18 | Keeper Bellcrank Ground Drive |
| 42 | 532 12 48-72 | Cover, Foot Pedal | 196 | 817 00 06-16 | Screw 3/8-16 x 1 |
| 49 | 872 11 06-14 | Bolt | 197 | 532 19 58-04 | Bracket Clutch Anti-Rotation |
| 50 | 532 19 43-27 | Pulley Idler Flat | 205 | 532 12 17-48 | Washer |
| 51 | 873 90 06-00 | Lock Nut 3/8-16 | 206 | 532 19 78-67 | Bracket Mount Latch Cruise |
| 52 | 532 19 43-26 | Idler V-Groove 910" Offset | 207 | 532 19 78-68 | Latch Control Cruise |
| 56 | 532 13 09-69 | V-Belt, Drive | 208 | 532 19 78-69 | Gear Sector Control Cruise |
| 64 | 532 19 78-65 | Shaft Asm. Pedal Brake Control | 209 | 532 19 95-92 | Rod Control Cruise |
| 70 | 532 43 96-61 | Console Asm | 210 | 532 19 78-60 | Rocker Asm. Pedal Control |
| 73 | 874 49 05-40 | Bolt Hex Flghd 5/16-18 Gr. 5 | 211 | 532 12 01-83 | Bearing Nylon |
| 74 | 532 14 24-32 | Screw Hex 1/4 x 1/2 unc | 213 | 532 40 31-19 | Knob Control Cruise |
| 80 | 532 44 06-19 | Bracket Strap Torque | 214 | 532 42 12-63 | Pedal Forward |
| 92 | 874 76 05-20 | Bolt Fin Hex 5/16-18 unc x 1.25 | 215 | 532 40 17-23 | Pedal Reverse |
| 99 | 532 41 57-42 | Rod Spring Bypass | 216 | 532 19 61-31 | Bracket Pulley Idler |
| 116 | 873 90 05-00 | Nut Lock Hex Flange 5/16-18 | 220 | 532 19 89-08 | Reflector RH |
| 125 | 817 00 05-12 | Screw 5/16-18 x 3/4 | 221 | 532 40 31-87 | Retainer Spring Clip Handle |
| 143 | 817 49 05-08 | Screw 5/16-18 x 1/2 | 222 | 879 21 20-10 | Washer 21/32 x 1-1/4 x 10 Ga. |
| 153 | 532 12 47-88 | Retainer Spring | 225 | 532 40 33-19 | Keeper Belt Trans. |
| 159 | 876 02 04-12 | Pin Cotter 1/8 x 3/4 | 226 | 532 40 15-64 | Bracket Mount Touque |
| 160 | 532 16 94-84 | Retainer Clip | 227 | 817 49 05-12 | Screw Thdrol 5/16-18 x 3/4 |
| 161 | 532 10 57-09 | Spring, Return, Clutch | 230 | 532 18 89-67 | Washer Hardened |
| 163 | 532 44 82-75 | Rod Pedal Control | | | |
| 166 | 532 42 91-64 | Nut Push | | | |
| 167 | 532 40 52-57 | Latch Brake Parking | | | |
| 170 | 532 19 43-22 | Keeper Belt Centerspan | | | |
| 171 | 872 11 06-16 | Bolt RDHD SQNK 3/8-16 unc x 2 | | | |

NOTE: All component dimensions given in U.S. inches
1 inch = 25.4 mm

TRACTOR - - MODEL NO. YTH 224T (96041024900), PRODUCT NO. 960 41 02-49
ENGINE **24**

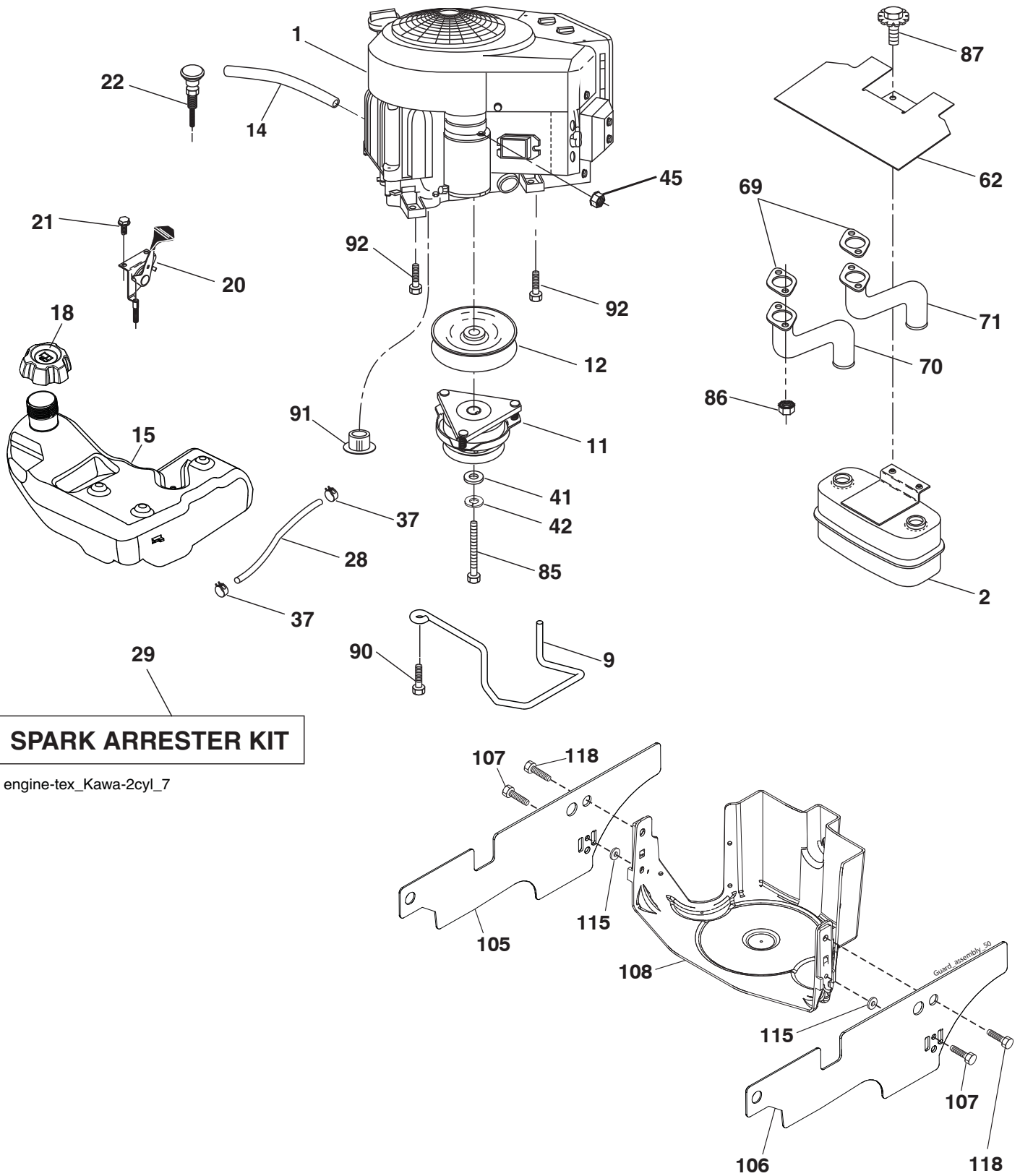

**TRACTOR - - MODEL NO. YTH 224T (96041024900), PRODUCT NO. 960 41 02-49
ENGINE 24**

| KEY NO. | PART NO. | DESCRIPTION |
|---------|--------------|---|
| 1 | --- | Engine KAWA FS651V-BS50 (445368) (Order parts from engine manufacturer.) |
| 2 | 532 14 97-23 | Muffler |
| 9 | 532 19 43-20 | Keeper Belt Engine |
| 11 | 532 40 00-08 | Clutch |
| 12 | 532 40 50-97 | Pulley Engine |
| 14 | 532 14 84-56 | Tube Drain Oil |
| 15 | 532 19 34-99 | Tank Fuel |
| 18 | 532 43 96-45 | Cap Asm Fuel |
| 20 | 532 17 83-85 | Control Throttle |
| 21 | 532 41 63-58 | Screw #10 x .750 BOS Thread |
| 22 | 532 19 15-96 | Control Choke |
| 28 | 532 40 11-35 | Fuel Line |
| 29 | 532 13 71-80 | Spark Arrester Kit |
| 37 | 532 12 34-87 | Clamp Hose |
| 41 | 532 12 61-97 | Washer 1-1/2 OD x 15/32 ID x .250 |
| 42 | 810 04 07-00 | Washer Lock 7/16 |
| 45 | 873 51 04-00 | Nut Keps Hex 1/4-20 unc |
| 62 | 532 43 40-17 | Heat Shield |
| 69 | 532 17 81-51 | Gasket |
| 70 | 532 42 47-65 | Exhaust Tube LH |
| 71 | 532 42 47-66 | Exhaust Tube RH |
| 85 | 532 17 39-37 | Bolt Hex 7/16-20 x 4 x Gr. 5-1.5 Thr |
| 86 | 532 18 43-62 | Nut Hex Flange 1.25 |
| 87 | 532 17 18-77 | Bolt 5/16-18 unc x 3/4 w/Sems |
| 90 | 817 00 06-16 | Screw 3/8-16 x 1 |
| 91 | 532 18 74-95 | Bushing |
| 92 | 817 12-06-16 | Screw 3/8-16 x 1 |
| 105 | 532 41 56-06 | Side Shield LH |
| 106 | 532 41 56-11 | Side Shield RH |
| 107 | 532 13 77-29 | Screw 1/4 - 20 x 5/8 |
| 108 | 532 42 68-03 | Cover Asm |
| 115 | 532 42 30-62 | Palnut 1/4 |
| 118 | 817 67 05-08 | Screw 5/16-18 x 1/2 |

NOTE: All component dimensions given in U.S. inches
1 inch = 25.4 mm

TRACTOR - - MODEL NO. YTH 224T (96041024900), PRODUCT NO. 960 41 02-49
STEERING ASSEMBLY **41**

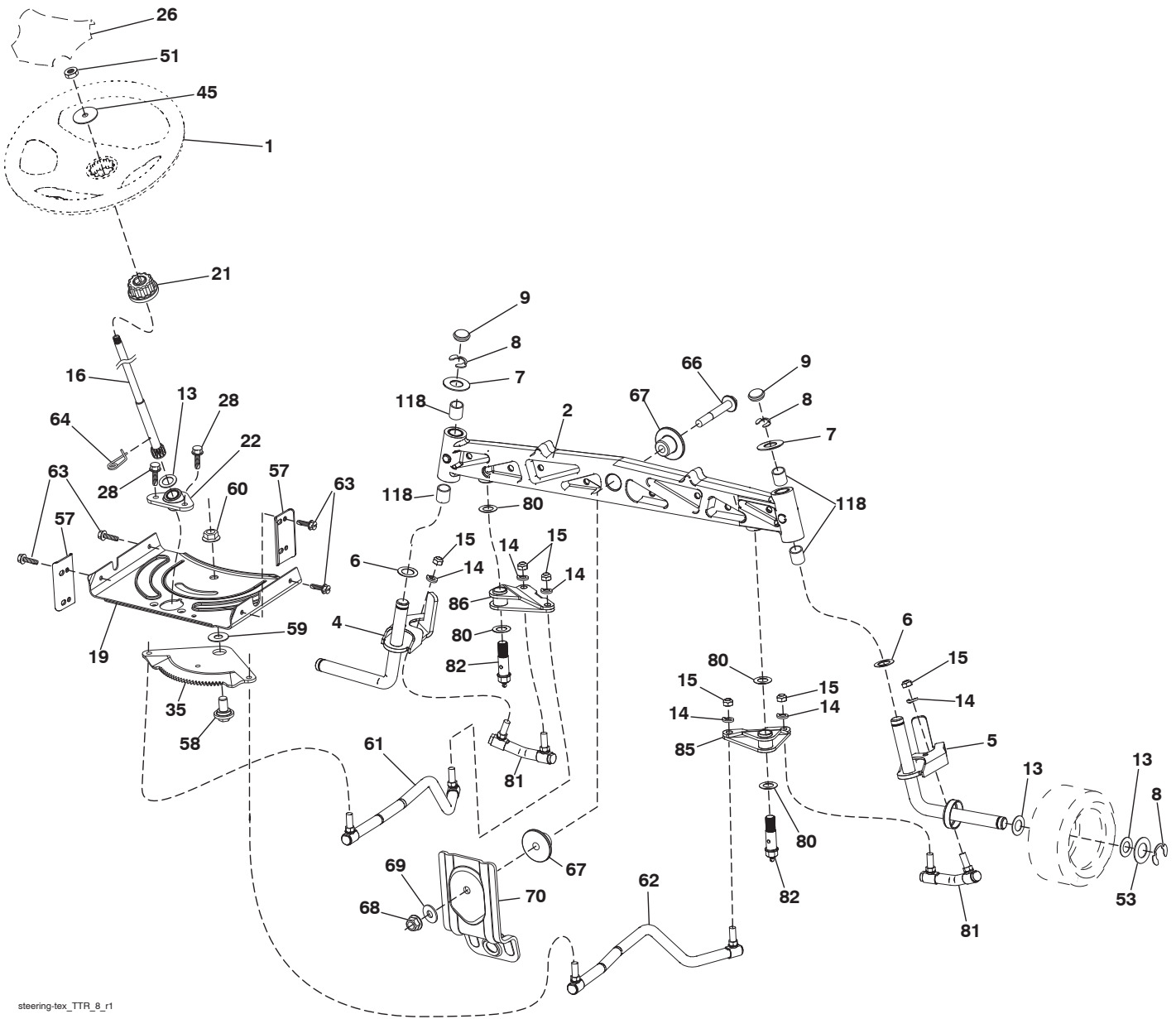

steering-tex_TTR_8_r1

**TRACTOR - - MODEL NO. YTH 224T (96041024900), PRODUCT NO. 960 41 02-49
STEERING ASSEMBLY **41****

| KEY NO. | PART NO. | DESCRIPTION |
|----------------|-----------------|-------------------------------------|
| 1 | 532 43 97-40 | Wheel, Steering |
| 2 | 532 43 68-70 | Axle Asm., Front |
| 4 | 532 43 68-73 | Spindle Asm., LH |
| 5 | 532 43 68-74 | Spindle Asm., RH |
| 6 | 532 12 49-31 | Washer Thrust 0.75 x 1.23 |
| 7 | 532 12 17-48 | Washer 25/32 x 1-5/8 x 16 Ga. |
| 8 | 812 00 00-29 | Ring, Klip #T5304-75 |
| 9 | 532 12 12-32 | Cap, Spindle |
| 13 | 532 12 17-49 | Washer 25/32 x 1-1/4 x 16 Ga. |
| 14 | 810 04 06-00 | Washer, Lock 3/8 |
| 15 | 873 54 06-00 | Nut, Crown Lock 3/8-24 unf |
| 16 | 532 44 42-12 | Shaft Steering |
| 19 | 532 19 47-29 | Plate Steering |
| 21 | 532 43 77-47 | Adapter, Wheel Steering |
| 22 | 532 19 48-45 | Bushing, Strg. Blk |
| 26 | 532 43 97-43 | Insert, Wheel Steering |
| 28 | 817 00 06-12 | Screw 3/8-16 x 3/4 |
| 35 | 532 44 07-70 | Gear, Sector Plate |
| 45 | 819 18 38-12 | Washer 9/16 ID x 2-3/8 OD x 12 Ga. |
| 51 | 873 94 08-00 | Nut Hex Jam Toplock 1/2-20 unf |
| 53 | 532 18 89-67 | Washer Hardened .793 x 1.637 x .060 |
| 57 | 532 40 74-65 | Bracket Upstop |
| 58 | 532 19 47-47 | Bolt Shoulder Sector Pivot CFM |
| 59 | 532 19 47-48 | Washer Thrust Sector Steering |
| 60 | 873 97 10-00 | Nut Flange Lock 5/8-11 |
| 61 | 532 43 68-84 | Draglink, LH |
| 62 | 532 43 68-85 | Draglink, RH |
| 63 | 817 00 05-12 | Screw 5/16-18 x 3/4 |
| 64 | 532 19 98-49 | Retainer Clip Spring Steering |
| 66 | 871 02 07-48 | Bolt Hex Fghd 7/16-14 x 3 Serr |
| 67 | 532 19 47-37 | Bushing PM Front Axle |
| 68 | 873 90 07-00 | Nut Lock Flange 7/16-14 Gr. 5 |
| 69 | 532 19 91-62 | Washer 1.5 x .505 x .118 |
| 70 | 532 19 61-97 | Bracket Deck Susp. Front |
| 80 | 532 00 13-70 | Washer |
| 81 | 532 43 68-87 | Link Cross RH |
| 82 | 532 43 68-77 | Pivot Bolt |
| 85 | 532 44 18-73 | Pivot RH |
| 86 | 532 44 18-72 | Pivot LH |
| 118 | 532 40 60-13 | Bushing |

NOTE: All component dimensions given in U.S. inches
1 inch = 25.4 mm

**TRACTOR - - MODEL NO. YTH 224T (96041024900), PRODUCT NO. 960 41 02-49
SEAT ASSEMBLY 42**

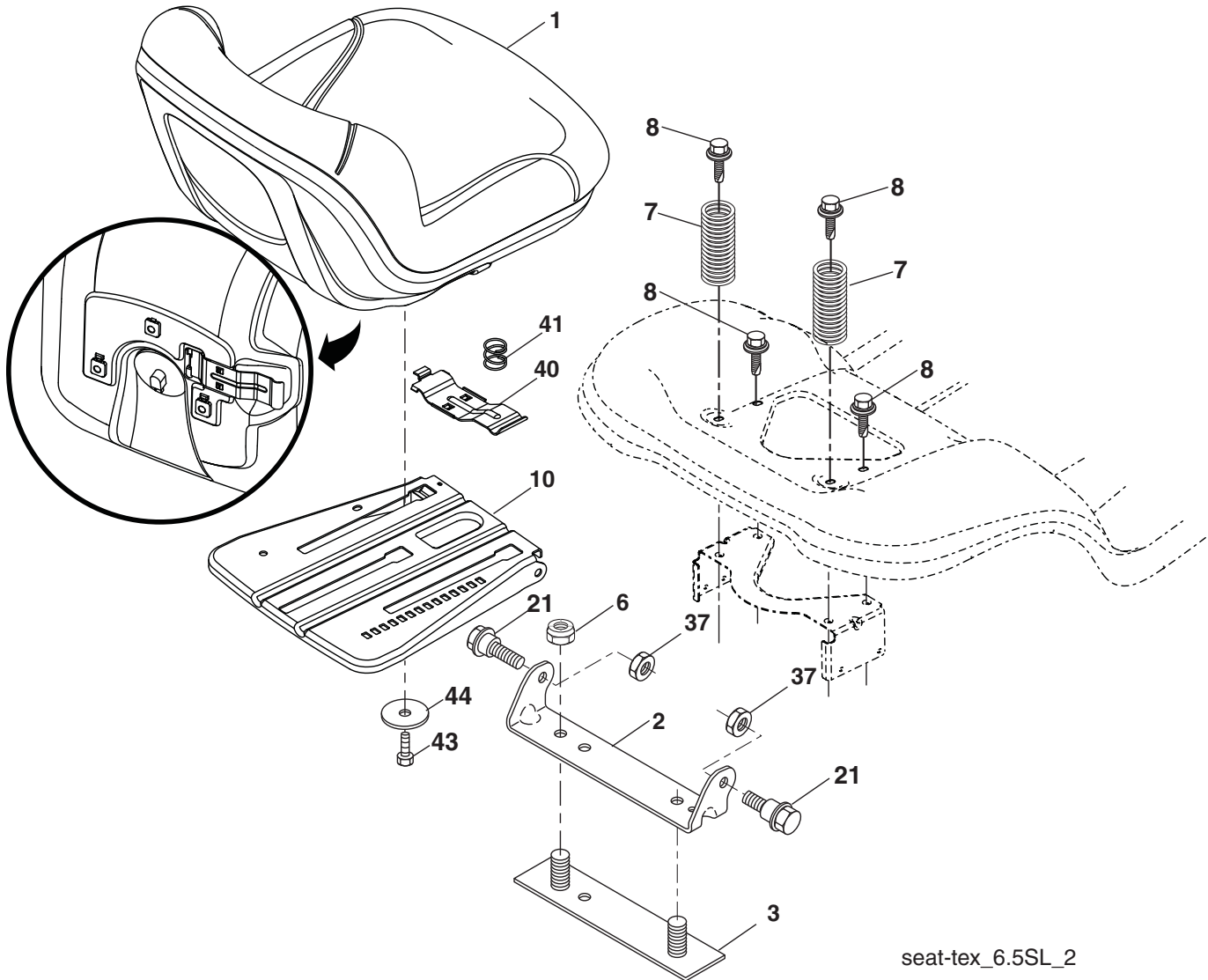

seat-tex_6.5SL_2

| KEY NO. | PART NO. | DESCRIPTION |
|---------|--------------|-------------------------------|
| 1 | 532 42 40-71 | Seat |
| 2 | 532 18 01-66 | Bracket Pivot Fender |
| 3 | 532 14 06-75 | Strap, Asm Fender |
| 6 | 873 80 06-00 | Nut, Lock W/Ins. 3/8-16 unc |
| 7 | 532 12 41-81 | Spring, Seat Cprsn |
| 8 | 532 17 18-77 | Bolt 5/16-18 unc x 3/4 w/Sems |
| 10 | 532 19 69-77 | Pan, Seat |
| 21 | 532 17 18-52 | Bolt, Shoulder 5/16-18 |

| KEY NO. | PART NO. | DESCRIPTION |
|---------|--------------|-------------------------------|
| 37 | 873 80 05-00 | Nut, Lock 5/16-18 unc |
| 40 | 532 19 76-61 | Handle Slide Seat |
| 41 | 532 19 82-00 | Spring Latch Seat |
| 43 | 874 76 06-12 | Bolt Fin Hex 3/8-16 unc x 3/4 |
| 44 | 819 13 38-12 | Washer 13/32 x 2-3/8 x 12 Ga. |

NOTE: All component dimensions given in U.S. inches
1 inch = 25.4 mm

**TRACTOR - - MODEL NO. YTH 224T (96041024900), PRODUCT NO. 960 41 02-49
MOWER LIFT 45**

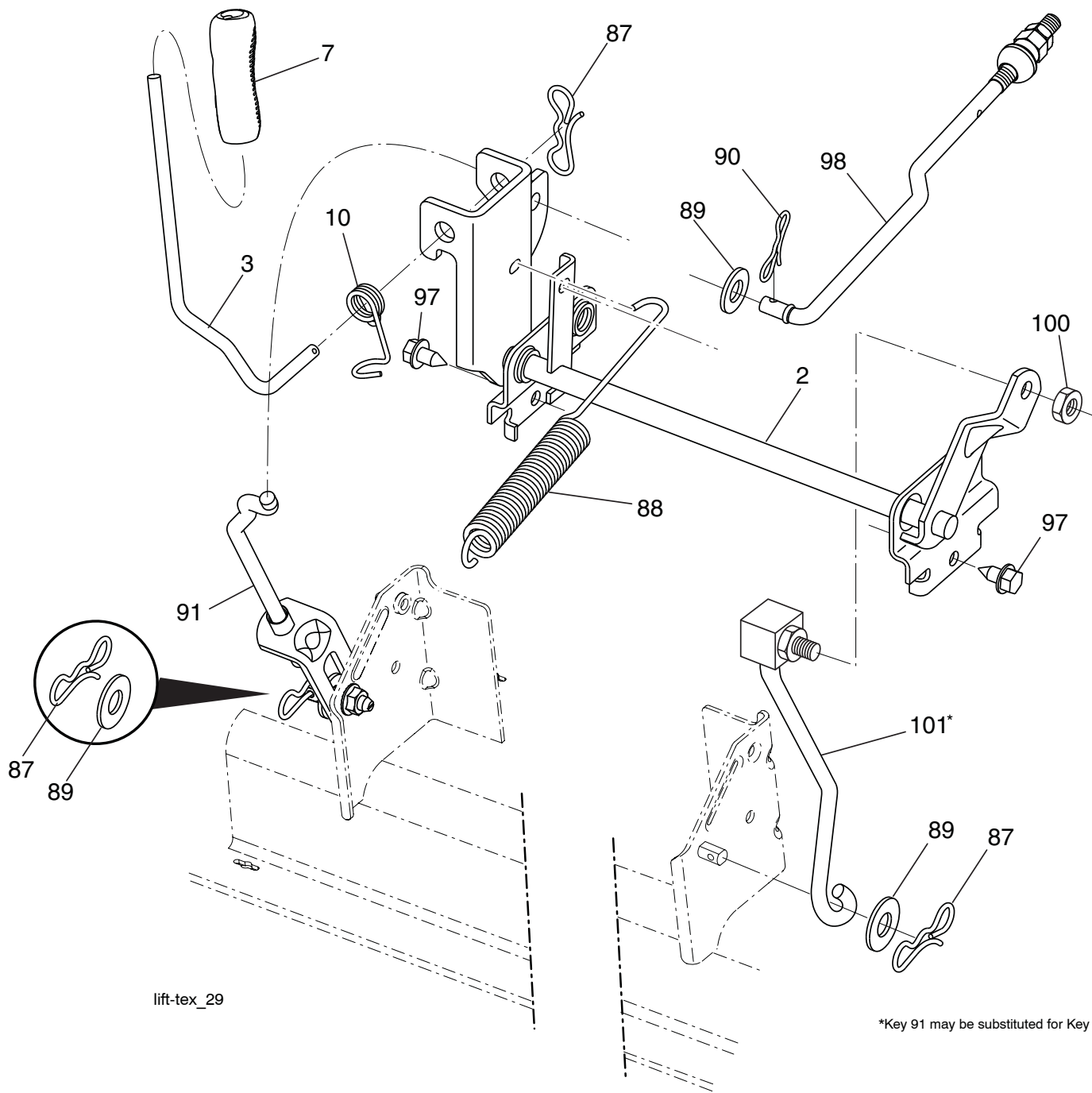

lift-tex_29

*Key 91 may be substituted for Key 101

| KEY NO. | PART NO. | DESCRIPTION |
|---------|--------------|------------------------------|
| 2 | 532 42 20-27 | Shaft Asm., Lift |
| 3 | 532 19 52-30 | Lever Lift Handle |
| 7 | 532 41 15-55 | Grip, Lever |
| 10 | 532 19 63-14 | Spring Torsion |
| 87 | 532 19 42-09 | Pin Cotter 7/16 Bow Tie Lock |
| 88 | 532 41 07-10 | Spring Lift Assist |
| 89 | 819 19 19-12 | Washer Clear Zinc |
| 90 | 532 19 42-08 | Pin Cotter 5/16 Bow Tie Lock |
| 91 | 532 19 51-81 | Link Lift Susp Mower Rear |

| KEY NO. | PART NO. | DESCRIPTION |
|---------|--------------|-----------------------------|
| 97 | 817 00 06-12 | Screw 3/8-16 x 3/4 |
| 98 | 532 19 52-70 | Link Asm. Susp. Front Mower |
| 100 | 873 93 06-00 | Nut Centerlock 3/8-16 unc |
| 101 | 532 40 70-03 | Link Lift Asm Fxd |

NOTE: All component dimensions given in U.S. inches
1 inch = 25.4 mm

TRACTOR - - MODEL NO. YTH 224T (96041024900), PRODUCT NO. 960 41 02-49
 MOWER DECK **44**

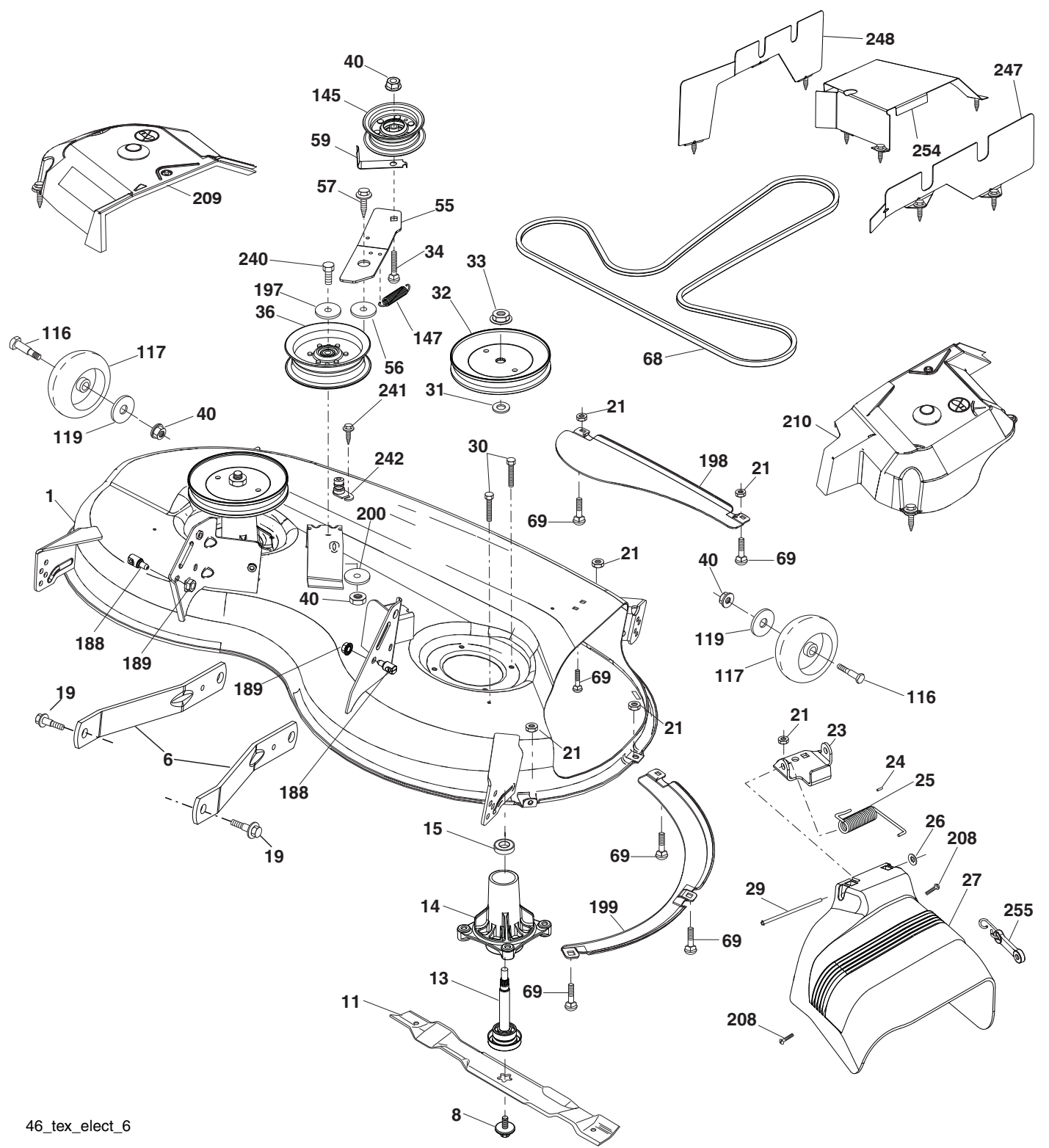

46_tex_elect_6

**TRACTOR - - MODEL NO. YTH 224T (96041024900), PRODUCT NO. 960 41 02-49
MOWER DECK 44**

| KEY NO. | PART NO. | DESCRIPTION | KEY NO. | PART NO. | DESCRIPTION |
|---------|--------------|------------------------------------|---------|--------------|---|
| 1 | 532 44 24-15 | Mower Housing | 147 | 532 19 72-51 | Spring Return |
| 6 | 532 19 51-86 | Arm Suspension | 188 | 532 19 51-61 | Stud Fastener |
| 8 | 532 19 30-03 | Bolt/Washer asm 7/16-20 unf | 189 | 873 90 05-00 | Nut Lock Hex Flange |
| 11 | 532 40 53-80 | Blade Mower Hi Lift | 197 | 819 13 13-12 | Washer 13/32 x 13/16 x 12 Ga. |
| 13 | 532 19 28-72 | Shaft Assembly, Mandrel | 198 | 532 40 31-49 | Baffle Center Front |
| 14 | 532 18 72-81 | Housing, Mandrel | 199 | 532 40 31-50 | Baffle Front RH |
| 15 | 532 11 04-85 | Bearing, Ball, Mandrel | 200 | 532 41 35-24 | Washer 13/32 x 1 x 1/2 11 GAHRD |
| 19 | 532 19 65-39 | Bolt, Shoulder | 208 | 817 67 06-08 | Screw Thdrol 3/8-16 x 1/2 |
| 21 | 873 68 05-00 | Nut | 209 | 532 43 23-95 | Cover Asm LH |
| 23 | 532 19 25-57 | Bracket, Deflector | 210 | 532 43 23-96 | Cover Asm RH |
| 24 | 532 10 53-04 | Cap, Sleeve | 240 | 874 52 06-36 | Bolt 3/8-16 unc x 2-1/4 Gr. 5 |
| 25 | 532 19 70-26 | Spring, Torsion, Deflector | 241 | 532 15 29-27 | Screw |
| 26 | 532 11 04-52 | Nut, Push | 242 | 532 41 55-98 | Washout Port |
| 27 | 532 44 28-95 | Shield, Deflector | 247 | 532 43 23-98 | Cover Asm RH |
| 29 | 532 13 14-91 | Rod, Hinge | 248 | 532 43 23-97 | Cover Asm LH |
| 30 | 532 17 39-84 | Screw Thdrol Rolling Wsh Hd | 254 | 532 43 23-99 | Shield Deck Rear |
| 31 | 532 18 76-90 | Washer, Spacer | 255 | 532 43 60-87 | Kit Bungee (Includes Phillips heas screw, weld nut, screw, bungee latch, and bungee strap) |
| 32 | 532 19 74-73 | Pulley, Mandrel | -- | 532 19 28-70 | Mandrel Assembly (Includes housing, shaft assembly, and bearing only - pulley/nut/washer and blade bolt/washers not included) |
| 33 | 532 40 02-34 | Nut, Toplock, Flanged | -- | 532 42 17-97 | Replacement Mower, Complete |
| 34 | 872 11 06-12 | Bolt Carr Sh. 3/8-16 x 1-1/2 Gr. 5 | | | |
| 36 | 532 19 73-79 | Pulley, Idler, Flat | | | |
| 40 | 873 90 06-00 | Nut, Lock Flg. 3/8-16 unc | | | |
| 55 | 532 19 72-49 | Arm, Idler | | | |
| 56 | 532 19 90-92 | Spacer, Retainer | | | |
| 57 | 817 00 06-16 | Screw Hexwsh Thd 3/8-16 x 1 | | | |
| 59 | 532 14 10-43 | Guard, Tuv Idler (94) | | | |
| 68 | 532 40 51-43 | V-Belt | | | |
| 69 | 872 14 05-05 | Bolt | | | |
| 116 | 532 19 34-06 | Bolt, Shoulder | | | |
| 117 | 532 17 48-73 | Wheel, Gauge | | | |
| 119 | 819 13 20-12 | Washer 13/32 x 1-1/2 x 11 Ga. | | | |
| 145 | 532 19 31-97 | Pulley Idler | | | |

NOTE: All component dimensions given in U.S. inches
1 inch = 25.4 mm

