

CTH153

Spare parts

Ersatzteile

Pièces détachées

Reserve onderdelen

Repuestos

Reservdelar

ILLUSTRATED PARTS LIST

MODEL NO. 96051001501

CUSTOMER CATALOG NO. CT153

PRODUCT NO. 960 51 00-15

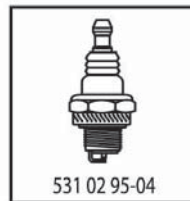

47

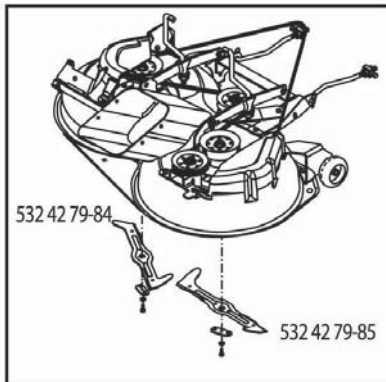
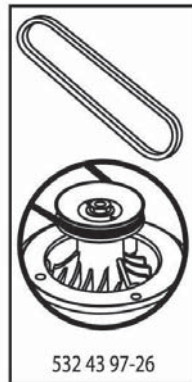

439836

TRACTOR - - MODEL NO. CT153 (96051001501), PRODUCT NO. 960 51 00-15
DECALS 27

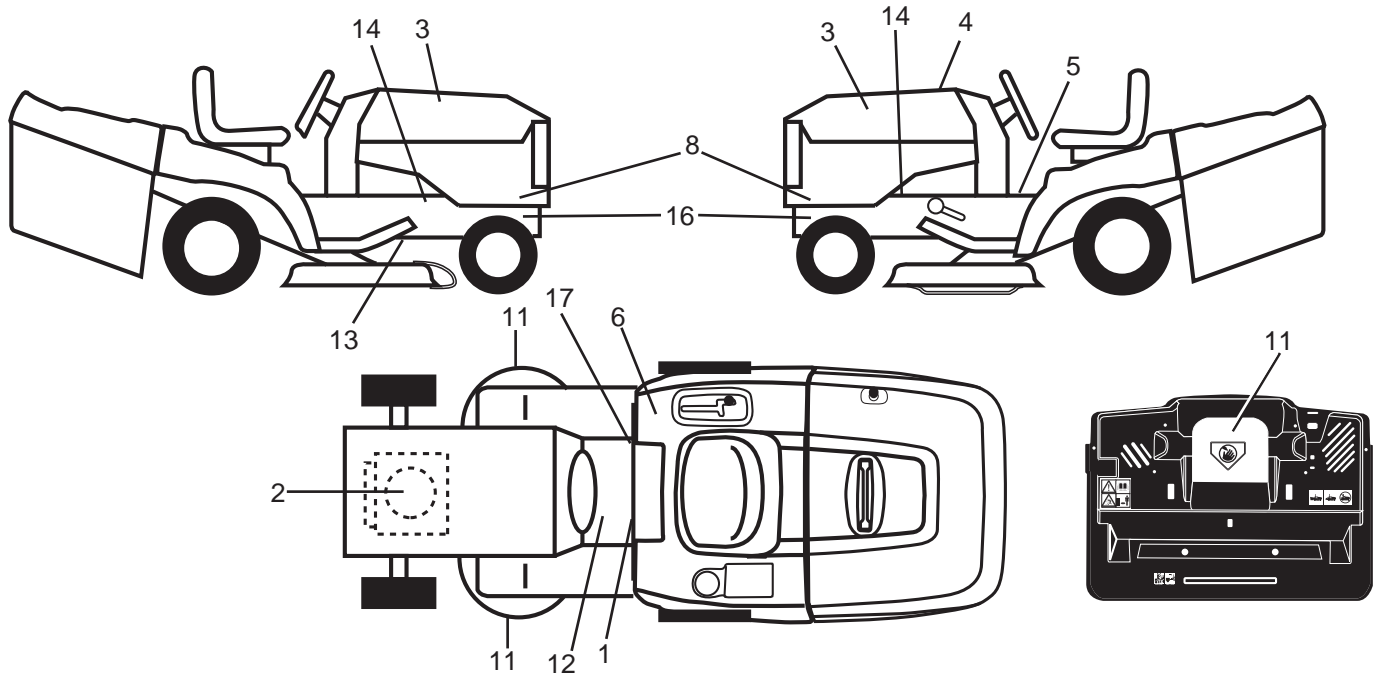

KEY NO.	PART NO.	DESCRIPTION
1	532 40 03-89	Decal, Warning Sym. CE
2	532 19 68-41	Decal, Warning Eng. Sym.
3	532 42 91-96	Decal, Hood Emblem
4	532 43 98-36	Decal, Replacement
5	532 40 03-89	Decal, Warning Symbols
6	532 18 04-32	Decal, Fender 100DB/CE
8	532 44 03-70	Decal, Side Panel

KEY NO.	PART NO.	DESCRIPTION
11	532 18 21-66	Decal, Mower Cut Finger Symbol
12	532 15 97-37	Decal, Brake/Clutch Symbol Lt
13	532 44 11-89	Decal, V-Belt
14	532 15 97-36	Decal, Chassis Hot Muffler
16	532 40 11-46	Decal, Warning Service Fire
17	532 14 08-37	Decal, Saddle Brake Parking
--	532 44 14-09	Pad Footrest LH
--	532 44 18-02	Pad Footrest RH
--	532 44 10-26	Manual Operator's (Euro)

WHEELS AND TIRES

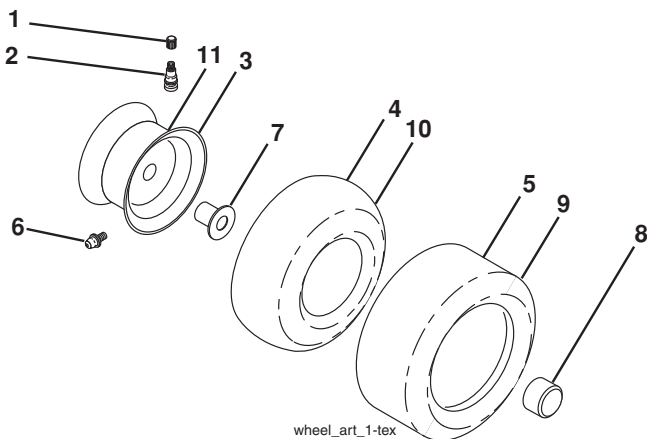

KEY NO.	PART NO.	DESCRIPTION
1	532 05 91-92	Cap Valve Tire
2	532 06 51-39	Stem Valve
3	532 13 83-36	Rim Asm. 6" Front
4	532 05 99-04	Tube Front (Service Item Only)
5	532 10 62-22	Tire F T 15 x 6 0 - 6
6	532 12 49-57	Fitting Grease (Front Wheel Only)
7	532 12 49-59	Bearing Flange (Front Wheel Only)
8	532 17 50-39	Cap Axle Blk. 1 50 x 1 00
9	532 42 05-31	Tire R 18 x 9.5-8 Turf Saver LT
10	532 12 49-26	Tube Rear (Service Item Only)
11	532 13 83-37	Rim Asm. 8" Rear
--	532 14 43-34	Sealant, Tire (10 oz. Tube)

NOTE: All component dimensions given in U.S. inches
 1 inch = 25.4 mm

TRACTOR - - MODEL NO. CT153 (96051001501), PRODUCT NO. 960 51 00-15

SCHEMATIC 38

SCH17

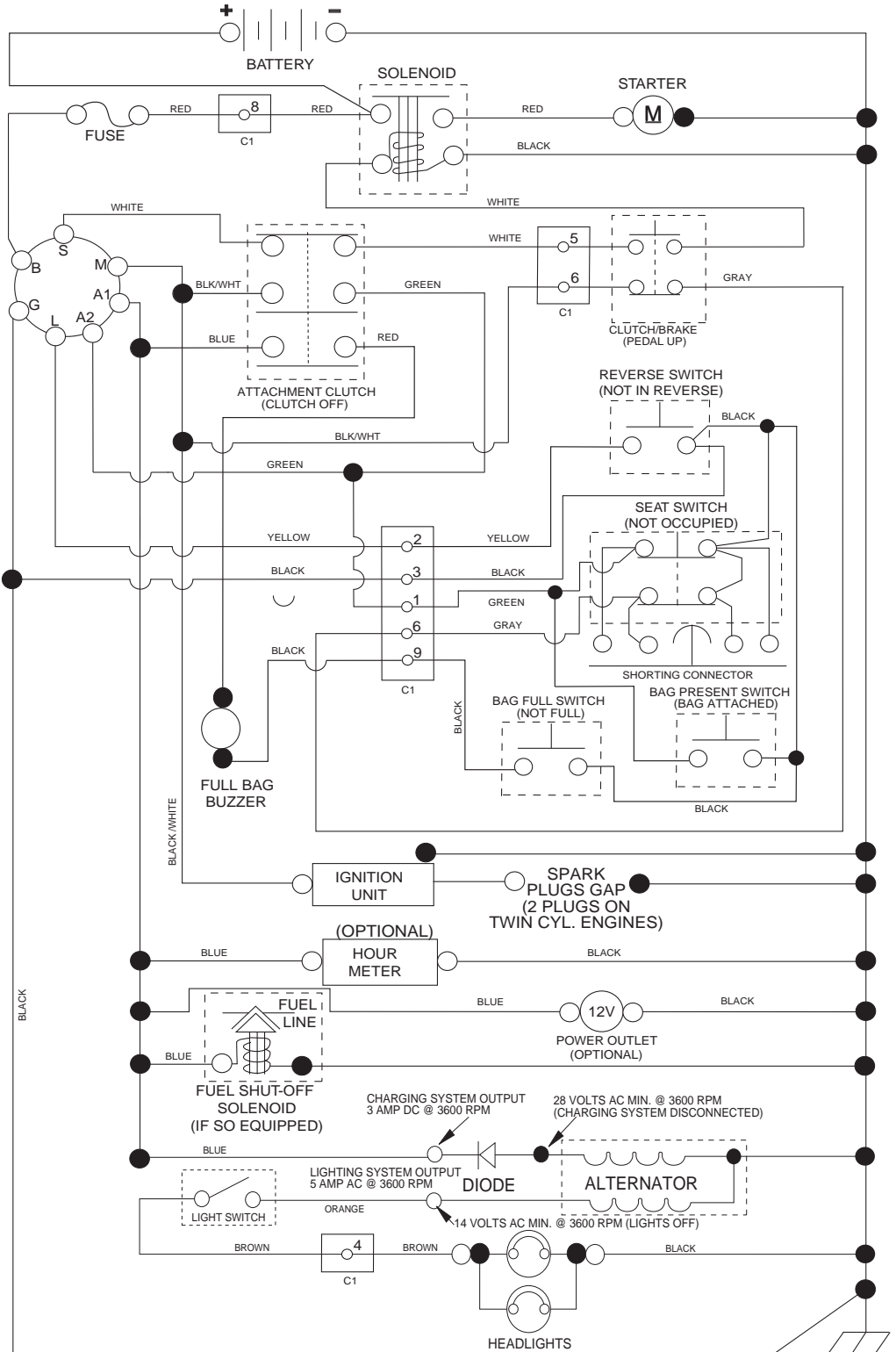

NOTE
 YOUR TRACTOR IS EQUIPPED WITH A SPECIAL ALTERNATOR SYSTEM. THE LIGHTS ARE NOT CONNECTED TO THE BATTERY, BUT HAVE THEIR OWN ELECTRICAL SOURCE. BECAUSE OF THIS, THE BRIGHTNESS OF THE LIGHTS WILL CHANGE WITH ENGINE SPEED. AT IDLE THE LIGHTS WILL DIM. AS THE ENGINE SPEED IS INCREASED, THE LIGHTS WILL BECOME THEIR BRIGHTEST.

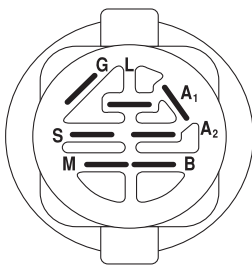

IGNITION SWITCH

POSITION	CIRCUIT	"MAKE"
OFF	M+G+A1	
RUN/OVERRIDE	B+A1	
RUN	B+A1	L+A2
START	B + S + A1	

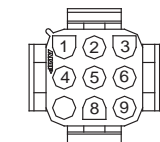

CHASSIS HARNESS CONNECTOR (C1) (MATING SIDE)

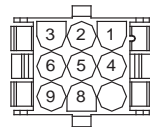

DASH HARNESS CONNECTOR (C1) (MATING SIDE)

WIRING INSULATED CLIPS
 NOTE: IF WIRING INSULATED CLIPS WERE REMOVED FOR SERVICING OF UNIT, THEY SHOULD BE RE-INSTALLED TO PROPERLY SECURE YOUR WIRING.

NON-REMOVABLE CONNECTIONS

REMOVABLE CONNECTIONS

TRACTOR - - MODEL NO. CT153 (96051001501), PRODUCT NO. 960 51 00-15
ELECTRICAL **32**

TC01S

With Service Minder Option

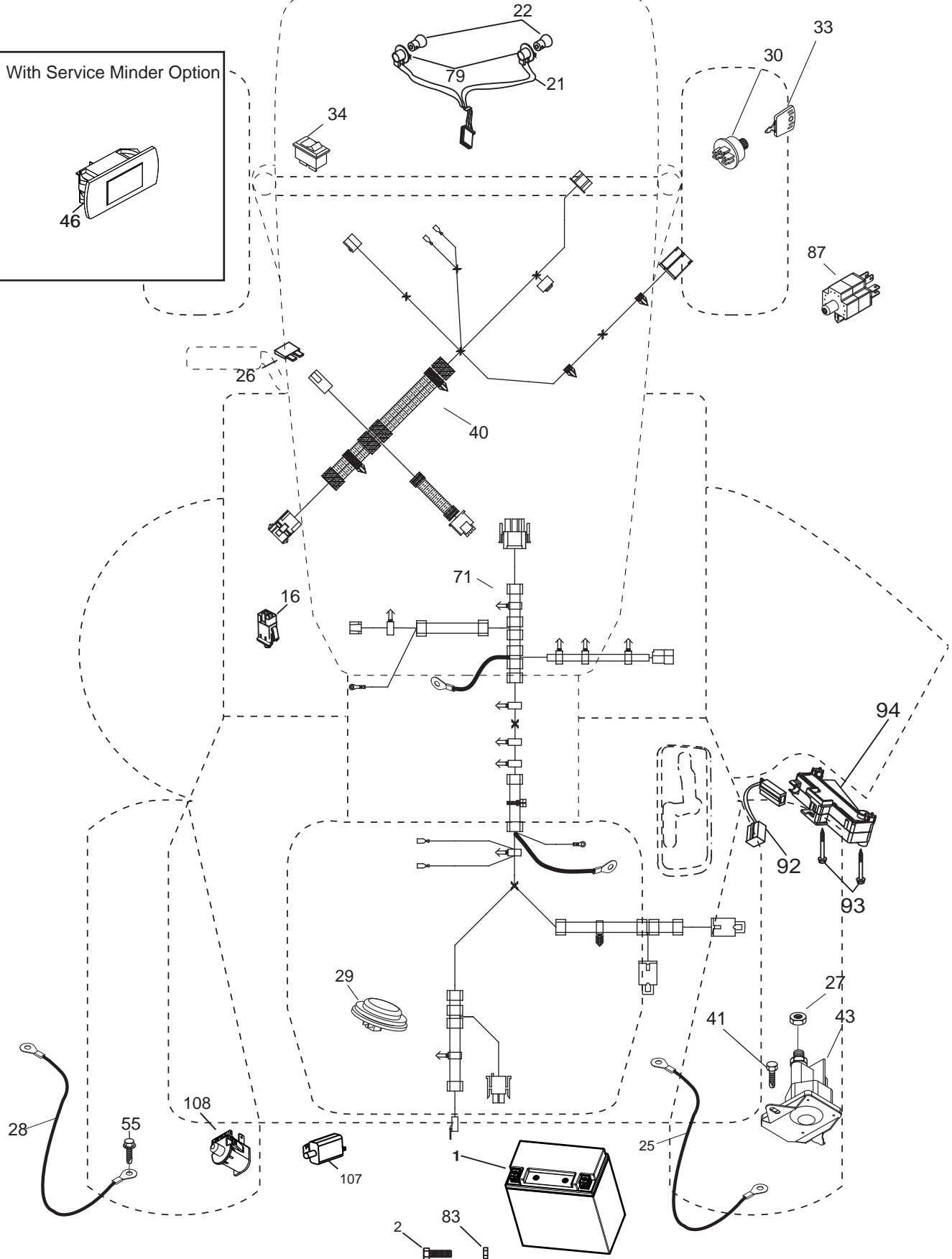
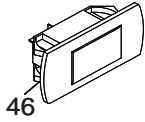

TRACTOR - - MODEL NO. CT153 (96051001501), PRODUCT NO. 960 51 00-15
ELECTRICAL 32

KEY NO.	PART NO.	DESCRIPTION
1	532 43 71-57	Battery
2	532 44 09-23	Screw Hex Head Cap M6 x 1.12 mm
16	532 17 61-38	Switch Interlock Push-In
21	532 40 02-52	Harness Socket Light w/4152J
22	532 00 41-52	Bulb Light
25	532 43 71-62	Cable Starter
26	532 17 51-58	Fuse
27	873 51 04-00	Nut Keps Hex 1/4-20 unc
28	532 43 71-63	Cable, Ground
29	532 40 15-45	Switch, Seat
30	532 19 33-50	Switch, Ign.
33	532 41 19-35	Key/Chain
34	532 11 07-12	Switch Light/Reset
40	532 42 10-02	Harness Ign. Dash
41	817 72 04-08	Screw Thd. Cut 1/4-20 x 1/2
42	532 13 15-63	Cover, Terminal
43	532 19 25-07	Solenoid
55	817 06 05-12	Screw Thdrol. 5/16-18 x 3/4 TYTT
71	532 43 71-60	Harness Chassis
79	532 17 52-42	Socket Asm. Bulb Twistlock
83	532 43 67-74	Nut Square M6 x 1.8.5 x 11 mm
87	532 42 10-60	Switch Railmount No-Nc-Nc
92	532 19 66-15	Harness Pigtail Reverse Switch
93	532 19 25-40	Screw Plastite 10-14 x 2.0
94	532 19 18-34	Module Reverse ROS
107	532 18 03-79	Switch Full Bagger Indicator
108	532 42 10-62	Switch Snapmount

NOTE: All component dimensions given in U.S. inches
1 inch = 25.4 mm

TRACTOR - - MODEL NO. CT153 (96051001501), PRODUCT NO. 960 51 00-15
CHASSIS AND ENCLOSURES **39**

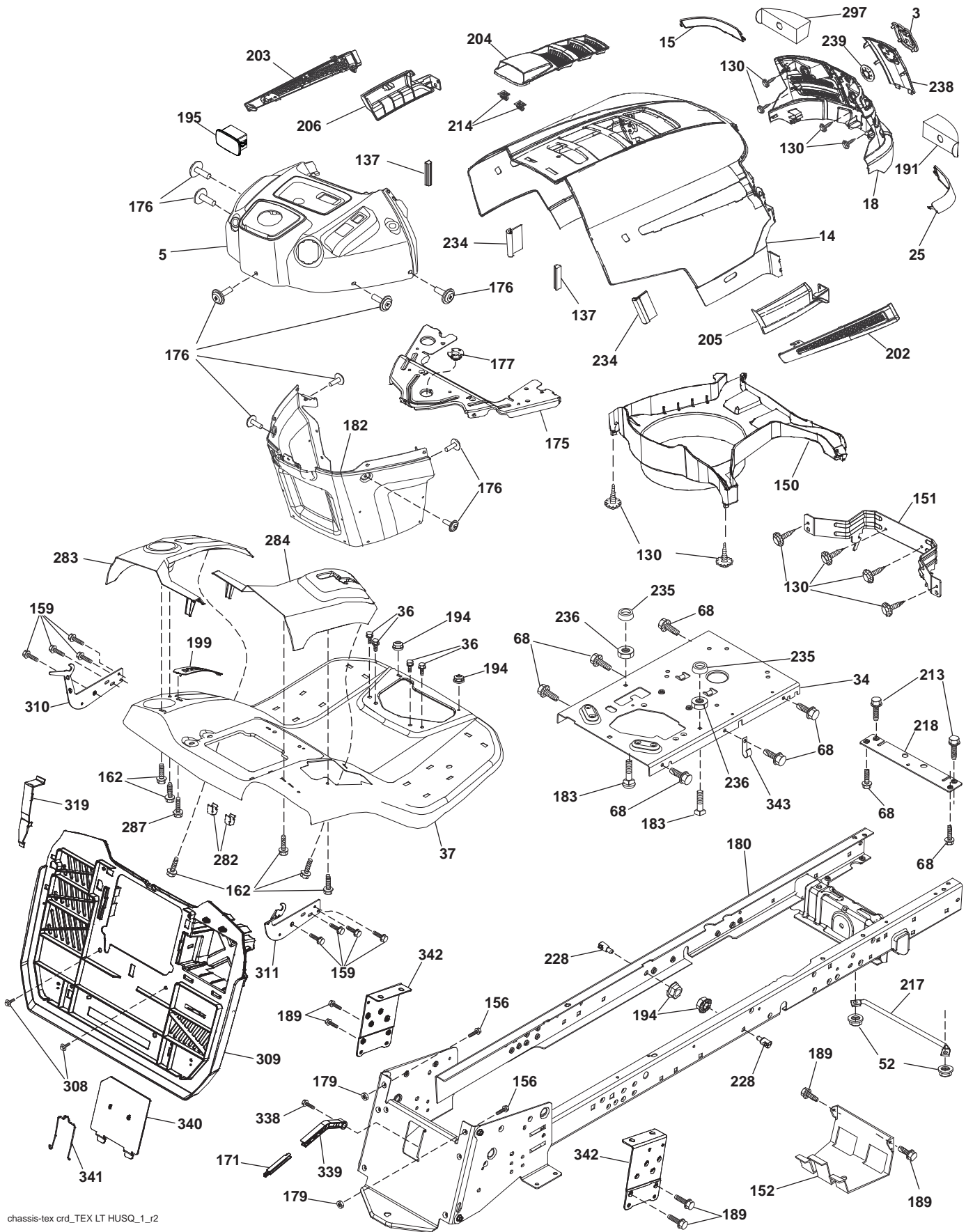

chassis-tex crd_TEX LT HUSQ_1_r2

TRACTOR - - MODEL NO. CT153 (96051001501), PRODUCT NO. 960 51 00-15
CHASSIS AND ENCLOSURES 39

KEY NO.	PART NO.	DESCRIPTION	KEY NO.	PART NO.	DESCRIPTION
3	532 40 50-12	Logo	205	532 44 13-44	Skirt Side RH
5	532 43 89-64	Dash	206	532 44 13-45	Skirt Side LH
14	532 44 12-67	Hood	213	874 76 05-12	Bolt Hex HD 5/16-18 unc 3/4
15	532 44 14-28	Lens LH	214	532 19 91-45	Clip Retainer
18	532 44 13-68	Grille	217	532 40 91-67	Rod Pivot Hood
25	532 44 14-27	Lens RH	218	532 19 63-95	X-Piece Hood Stop
34	532 19 61-25	Plate Engine	228	532 19 51-61	Stud Fastener
36	817 06 05-12	Screw 5/16-18 x 3/4	234	532 40 47-42	Bumper Hood
37	532 44 13-69	Fender	235	532 40 61-29	Spacer Fender
52	873 68 05-00	Nut Crownlock 5/16-18	236	873 93 05 00	Nut Center Lock 5/16-18 unc
68	817 49 05-08	Screw Thdrol. 5/16-18 x 1/2	238	532 44 13-74	Trim
130	532 41 63-58	Screw #10 x .750 BOS Thread	239	532 40 48-83	Clip Tinnerman
137	532 40 75-90	Bumper Dash	282	532 41 41-10	Clip Retainer
150	532 40 75-37	Air Duct	283	532 44 05-31	Console Deck Lift
151	532 40 78-07	Bracket Pivot	284	532 44 08-59	Console Shift RH
152	532 19 95-35	Shield Browning	287	817 60 04-06	Screw Hex Wash. 1/4-20 x 3/8
156	872 14 06-14	Bolt 3/8-16 unc x 1-3/4	297	532 40 66-65	Insert Reflective LH
159	817 00 06-12	Screw 3/8-16 x 3/4	308	532 17 18-77	Bolt 5/16-18 unc x 3/4
162	532 14 24-32	Screw Hex Wsh. Hi-Lo 1/4 x 1/2 unc	309	532 43 66-26	Backplate
171	532 44 12-89	Extension Bagger Full	310	532 43 68-88	Bracket Hangbar Bag LH
175	532 19 94-72	Crossmember	311	532 43 68-89	Bracket Hangbar Bag RH
176	532 40 07-76	Screw 10-24 x 5/8	319	532 17 46-62	Bracket Actuator Bagger
177	532 19 52-28	Bushing Steering	338	532 43 66-40	Bolt Shoulder
179	532 16 89-37	Nut Push	339	532 44 12-88	Lever Bagger Full
180	532 43 54-72	Chassis	340	532 44 09-31	Door Battery Tray
182	532 40 71-76	Dash Lower	341	532 43 66-38	Latch Batter Tray
183	874 52 05-20	Bolt 5/16-18 x 1-1/4	342	532 43 59-38	Support Fender
189	817 00 05-12	Screw 5/16-18 x 3/4	343	532 44 07-49	Clip
191	532 41 65-01	Insert Reflective RH			
194	873 90 05-00	Nut Lock Hex Flange 5/16-18			
195	532 43 99-76	Plug Dash			
199	532 41 87-39	Plate Deck Lift			
202	532 44 13-42	Vent Side Hood RH			
203	532 44 13-43	Vent Side Hood LH			
204	532 44 13-75	Vent Top Hood			

NOTE: All component dimensions given in U.S. inches
1 inch = 25.4 mm

TRACTOR - - MODEL NO. CT153 (96051001501), PRODUCT NO. 960 51 00-15
DRIVE **40**

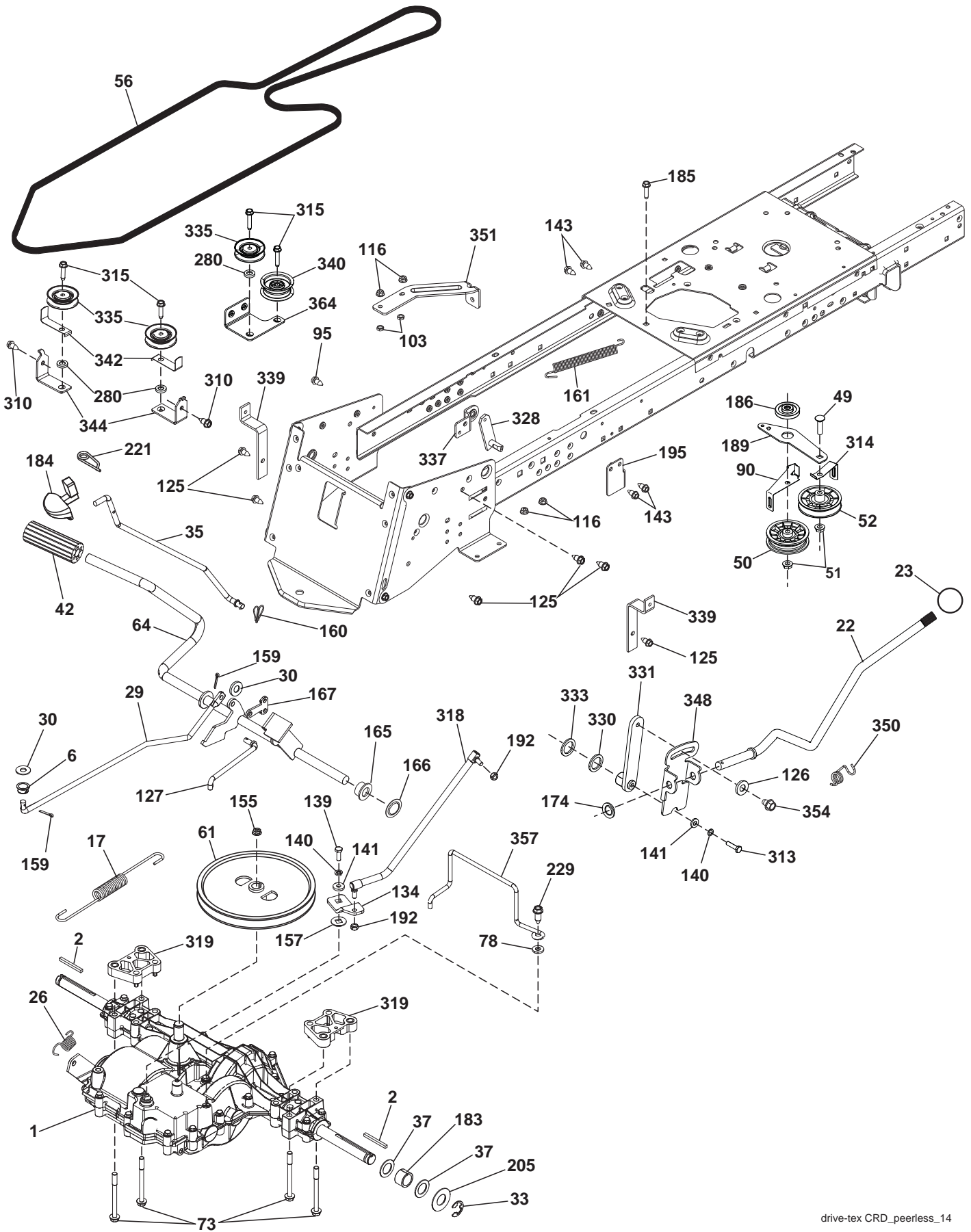

TRACTOR - - MODEL NO. CT153 (96051001501), PRODUCT NO. 960 51 00-15

DRIVE 40

KEY NO.	PART NO.	DESCRIPTION	KEY NO.	PART NO.	DESCRIPTION
1	- - - - -	Transaxle, Peerless 206-578 (436815)(Order parts from transaxle manufacturer.)	174	532 19 72-89	Nut Push
			183	532 13 70-57	Spacer Axle
			184	532 44 14-07	Handle Parking Brake
2	532 12 35-83	Key Square	185	872 11 06-22	Bolt
6	532 12 40-28	Bushing	186	532 19 43-21	Spacer Retainer
17	532 44 08-67	Spring, Brake	189	532 43 36-11	Bellcrank Ground Drive CRD Tex
22	532 44 32-46	Rod Shift CRD Tex	192	532 15 03-60	Nut Lock Center 1/4-28 Fnthd.
23	532 12 12-74	Knob Duckhead 1/2-13	195	532 43 58-65	Bracket Brake Rod
26	532 14 66-82	Spring Brake Return	205	532 12 17-48	Washer 25/32 x 1-5/8 16 Ga.
29	532 43 70-16	Rod, Brake	221	532 40 31-87	Retainer Spring Clip
30	819 13 16-16	Washer	229	817 06 05-16	Screw 5/16-18 x 1
33	812 00 00-01	Ring E	280	819 11 10-12	Washer
35	532 40 10-31	Rod, Brake, Park	310	817 49 06-08	Screw 3/8-16 x 1/2
37	532 12 17-49	Washer 25/32 x 1-1/4 x 16 Ga.	313	874 78 04-16	Bolt Hex Fin 1/4-20 x 1 Gr. 5
42	532 12 48-72	Cover, Foot Pedal	314	532 12 32-05	Retainer, Belt Style Spring
49	872 11 06-14	Bolt	315	817 58 05-20	Screw Thdrol 5/16-18 x 4.25
50	532 43 82-85	Idler Flat	318	532 43 70-22	Link Shift Gear
51	873 90 06-00	Lock Nut 3/8-16	319	532 43 67-94	Spacer Transaxle Tex CRD
52	532 19 43-26	Pulley Idler V Groove Plastic	328	532 43 79-58	Shaft Shift Front
56	532 43 63-84	V-Belt, Drive	330	532 16 95-93	Washer Nylon
61	532 16 59-99	Pulley Transaxle	331	532 44 36-06	Hub Shift
64	532 19 62-00	Shaft Asm. Pedal Brake Control	333	532 17 08-68	Wave Spring Washer
73	874 49 05-56	Bolt Flanged	335	532 19 95-34	Pulley V-Idler
78	819 11 12-12	Washer 11/32 x 3/4 x 12 Ga.	337	532 43 59-37	Bracket Supt Shift CRD Tex
90	532 44 36-05	Keeper Belt Clutching	339	532 43 68-67	Strap Torue K46 CRD Tex
95	817 00 06-12	Screw	340	532 43 68-12	Idler Flat
103	873 35 05-00	Nut	342	532 18 26-82	Keeper Belt
116	873 90 05-00	Nut Lock Hex Flange 5/16-18	344	532 43 56-45	Bracket Idler CRD Tex
125	817 00 05-12	Screw 5/16-18 x 3/4	348	532 44 36-07	Bracket Pivot Lever
126	532 16 60-02	Washer Srrtd 5/16 ID x 1.0 x .125	350	532 16 57-11	Spring Torsion Shift
127	532 19 43-23	Link Clutch Ground Drive	351	532 43 69-98	Bracket Deck Sway
134	532 14 50-90	Asm. Shift	354	817 49 05-10	Screw
139	874 55 04-12	Bolt 1/4-28 unf Gr. 8 w/Patch	357	532 44 13-38	Keeper Belt Trans.
140	810 04 04-00	Washer Lock Hvy. Helical 1/4	364	532 44 30-32	Bracket
141	819 09 12-10	Washer 9/32 x 3/4 x 10 Ga.			
143	817 49 05-08	Screw Thdrol 5/16-18 x 1/2 TYTT			
155	812 00 00-28	Ring Retainer			
157	532 10 57-01	Washer Plate Shift			
159	876 02 04-12	Cotter Pin			
160	532 16 94-84	Retainer Clip			
161	532 10 57-09	Spring, Return, Clutch			
165	532 19 62-12	Bushing Shaft Brake Hand Control			
166	532 42 91-64	Nut Push .625			
167	532 40 52-57	Latch Brake Parking			

NOTE: All component dimensions given in U.S. inches
1 inch = 25.4 mm

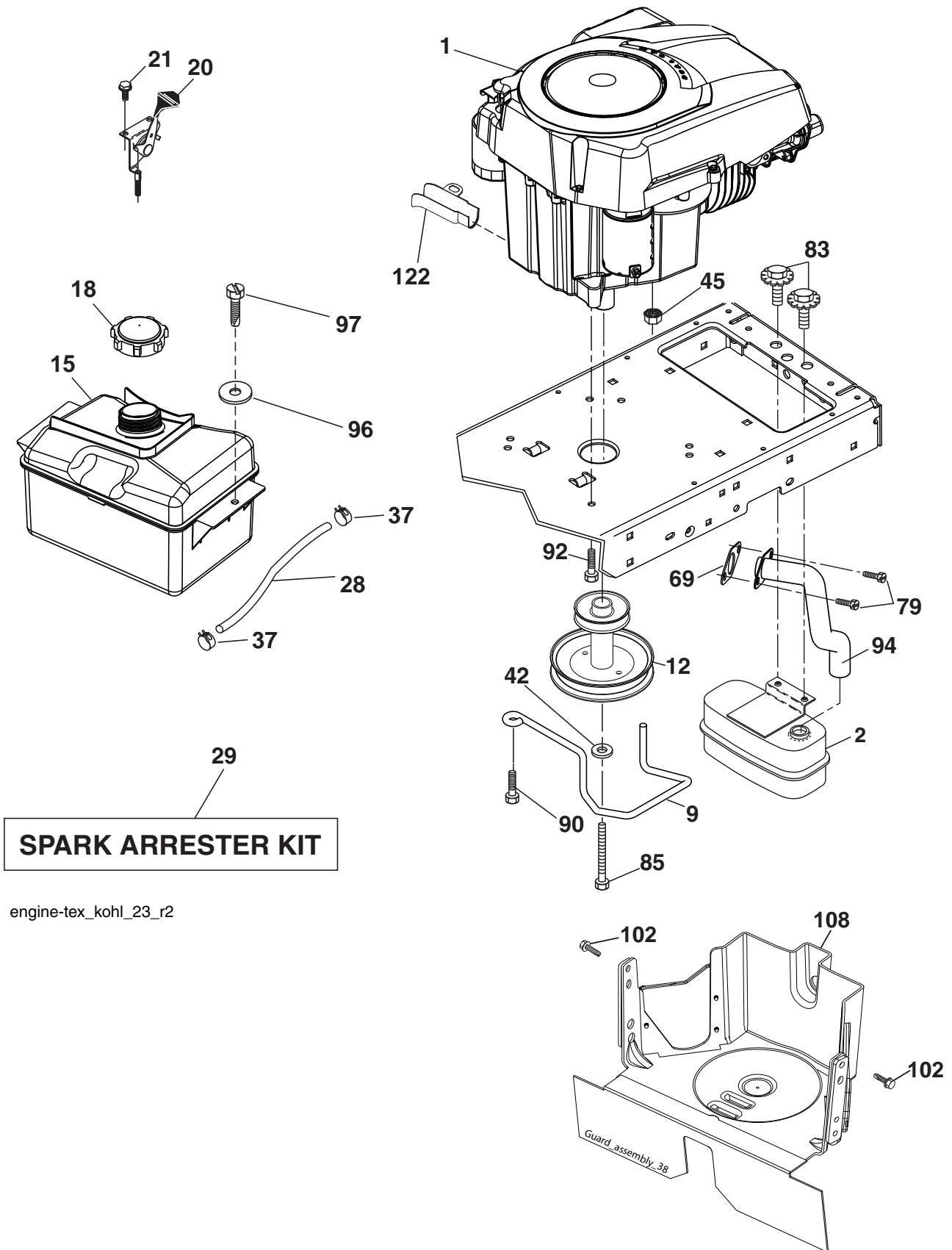

SPARK ARRESTER KIT

engine-tex_kohl_23_r2

**TRACTOR - - MODEL NO. CT153 (96051001501), PRODUCT NO. 960 51 00-15
ENGINE 24**

KEY NO.	PART NO.	DESCRIPTION
1	- - - - -	Engine Kohler Model No. SV470-3212 (438330)(Order parts from engine manufacturer.)
2	532 18 86-55	Muffler
9	532 19 43-20	Keeper Belt Engine
12	532 40 54-71	Pulley Engine
15	532 40 75-45	Tank Fuel 1.5
18	532 43 02-20	Cap Fuel
20	532 18 38-97	Control Throttle
21	532 41 63-58	Screw #10 x 0.750 BOS Thread
28	532 13 70-40	Fuel Line
29	532 13 71-80	Spark Arrester Kit
37	532 12 34-87	Clamp Hose
42	810 04 07-00	Lock Washer Hvy. 7/16
45	873 51 04-00	Nut Keps Hex 1/4-20 unc
69	532 18 59-09	Gasket
79	532 19 23-34	Screw Socket HD 5/16-18 x .75
83	532 17 18-77	Bolt 5/16-18 unc x 3/4 w/Sems.
85	532 17 39-37	Bolt Hex 7/16-20 x 4 x Gr. 5-1.5 Thr
90	817 00 06-16	Screw 3/8-16 x 1
92	817 12 06-16	Screw 3/8-16 x 1
94	532 18 86-54	Tube Exhaust
96	819 09 14-16	Washer 9/32 x 7/8 x 16 Ga.
97	817 67 04-12	Screw 1/4-20 x 3/4
102	817 06 05-16	Screw 5/16-18 x 1
108	532 42 30-41	Cover Pulley Engine
122	532 42 19-22	Extension Drain Oil

NOTE: All component dimensions given in U.S. inches
1 inch = 25.4 mm

TRACTOR - - MODEL NO. CT153 (96051001501), PRODUCT NO. 960 51 00-15
STEERING ASSEMBLY **41**

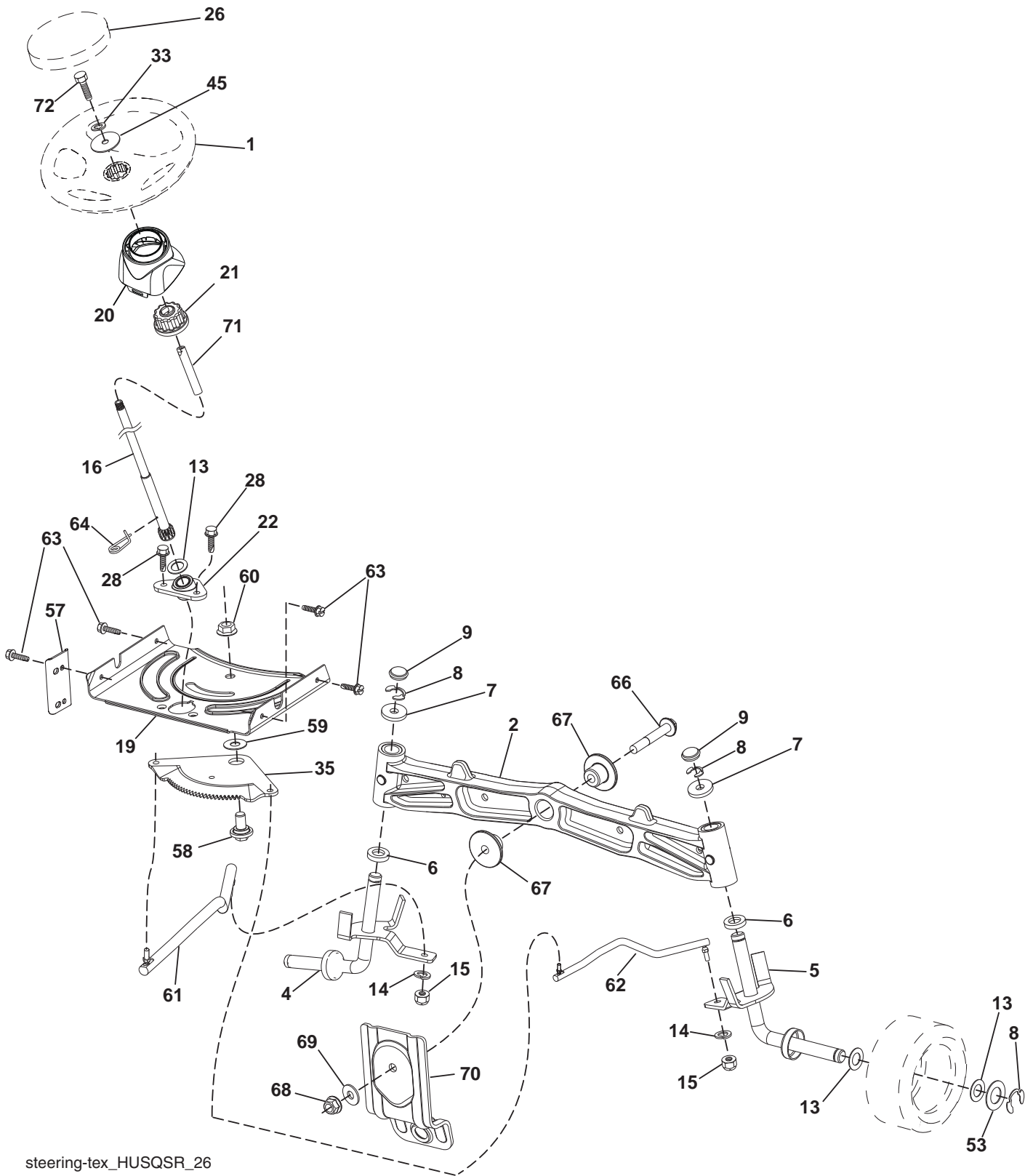

steering-tex_HUSQSR_26

TRACTOR - - MODEL NO. CT153 (96051001501), PRODUCT NO. 960 51 00-15
STEERING ASSEMBLY 41

KEY NO.	PART NO.	DESCRIPTION
1	532 43 97-40	Wheel, Steering Husq SR
2	532 19 59-68	Axle Asm., Front
4	532 40 30-87	Spindle Asm., LH
5	532 40 30-88	Spindle Asm., RH
6	532 12 49-31	Bearing, Race Thrust Hardened
7	532 12 17-48	Washer 25/32 x 1-5/8 x 16 Ga.
8	812 00 00-29	Ring, Clip #T5304-75
9	532 12 12-32	Cap, Spindle
13	532 12 17-49	Washer 25/32 x 1-1/4 x 16 Ga.
14	810 04 06-00	Washer, Lock Hvy. Hlcl. Spr. 3/8
15	873 54 06-00	Nut, Crown Lock 3/8-24 unf
16	532 42 93-73	Shaft Steering
19	532 19 47-29	Plate Steering
20	532 44 14-25	Boot, Steering
21	532 18 67-37	Adapter, Wheel Steering
22	532 42 05-37	Supt., Strg. Lower
26	532 43 97-43	Insert, Wheel Steering Husq SR
28	817 00 06-12	Screw 3/8-16 x 3/4
33	810 04 05-00	Washer Lock 5/16
35	532 19 47-32	Gear, Sector Plate
45	819 11 38-12	Washer 11/32 x 3/8 x 12 Ga.
53	532 18 89-67	Washer Hardened .793 x 1.637 x .060
57	532 40 74-65	Bracket Upstop
58	532 19 47-47	Bolt Shoulder Sector Pivot CFM
59	532 19 47-48	Washer Thrust Sector Steering
60	873 97 10-00	Nut Flange Lock 5/8-11
61	532 19 47-40	Draglink, LH
62	532 19 47-41	Draglink, RH
63	817 00 05-12	Screw 5/16-18 x 3/4
64	532 19 98-49	Retainer Clip Spring Steering
66	871 02 07-48	Bolt Hex Fghd. 7/16-14 x 3 Serr.
67	532 19 47-37	Bushing PM Front Axle
68	873 90 07-00	Nut Lock Flange 7/16-14 Gr. 5
69	532 19 91-62	Washer 1.5 x .505 x .118
70	532 19 61-97	Bracket Deck Susp. Front
71	532 19 07-52	Shaft Extension Steering
72	532 42 89-82	Bolt Fin Hx 5/16-18 x 4 w/Patch

NOTE: All component dimensions given in U.S. inches
1 inch = 25.4 mm

TRACTOR - - MODEL NO. CT153 (96051001501), PRODUCT NO. 960 51 00-15
 MOWER DECK **44**

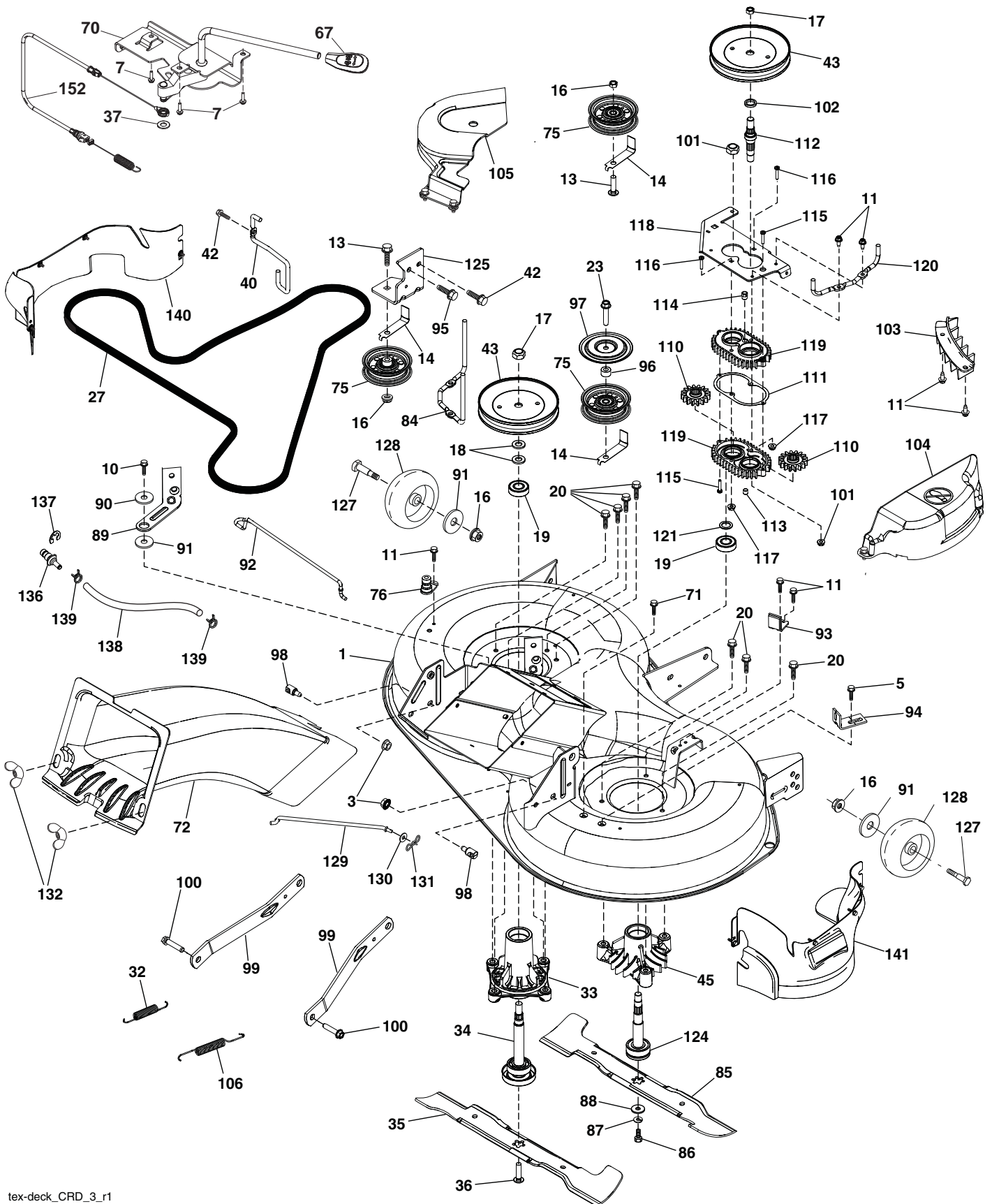

tex-deck_CRD_3_r1

TRACTOR - - MODEL NO. CT153 (96051001501), PRODUCT NO. 960 51 00-15
MOWER DECK 44

KEY NO.	PART NO.	DESCRIPTION	KEY NO.	PART NO.	DESCRIPTION
1	532 44 09-71	Deck Weldment	98	532 19 51-61	Stud Fastener
3	873 90 05-00	Nut Lock Hex Flange 5/16 - 18	99	532 19 51-86	Arm Suspension Mower Rear
5	817 00 05-10	Bolt 5/16-18	100	532 19 65-39	Bolt Shoulder
7	532 41 63-58	Screw #10 x 0.750 BOS Thread	101	873 68 09-00	Nut Crownlock 9/16 - 18 unc
10	817 00 06-16	Screw 3/8-16x1 smgml tap	102	532 40 25-11	Spacer Bearing Swing Plate
11	532 13 77-29	Screw Thd Roll 1/4 - 20 X 5/8	103	532 43 69-92	Guard Front Vent
13	872 11 06-12	Bolt Carr Sh 3/8 - 16 X 1 - 1/2 Gr. 5	104	532 43 89-68	Mandrel Cover RH
14	532 15 60-85	Keeper Belt Idler	105	532 43 87-44	Mandrel Cover LH
16	873 90 06-00	Nut Lock FIG 3/8 - 16 unc	106	532 19 32-16	Spring Brake Return
17	532 40 02-34	Nut Flange Lock Top	110	532 41 53-56	Gear Output
18	532 18 76-90	Washer Spacer Mandrel	111	532 43 69-79	Gasket Gearcase
19	532 11 04-85	Bearing Ball Mandrel	112	532 43 69-88	Shaft Gearcase
20	532 17 39-84	Screw Thread Roll	113	532 43 85-33	Plug Oil
23	817 49 06-28	Screw Thdrol 3/8 - 16 X 1-3/4	114	532 43 85-34	Valve Relief
27	532 43 97-26	V-Belt Drive	115	818 03 10-16	Screw Torx #10-24 x 1
32	532 40 18-72	Spring Return Deck	116	872 11 04-14	Bolt 1/4-20 x 1.75 Gr. 5
33	532 18 72-81	Housing Mandrel 4pt Service	117	873 90 04-00	Nut Hex Flange 1/4-20 unc
34	532 19 28-72	Shaft Asm Mndrl N/Greaseable38	118	532 43 69-89	Arm Clutching
35	532 42 79-84	Blade Mower LH	119	532 43 81-66	Gearcase Subasm
36	532 19 30-03	Bolt/Washer Asm 7/16 - 20 unf	120	532 43 69-91	Keeper Belt RH
37	819 13 13-16	Washer 13/32 x 13/16 x 16 Ga.	121	532 43 69-85	Washer
40	532 19 72-58	Keeper Belt Engine LH	124	532 43 69-86	Non Greasable Mandrel Shaft
42	817 00 05-12	Screw 5/16-18 x 3/4	125	532 43 69-94	Bracket Idler Chasses
43	532 19 74-73	Pulley Mandrel	127	532 19 34-06	Bolt Shoulder 3/8-16 x 3-5/8 Gr. 5
45	532 13 71-52	Housing Mandrel	128	532 17 48-73	Wheel Guage
67	532 40 30-12	Handle Clutch Cable	129	532 40 48-51	Rod Anti-Sway
70	532 40 12-46	Clutch Asm Manual LT Pred	130	819 13 13-12	Washer 13/32 x 13/16 x 12 Ga.
71	817 67 06-08	Screw Thdrol 3/8-16 x 1/2	131	532 19 42-08	Pin Cotter 5/16 Bow Tie Lock
72	532 43 66-58	Chute Upper	132	532 17 88-99	Knob Handle
75	532 13 14-94	Pulley Idler Flat	136	532 43 96-39	Washout Port Remote Hookup
76	532 43 96-40	Washout Port	137	812 00 00-29	Ring Klip
84	532 43 25-20	Keeper Belt LH Mandrel	138	532 44 07-43	Hose 3/8 Long 12"
85	532 42 79-85	Blade Mower RH	139	532 44 07-42	Clamp Hose 3/8
86	532 18 17-13	Bolt 3/8-24 x 1.50 Gr. 8	140	532 43 94-73	Guard Asm. LH
87	810 03 06-00	Washer Lock Hvy 3/8	141	532 44 85-29	Guard Asm. RH
88	532 14 02-96	Washer Hard Blade Mower Vented	152	532 44 04-88	Cable Clutch Manual w/Spring
89	532 43 81-24	Arm Brake 97 LH	--	532 19 28-70	Mandrel Assembly (Includes
90	532 19 90-92	Spacer Retainer			Housing, Shaft Assembly, And
91	819 13 20-12	Washer 13/32 x 1-1/4 x 12 Ga.			Bearing Only - Pulley/Nut/Washer
92	532 43 69-93	Rod Brake			And Blade Bolt/Washers Not
93	532 43 81-25	Arm Brake RH			Included)
94	532 19 72-50	Bracket Clutch Cable	--	532 44 11-29	Replacement Mower Complete
95	817 00 06-12	Screw 3/8-16 x 3/4			
96	532 40 02-71	Spacer			
97	532 18 20-61	Shield Idler Mower			

NOTE: All component dimensions given in U.S. inches
1 inch = 25.4 mm

TRACTOR - - MODEL NO. CT153 (96051001501), PRODUCT NO. 960 51 00-15
MOWER LIFT **45**

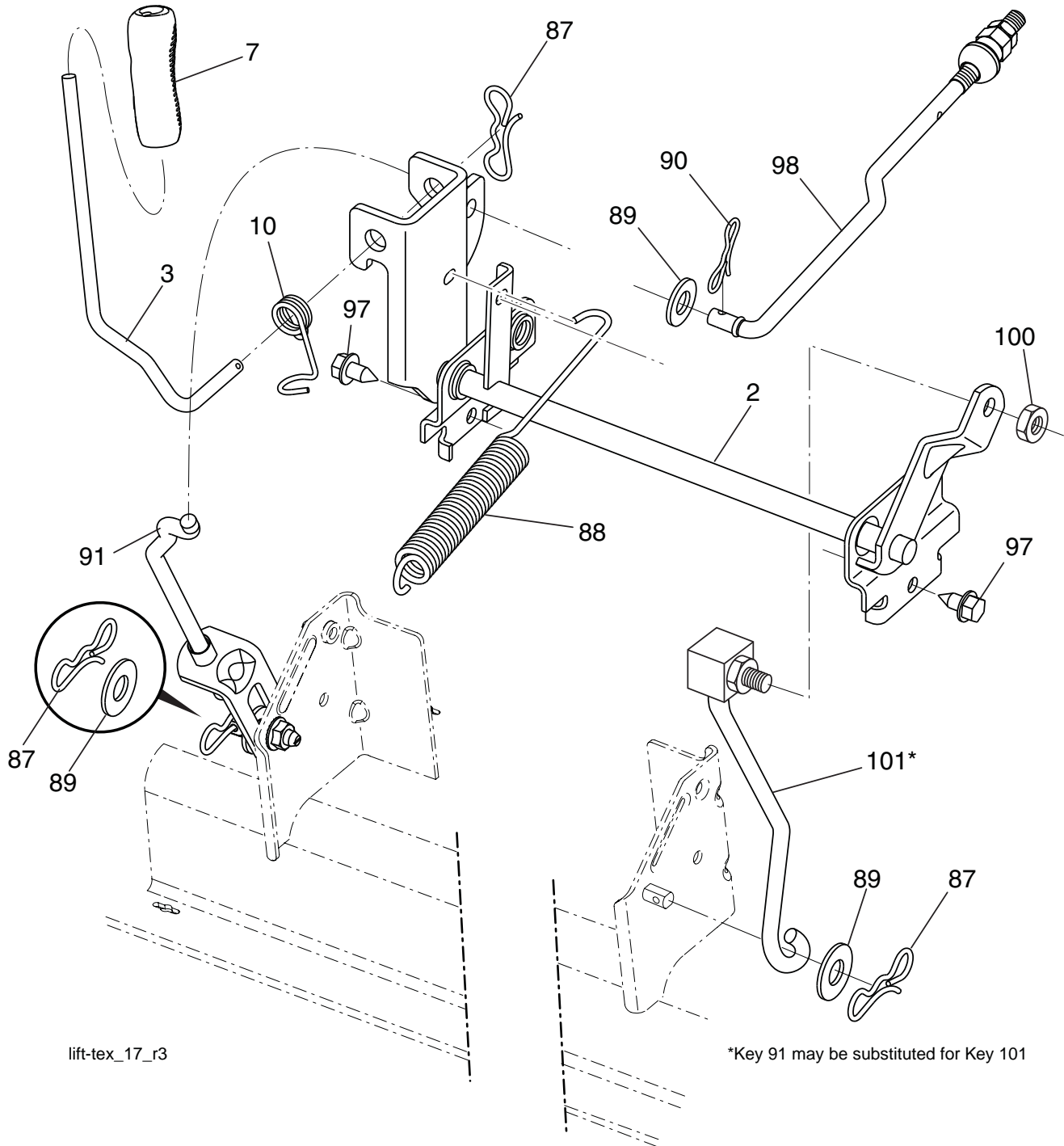

KEY NO.	PART NO.	DESCRIPTION
2	532 43 69-96	Deck Lift Weldment
3	532 19 52-31	Lever Asm., Lift RH
7	532 41 15-55	Grip, Lever
10	532 19 63-14	Spring Torsion
87	532 19 42-09	Pin Cotter 7/16 Bow Tie Lock
88	532 43 69-95	Spring Lift Assist
89	819 19 19-12	Washer Clear Zinc
90	532 19 42-08	Pin Cotter 5/16 Bow Tie Lock

KEY NO.	PART NO.	DESCRIPTION
91	532 19 51-81	Link Lift Susp. Mower Rear
97	817 49 06-08	Screw 3/8-16 x 1/2
98	532 19 52-70	Link Lift Susp. Front Mower
100	873 93 06-00	Nut Centerlock 3/8-16
101	532 40-70-03	Link Asm. Lift FXD

NOTE: All component dimensions given in U.S. inches
1 inch = 25.4 mm

**TRACTOR - - MODEL NO. CT153 (96051001501), PRODUCT NO. 960 51 00-15
SEAT ASSEMBLY 42**

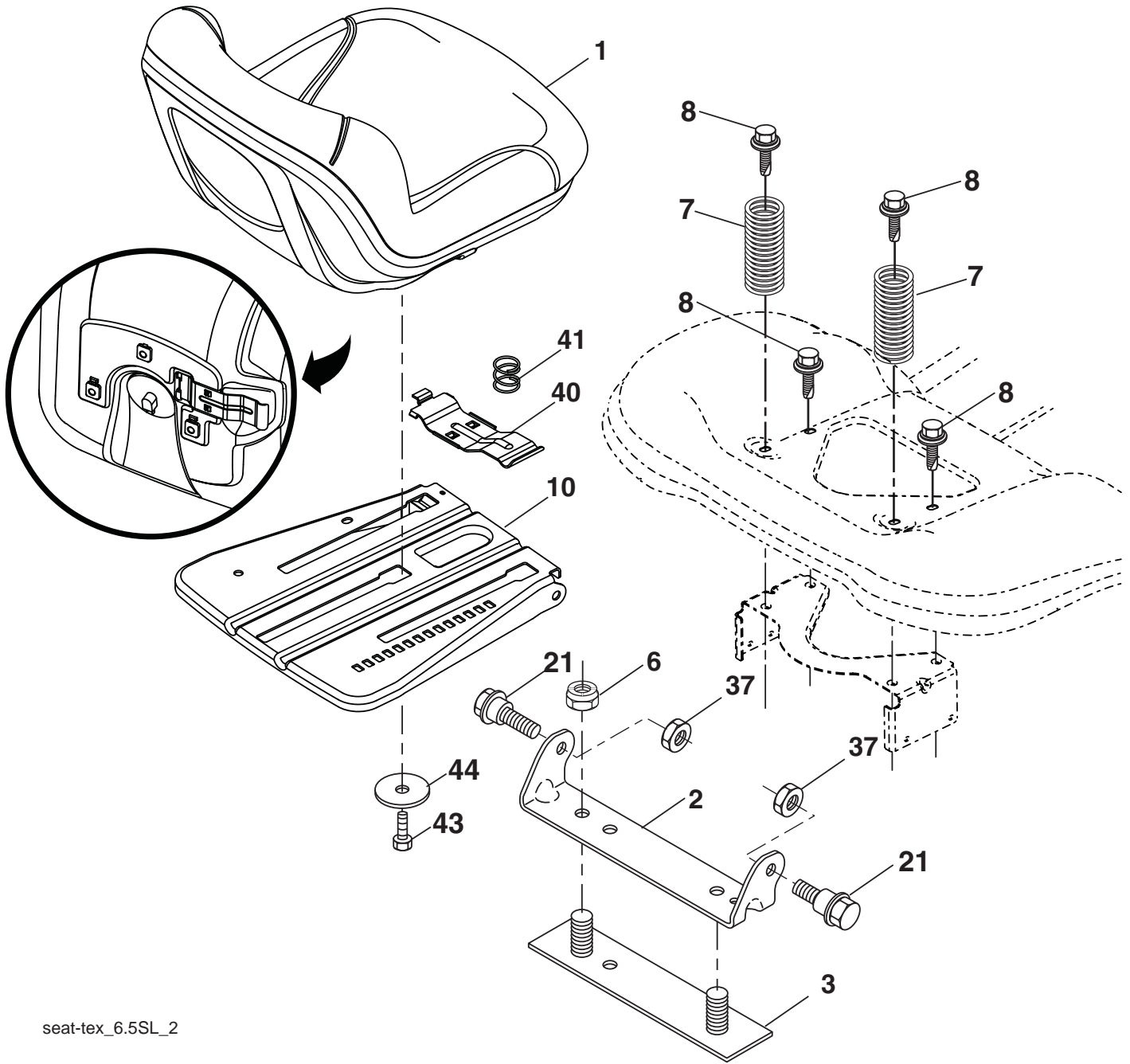

seat-tex_6.5SL_2

KEY NO.	PART NO.	DESCRIPTION
1	532 43 98-19	Seat
2	532 18 01-66	Bracket Pivot Fender
3	532 14 06-75	Strap, Asm. Fender
6	873 80 06-00	Nut, Lock w/Ins. 3/8-16 unc
7	532 12 41-81	Spring, Seat Cprsn.
8	532 17 18-77	Bolt 5/16-18 unc x 3/4 w/Sems.
10	532 19 69-77	Pan, Seat
21	532 17 18-52	Bolt, Shoulder 5/16-18

KEY NO.	PART NO.	DESCRIPTION
37	873 80 05-00	Nut, Lock 5/16-18 unc
40	532 19 76-61	Handle
41	532 19 82-00	Spring
43	874 76 06-12	Bolt 3/8-16 unc x 3/4
44	819 13 38-12	Washer 13/32 x 2-3/8 x 12 Ga.

NOTE: All component dimensions given in U.S. inches
1 inch = 25.4 mm

TRACTOR - - MODEL NO. CT153 (96051001501), PRODUCT NO. 960 51 00-15
BAGGER 46

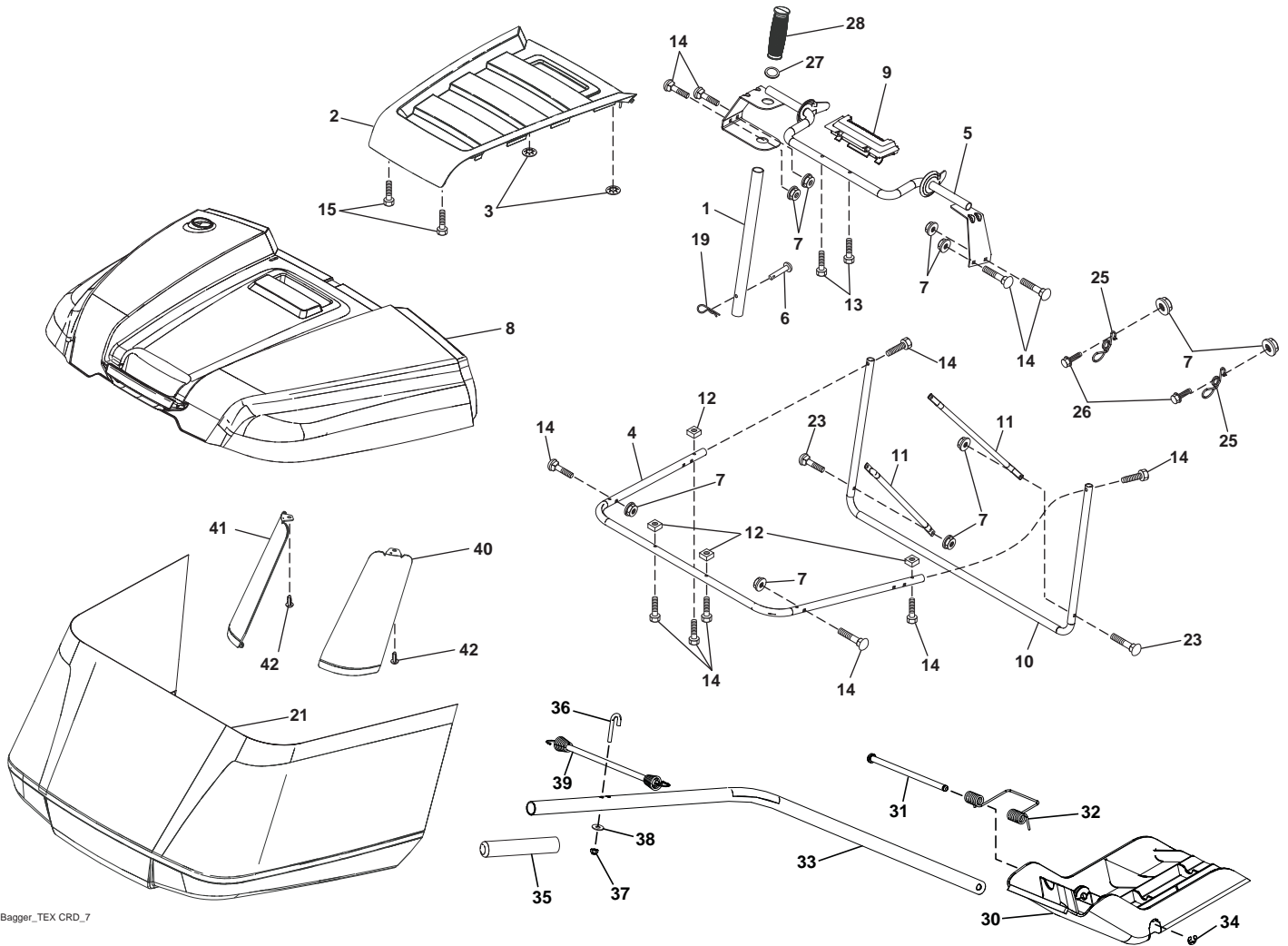

Bagger_TEX CRD_7

KEY NO.	PART NO.	DESCRIPTION
1	532 42 86-10	Tube Handle Bagger
2	532 44 13-58	Applique Top
3	532 41 38-08	Nut Push .156
4	532 43 96-12	Frame Asm Bagger Top
5	532 41 76-32	Frame Asm Top Bagger
6	532 12 68-75	Rivet Drilled
7	873 90 04-00	Nut Hex Flange 1/4-20 unc
8	532 44 12-61	Cover Bagger
9	532 41 76-29	Insert Handle Bagger
10	532 43 67-70	Frame Front
11	532 43 67-71	Tubing Brace Bagger
12	532 42 17-93	Nut Square 1/4
13	532 42 17-80	Screw 1/4 x 1.150
14	532 42 18-00	Bolt Shoulder 1/2 x 1.150
15	532 42 18-01	Screw #8
19	532 19 42-08	Cotter Pin 5/16 Bow Tie
21	532 43 81-62	Bag Asm
23	872 04 04-10	Bolt Carr. 1/4-20
25	532 42 16-14	Spring Latch Bagger

KEY NO.	PART NO.	DESCRIPTION
26	817 49 04-12	Screw Hexwsh Thdrl. 1/4-20 x 3/4
27	532 42 12-62	Grommet Rubber
28	532 16 57-87	Grip Handle Black
30	532 43 74-52	Plug
31	532 43 58-61	Pin Hinge
32	532 43 74-54	Spring Double Torsion
33	532 43 84-51	Shaft Mulch Plug
34	532 43 79-88	E-Ring 5/16
35	532 43 91-39	Grip Mulch Plug
36	532 43 90-98	Bolt J
37	532 06 91-80	Nut Lock #10-24 unc
38	819 07 08-18	Washer 7/32 x 1/2
39	532 43 92-42	Bungee
40	532 43 94-18	Support Bagger Corner RH
41	532 43 94-35	Support Bagger Corner LH
42	532 44 04-28	Christmas Tree Clip

NOTE: All component dimensions given in U.S. inches
 1 inch = 25.4 mm

