

CTH192

Spare parts

Ersatzteile

Pièces détachées

Reserve onderdelen

Repuestos

Reservdelar

ILLUSTRATED PARTS LIST

MFG. ID NO. 96061030900

CUSTOMER CATALOG NO. CTH192

PRODUCT NO. 960 61 03-09

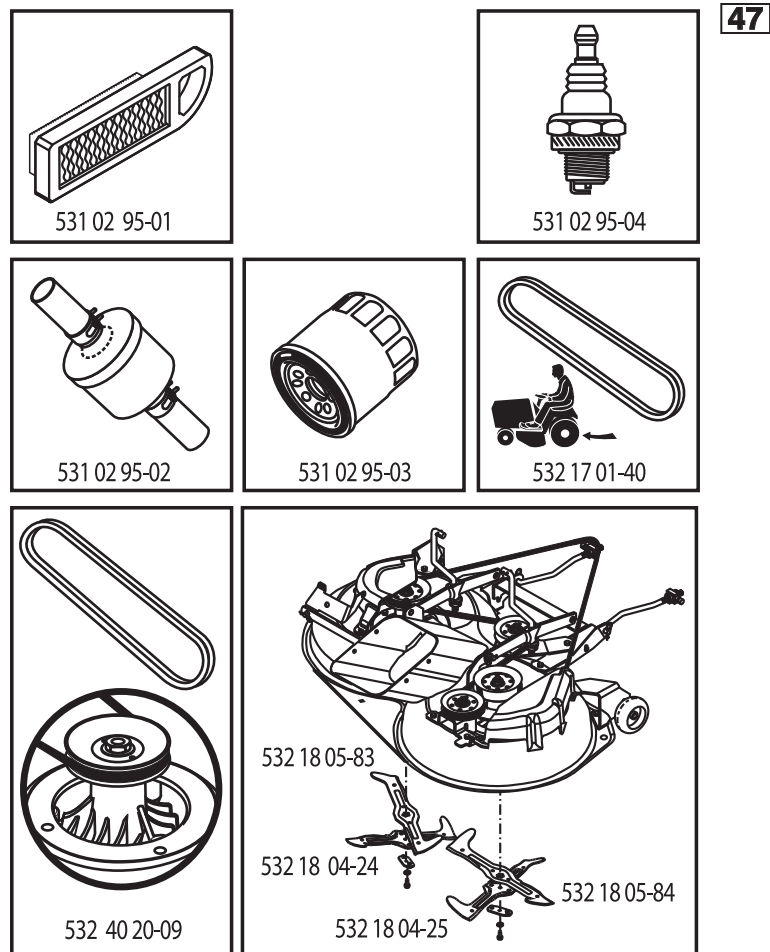

409725

**TRACTOR - - MODEL NO. CTH192 96061030900, PRODUCT NO. 960 61 03-09
DECALS 27**

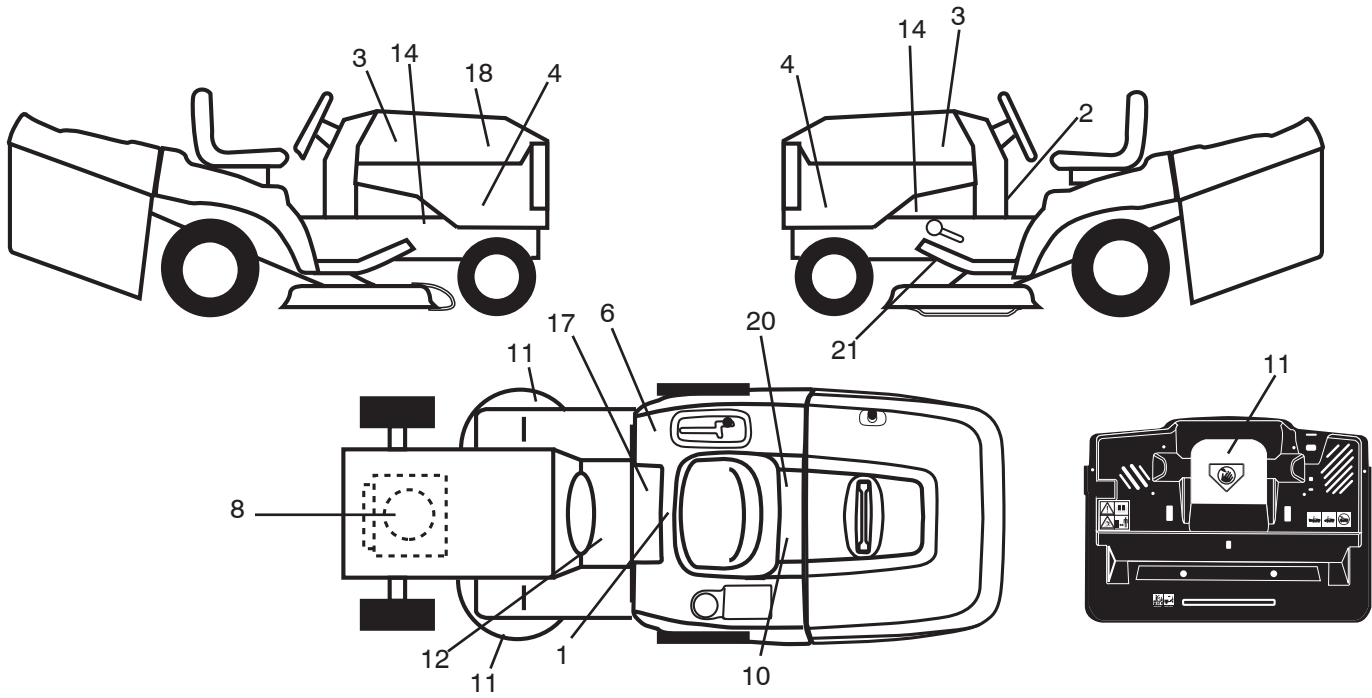

KEY NO.	PART NO.	DESCRIPTION
1	532 40 03-89	Decal Warning Symbols CE
2	532 44 02-48	Decal Instruction Mulch/BG
3	581 62 73-01	Decal Hood
4	532 44 05-53	Decal Hood Panel Side
6	532 18 04-32	Decal 100 DBA
8	532 19 68-41	Decal Warning Eng. Sym
10	532 14 50-05	Decal Bat Dan/Poi P/L Sym Wpn
11	532 18 21-66	Decal Mower Cut Finger Symbol
12	532 15 97-37	Decal Brake/Clutch Symbol Lt
14	532 15 97-36	Decal Chassis Hot Muffler
17	532 14 08-37	Decal Saddle Brake Parking

KEY NO.	PART NO.	DESCRIPTION
18	532 40 97-25	Decal Replacement
20	532 16 69-60	Decal Bypass Fender CRD
21	532 16 62-86	Decal Hex Belt Sch 92 CRD
--	532 13 83-11	Decal Handle Height Adjustment
--	532 44 14-94	Pad Footrest RH
--	532 44 06-48	Pad Footrest LH
--	532 44 10-31	Manual Operator's (Euro)
--	532 44 10-32	Manual Operator's (Scand)
--	532 44 10-33	Manual Operator's (E-bloc)
--	532 44 10-34	Manual Operator's (Baltic)

WHEELS & TIRES

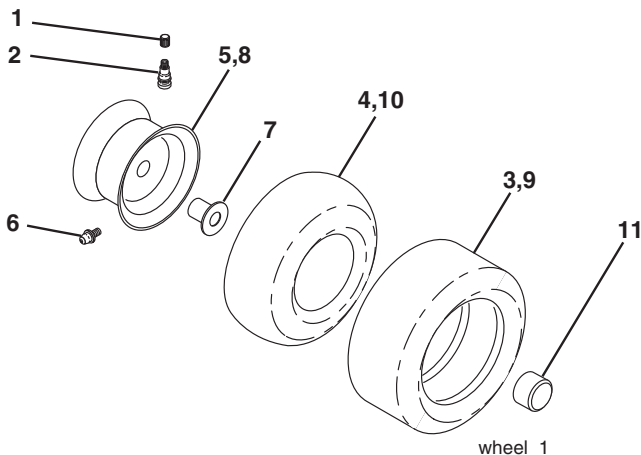

KEY NO.	PART NO.	DESCRIPTION
1	532 05 91-92	Cap Valve Tire
2	532 06 51-39	Stem Valve
3	532 10 62-22	Tire F Ts 15 x 6 0-6 Service
4	532 05 99-04	Tube Inner Front #35060
5	532 13 83-36	Rim Asm 6" Front Service
6	532 12 49-57	Fitting Grease
7	532 12 49-59	Bearing Flange
8	532 13 83-37	Rim Asm 8" Rear Service
9	532 12 20-82	Tire R Ts 20 x 10-8 Service
10	532 12 49-26	Tube Rear 9 5 x 8 Service
11	532 17 50-39	Cap Axle Blk 1 50 x 1 00
--	532 14 43-34	Sealant, Tire (10 oz. tube)

NOTE: All component dimensions given in U.S. inches
1 inch = 25.4 mm

TRACTOR - - MODEL NO. CTH192 96061030900, PRODUCT NO. 960 61 03-09
SCHEMATIC 38

SCH05

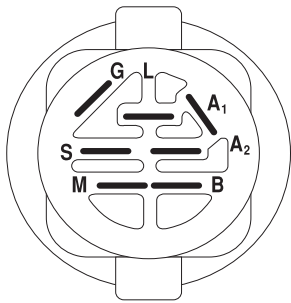
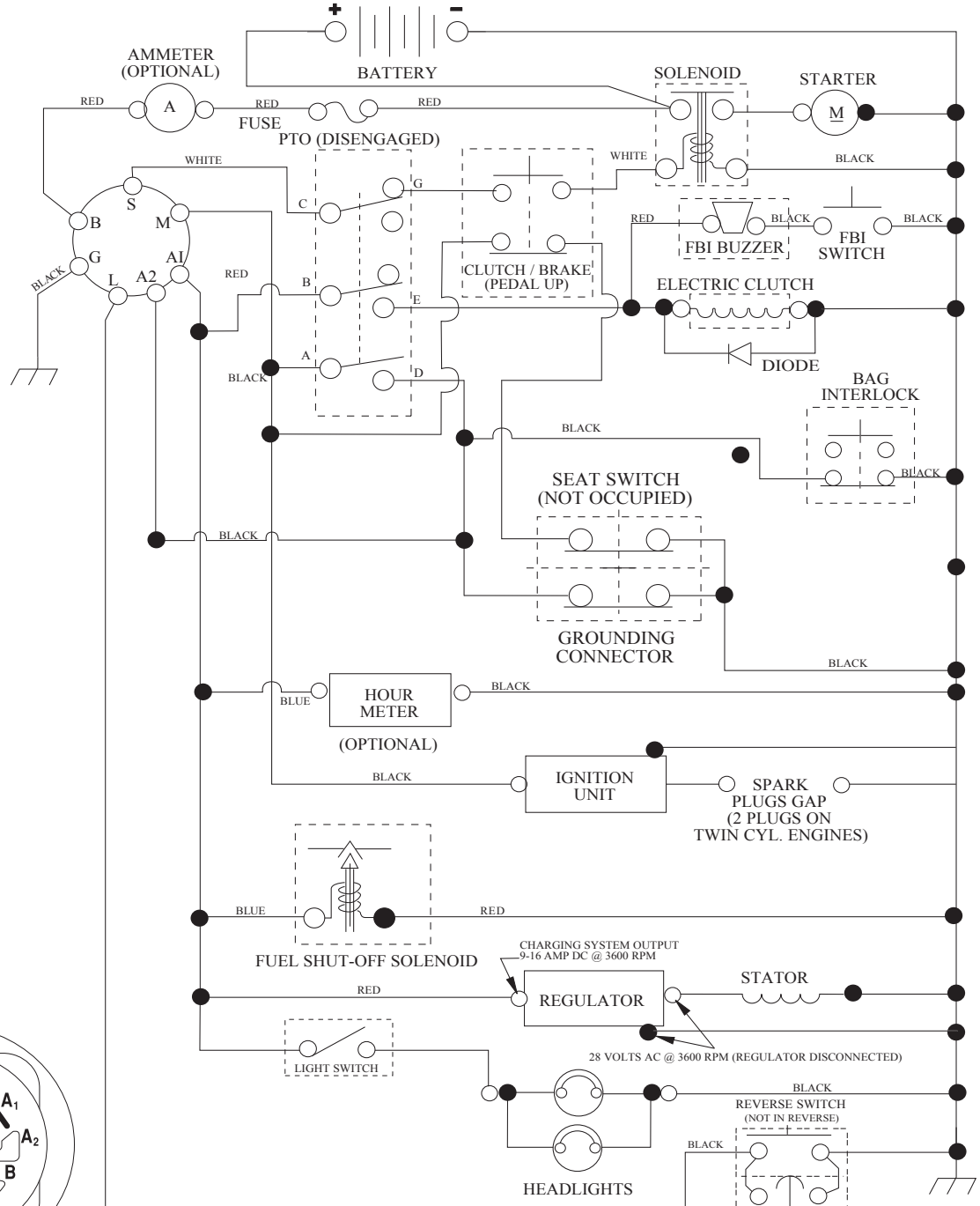

IGNITION SWITCH

POSITION	CIRCUIT "MAKE"
OFF	M+G+A1
RUN/OVERRIDE	B+A1
RUN	B+A1 L+A2
START	B + S + A1

WIRING INSULATED CLIPS
 NOTE: IF WIRING INSULATED CLIPS WERE REMOVED FOR SERVICING OF UNIT, THEY SHOULD BE RE-INSTALLED TO PROPERLY SECURE YOUR WIRING.

03048

PTO SWITCH

POSITION	CIRCUIT
OFF	C + G, B + H
ON	C + F, B + E, A + D

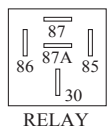

RELAY

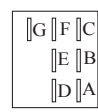

● NON-REMOVABLE CONNECTIONS

○ REMOVABLE CONNECTIONS

TRACTOR - - MODEL NO. CTH192 96061030900, PRODUCT NO. 960 61 03-09
 ELECTRICAL **32**

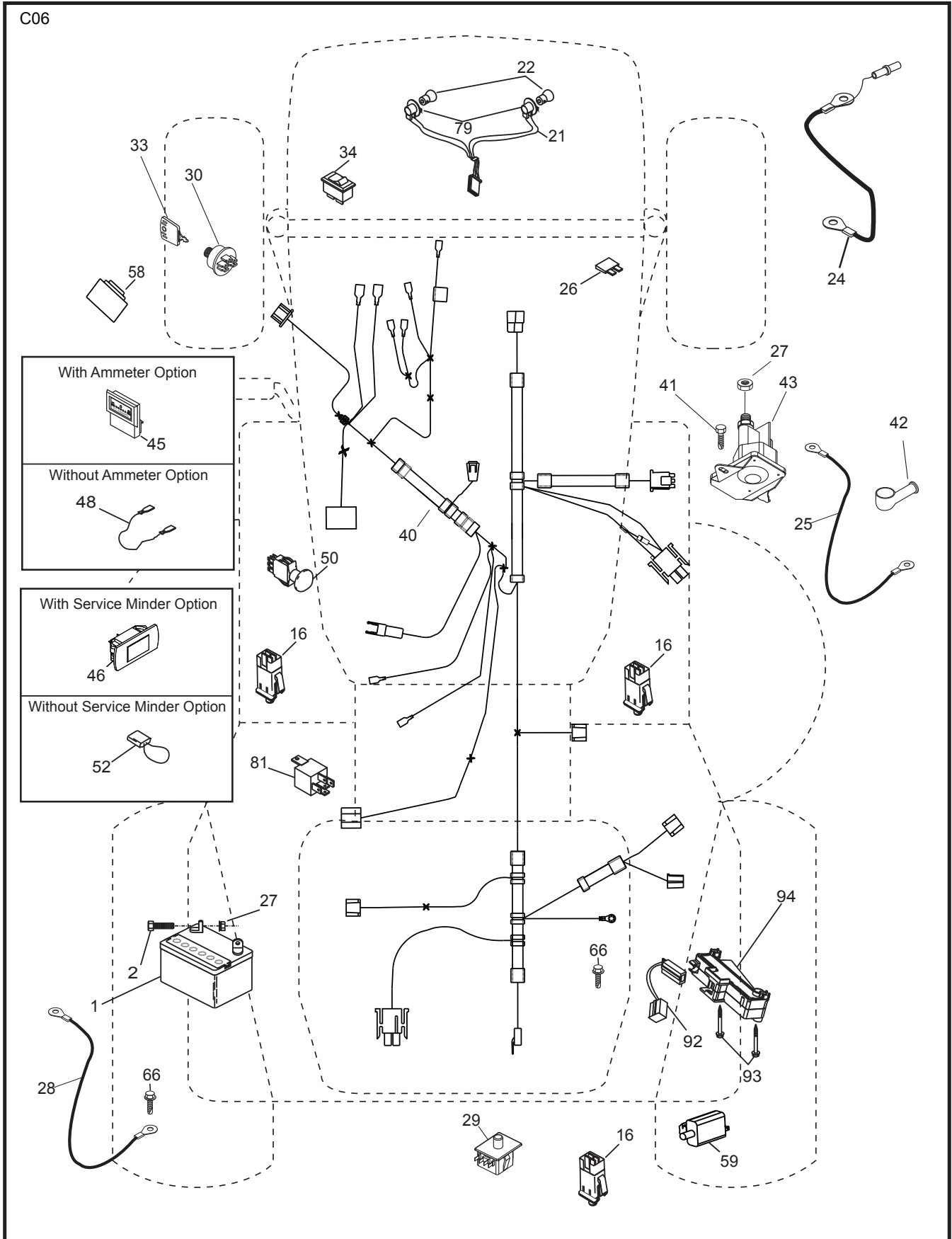

**TRACTOR - - MODEL NO. CTH192 96061030900, PRODUCT NO. 960 61 03-09
ELECTRICAL 32**

KEY NO.	PART NO.	DESCRIPTION
1	532 16 34-65	Battery
2	874 76 04-12	Bolt Hex Hd 1/4-20 unc x 3/4
16	532 17 61-38	Switch Interlock
21	532 40 02-52	Harness Asm Light w/4152J
22	532 00 41-52	Bulb Light #1156
24	532 16 59-87	Cable Battery CRD 56" Red
25	532 42 12-99	Cable Starter 6 Ga. 11" Red
26	532 17 51-58	Fuse
27	873 51 04-00	Nut Keps Hex 1/4-20 unc
28	532 12 77-25	Cable Ground 6 Ga. 18" Black
29	532 19 27-49	Switch Seat
30	532 19 33-50	Switch Ignition
33	532 41 19-35	Key/Chain
34	532 11 07-12	Switch Light
40	532 19 74-34	Harness Ign
41	871 11 04-08	Bolt Flk Fin Hex 1/4-20 unc x 1/2
42	532 13 15-63	Cover Terminal Red
43	532 19 25-07	Solenoid
46	532 41 39-31	Service Minder Hourmeter
48	532 14 08-44	Adapter Ammeter Rectangular
50	532 17 46-51	Switch PTO
58	532 16 94-19	Buzzer CRD
59	532 18 03-79	Switch FBI CRD
66	817 49 06-08	Screw Thdrol 3/8-16 x 1/2 Ty-Tt
79	532 17 52-42	Socket Asm. Bulb Twistlock
81	532 10 97-48	Relay Asm
92	532 19 66-15	Harness Pigtail
93	532 19 25-40	Screw Plastite 10-44 x 2.0
94	532 19 18-34	Module Reverse

NOTE: All component dimensions given in U.S. inches.
1 inch = 25.4 mm.

TRACTOR - - MODEL NO. CTH192 96061030900, PRODUCT NO. 960 61 03-09
CHASSIS AND ENCLOSURES **39**

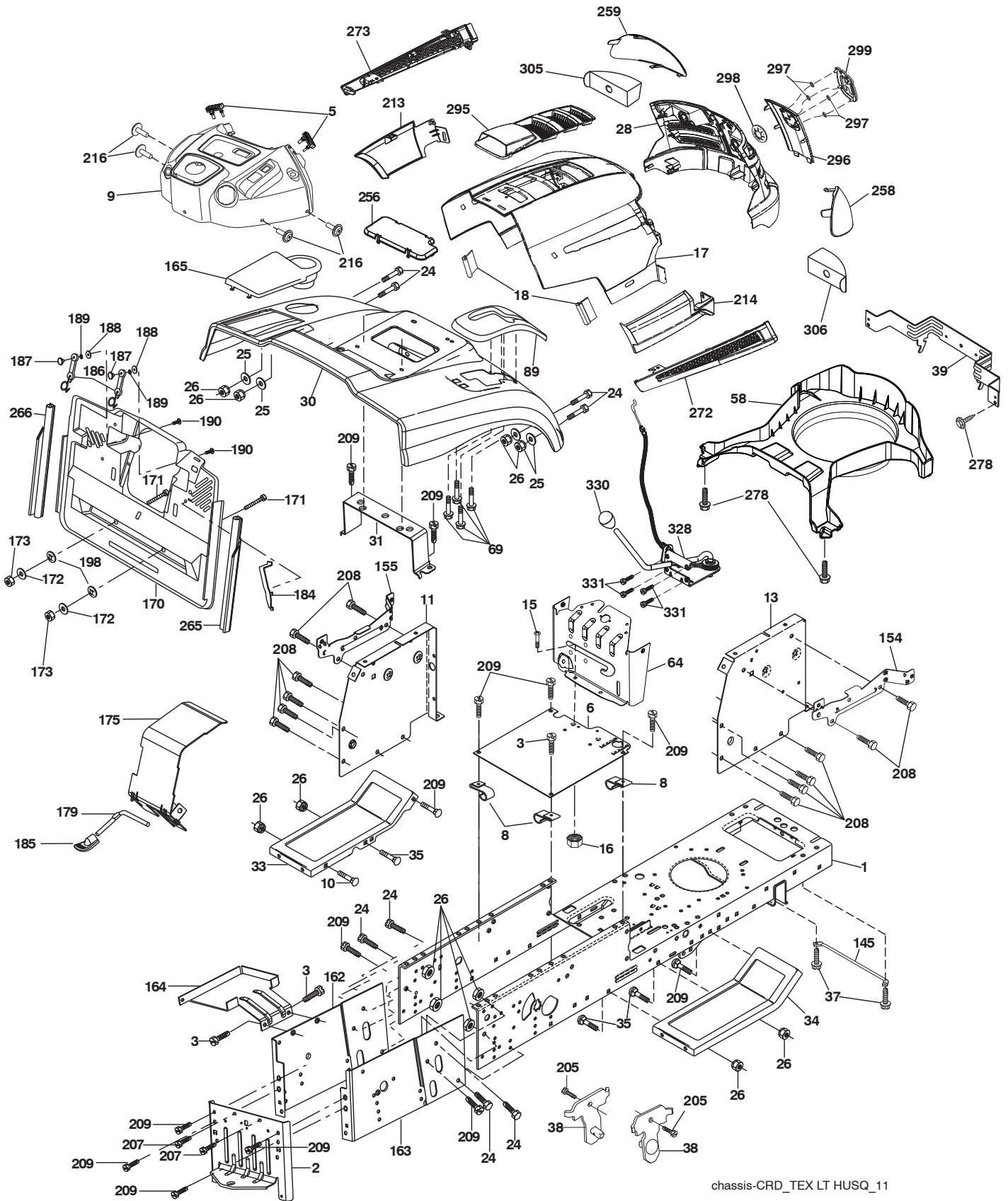

chassis-CRD_TEX LT HUSQ_11

**TRACTOR - - MODEL NO. CTH192 96061030900, PRODUCT NO. 960 61 03-09
CHASSIS AND ENCLOSURES 39**

KEY NO.	PART NO.	DESCRIPTION	KEY NO.	PART NO.	DESCRIPTION
1	532 17 46-20	Chassis	172	819 13 20-16	Washer 13/32 x 1-1/4 x 16 Ga.
2	532 18 03-84	Drawbar	173	873 51 06-00	Nut, Keps Hex 3/8-16 unc
3	817 06 06-12	Screw 3/8-16 x 3/4	175	532 18 82-03	Guard Trap
5	532 40 75-90	Bumper Dash	179	532 18 82-02	Rod Pivot FBI CRD
6	532 18 44-19	Saddle	184	532 17 46-62	Bracket Actuator Bagger CRD
8	532 12 64-71	Clip Insulator 13/32 Mtg. Hole	185	532 44 14-16	Knob Rod Brake Parking
9	532 44 06-03	Dash Asm Upper	186	532 16 07-93	Latch Asm Mulch/Bagger
10	872 14 06-08	Bolt, Carriage 3/8-16 x 3/4	187	532 12 50-04	Nut Weld
11	532 17 49-96	Panel, Dash, LH	188	819 06 12-16	Washer #10
13	532 17 21-06	Panel, Asm. Dash RH	189	810 07 10-00	Washer Lock #10
15	874 18 05-12	Screw Mach TRHD 5/16-18 unc x 3/4	190	871 08 10-10	Screw Pan Hd Phillip 10-24 x 5/8
16	873 51 05-00	Nut Keps 5/16-18 unc	198	532 16 89-37	Nut, Push
17	532 44 12-67	Hood	205	817 49 06-08	Screw Thdrol 3/8-16 x 1/2
18	532 40 47-42	Bumper Hood	207	817 67 05-08	Screw Thdrol 5/16-18 x 1/2
24	874 78 06-16	Bolt	208	817 67 06-08	Screw Thdrol 3/8-16-1/2
25	819 13 13-12	Washer 13/32 x 13/16 x 12 Ga.	209	817 00 06-12	Screw Hex Wsh Thdrol 3/8-16
26	873 80 06-00	Nut	213	532 44 13-45	Skirt Grille LH
28	532 42 69-63	Grille	214	532 44 13-44	Skirt Grille RH
30	532 44 12-65	Fender	216	817 67 04-12	Screw 1/4-20 x 3/4
31	532 16 51-56	Bracket, Fender Support	256	532 18 13-61	Cover Fender Rack
33	532 18 10-57	Footrest, LH	258	532 44 14-27	Lens RH
34	532 18 10-58	Footrest, RH	259	532 44 14-28	Lens LH
35	872 11 06-06	Bolt	265	532 18 57-04	Seal RH Side Bagger
37	817 49 05-08	Screw Thdrol 5/16-18 x 1/2 TYT	266	532 18 57-03	Seal LH Side Bagger
38	532 18 17-48	Bracket Asm Pivot Mower Rear	272	532 44 13-43	Vent Side Hood LH
39	532 40 78-07	Bracket Pivot Laser	273	532 44 13-42	Vent Side Hood RH
64	532 43 93-25	Dash Lower	278	532 41 63-58	Screw #10 x 0.750 BOS Thread
58	532 40 75-37	Duct Air	295	532 44 13-75	Vent Top Hood
69	532 14 24-32	Screw Hx Wsh Hi-Lo 1/4-1/2	296	532 44 13-74	Trim
89	532 44 15-74	Console CRD Auto	297	532 19 91-45	Clip Retainer
145	532 40 91-67	Rod Pivot Chassis/Hood	298	532 11 04-52	Nut Push
154	532 40 81-22	Bracket Dash RH	299	532 40 50-12	Logo
155	532 40 81-23	Bracket Dash LH	305	532 40 66-65	Insert Reflective LH
162	532 18 03-82	Bracket Exten Chassis LH CRD	306	532 41 65-01	Insert Reflective RH
163	532 18 03-83	Bracket Exten Chassis RH CRD	328	532 43 89-71	Control EZ Mulch
164	532 16 56-05	Support Battery CRD	330	532 44 06-39	Knob Oval
165	532 18 11-00	Cover Battery	331	532 40 07-76	Screw #10-24 x 5/8
170	532 19 94-88	Backplate CRD			
171	872 14 06-20	Bolt Rdhd Sqnk 3/8-16 x 2-1/Gr. 5			

NOTE: All component dimensions given in U.S. inches.
1 inch = 25.4 mm.

TRACTOR - - MODEL NO. CTH192 96061030900, PRODUCT NO. 960 61 03-09
DRIVE **40**

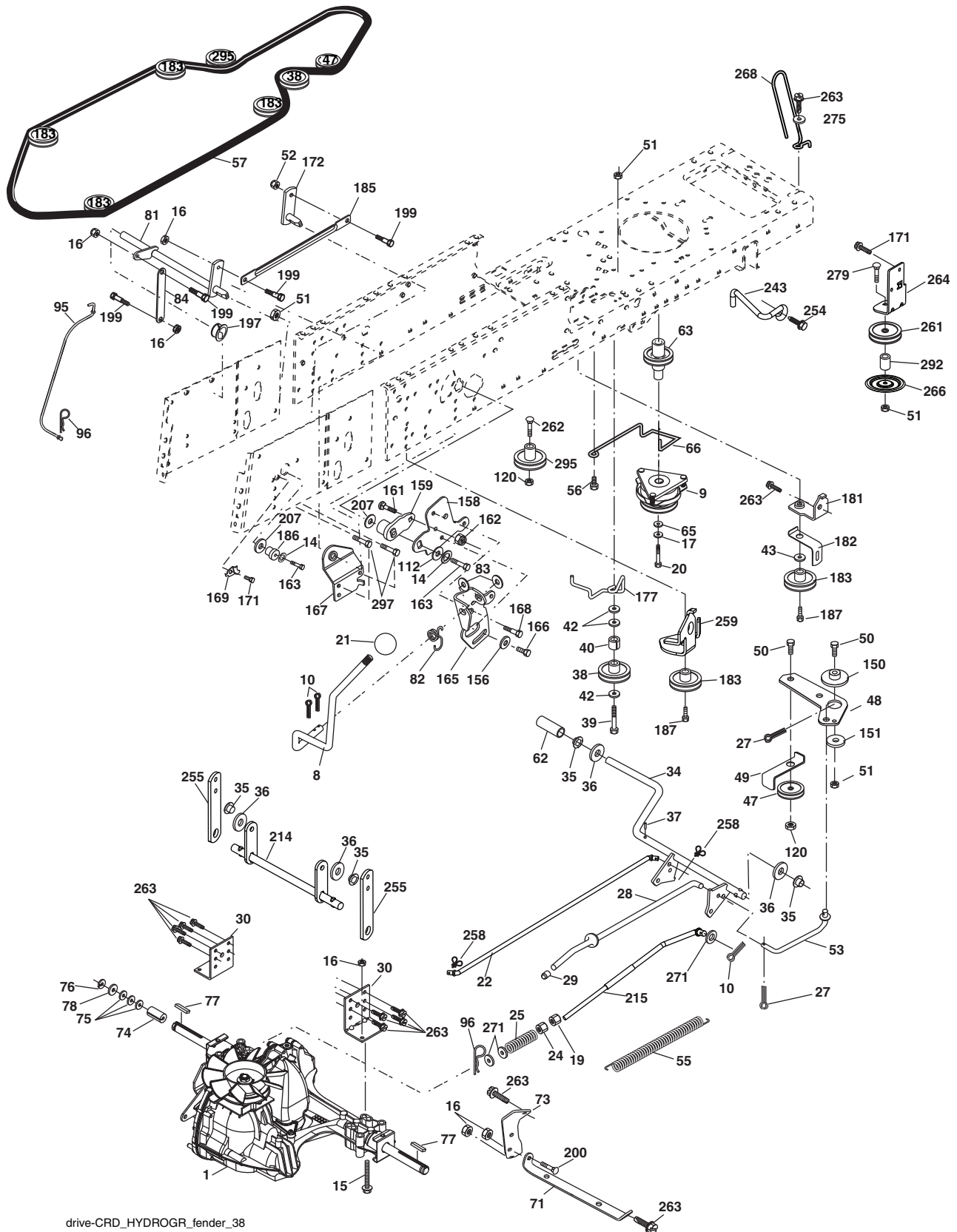

drive-CRD_HYDROGR_fender_38

TRACTOR - - MODEL NO. CTH192 96061030900, PRODUCT NO. 960 61 03-09
DRIVE 40

KEY NO.	PART NO.	DESCRIPTION	KEY NO.	PART NO.	DESCRIPTION
1	---	Transaxle Hydro Gear 321-0510 (Order parts from transaxle manufacturer.)	95	532 17 00-15	Control Asm Bypass Hydro
			96	532 12 47-88	Spring, Retainer 1"
8	532 19 27-06	Rod, Shift Fender Adjust Lt	112	819 09 12-10	Washer 9/32 x 3/4 x 10 Ga.
9	532 19 81-43	Clutch Asm OGURA	120	873 90 06-00	Nut Lock Flg. 3/8-16 unc
10	876 02 04-16	Pin, Cotter 1/8 x 1	150	532 16 58-50	Bushing, Bellcrank Grnd Dr
14	810 04 04-00	Washer, Lock Hvy Helical	151	819 13 32-10	Washer 13/32 x 2 x 10 Ga.
15	874 49 05-44	Bolt Hex FGHD 5/16-18 x Gr. 5	156	532 16 60-02	Washer Srrted 5/16 ID x 1.125
16	873 80 05-00	Nut Lock Hex w/lns 5/16-18 unc	158	532 43 74-58	Bracket Shift Mount
17	532 12 61-97	Washer 1-1/2 OD x 15/32 ID x .250	159	532 18 39-00	Hub Shift
19	873 80 06-00	Nut Lock Hex w/lns 3/8-16 unc	161	872 14 04-06	Bolt Rdhd Sqnk 1/4-20 x 3/4 Gr. 5
20	532 17 39-37	Bolt Hex 7/16-20x4xGr.5-1.5THR	162	873 68 04-00	Nut Crownlock 1/4-20 unc
21	532 12 12-74	Knob 1/2-13 unc Blk	163	874 78 04-16	Bolt Hex Fin 1/4-20 unc x 1 Gr. 5
22	532 17 56-07	Brake Rod Main	165	532 43 82-50	Bracket Pivot Lever
24	873 35 06-00	Nut Hex Jam 3/8-16 unc	166	817 49 05-10	Screw 5/16-18 x 5/8
25	532 19 20-36	Spring, Rod, Brake	167	532 16 55-88	Bracket Support Shift CRD
27	876 02 04-12	Pin, Cotter 1/8 x 3/4	168	532 16 54-92	Bolt Shoulder 5/16-18 x .561
28	532 17 57-65	Rod, Parking Brake	169	532 16 55-80	Plate Fastening Lt
29	532 44 14-96	Cap, Parking Brake	171	817 49 06-08	Screw Thdrol 3/8-16 x 1/2 Ty-Tt
30	532 16 95-92	Bracket, Mfg. Transaxle	172	532 17 02-71	Shaft Asm Shifter Frt CRD
34	532 17 55-78	Shaft, Asm Pedal Foot CRD	177	532 16 59-32	Keeper Flat Idler 3.06" CRD
35	532 12 01-83	Bearing, Nylon	181	532 18 02-11	Bracket Idler Ground Drive CRD
36	819 21 16-16	Washer 21/32 x 1 x 16 Ga.	182	532 18 26-82	Keeper Belt 2.5" Od V-Idler CRD
37	532 12 49-63	Pin, Roll 3/16 x 1"	183	532 19 95-34	Pulley V-Idler 2.50" Od CRD
38	532 16 59-36	Pulley Flat Composite 3.06"	185	532 17 00-08	Link Shift
39	874 76 06-44	Bolt Fin Hex 3/8-16 unc x 2-3/4	186	532 16 56-14	Hub Tapered Round CRD
40	532 12 49-65	Spacer, Split 395 x 59 Bzp	187	817 58 05-20	Screw Thdrol 5/16-18 x 1.25
42	819 13 13-12	Washer 13/32 x 13/16 x 12 Ga.	197	532 16 96-13	Nyliner Snap-In 5/8
43	819 11 10-12	Washer 11/32 x 5/8 x 12 Ga.	199	532 16 96-12	Bolt Shoulder 5/16-18 unc
47	532 12 77-83	Pulley, Idler, V Groove Plastic	200	872 14 05-08	Bolt RDHD SQNK 5/16-18 x 1
48	532 15 44-07	Bellcrank Clutch Grnd Drv	207	532 16 98-45	Washer Nylon Rear
49	532 12 32-05	Retainer, Belt Style Spring	214	532 17 56-09	Shaft Asm. Brake
50	872 11 06-12	Bolt Carr. Sh. 3/8-16 x 1-1/2 Gr. 5	215	532 17 56-52	Rod Brake Hydro
51	873 68 06-00	Nut, Crownlock 3/8-16 unc	243	532 19 07-36	Bracket Anti-Rotation
52	873 68 05-00	Nut, Crownlock 5/16-18	254	817 00 06-16	Screw 3/8-16 x 1
53	532 19 96-52	Link, Clutch 7.66	255	532 17 56-08	Brace Shaft Brake Mtg.
55	532 10 57-09	Spring, Return, Clutch	258	532 17 80-62	Clip Retainer
56	817 06 06-20	Screw 3/8-16 x 1-1/4	259	532 18 02-12	Bracket Pulley
57	532 17 01-40	V-Belt Kev 112" 0650 CRD	260	532 43 11-72	Bracket Idler Chassis
62	532 12 48-72	Cover, Pedal	261	532 13 14-94	Pulley Idler
63	532 18 03-97	Pulley Engine	262	872 11 06-22	Bolt Carr. 3/8-16 x 2-3/4 Gr. 5
65	810 04 07-00	Washer	263	817 00 06-12	Screw 3/8-16 x 3/4
66	532 15 47-78	Keeper, Belt Engine F-Proof	264	532 43 11-72	Bracket Idler Chassis
71	532 16 91-83	Strap, Torque, LH	266	532 18 20-61	Shield Idler Mower
73	532 16 91-82	Strap, Torque, RH	268	532 18 24-02	Muffler Guard
74	532 13 70-57	Spacer, Split	271	819 13 14-16	Washer 13/32 x 7/8 x 16 Ga.
75	532 12 17-49	Washer 25/32 x 1-1/4 x 16 Ga.	275	819 13 16-14	Washer 13/32 x 1 x 14 Ga.
76	812 00 00-01	Ring, E	279	872 11 06-16	Bolt 3/8-16 x 2
77	532 12 35-83	Key, Square	292	532 40 02-71	Spacer Idler Chassis
78	532 12 17-48	Washer 25/32 x 1-5/8 x 16 Ga.	295	532 17 91-14	Pulley Idler Composite
81	532 17 00-06	Asm, Shaft, Cross Rear	297	817 49 06-10	Screw 3/8-16 x 5/8
82	532 16 57-11	Spring, Torsion			
83	819 17 12-16	Washer 17/32 x 3/4 x 16 Ga.			
84	532 17 00-07	Link, Transaxle			

NOTE: All component dimensions given in U.S. inches
1 inch = 25.4 mm

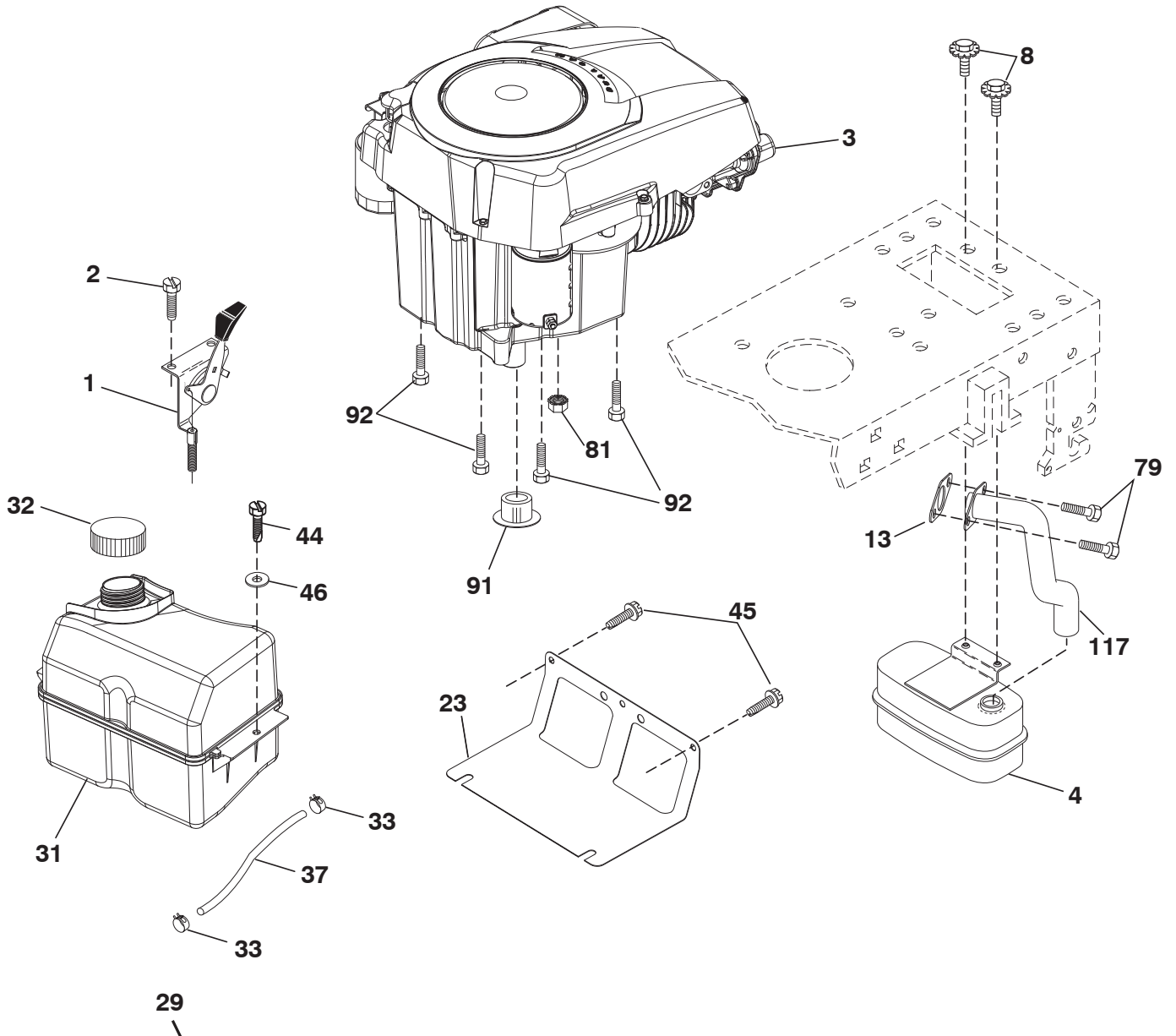

OPTIONAL EQUIPMENT
Spark Arrester

engine-CRD_Kohl_12_r1

**TRACTOR - - MODEL NO. CTH192 96061030900, PRODUCT NO. 960 61 03-09
ENGINE 24**

KEY NO.	PART NO.	DESCRIPTION
1	532 18 38-97	Control Throt/Ch Flag
2	532 41 63-58	Screw #10 x 0.750 BOS Thread
3	- - - - -	Engine Kohler SV590-0210 (Order parts from engine manufacturer.)
4	532 18 86-55	Muffler
8	532 17 18-77	Bolt 5/16-18 x 3/4
13	532 18 59-09	Gasket
23	532 16 98-37	Shield Browning/Debris Guard
29	532 13 71-80	Arrestor Spark
31	532 40 75-45	Tank Fuel
32	532 43 02-20	Cap Asm Fuel
33	532 12 34-87	Clamp Hose Blk
37	532 13 70-40	Line Fuel 20"
44	817 67 04-12	Screw Hexwsh Thdrol 1/4-20 x 3/4
45	817 00 06-12	Screw Hexwsh Thdr 3/8-16 x 3/4
46	819 09 14-16	Washer 9/32 x 7/8 x 16 Ga.
79	532 19 23-34	Screw, Socket HD 5/16-18 x .75
81	873 51 04-00	Nut Keps 1/4-20 unc
91	532 18 74-95	Bushing 1.375 OD
92	817 12 06-16	Screw 3/8-16 x 1
117	532 18 86-54	Tube Exhaust

NOTE: All component dimensions given in U.S. inches.
1 inch = 25.4 mm.

TRACTOR - - MODEL NO. CTH192 96061030900, PRODUCT NO. 960 61 03-09
 STEERING ASSEMBLY **41**

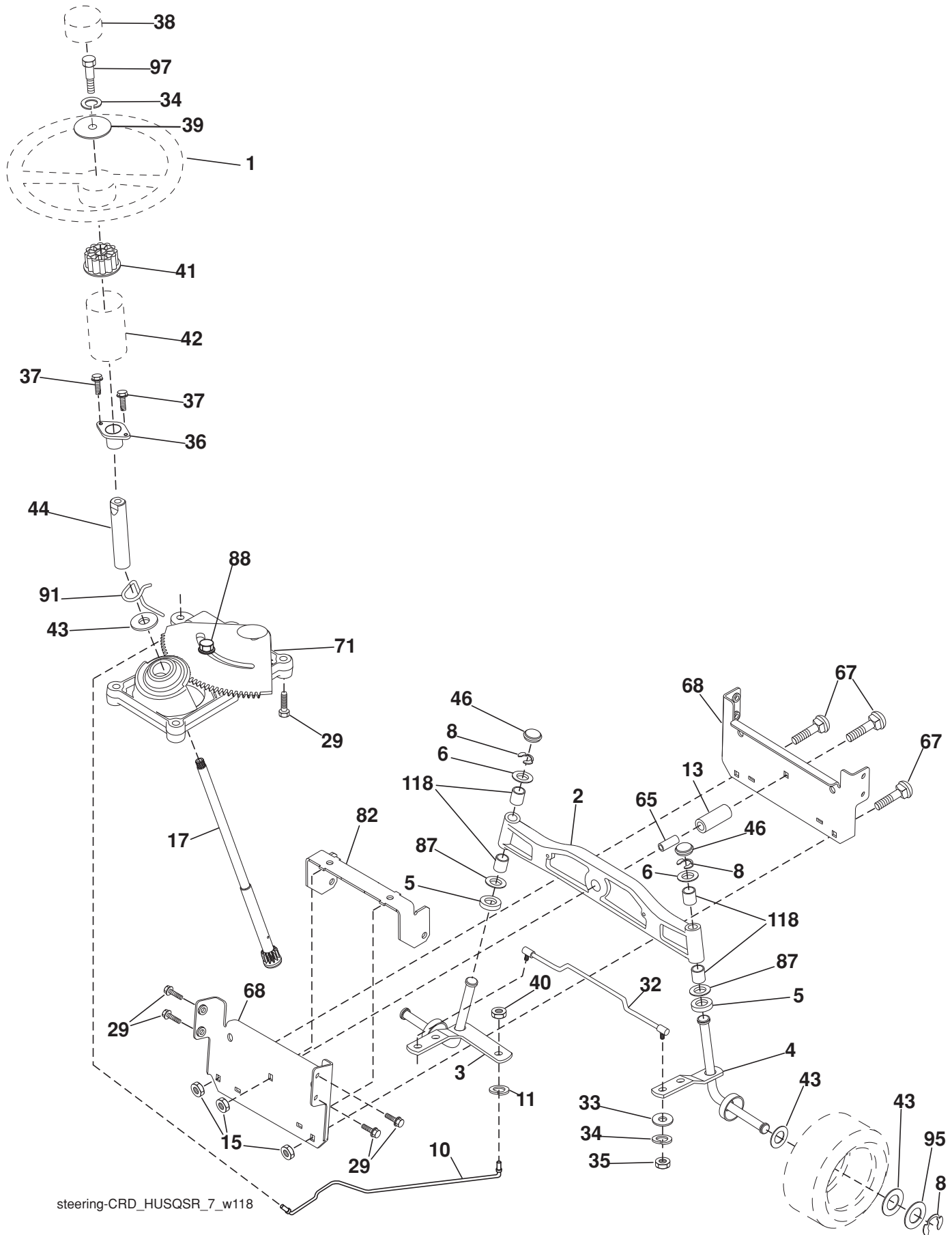

steering-CRD_HUSQSR_7_w118

**TRACTOR - - MODEL NO. CTH192 96061030900, PRODUCT NO. 960 61 03-09
STEERING ASSEMBLY 41**

KEY NO.	PART NO.	DESCRIPTION
1	532 43 97-40	Steering Wheel
2	532 19 35-42	Front Axle Assembly
3	532 16 98-40	Spindle Assembly, LH
4	532 16 98-39	Spindle Assembly, RH
5	532 12 49-31	Bearing, Race, Thrust, Hardened
6	532 12 17-48	Washer 25/32 x 1-5/8 x 16 Ga.
8	812 00 00-29	Ring, Clip
10	532 17 51-21	Link, Drag
11	810 04 06-00	Washer, Lock
13	532 13 65-18	Spacer Axle
15	873 90 06-00	Nut Flange Lock
17	532 19 07-53	Shaft Assembly, Steering
29	817 00 06-12	Screw 3/8-16 x 3/4
32	532 17 18-88	Rod, Tie
33	819 11 12-16	Washer 11/32 x 3/4 x 16 Ga.
34	810 04 05-00	Washer Lock Hvy Hlcl Spr 5/16
35	873 54 05-00	Crownlock Nut 5/16-24 unf
36	532 15 50-99	Bushing, Steering
37	532 15 29-27	Screw TT #10-32 x 5 x 3/8 Flange
38	532 43 97-43	Cap Wheel Steering
39	819 11 38-12	Washer 11/32 ID x 2-3/8 OD x 12 Ga.
40	873 54 06-00	Nut Crownlock 3/8-24
41	532 18 67-37	Adaptor, Steering Wheel
42	532 44 14-25	Boot, Steering Dash P/L Mtl
43	532 12 17-49	Washer 25/32 x 1-1/4 x 16 Ga.
44	532 19 07-52	Shaft Exten. Strg. Spline
46	532 12 12-32	Cap, Spindle
65	532 41 47-36	Spacer Brace Axle
67	872 11 06-18	Bolt Rdhd Sq 3/8-16 x 2-1/4
68	532 16 98-27	Brace Axle
71	532 17 51-46	Steering Asm.
82	532 19 99-78	Bracket Susp. Chassis Front
87	532 17 39-66	Washer Flat .781 x 1-1/2 x .14
88	532 17 51-18	Bolt Shoulder 7/16-20 unc
91	532 17 55-53	Clip Steering
95	532 18 89-67	Washer
97	532 42 89-82	Bolt 5/16-18 x 4" w/Patch
118	532 40 60-13	Bushing

NOTE: All component dimensions given in U.S. inches.
1 inch = 25.4 mm.

TRACTOR - - MODEL NO. CTH192 96061030900, PRODUCT NO. 960 61 03-09
 MOWER DECK **44**

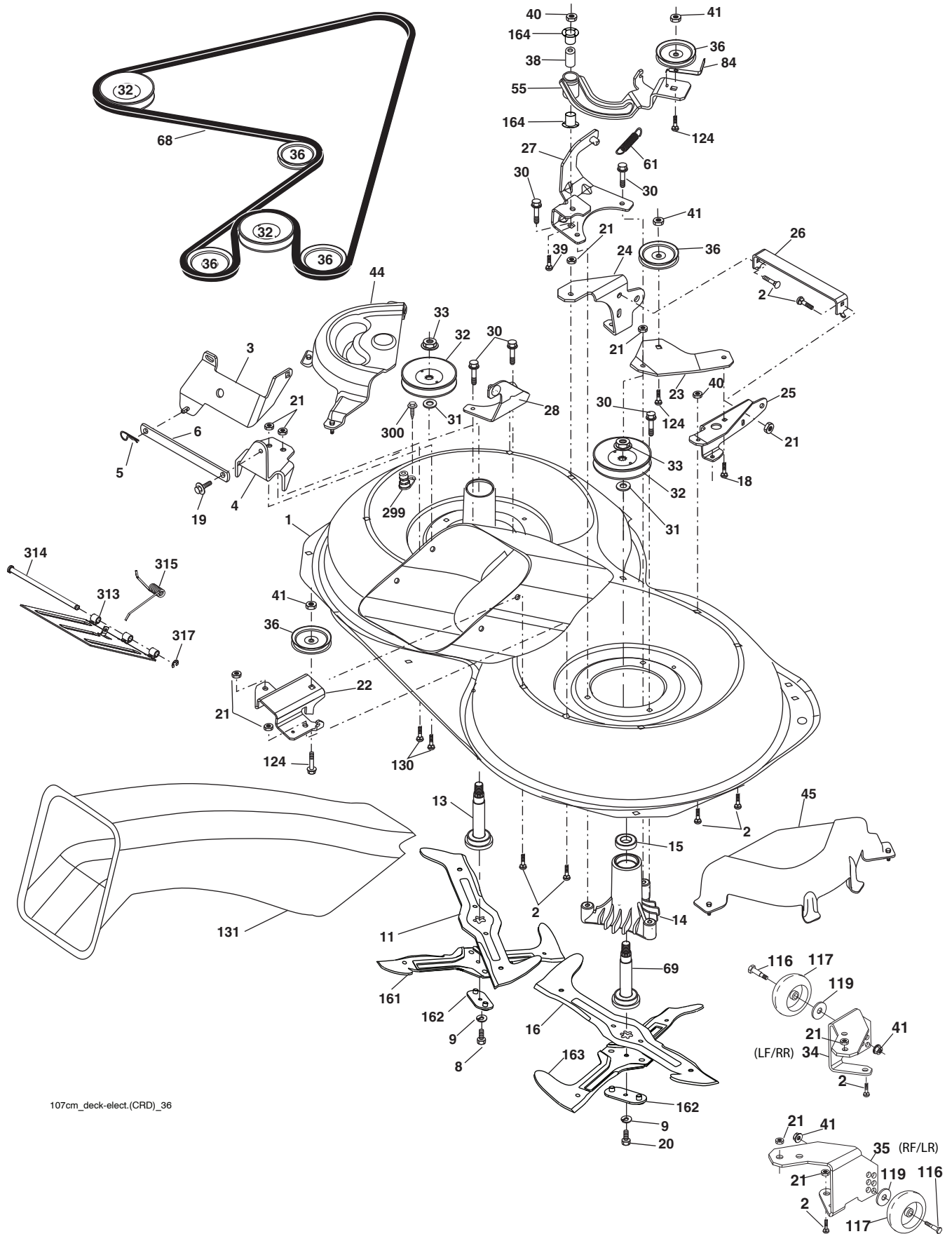

107cm_deck-elect.(CRD)_36

**TRACTOR - - MODEL NO. CTH192 96061030900, PRODUCT NO. 960 61 03-09
MOWER DECK 44**

KEY NO.	PART NO.	DESCRIPTION	KEY NO.	PART NO.	DESCRIPTION
1	532 44 10-61	Housing Asm. Mower	44	532 43 27-73	Cover Mandrel LH
2	872 14 05-06	Bolt Rdhd Sqnk 5/16-18 unc x 3/4	45	532 43 27-72	Cover Mandrel RH
3	532 43 18-64	Bracket Asm. S-Bar Chass	55	532 16 98-49	Arm Idler
4	532 16 91-67	Bracket Bar Sway Deck	61	532 19 94-87	Spring Tension Belt
5	532 12 46-70	Retainer Spring	68	532 40 20-09	Hex-Belt Mower
6	532 16 55-57	Bar Sway	69	532 16 54-82	Shaft Asm w/Lwr Brg RH Thd CRD
8	532 18 17-12	Bolt 3/8-24 x 1.25 Gr. 8 Patched	84	532 15 60-85	Keeper Belt Idler
9	810 03 06-00	Washer Lock Hvy 3/8 Unplated	116	532 19 34-06	Bolt Shoulder
11	532 18 05-83	Blade 3-1 LH	117	532 17 48-73	Wheel Gauge
13	532 13 76-45	Shaft Asm. w/Lower Bearing	119	819 13 20-12	Washer 3/8 x 7/8 x 14 Ga.
14	532 12 87-74	Housing Mandrel Vented (Machd)	124	872 11 06-12	Bolt Carr Sh 3/8-16 x 1-1/2 Gr. 5
15	532 11 04-85	Bearing Ball Mandrel	130	872 11 05-06	Bolt Rdhdsqnk 5/16-18 unc x 3/4
16	532 18 05-84	Blade 3-1 RH	131	532 43 81-63	Chute Bagger CRD
18	872 11 06-06	Bolt Rdhd Sqnk 3/8-16 x 3/4 Gr. 5	161	532 18 04-24	Blade Cross LH 107
19	532 13 28-27	Bolt Shoulder 5/16-18 Thd Form	162	532 18 08-78	Adapter Weldment Blade 107
20	532 18 17-13	Bolt 3/8-24 x 1.25 Gr. 8 Ptch LHthd	163	532 18 04-25	Blade Cross RH 107
21	873 68 05-00	Nut Crown Lock 5/16-18	164	532 12 49-37	Bearing
22	532 16 91-65	Bracket Idler Sprt RR	299	532 41 55-98	Port Washout
23	532 16 91-66	Bracket Idler Sprt RF	300	532 15 29-27	Screw TT #10-32.5.38 Flange
24	532 41 34-36	Bracket Suspension LH	313	532 43 81-97	Door EZ Mulch
25	532 40 01-05	Bracket Suspension RF	314	532 43 58-61	Pin Hinge
26	532 40 01-10	Brace Susp Frt CRD	315	532 43 99-28	Spring
27	532 16 91-72	Bracket Asm. Susp RR	317	532 43 79-88	E-Ring 5/16"
28	532 16 91-68	Bracket Asm. Susp LR	--	532 18 18-57	Mandrel Assembly (Includes housing (key #14), shaft assembly (key #69), and bearing (key #15) only - pulley/nut/washer and blade bolt/washers not included)
30	532 17 39-84	Screw Thd Rolling Dod. PT Hex	--	532 18 18-58	Mandrel Asm CRD LH Threads VC
31	532 18 76-90	Washer Spacer Mower Vented	--	532 43 92-57	Replacement Mower Complete
32	532 19 81-45	Mandrel Pulleys			
33	532 40 02-34	Nut Flg Top Lock			
34	532 40 01-03	Bracket Gauge Wheel LF			
35	532 40 01-04	Bracket Gauge Wheel RF			
36	532 14 67-63	Pulley Idler V-Groove Dim 4.25			
38	532 16 98-51	Spacer Hub Arm Idler			
39	872 11 06-22	Bolt RhHd 3/8-16 unc x 2-3/4 Gr. 5			
40	873 68 06-00	Nut Crownlock 3/8-16 unc			
41	873 90 06-00	Nut Flangelock 3/8-16 unc			

NOTE: All component dimensions given in U.S. inches
1 inch = 25.4 mm

TRACTOR - - MODEL NO. CTH192 96061030900, PRODUCT NO. 960 61 03-09
MOWER LIFT **45**

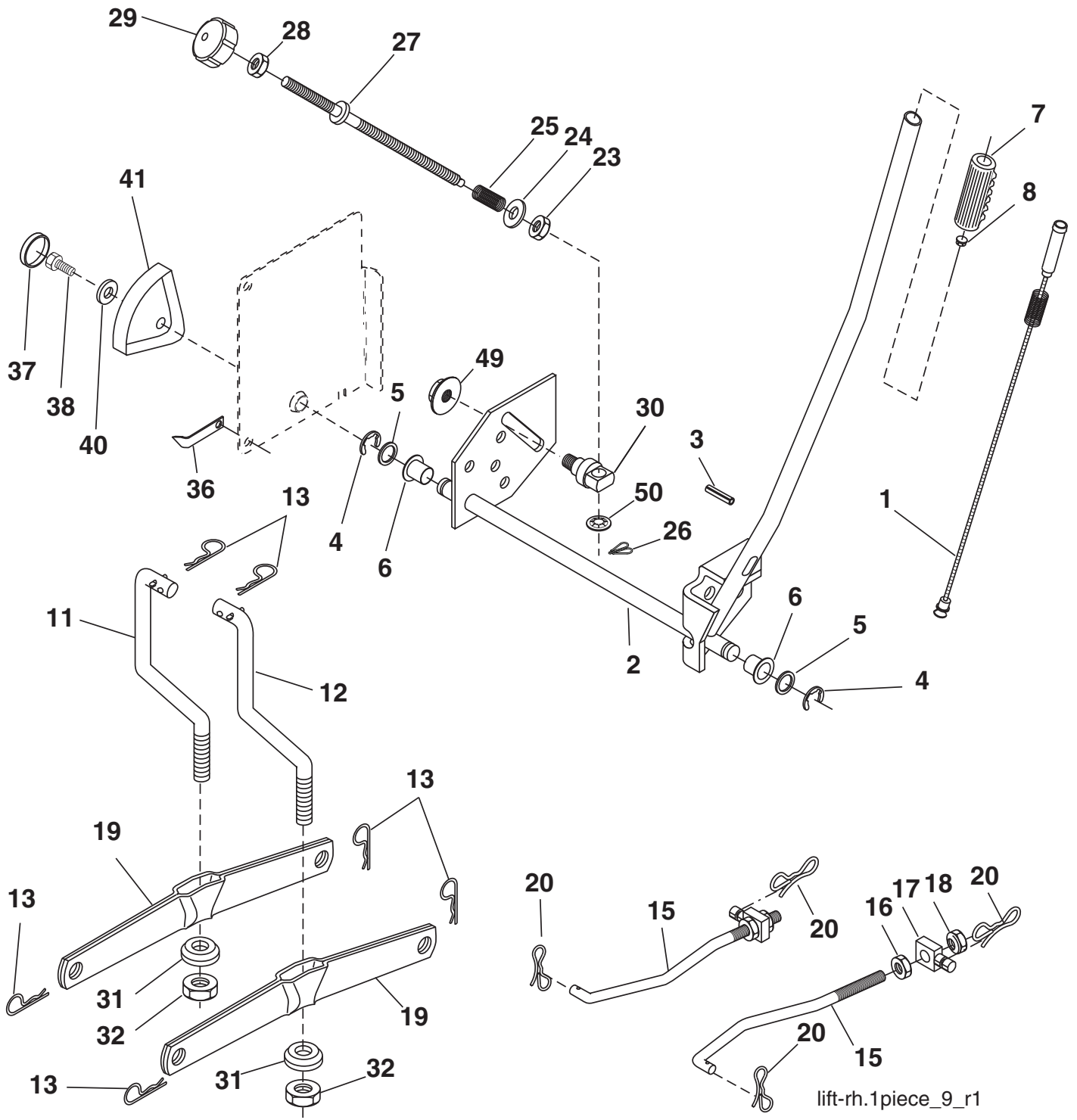

lift-rh.1piece_9_r1

**TRACTOR - - MODEL NO. CTH192 96061030900, PRODUCT NO. 960 61 03-09
MOWER LIFT 45**

KEY NO.	PART NO.	DESCRIPTION
1	532 40 49-81	Wire Asm Inner Spring w/Plunger
2	532 15 94-71	Shaft Asm. Lift
3	532 10 57-67	Pin Groove
4	812 00 00-02	E Ring #5133-62
5	819 21 16-21	Washer 21/32 x 1 x 21 Ga.
6	532 12 01-83	Bearing Nylon
7	532 12 56-31	Grip Handle
8	532 12 23-65	Button Plunger Black
11	532 16 58-29	Link Asm Lift LH
12	532 16 58-31	Link Asm Lift RH
13	532 12 46-70	Retainer Spring
15	532 17 32-88	Link Front
16	873 35 08-00	Nut Jam Hex 1/2-13 unc
17	532 17 56-89	Trunnion Blk Zinc
18	873 80 08-00	Nut Lock w/Wsh 1/2-13 unc
19	532 13 98-68	Arm Suspension Mower
20	532 19 42-09	Pin Cotter 7/16 Bowtie Lock
23	532 11 08-07	Nut Special
24	819 13 10-16	Washer 13/32 x 5/8 x 16 Ga.
25	532 16 40-24	Spring Compression INF. HGT.
26	532 16 94-84	Retainer Clip
27	532 16 45-43	Rod Adj Lift
28	873 35 06-00	Nut Hex Jam 3/8-16 unc
29	532 13 80-57	Knob Inf 3/8-16 unc Blk w/Sym
30	532 15 02-33	Trunnion Infin Height
31	532 16 98-65	Bearing, Pvt. Lift.
32	873 54 06-00	Nut Crownlock 3/8-24
36	532 15 50-97	Pointer Height Indicator
37	532 12 39-35	Plug Hole Blk 1.485/1.515 Dia
38	817 06 05-16	Screw 5/16-18 x 1
40	819 11 24-10	Washer 11/32 x 1-1/2 x 10 Ga.
41	532 12 39-34	Scale Ind Height Blk
49	532 40 91-49	Nut Hex Flange Lock
50	532 11 04-52	Nut Push Phos & Oil

NOTE: All component dimensions given in U.S. inches
1 inch = 25.4 mm

**TRACTOR - - MODEL NO. CTH192 96061030900, PRODUCT NO. 960 61 03-09
SEAT ASSEMBLY 42**

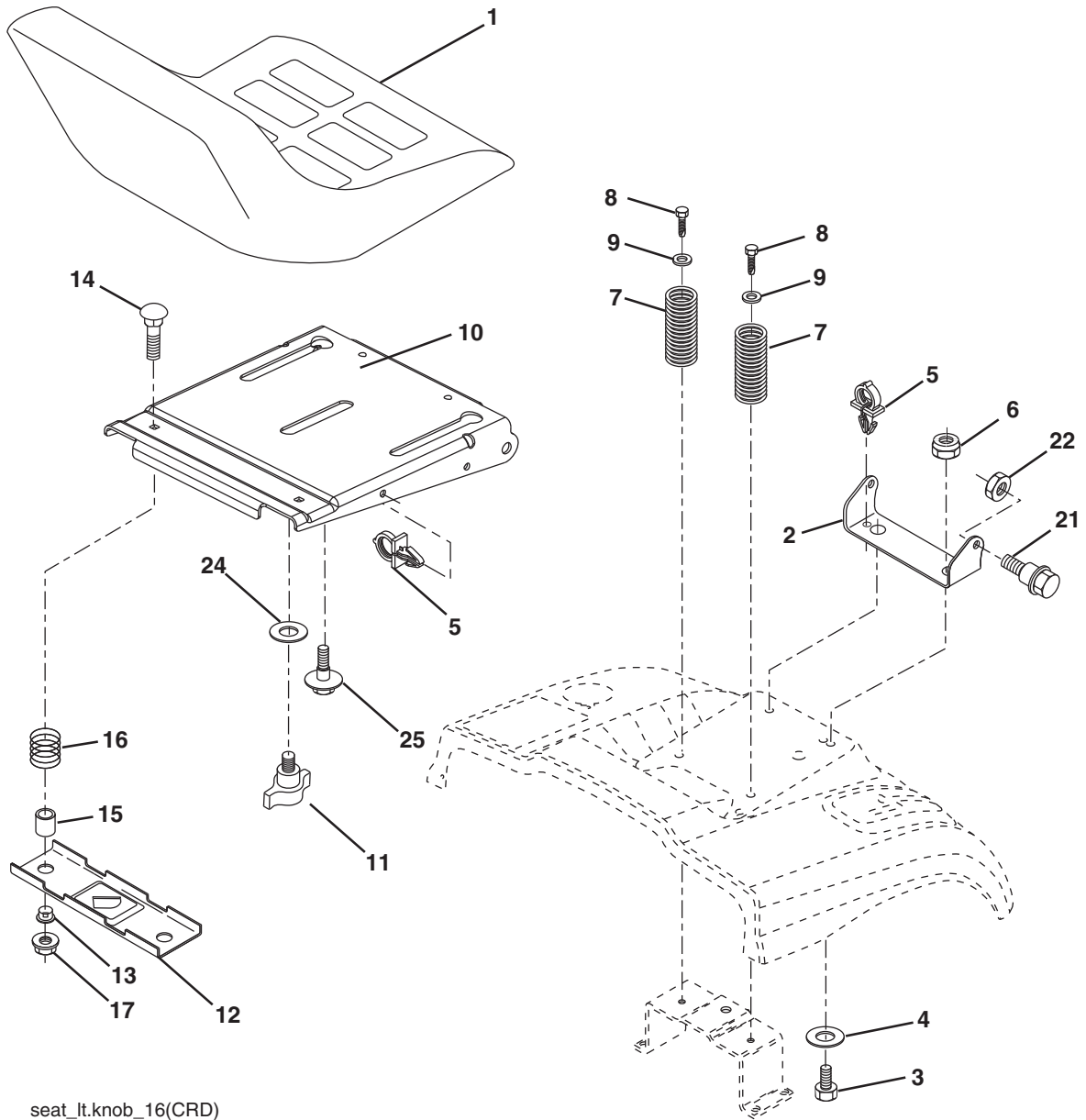

seat_lt.knob_16(CRD)

KEY NO.	PART NO.	DESCRIPTION	KEY NO.	PART NO.	DESCRIPTION
1	532 18 87-15	Seat	13	532 12 12-48	Bushing Snap Blk Nyl 50 Id
2	532 14 05-51	Bracket Pnt Pivot Seat (Blk)	14	872 05 04-12	Bolt Rdhd Sht Nk 1/4-20 x 1-1/2
3	871 11 06-16	Bolt Fin Hex 3/8-16 x 1	15	532 12 12-49	Spacer Split
4	819 13 16-10	Washer Flat 13/32 x 1 x 10 Ga.	16	532 12 37-40	Spring Cprsn
5	532 14 50-06	Clip Push In Hinged	17	532 12 39-76	Nut Lock 1/4 Lge Flg Gr. 5 Zinc
6	873 80 06-00	Nut Lock Hex w/Ins 3/8-16	21	532 17 18-52	Bolt Shoulder 5/16-18 unc-2A
7	532 12 41-81	Spring Seat Cprsn 2 250 Blk Zi	22	873 80 05-00	Nut Hex Lock w/Ins 5/16-18
8	817 00 06-16	Screw 3/8-16 x 1.5	24	819 17 19-12	Washer 17/32 x 1-3/16 x 12 Ga.
9	819 13 16-14	Washer 13/32 x 1 x 14 Ga.	25	532 12 70-18	Bolt Shoulder 5/16-18 x 62
10	532 19 55-30	Pan Pnt Seat			
11	532 16 63-69	Knob Seat Adj. Wingnut			
12	532 17 46-48	Bracket Pnt Mounting Switch			

NOTE: All component dimensions given in U.S. inches.
1 inch = 25.4 mm

**TRACTOR - - MODEL NO. CTH192 96061030900, PRODUCT NO. 960 61 03-09
BAGGER [46]**

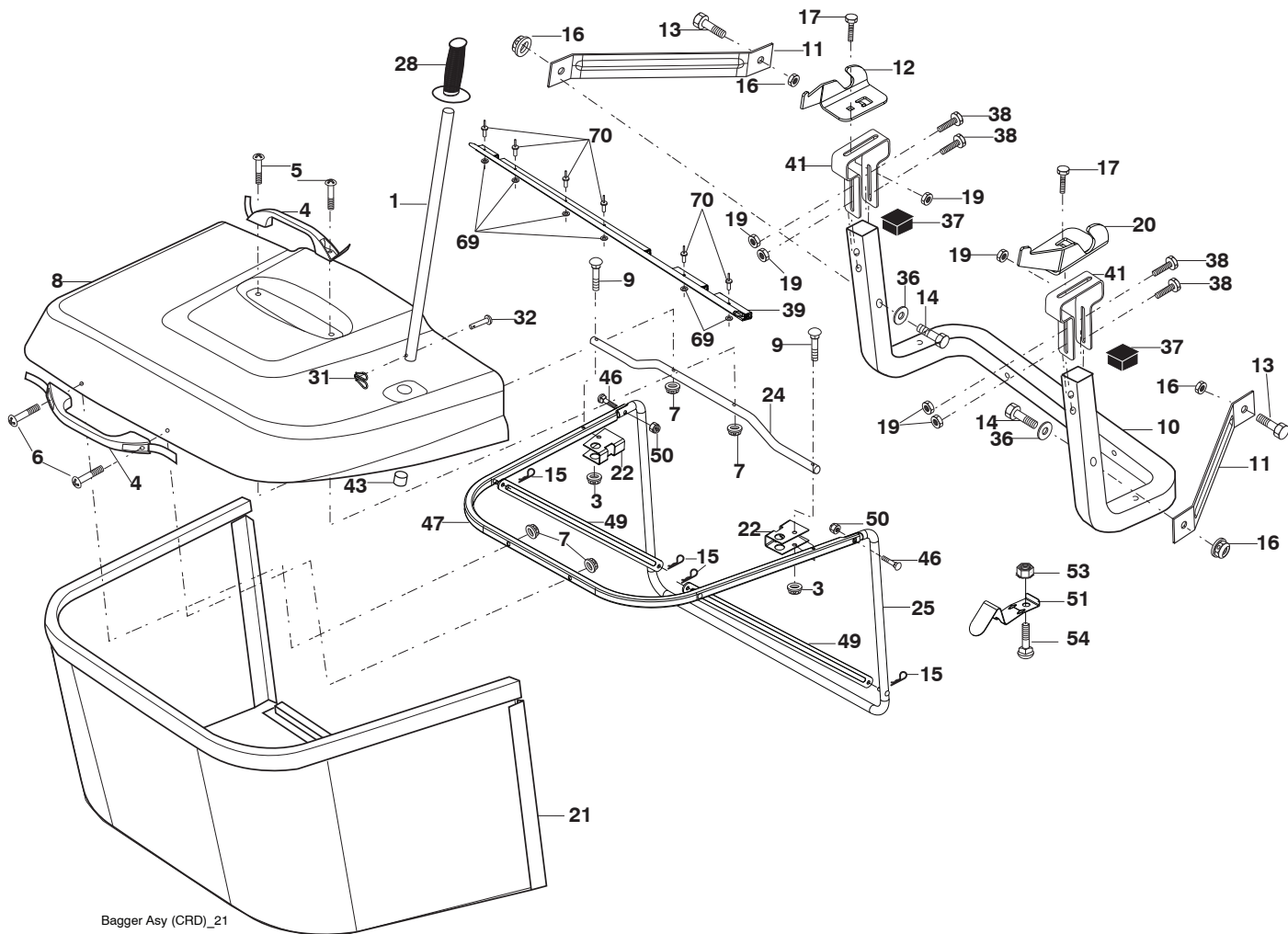

Bagger Asy (CRD)_21

KEY NO.	PART NO.	DESCRIPTION	KEY NO.	PART NO.	DESCRIPTION
1	532 42 86-10	Tube Handle Bagger CRD	28	532 16 57-87	Grip Handle
3	532 12 39-76	Nut Lock 1/4 Lge Flg Gr. 5 Zinc	31	532 16 94-84	Retainer Clip
4	532 16 99-16	Handle Bagger w/Lvrs Blk CRD	32	532 12 68-75	Rivet Rd Hd Drilled 3/8 Dia
5	874 98 10-24	Screw Pan Head #10-24 x 1.50 Blk	36	819 13 20-12	Washer 13/32 x 1-1/4 x 12 Ga.
6	874 98 10-32	Screw Pan Hd	37	532 17 54-01	Plug Support Bagger
7	873 40 10-00	Nut Wiz Lock Hex Serr/Hd 10-24	38	872 01 05-20	Bolt 5/16-18 x 2-1/2
8	532 44 15-87	Cover Bagger	39	532 41 62-57	Seal
9	872 14 04-18	Bolt Carriage 1/4-20 x 2.25d x Gr. 5	41	532 43 27-55	Bracket Pvt Bagger CRD
10	532 18 12-82	Tube Support Bagger CRD	43	532 17 40-83	Plug Tubing End
11	532 16 57-19	Bracket Support Upper Bag CRD	46	872 11 05-10	Bolt 5/16-18 x 1-1/4
12	532 18 88-48	Bracket Pivot LH	47	532 19 37-04	Tube Upper Bagger
13	874 76 06-12	Bolt Fin Hex 3/8-16 unc x 3/4	49	532 19 33-05	Bar Spreader
14	874 52 06-36	Bolt Fin Hex 3/8-16 x 2-1/4 Gr. 5	50	873 80 05-00	Nut 5/16-18
15	532 12 46-70	Retainer Spring	51	532 19 99-03	Latch Spring Bagger
16	873 90 06-00	Nut Lock 3/8-16 unc	53	873 51 04-00	Nut 1/4-20 unc
17	872 14 05-06	Bolt Rdhd Sqnk 5/16-18 unc x 3/4	54	872 14 04-06	Bolt 1/4-20 x 3/4 Gr. 5
19	873 90 05-00	Nut Lock Hex Flange 5/16-18	69	532 43 56-11	Washer .125
20	532 18 88-47	Bracket Pivot RH	70	532 43 56-03	Rivet Pop .125 x .750
21	532 40 61-80	Bag Asm CRD			
22	532 42 82-36	Bracket Side Bagger CRD			
24	532 16 57-83	Tube Pivot Bagger CRD			
25	532 19 37-05	Tube Front Bagger			

NOTE: All component dimensions given in U.S. inches
1 inch = 25.4 mm

