

532 44 56-42



Repair Parts Manual
Manual De Repuestos
GTH24V52LS / 96043013500

Please read the operator's manual carefully and make sure you understand the instructions before using the machine.

Por favor lea cuidadosamente y comprenda estas intrucciones antes de usar esta maquina.



English/Spanish

HOW TO USE THIS MANUAL

This manual is designed to provide the customer with a means to identify the parts on his/her tractor when ordering repair parts. The illustrations may or may not represent the actual assemblies; therefore, it is not recommended to use this manual as a guide to assemble or disassemble the tractor. Some hardware and parts are drawn larger in order to more readily identify them.

Each tractor has its own model number.

The model number for your tractor can be found on the fender under the seat.

When ordering parts, always give the following information:

- Product - "TRACTOR"
- MODEL NUMBER - "GTH24V52LS" (96043013500)"
- Part Number
- Part Description

TABLE OF CONTENTS

SCHEMATIC	3
ELECTRICAL.....	4-5
CHASSIS	6-7
DRIVE.....	8-9
ENGINE.....	10-11
STEERING	12-13
MOWER DECK.....	14-15
MOWER LIFT.....	16
SEAT	17
DECALS.....	18

COMO UTILIZAR ESTE MANUAL

Este manual está diseñado para brindarle al comprador un medio para identificar las piezas del tractor para cuando necesite hacer el pedido de un repuesto. Las ilustraciones pueden o no representar los ensambles reales; por lo tanto, no se recomienda utilizar este manual como una guía para ensamblar o desarmar el tractor. Algunos accesorios y piezas están dibujados en tamaños más grandes para identificarlos con mayor facilidad.

Cada tractor tiene su propio número de modelo.

El número de modelo del tractor se encuentra en el guardabarros debajo del asiento.

Cuando haga el pedido de una pieza, siempre brinde la siguiente información:

- Producto: "TRACTOR"
- NÚMERO DE MODELO: "GTH24V52LS" (96043013500)"
- Número de pieza
- Descripción de la pieza

ÍNDICE

DIAGRAMA.....	19
DIAGRAMA ELÉCTRICO	20-21
CHASIS.....	22-23
TRANSMISIÓN	24-25
MOTOR	26-27
DIRECCIÓN	28-29
PLATAFORMA DE LA CORTADORA DE CÉSPED.....	30-31
ELEVACIÓN DE LA CORTADORA DE CÉSPED.....	32
ASIENTO.....	33
CALCOMANÍAS.....	34

TRACTOR - MODEL NO. GTH24V52LS (96043013500), PRODUCT NO. 960 43 01-35 SCHEMATIC

SCH12

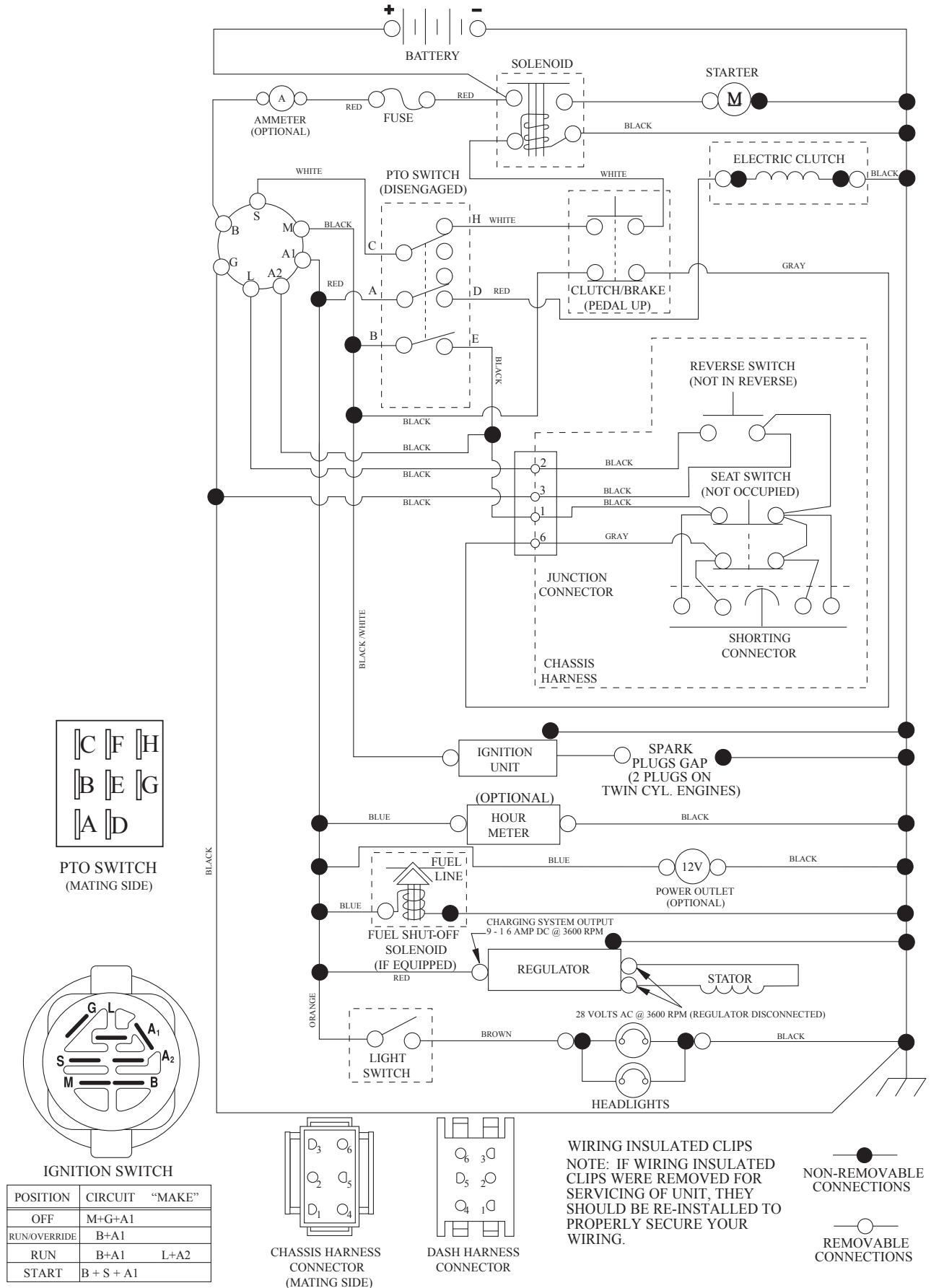

**TRACTOR - MODEL NO. GTH24V52LS (96043013500), PRODUCT NO. 960 43 01-35
ELECTRICAL**

T14S

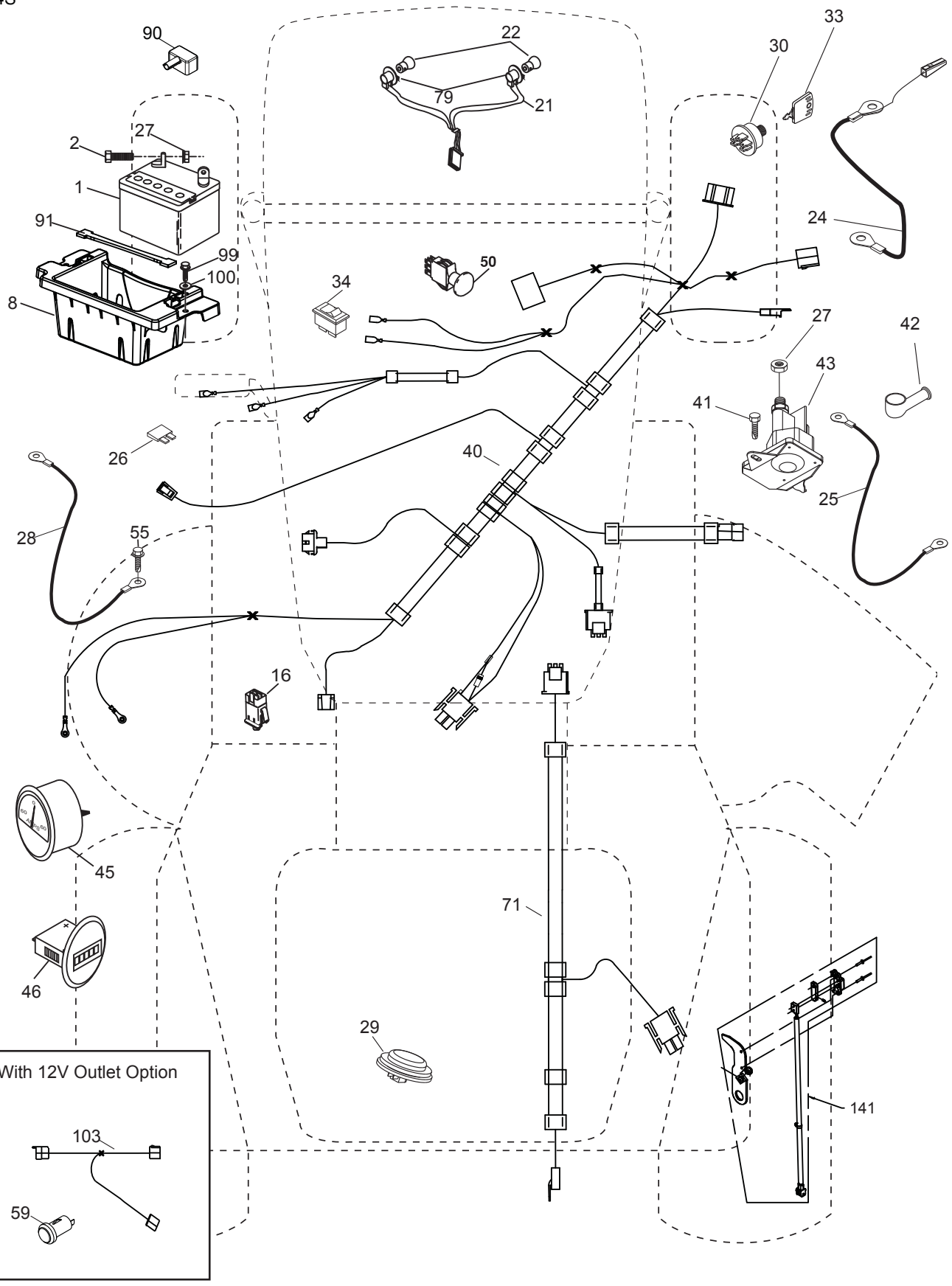

**TRACTOR - MODEL NO. GTH24V52LS (96043013500), PRODUCT NO. 960 43 01-35
ELECTRICAL**

KEY NO.	PART NO.	DESCRIPTION
1	532 16 34-65	Battery
2	874 76 04-12	Bolt Hex Hd 1/4-20 unc x 3/4
8	532 41 41-25	Battery Box
16	532 17 61-38	Switch Interlock
21	532 40 02-52	Harness Socket Light
22	532 00 41-52	Bulb, Light #1156
24	532 40 02-53	Cable Battery
25	532 41 28-95	Cable Starter
26	532 17 51-58	Fuse
27	873 51 04-00	Nut Keps Hex 1/4-20 unc
28	532 14 54-91	Cable Ground 21" Blk 6 Ga.
29	532 40 15-45	Switch Seat
30	532 19 33-50	Switch Ign
33	532 41 19-33	Key/Chain
34	532 11 07-12	Switch Light/Reset
40	532 40 21-67	Harness Ign. Dash
41	817 72 04-08	Screw 1/4-20 unc x 1/2
42	532 13 15-63	Cover Terminal Red
43	532 19 25-07	Solenoid
45	532 42 52-70	Ammeter Round
46	532 42 52-71	Gauge Hourmeter
50	532 17 46-51	Switch PTO
55	817 06 05-12	Screw Thdrol 5/16-18 x 3/4
59	532 40 03-03	Outlet 12-Volt
71	532 19 42-76	Harness Ign Chassis
79	532 17 52-42	Socket Asm. Bulb Twistlock
90	532 43 53-95	Cover Terminal Battery
91	532 19 02-70	Strap Battery
99	817 67 04-12	Screw Hexwsh Thdrol 1/4-20 x 3/4
100	819 09 14-16	Washer 9/32 x 7/8 x 16 Ga.
103	532 42 17-47	Harness Pigtail 12V Outlet
141	532 42 12-25	Kit G700/G730 ROS

NOTE: All component dimensions given in U.S. inches
1 inch = 25.4 mm

TRACTOR - MODEL NO. GTH24V52LS (96043013500), PRODUCT NO. 960 43 01-35
CHASSIS

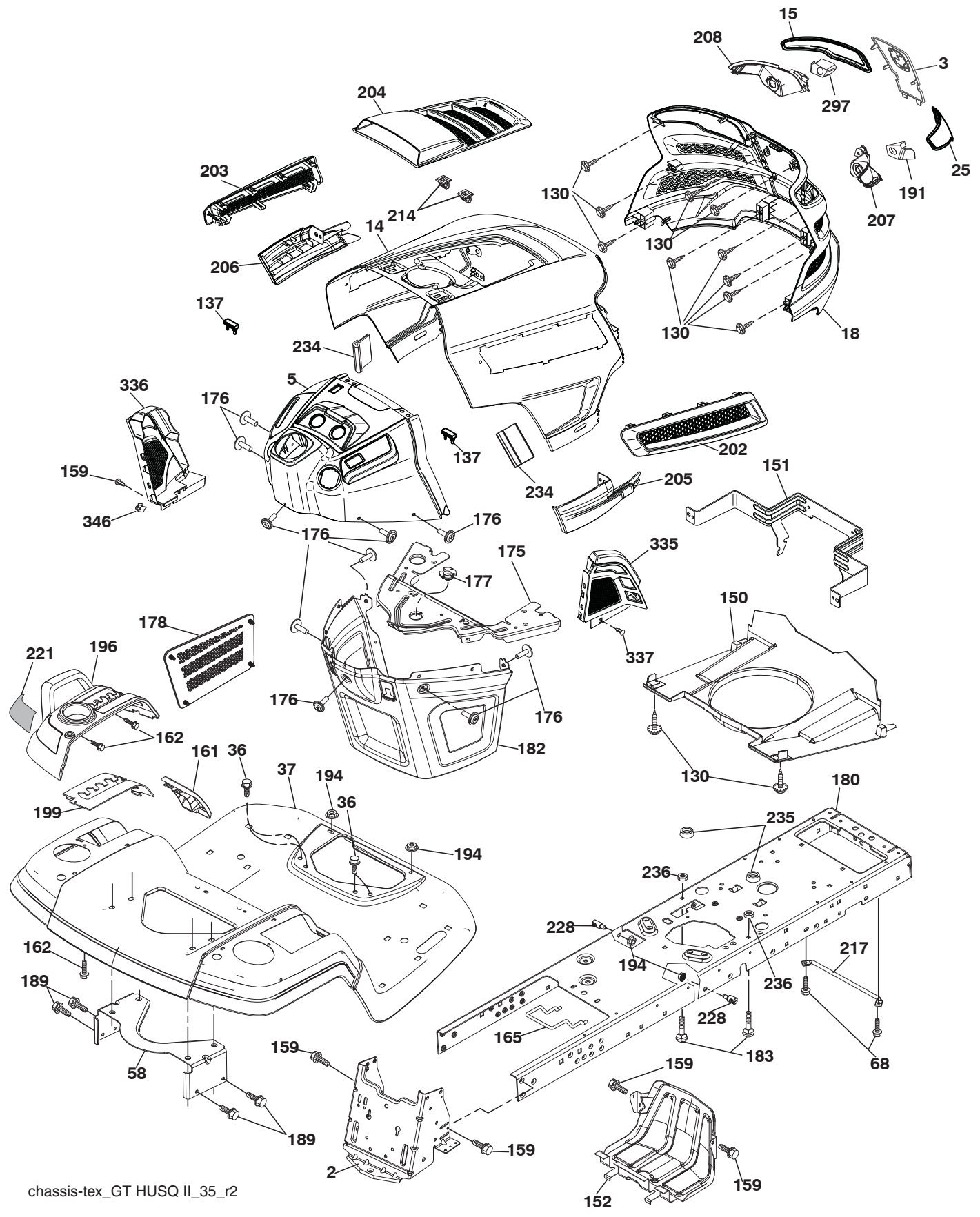

chassis-tex_GT HUSQ II_35_r2

**TRACTOR - MODEL NO. GTH24V52LS (96043013500), PRODUCT NO. 960 43 01-35
CHASSIS**

KEY NO.	PART NO.	DESCRIPTION
2	532 19 42-61	Drawbar
3	532 43 97-52	Applique
5	532 43 74-70	Dash
14	532 44 11-77	Hood
15	532 43 97-33	Lens LH
18	532 43 77-62	Grille Asm
25	532 44 33-85	Lens RH
36	817 06 05-12	Screw 5/16-18 x 3/4
37	532 44 12-08	Fender
58	532 19 43-14	Bracket Fender
68	817 49 05-08	Screw 5/16-18 x 1/2
130	532 41 63-58	Screw #10 x 0.750 BOS Thread
137	532 40 75-90	Bumper Dash
150	532 43 97-74	Duct Air
151	532 43 66-70	Bracket Pivot Hood
152	532 43 98-70	Shield Browning/Debris
159	817 00 06-12	Screw 3/8-16 x 3/4
161	532 43 99-29	Console Fuel Window
162	532 14 24-32	Screw Hex Wsh Hi-Lo 1/4 x 1/2
165	532 19 43-30	Bracket Support Tank
175	532 19 63-04	Crossmember
176	532 40 07-76	Screw 10-24 x 5/8 Wshd Qdrx
177	532 19 52-27	Bushing Steering
178	532 19 97-82	Cargo Asm. Net
180	532 19 42-60	Chassis
182	532 40 68-59	Dash Lower
183	874 52 05-20	Bolt 5/16-18 x 1-1/4
189	817 00 05-12	Screw 5/16-18 x 3/4
191	532 43 74-55	Insert Reflective RH
194	873 90 05-00	Nut Lock Hex Flange 5/16-18
196	532 43 96-74	Console Asm. Deck Lift

KEY NO.	PART NO.	DESCRIPTION
199	532 19 82-59	Plate Deck Lift
202	532 43 97-28	Vent Side Hood RH
203	532 43 97-27	Vent Side Hood LH
204	532 43 57-14	Vent Asm Hood Top
205	532 43 97-30	Skirt Hood Side RH
206	532 43 97-29	Skirt Hood Side LH
207	532 43 97-34	Bezel RH
208	532 43 97-35	Bezel LH
214	532 19 91-45	Clip Retainer
217	532 40 91-67	Rod Pivot
221	532 19 89-09	Reflector LH
228	532 19 51-61	Stud Fastener
234	532 40 47-42	Bumper Hood
235	532 40 61-29	Spacer Fender
236	873 93 05-00	Nut Center Lock 5/16-18 unc
297	532 43 74-56	Insert Reflective LH
335	532 43 98-47	Cover RH
336	532 44 53-09	Cover LH
337	532 43 81-37	Clip
346	532 12 64-71	Clip Insulator
- -	532 42 49-18	Kit Guard Brush

NOTE: All component dimensions given in U.S. inches
1 inch = 25.4 mm

**TRACTOR - MODEL NO. GTH24V52LS (96043013500), PRODUCT NO. 960 43 01-35
DRIVE**

KEY NO.	PART NO.	DESCRIPTION	KEY NO.	PART NO.	DESCRIPTION
1	---	Transaxle, Hydro G7-BCBB-1XDC-1FCA (420331) (Order parts from transaxle manufacturer.)	153	532 12 47-88	Retainer Spring
2	532 00 70-70	Key 1/4 x 2.5	159	876 02 04-12	Pin Cotter 1/8 x 3/4
3	532 00 75-63	Washer Thrust Axle Hardened	160	532 16 94-84	Retainer Clip
7	532 19 98-37	Hub Asm. Wheel	161	532 10 57-09	Spring, Return, Clutch
9	532 14 00-80	Bolt Hub Wheel	163	532 41 81-85	Rod Pedal Control
15	819 13 13-16	Washer 13/32 x 13/16 x 16 Ga.	166	532 42 91-64	Nut Push .625
17	532 19 72-96	Spring, Brake	167	532 40 52-57	Latch Brake Parking
26	532 19 96-79	Spring Return Cruise	184	532 44 14-55	Handle Parking Brake
29	532 41 81-86	Rod, Brake	186	532 19 43-21	Spacer Retainer
33	812 00 00-53	Ring E	187	819 13 32-10	Washer
35	532 43 54-86	Rod, Brake, Park	188	532 19 43-23	Link Clutch Ground Drive
42	532 12 48-72	Cover, Foot Pedal	189	532 40 75-04	Bellcrank Ground Drive
48	872 11 06-12	Bolt Carr Sh 3/8-16 x 1-1/2 Gr.5	190	532 40 75-05	Keeper Bellcrank Ground Drive
49	872 11 06-14	Bolt	196	817 00 06-16	Screw 3/8-16 x 1
50	532 19 43-27	Pulley Idler Flat	197	532 19 97-69	Bracket Clutch Anti-Rotation
51	873 90 06-00	Lock Nut 3/8-16	203	819 11 11-16	Washer 11/32 x 11/16 x 16 Ga.
52	532 19 43-26	Idler V-Groove Offset	206	532 19 78-67	Bracket Mount Latch Cruise
56	532 42 08-07	V-Belt, Drive	207	532 19 78-68	Latch Control Cruise
64	532 19 78-65	Shaft Asm. Pedal Brake Control	208	532 19 78-69	Gear Sector Control Cruise
69	532 12 38-00	Washer 1-1/32 x 1-5/8 x 16 Ga.	209	532 19 95-92	Rod Control Cruise
70	532 43 96-61	Console Asm	210	532 19 78-60	Rocker Asm. Pedal Control
73	874 49 05-48	Bolt Hex 5/16-18 x 3 Gr. 5	211	532 12 01-83	Bearing Nylon
74	532 14 24-32	Screw 1/4 x 1/2	213	532 40 31-19	Knob Control Cruise
80	532 41 81-84	Strap Torque	214	532 41 68-63	Pedal Forward
92	874 76 05-20	Bolt 5/16-18 x 1/2	215	532 40 17-23	Pedal Reverse
99	532 41 81-88	Spring Bypass	220	532 19 89-08	Reflector RH
114	873 80 05-00	Nut Lock Hex W/Ins. 5/16-18 unc	221	532 40 31-87	Retainer Spring Clip Handle
116	873 90 05-00	Nut Lock Hex Flange 5/16-18	222	879 21 20-10	Washer 21/32 x 1-1/4 x 10 Ga.
121	532 17 56-11	Bracket Strap Torque	284	532 41 76-93	Nut U-Chnl. 1/4-20
125	817 00 05-12	Screw 5/16-18 x 3/4	286	872 01 05-20	Bolt 5/16-18 x 2.50
145	532 16 31-68	Washer Axle Flange	307	874 18 04-12	Screw Mach 1/4-20 x 3/4

NOTE: All component dimensions given in U.S. inches
1 inch = 25.4 mm

**TRACTOR - MODEL NO. GTH24V52LS (96043013500), PRODUCT NO. 960 43 01-35
ENGINE**

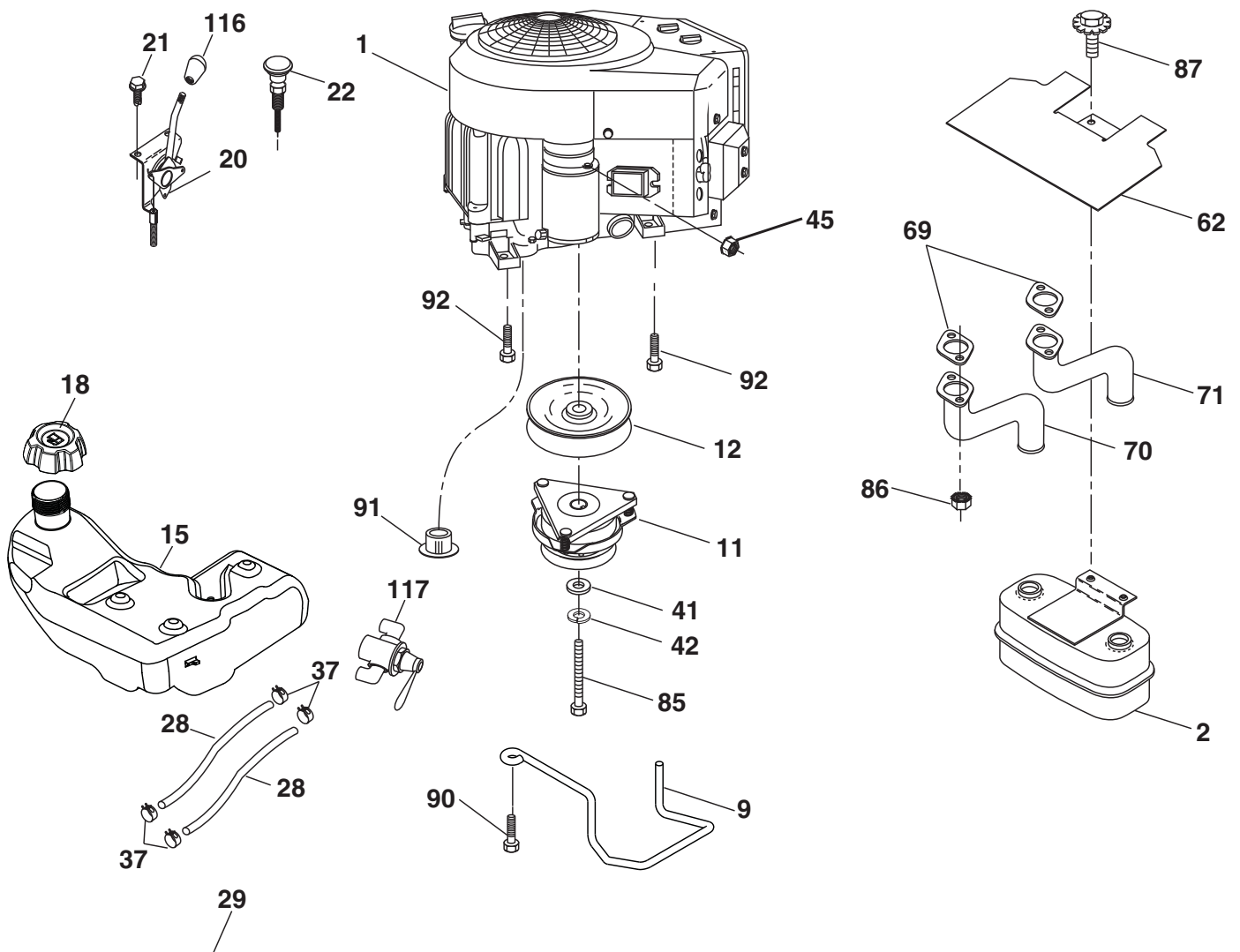

SPARK ARRESTER KIT

engine-tex_Kawa-2cyl_9

**TRACTOR - MODEL NO. GTH24V52LS (96043013500), PRODUCT NO. 960 43 01-35
ENGINE**

KEY NO.	PART NO.	DESCRIPTION
1	-- -- -- --	Engine KAWA Model No. FR730V-DS04 (445363)(Order parts from engine manufacturer.)
2	532 14 97-23	Muffler
9	532 40 86-67	Keeper Asm. Belt Engine
11	532 17 93-35	Clutch Electric
12	532 19 43-43	Pulley Engine
15	532 42 29-48	Tank Fuel
18	532 43 92-08	Cap Asm
20	532 42 43-41	Control Throttle
21	532 41 63-58	Screw #10 x 0.750 BOS Thread
22	532 19 15-96	Control Choke
28	532 40 11-35	Fuel Line
29	532 13 71-80	Spark Arrester Kit
37	532 12 34-87	Clamp Hose
41	532 12 61-97	Washer 1-1/2 OD x 15/32 ID x .250
42	810 04 07-00	Washer Lock 7/16
45	873 51 04-00	Nut Keps Hex 1/4-20 unc
62	532 43 40-17	Shield Heat Muffler
69	532 17 81-51	Gasket
70	532 42 47-65	Tube Exhaust LH
71	532 42 47-66	Tube Exhaust RH
85	532 17 99-53	Bolt 7/16-20 x 3.75 Gr. 5
86	532 18 43-62	Nut Hex M8-1.25
87	532 19 82-39	Bolt 5/16-18 unc x 1 w/Sems
90	817 00 06-16	Screw 3/8-16 x 1
91	532 18 74-95	Bushing
92	817 12 06-16	Screw 3/8-16 x 1
116	539 13 26-24	Knob Soft Touch
117	532 42 08-28	Valve Fuel Reserve

NOTE: All component dimensions given in U.S. inches
1 inch = 25.4 mm

For engine service and replacement parts, call the toll free number for your engine manufacturer listed below:

Kawasaki 1-949-460-5688

**TRACTOR - MODEL NO. GTH24V52LS (96043013500), PRODUCT NO. 960 43 01-35
STEERING ASSEMBLY**

KEY NO.	PART NO.	DESCRIPTION
1	532 43 97-40	Wheel, Steering
2	532 19 59-68	Axle Asm., Front
4	532 40 30-89	Spindle Asm. LH
5	532 40 30-90	Spindle Asm. RH
6	532 12 49-31	Bearing, Race Thrust Harden
7	532 12 17-48	Washer 25/32 x 1-5/8 x 16 Ga.
8	812 00 00-29	Ring, Clip #T5304-75
9	532 12 12-32	Cap, Spindle
13	532 12 17-49	Washer 25/32 x 1-1/4 x 16 Ga.
14	810 04 06-00	Washer, Lock Hvy Hlcl Spr 3/8
15	873 54 06-00	Nut, Crown Lock 3/8-24 unf
16	532 40 82-19	Shaft Steering
19	532 19 47-29	Plate Steering
21	532 18 67-37	Adapter, Wheel Steering
22	532 42 05-37	Steering Support Lower
26	532 43 97-43	Insert, Wheel Steering
28	817 00 06-12	Screw 3/8-16 x 3/4
35	532 19 47-32	Gear, Sector Plate
45	819 18 38-12	Washer 9/16 x 2-3/8 x 12 Ga.
50	873 90 06-00	Nut Lock Flange 3/8-16 unc
51	873 94 08-00	Nut Hex Jam Toplock 1/2-20 unf
53	532 18 89-67	Washer Hardened .793x1.637x.060
54	874 76 06-36	Bolt Hex 3/8-16 unc x 2-1/4
55	532 41 47-36	Bolt Hex 3/8-16 unc x 2-1/4
58	532 19 47-47	Bolt Shoulder Sector Pivot CFM
59	532 19 47-48	Washer Thrust Sector Steering
60	873 97 10-00	Nut Flange Lock 5/8-11
61	532 19 47-40	Draglink, LH
62	532 19 47-41	Draglink, RH
63	817 00 05-12	Screw 5/16-18 x 3/4
64	532 19 98-49	Retainer Clip Spring Steering
65	532 19 47-34	Brace Axle Front
66	871 02 07-48	Bolt Hex Fghd 7/16-14 x 3 Serr
67	532 19 47-37	Bushing PM Front Axle
68	873 90 07-00	Nut Lock Flange 7/16-14 Gr. 5
69	532 19 91-62	Washer 1.5 x .505 x .118
70	532 19 61-97	Bracket Deck Susp. Front
78	532 05 70-79	Washer Thrust

NOTE: All component dimensions given in U.S. inches
1 inch = 25.4 mm

TRACTOR - MODEL NO. GTH24V52LS (96043013500), PRODUCT NO. 960 43 01-35
MOWER DECK

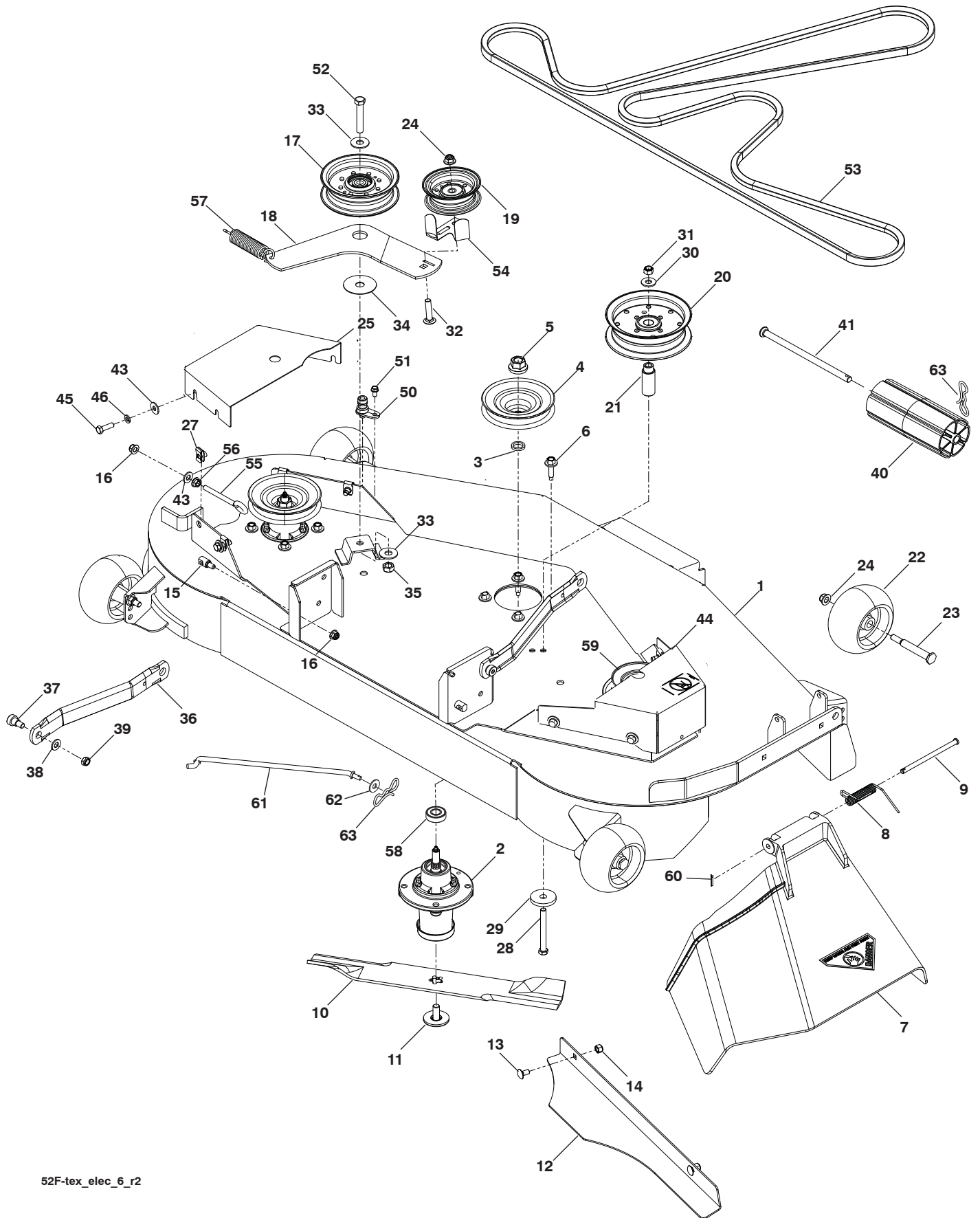

52F-tex_elec_6_r2

**TRACTOR - MODEL NO. GTH24V52LS (96043013500), PRODUCT NO. 960 43 01-35
MOWER DECK**

KEY NO.	PART NO.	DESCRIPTION	KEY NO.	PART NO.	DESCRIPTION
1	532 44 53-60	Deck	36	532 19 51-85	Arm, Susp., Rear
2	539 11 21-70	Housing Assembly	37	539 11 36-21	Sb 3/8-16 x 3/8 Skt Hd
3	539 18 76-90	Washer-Spacer	38	539 99 01-22	Washer, 3/8 Sae Flt
4	532 10 75-21	Pulley, Mandrel	39	539 20 02-82	Nut, 3/8-16 Hex Jam Nyloc
5	539 40 02-34	Nut, 9/16 Top Center Lock	40	532 17 60-66	Roller Nose
6	539 10 76-30	Screw, Washer Head	41	532 17 91-27	Rod Roller Nose
7	539 11 07-33	Discharge Chute	43	539 99 06-92	Washer, 5/16 Std Flt
8	539 11 07-35	Spring - Torsion	44	575 32 00-02	Shield, Belt RH
9	539 11 07-36	Pin, Clevis 5/16 x 5.19	45	539 99 02-09	Hcs 5/16-18 x 1 Gr 5
10	574 87 08-01	Blade, 16-1/4"	46	539 99 01-87	Wash 5/16 Slw
11	539 10 75-22	Bolt, 7/16, Assy Blade	50	532 41 55-98	Washout Port
12	574 87 50-02	Confinement Plate	51	539 10 84-61	Bolt, 1/4-20 x 1/2
13	539 99 07-99	Rhsnb 5/16-18 x 5/8 Gr 5	52	539 10 48-70	Hcs 7/16-14 x 2-1/2 Gr 5
14	539 99 07-17	Nut 5/16-18 Hex Nyloc	53	574 84 56-03	Belt, Deck
15	532 19 51-61	Stud, Fasten w/ Anti- Rotate	54	575 22 43-01	Guard, Belt
16	539 11 28-99	Nut 5/16-18 Hex Flange Nyloc	55	539 11 55-74	Eyebolt 5/16 x 3-1/2
17	532 19 61-04	Pulley, Idler Spec. Hub	56	539 99 05-85	Nut 5/16-18 Hex Whizlk
18	574 84 18-02	Arm, Idler, Blk	57	539 10 68-50	Spring
19	532 17 79-68	Pulley, Idler	58	539 11 20-50	Ball Bearing
20	539 13 27-28	Pulley, Idler	59	575 35 29-01	Pulley
21	575 22 45-01	Idler Bushing	60	532 16 94-84	Clip Retainer
22	539 10 76-10	Wheel, Gauge	61	532 40 48-51	Rod Anti-Sway
23	532 19 34-06	Bolt, Shoulder	62	819 13 13-12	Washer 13/32 x 13/16 x 12 Ga.
24	521 99 65-01	Nut 3/8-16 Hex Flg Nyloc	63	532 19 42-08	Pin Cotter 5/16 Bow Tie Lock
25	575 22 47-02	Shield, Belt LH	--	532 44 53-61	Mower Deck Complete
27	539 10 47-63	Retainer 5/16c U Type			
28	539 10 82-71	Hcs 3/8-16 x 3-1/2 Gr 5			
29	539 10 65-04	Heavy Washer			
30	539 99 05-17	Washer, 3/8 Flat Std			
31	539 97 69-79	Nut 3/8-16 Hex Nyloc			
32	539 99 09-23	Rhsnb 3/8-16 x 1-3/4 Gr 5			
33	539 10 48-64	Washer, 7/16 Flat			
34	532 17 85-15	Washer, Flat Hardened			
35	539 11 91-24	Nut, 7/16-14 Hex Nyloc			

NOTE: All component dimensions given in U.S. inches
1 inch = 25.4 mm

**TRACTOR - MODEL NO. GTH24V52LS (96043013500), PRODUCT NO. 960 43 01-35
MOWER LIFT**

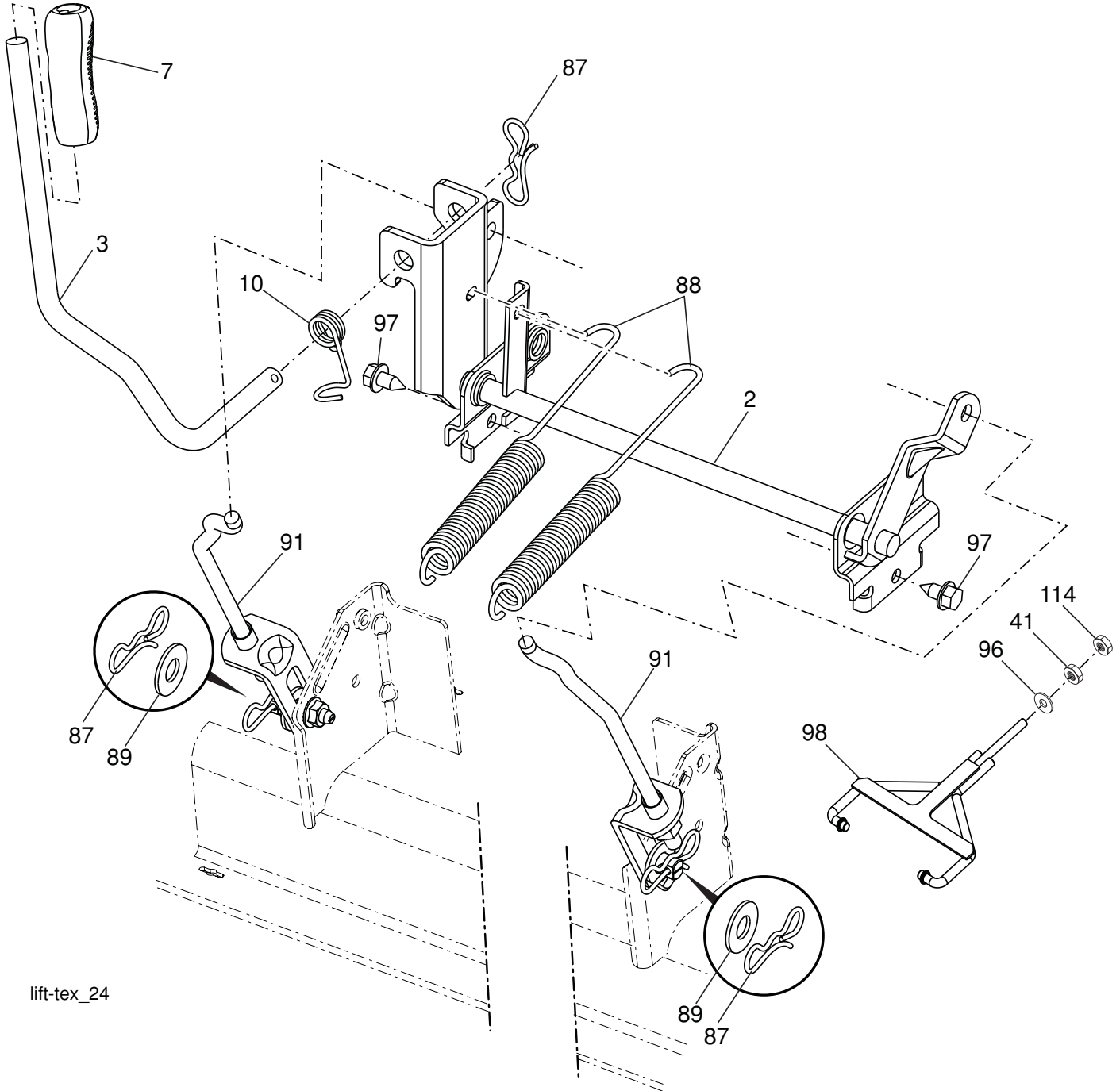

lift-tex_24

KEY NO.	PART NO.	DESCRIPTION
2	532 42 20-27	Shaft Asm., Lift
3	532 19 52-30	Lever Asm., Lift RH
7	532 41 17-42	Grip, Lever
10	532 19 63-14	Spring Torsion
41	532 17 59-94	Nut Lift Link
87	532 19 42-09	Pin Cotter 7/16 Bow Tie Lock
88	532 19 53-04	Spring Lift Assist
89	819 19 19-12	Washer Clear Zinc

KEY NO.	PART NO.	DESCRIPTION
91	532 40 34-07	Link Lift Susp Mower Rear
96	532 19 52-63	Bushing Spherical
97	817 00 06-12	Screw 3/8-16 x .75
98	574 82 25-01	Link Lift Susp. Front Mower
114	873 36 07-00	Nut Jam 7/16-20

NOTE: All component dimensions given in U.S. inches
1 inch = 25.4 mm

**TRACTOR - MODEL NO. GTH24V52LS (96043013500), PRODUCT NO. 960 43 01-35
SEAT ASSEMBLY**

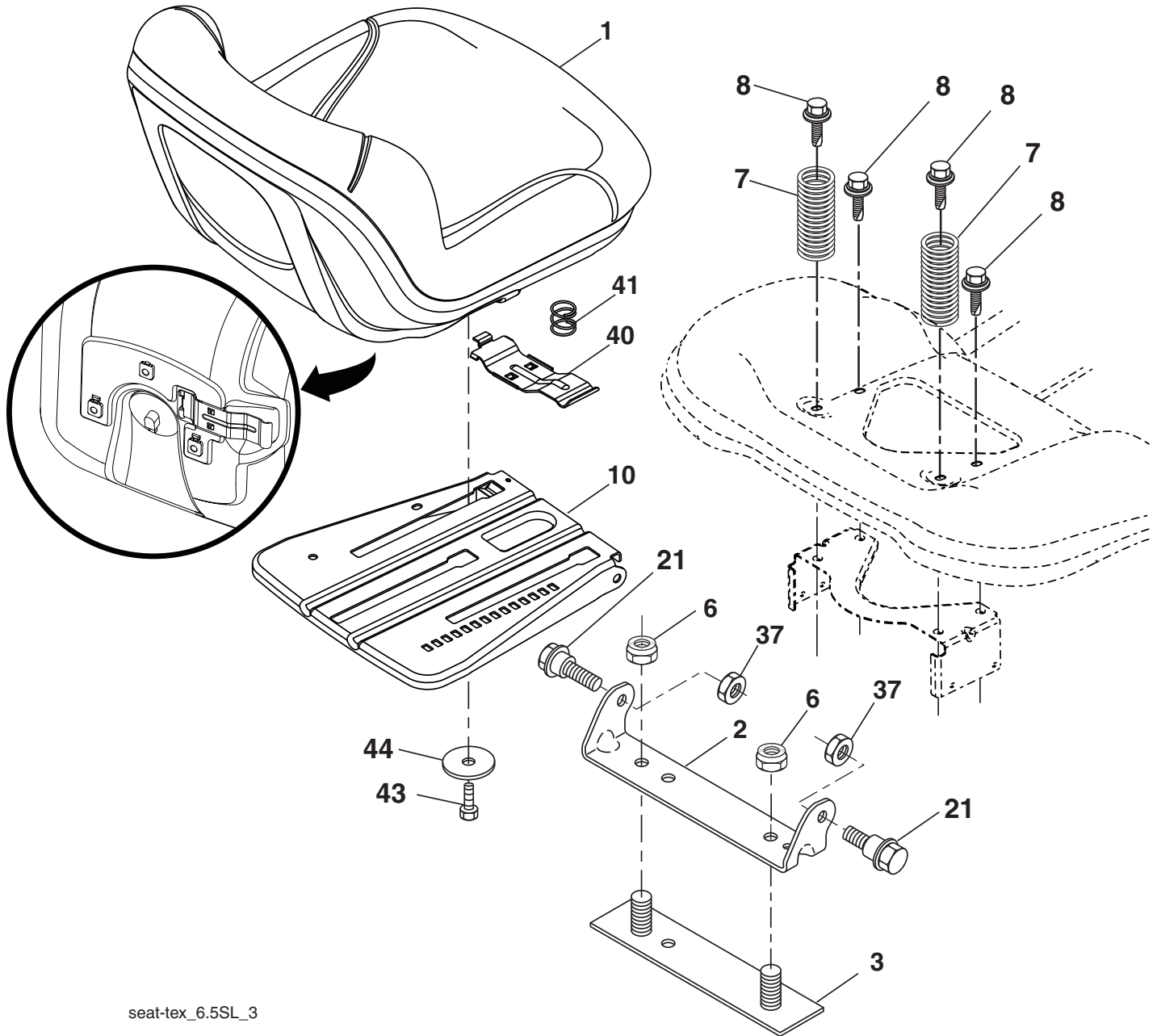

seat-tex_6.5SL_3

KEY NO.	PART NO.	DESCRIPTION
1	532 44 32-63	Seat
2	532 18 01-66	Bracket Pivot Fender
3	532 14 06-75	Strap, Asm Fender
6	873 80 06-00	Nut, Lock w/Ins. 3/8-16 unc
7	532 12 41-81	Spring, Seat Cprsn
8	532 17 18-77	Bolt 5/16-18 unc x 3/4 w/Sems
10	532 19 69-77	Pan, Seat
21	532 17 18-52	Bolt, Shoulder 5/16-18

KEY NO.	PART NO.	DESCRIPTION
37	873 80 05-00	Nut, Lock 5/16-18 unc
40	532 43 98-71	Handle Slide Seat
41	532 19 82-00	Spring Latch Seat
43	874 76 06-12	Bolt Fin Hex 3/8-16 unc x 3/4
44	819 13 38-12	Washer 13/32 x 2-3/8 x 12 Ga.

NOTE: All component dimensions given in U.S. inches
1 inch = 25.4 mm

**TRACTOR - MODEL NO. GTH24V52LS (96043013500), PRODUCT NO. 960 43 01-35
DECALS**

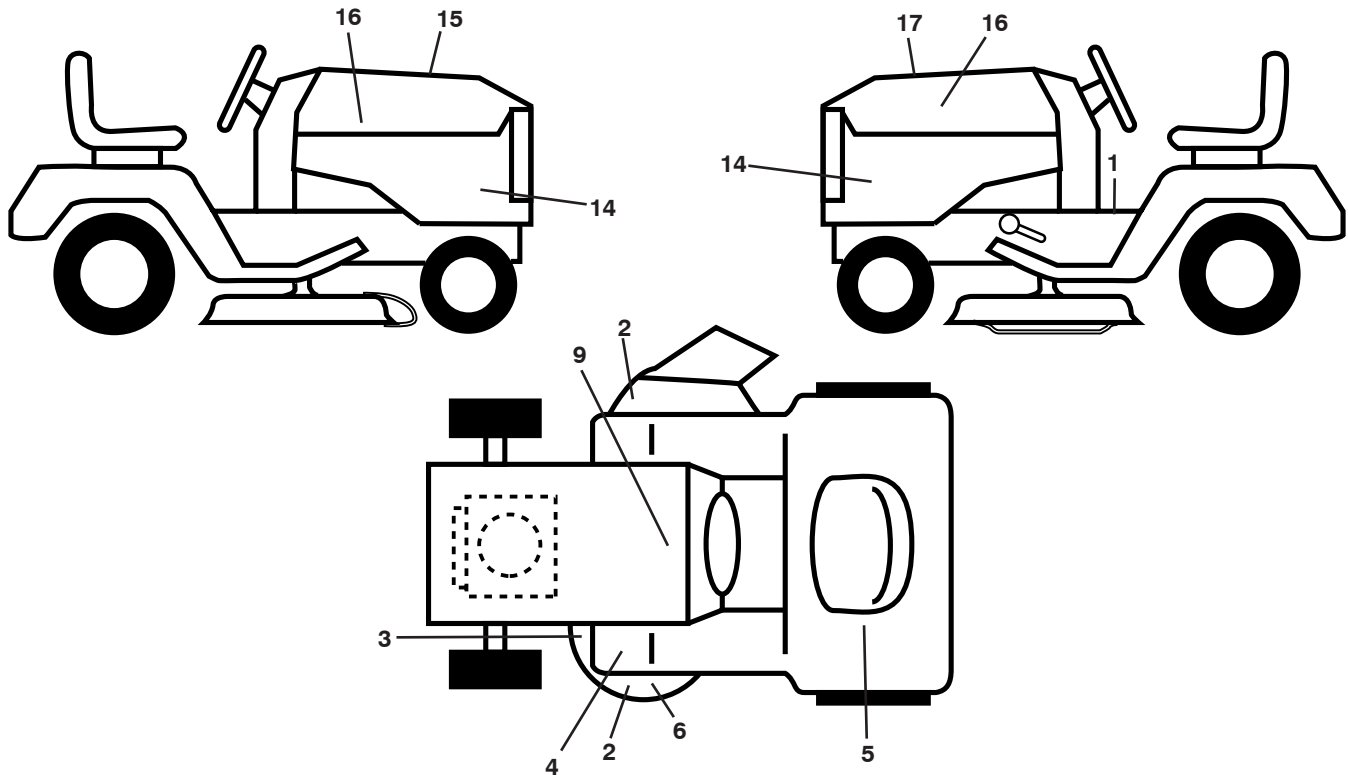

KEY NO.	PART NO.	DESCRIPTION
1	532 41 16-57	Decal, Operator's
2	539 10 57-43	Decal, No Step
3	532 19 87-85	Decal, Mower Sch.
4	532 41 86-00	Decal, Pedal
5	532 42 62-09	Decal, Warning Reserve
6	539 11 32-24	Decal, Warning
9	532 14 50-05	Decal, Battery Dnge/Poi
14	532 44 56-44	Decal, Panel Side

KEY NO.	PART NO.	DESCRIPTION
15	532 42 38-29	Decal, Cust. Resp.
16	532 42 91-96	Decal, Hood Logo
17	532 44 54-99	Decal, Replacement
--	532 16 69-60	Decal, Bypass
--	532 43 98-82	Pad, Footrest, LH
--	532 43 98-81	Pad, Footrest, RH
--	532 44 56-41	Manual, Operator's (Eng/Span)
--	532 44 56-42	Manual, Part's (Eng/Span)

WHEELS AND TIRES

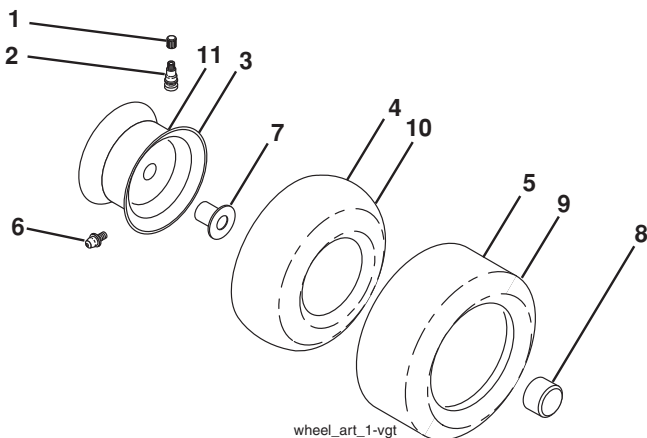

KEY NO.	PART NO.	DESCRIPTION
1	532 05 91-92	Cap, Valve, Tire
2	532 06 51-39	Stem, Valve
3	532 18 18-39	Rim Assembly, Front
4	532 00 81-34	Tube, Front (Service Item Only)
5	532 16 10-24	Tire, Front
6	532 12 49-57	Fitting, Grease (Front Wheel Only)
7	532 12 49-59	Bearing, Flange (Front Wheel Only)
8	532 17 50-39	Cap, Axle (Front Wheel Only)
9	532 17 04-53	Tire, Rear
10	532 00 71-54	Tube, Rear (Service Item Only)
11	532 12 50-70	Rim Assembly, Rear
--	532 14 43-34	Sealant, Tire (10 oz. Tube)

NOTE: All component dimensions given in U.S. inches
1 inch = 25.4 mm

TRACTOR MODELO NO. GTH24V52LS (96043013500), PRODUCTO NO. 960 43 01-35

DIAGRAMA

SCH12-s

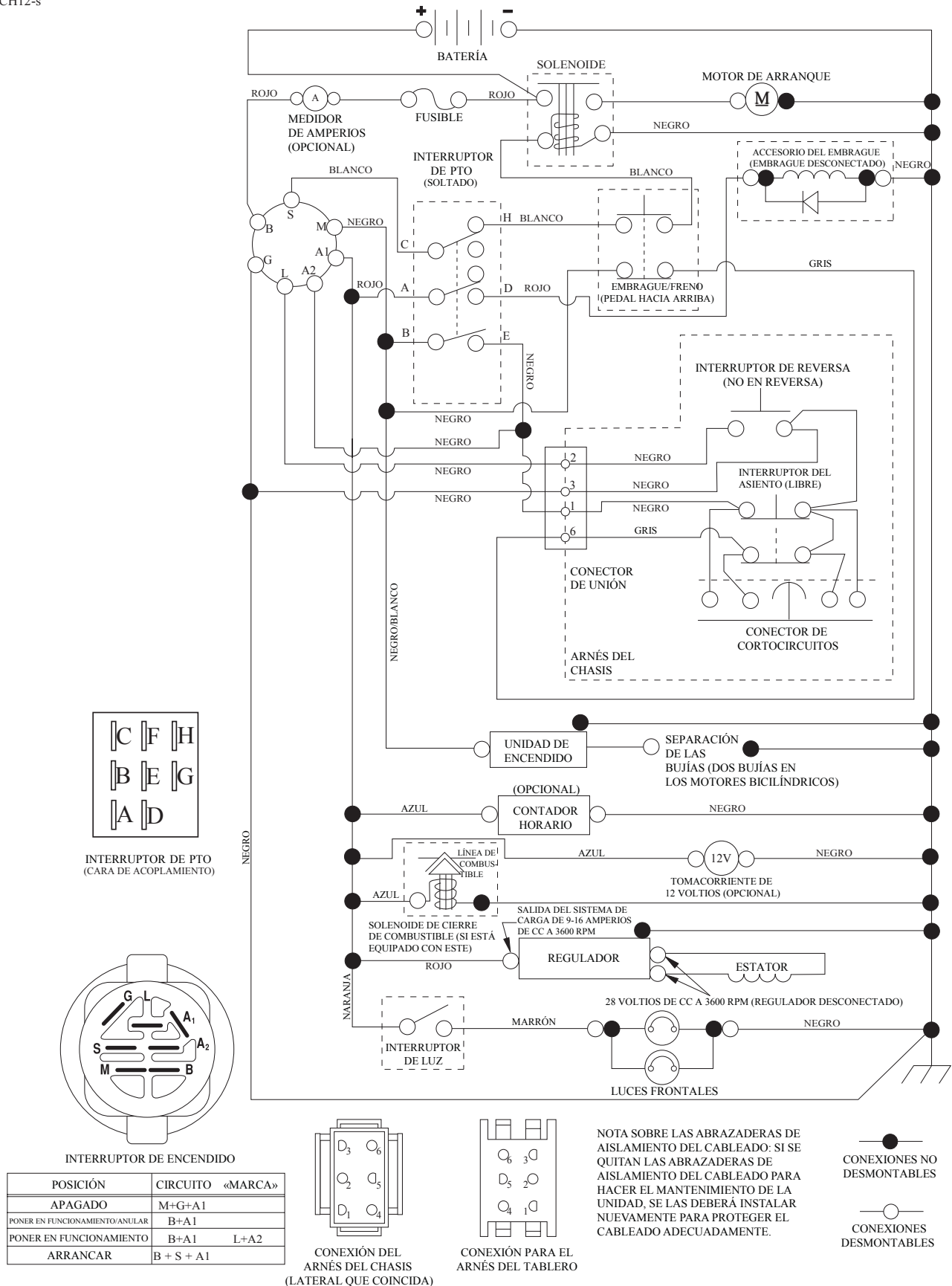

TRACTOR MODELO NO. GTH24V52LS (96043013500), PRODUCTO NO. 960 43 01-35

DIAGRAMA ELÉCTRICO

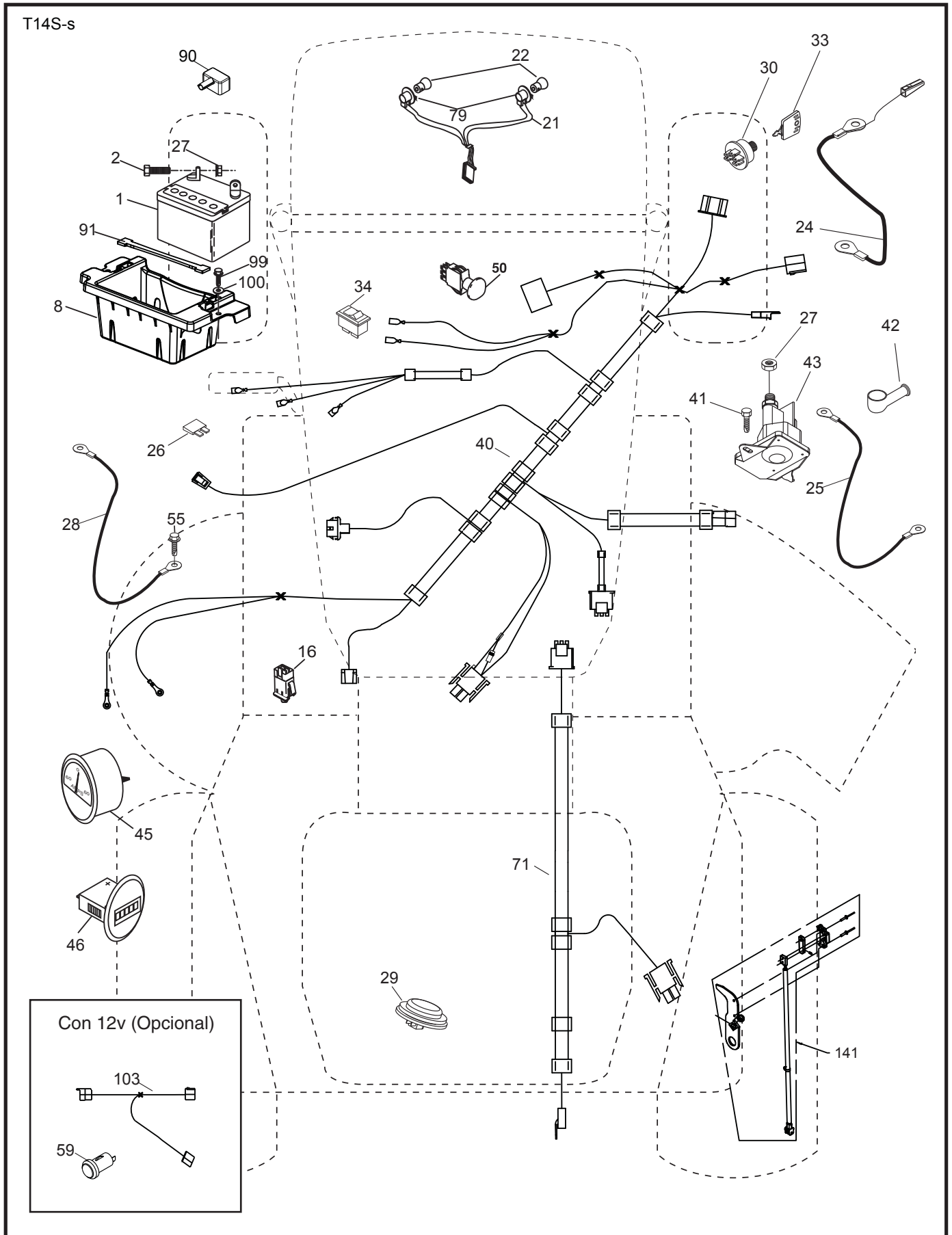

TRACTOR MODELO NO. GTH24V52LS (96043013500), PRODUCTO NO. 960 43 01-35
DIAGRAMA ELÉCTRICO

CÓDIGO NO.	PIEZA NO.	DESCRIPCIÓN
1	532 16 34-65	Batería
2	874 76 04-12	Perno de cabeza hexagonal de 1/4-20 x 3/4
8	532 41 41-25	Caja de la batería
16	532 17 61-38	Interruptor corta corriente a presión
21	532 40 02-52	Cableado del enchufe para la luz
22	532 00 41-52	Bombilla de luz
24	532 40 02-53	Cable
25	532 41 28-95	Cable
26	532 17 51-58	Fusible
27	873 51 04-00	Tuerca hexagonal Keps de 1/4-20 unc
28	532 14 54-91	Cable a tierra
29	532 40 15-45	Interruptor del asiento
30	532 19 33-50	Interruptor de encendido
33	532 41 19-33	Llave/cadena
34	532 11 07-12	Interruptor de luz/de restauración
40	532 40 21-67	Cableado de encendido
41	817 72 04-08	Tornillo
42	532 13 15-63	Cubierta de la terminal
43	532 19 25-07	Solenoide
45	532 42 52-70	Indicador SRVCMNDR
46	532 42 52-71	Indicador HRMTR
50	532 17 46-51	Interruptor
55	817 06 05-12	Tornillo de 5/16-18 x 3/4
59	532 40 03-03	Enchufe, 12V
71	532 19 42-76	Cableado de encendido, chasis
79	532 17 52-42	Enchufe de cierre por torsión del ensamble de la bombilla
90	532 43 53-95	Tapa de los bornes de la batería
91	532 19 02-70	Correa de la batería
99	817 67 04-12	Tornillo 1/4-20 x 3/4
100	819 09 14-16	Arandela
103	532 42 17-47	Cable 12V
141	532 42 12-25	G700/G730 ROS

NOTA: Las dimensiones de todos los componentes están expresadas en pulgadas americanas. 1 pulgada = 25,4 mm

TRACTOR MODELO NO. GTH24V52LS (96043013500), PRODUCTO NO. 960 43 01-35
CHASIS

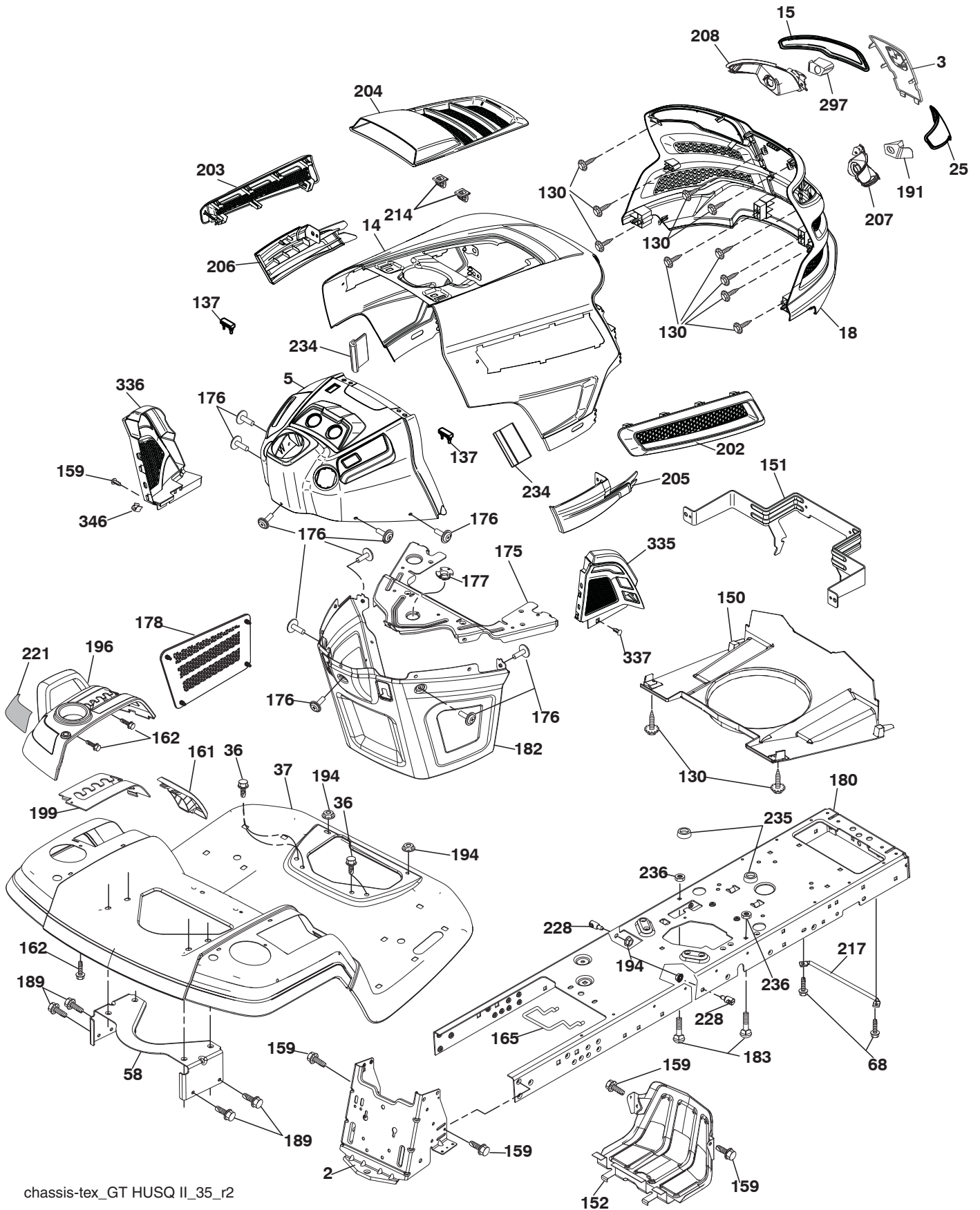

chassis-tex_GT HUSQ II_35_r2

**TRACTOR MODELO NO. GTH24V52LS (96043013500), PRODUCTO NO. 960 43 01-35
CHASIS**

CÓDIGO NO.	PIEZA NO.	DESCRIPCIÓN	CÓDIGO NO.	PIEZA NO.	DESCRIPCIÓN
2	532 19 42-61	Barra de tracción	194	873 90 05-00	Tuerca de presión de 5/16-18
3	532 43 97-52	Applique	196	532 43 96-74	Ensamble de la consola de la plata- forma de elevación
5	532 43 74-70	Tablero	199	532 19 82-59	Chapa
14	532 44 11-77	Capota	202	532 43 97-28	Salida de Ventilación (LD)
15	532 43 97-33	Lente izquierdo de la parrilla	203	532 43 97-27	Salida de Ventilación (LI)
18	532 43 77-62	Parrilla (incluye códigos No. 15, 25, 191)	204	532 43 57-14	Salida de Ventilación superior
25	532 44 33-85	Lente derecho de la parrilla	205	532 43 97-30	Camisa de Capota (LD)
36	817 06 05-12	Tornillo de 5/16-18 x 3/4	206	532 43 97-29	Camisa de Capota (LI)
37	532 44 12-08	Guardabarros	207	532 43 97-34	Bisel derecho
58	532 19 43-14	Soporte de Guardabarros	208	532 43 97-35	Bisel izquierdo
68	817 49 05-08	Tornillo de 5/16-18 x 1/2	214	532 19 91-45	Cierre
130	532 41 63-58	Tornillo No. 10 x 0,75	217	532 40 91-67	Varilla giratoria
137	532 40 75-90	Cubierta Tablero	218	532 19 63-95	Tope
150	532 43 97-74	Cubierta	221	532 19 89-09	Reflector (LI)
151	532 43 66-70	Soporte de Capota	228	532 19 51-61	Sujetador del travesaño
152	532 43 98-70	Protector contra oscurecimiento	234	532 40 47-42	Tope de la capilla
159	817 00 06-12	Tornillo 3/8-16 x 3/4	235	532 40 61-29	Separador del guardabarros
161	532 43 99-29	Ventanilla de combustible	236	873 93 05-00	Tuerca de presión 5/16-18 unc
162	532 14 24-32	Tornillo	297	532 43 74-56	Parte movable reflexivo (LI)
165	532 19 43-30	Soporte de Tanque de Gasolina	335	532 43 98-47	Cubierta (LD)
175	532 19 63-04	Travesaño	336	532 44 53-09	Cubierta (LI)
176	532 40 07-76	Tornillo de 10-24 x 5/8	337	532 43 81-37	Sujetador
177	532 19 52-27	Buje de dirección	346	532 12 64-71	Sujetador aislado
178	532 19 97-82	Red de cargo	- -	532 42 49-18	Protector del cepillo
180	532 19 42-60	Chasis			
182	532 40 68-59	Tablero inferior			
183	874 52 05-20	Perno 5/16-18 x 1-1/4			
189	817 00 05-12	Tornillo			
191	532 43 74-55	Parte movable reflexivo (LD)			

NOTA: Las dimensiones de todos los componentes están expresadas en pulgadas americanas. 1 pulgada = 25,4 mm

TRACTOR MODELO NO. GTH24V52LS (96043013500), PRODUCTO NO. 960 43 01-35
TRANSMISIÓN

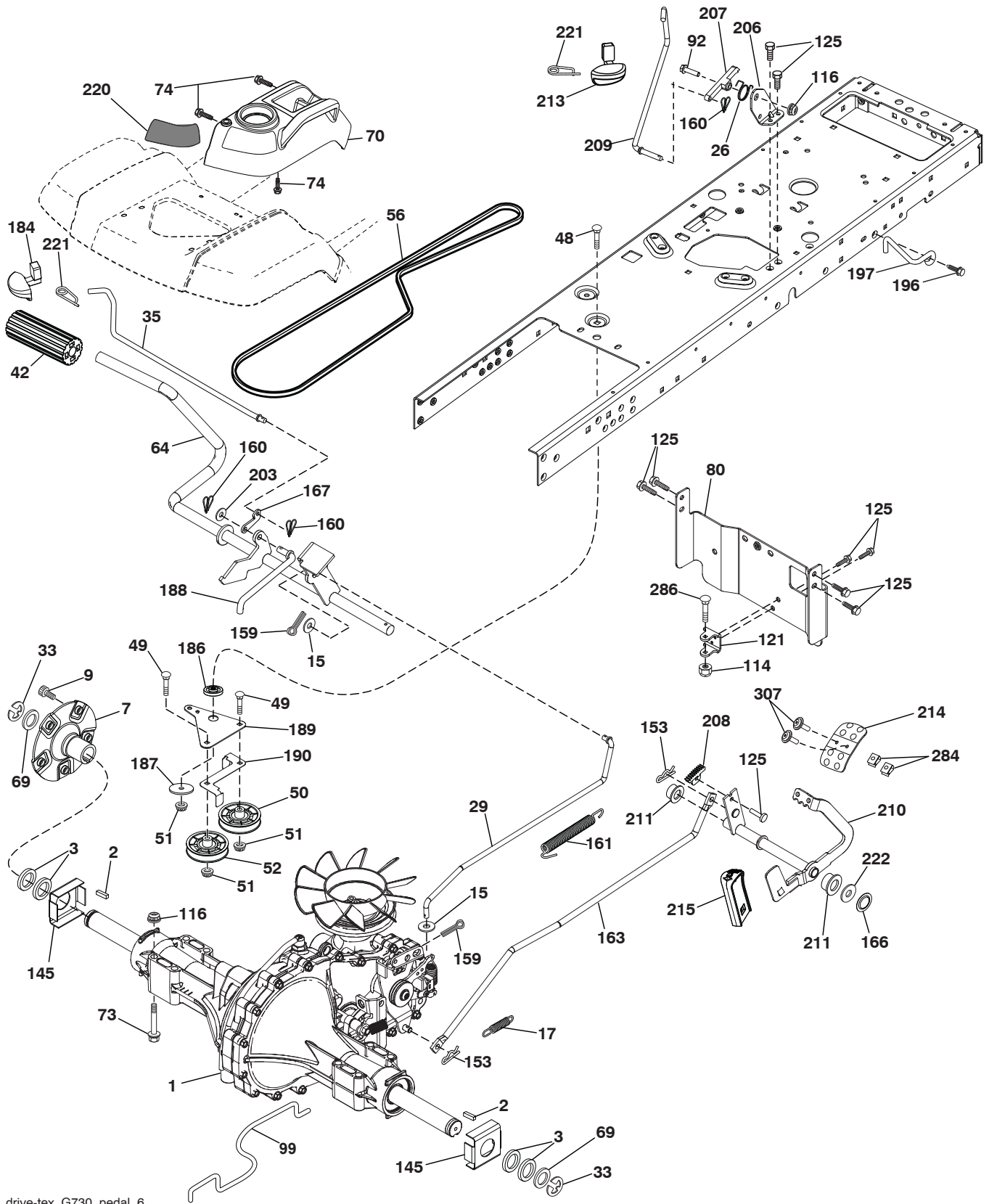

drive-tex_G730_pedal_6

TRACTOR MODELO NO. GTH24V52LS (96043013500), PRODUCTO NO. 960 43 01-35

TRANSMISIÓN

CÓDIGO NO.	PIEZA NO.	DESCRIPCIÓN	CÓDIGO NO.	PIEZA NO.	DESCRIPCIÓN
1	-----	Transeje, Hydro G7-BCBB-1XDC-1FCA (420331)(Haga el pedido de las piezas al fabricante del transeje.)	161	532 10 57-09	Resorte de retorno del embrague
2	532 00 70-70	Llave	163	532 41 81-85	Control del pedal de la barra
3	532 00 75-63	Tuerca	166	532 42 91-64	Tuerca
7	532 19 98-37	Ensamble del cubo trasero	167	532 40 52-57	Pestillo del freno de mano
9	532 14 00-80	Perno	184	532 44 14 55	Manija del freno de mano
15	819 13 13-16	Arandela 13/32 x 13/16 x calibre 16	186	532 19 43-21	Espaciador de retención
17	532 19 72-96	Resorte de freno	187	819 13 32-10	Arandela
26	532 19 96-79	Resorte de travesía	188	532 19 43-23	Mecanismo de desplazamiento de la varilla de mando del embrague
29	532 41 81-86	Varilla del freno	189	532 40 75-04	Palanca acodada del mecanismo de desplazamiento
33	812 00 00-53	Aro "E"	190	532 40 75-05	Sujetador de la palanca acodada del mecanismo de desplazamiento
35	532 43 54-86	Varilla del freno de mano	196	817 00 06-16	Tornillo 3/8-16 x 1
42	532 12 48-72	Cubierta del pedal	197	532 19 97-69	Mecanismo de desplazamiento
48	872 11 06-12	Tornillo 3/8-16 x 1-1/2 Gr.5	203	819 11 11-16	Tuerca 11/32 x 11/16 x calibre 16
49	872 11 06-14	Perno	206	532 19 78-67	Soporte de la travesía
50	532 19 43-27	Polea loca plana	207	532 19 78-68	Cierre del control de travesía
51	873 90 06-00	Tuerca de presión de 3/8-16	208	532 19 78-69	Travesía del control del sector
52	532 19 43-26	Polea loca con ranura en V con un desplazamiento	209	532 19 95-92	Travesía del control de Rod
56	532 42 08-07	Correa trapezoidal de la transmisión	210	532 19 78-60	Ensamble del eje de balancín. Control del pedal
64	532 19 78-65	Ensamble del eje Control del pedal de freno	211	532 12 01-83	Buje
69	532 12 38-00	Tuerca 1-1/32 x 1-5/8 x calibre 16	213	532 40 31-19	Travesía del control de la perilla
70	532 43 96-61	Ensamble de la consola	214	532 41 68-63	Pedal adelante
73	874 49 05-48	Perno 5/16-18 3.75	215	532 40 17-23	Revés del pedal
74	532 14 24-32	Tornillo 1/4 x 1/2	220	532 19 89-08	Reflector derecho
80	532 41 81-84	Correa de torsión	221	532 40 31-87	Abrazadera de retención del resorte de la manija
92	874 76 05-20	Tornillo 5/16-18 x 1/2	222	879 21 20-10	Tuerca 21/32 x 1-1/4 x calibre 10
99	532 41 81-88	Varilla de desviación	284	532 41 76-93	Tuerca 1/4-20
114	873 80 05-00	Tuerca 5/16-18 unc	286	872 01 05-20	Tornillo 5/16-18 x 2.50
116	873 90 05-00	Tuerca 5/16-18	307	874 18 04-12	Tornillo 1/4-20 x 3/4
121	532 17 56-11	Bracket Strap Torque			
125	817 00 05-12	Tornillo 5/16-18 x 3/4			
145	532 16 31-68	Tuerca			
153	532 12 47-88	Retén del resorte			
159	876 02 04-12	Pasador de chaveta de 1/8 x 3/4			
160	532 16 94-84	Abrazadera de retención			

NOTA: Las dimensiones de todos los componentes están expresadas en pulgadas americanas. 1 pulgada = 25,4 mm

TRACTOR MODELO NO. GTH24V52LS (96043013500), PRODUCTO NO. 960 43 01-35
MOTOR

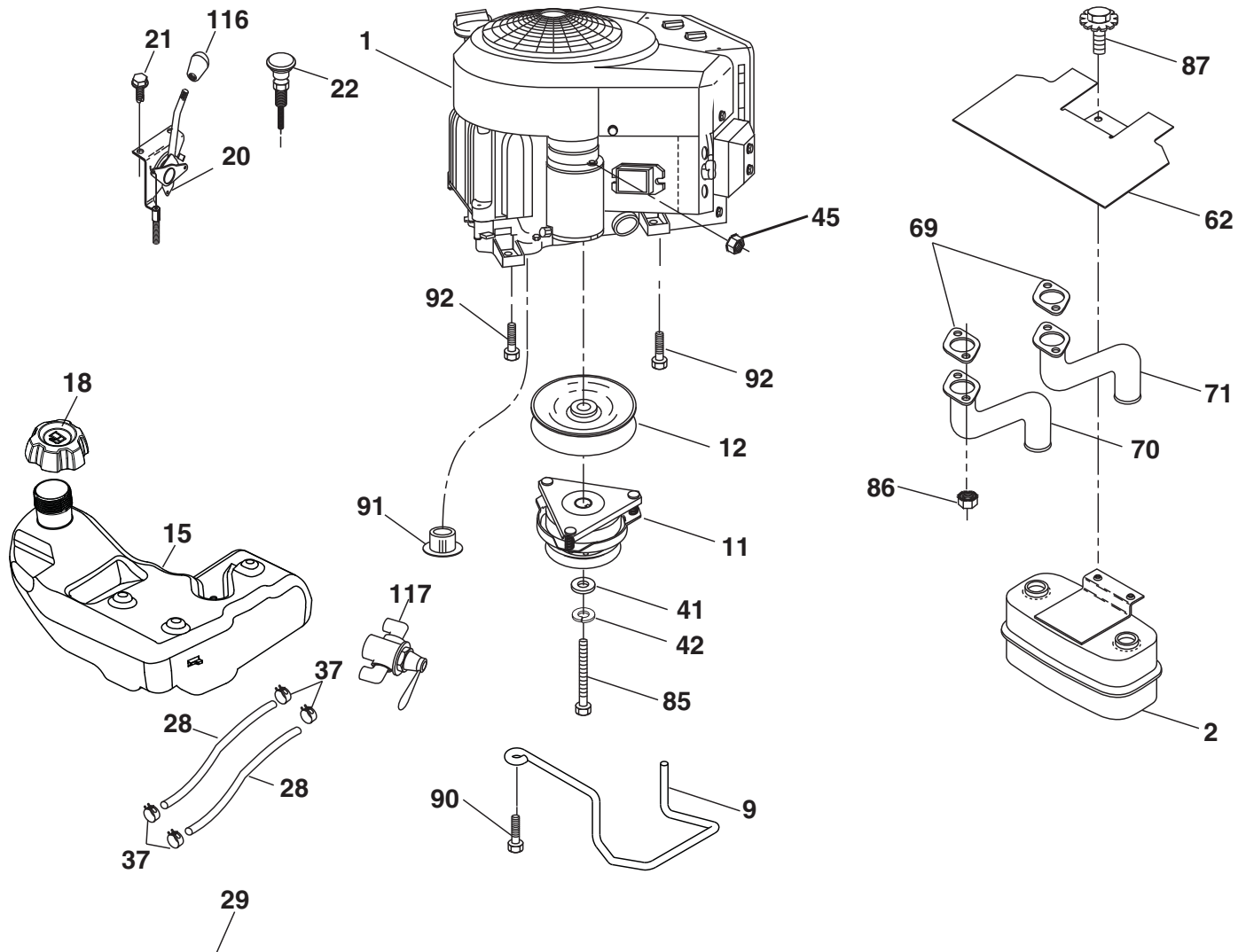

EQUIPO APAGACHISPAS

engine-tex_Kawa-2cyl_9

**TRACTOR MODELO NO. GTH24V52LS (96043013500), PRODUCTO NO. 960 43 01-35
MOTOR**

CÓDIGO NO.	PIEZA NO.	DESCRIPCIÓN
1	-----	Motor KAWA modelo No. FR730V-DS04 (445363)(Haga el pedido de las piezas al fabricante del motor.)
2	532 14 97-23	Silenciador
9	532 40 86-67	Ensamble del sujetador de la correa del motor
11	532 17 93-35	Embrague de eléctrico
12	532 19 43-43	Polea del motor
15	532 42 29-48	Tanque de Gasolina de 4,0R
18	532 43 92-08	Tapa
20	532 42 43-41	Control del regulador
21	532 41 63-58	Tornillo No. 10 x 0,75 con rosca reforzada
22	532 19 15-96	Control de la estrangulación del motor
28	532 40 11-35	Línea de combustible
29	532 13 71-80	Equipo apagachispas
37	532 12 34-87	Abrazadera de la manguera
41	532 12 61-97	Arandela 1-1/2 x 15/32 x .250
42	810 04 07-00	Arandela de presión de 7/16
45	873 51 04-00	Tuerca
62	532 14 66-29	Silenciador con pantalla térmica
69	532 17 81-51	Junta
70	532 15 99-55	Tubo de escape izquierdo
71	532 16 05-89	Tubo de escape derecho
85	532 17 99-53	Perno de 7/16-20 x 3.75 Gr. 5
86	532 18 43-62	Tuerca
87	532 19 82-39	Perno de 5/16-18 unc x 1
90	817 00 06-16	Tornillo de 3/8-16 x 1
91	532 18 74-95	Buje
92	817 12 06-16	Tornillo 3/8-16 x 1
116	539 13 26-24	Tacto suave de la perilla
117	532 42 08-28	válvula de la reserva del combustible

NOTA: Las dimensiones de todos los componentes están expresadas en pulgadas americanas. 1 pulgada = 25,4 mm
Para las piezas del servicio y de recambio del motor, llame el número gratis para su fabricante del motor enumerado abajo:
Kawasaki 1-949-460-5688

TRACTOR MODELO NO. GTH24V52LS (96043013500), PRODUCTO NO. 960 43 01-35
ENSAMBLE DE LA DIRECCIÓN

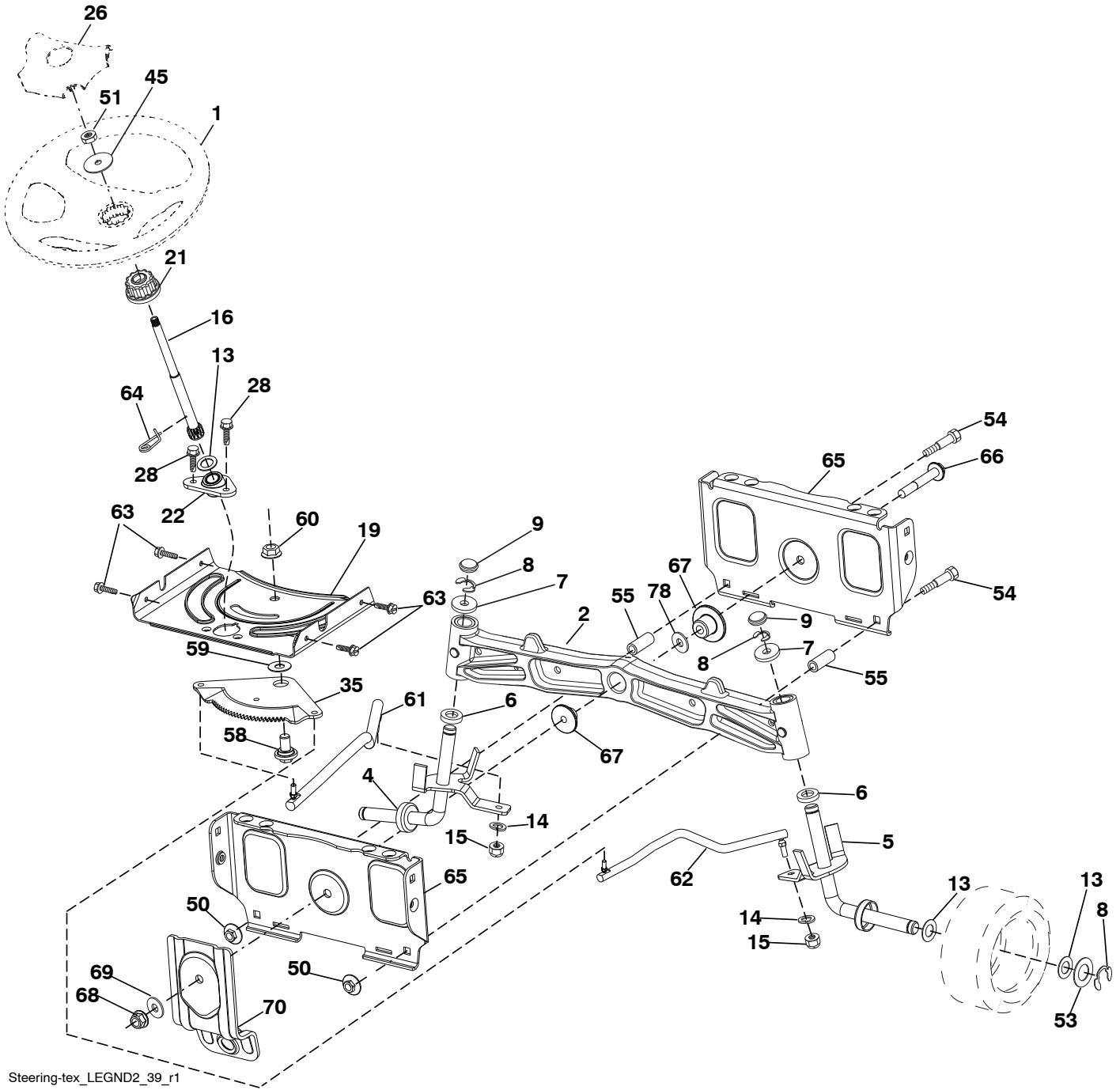

Steering-tex_LEGND2_39_r1

**TRACTOR MODELO NO. GTH24V52LS (96043013500), PRODUCTO NO. 960 43 01-35
ENSAMBLE DE LA DIRECCIÓN**

CÓDIGO NO.	PIEZA NO.	DESCRIPCIÓN
1	532 43 97-40	Volante de dirección
2	532 19 59-68	Ensamble del eje delantero
4	532 40 30-89	Ensamble del husillo izquierdo
5	532 40 30-90	Ensamble del husillo derecho
6	532 12 49-31	Pista del rodamiento para reforzar el impulso
7	532 12 17-48	Arandela de 25/32 x 1-5/8 calibre 16
8	812 00 00-29	Abrazadera del aro No. T5304-75
9	532 12 12-32	Tapa del husillo
13	532 12 17-49	Arandela de 25/32 x 1-1/4 calibre 16
14	810 04 06-00	Arandela de presión de 3/8
15	873 54 06-00	Tuerca de 3/8-24 unf
16	532 40 82-19	Eje de dirección
19	532 19 47-29	Placa de dirección
21	532 18 67-37	Adaptador del volante de dirección
22	532 42 05-37	Dirección apoyo inferior
26	532 43 97-43	Inserto del volante de dirección
28	817 00 06-12	Tornillo de 3/8-16 x 3/4
35	532 19 47-32	Engranaje del sector de la placa
45	819 18 38-12	Arandela de 9/16 ID x 2-3/8 x calibre 12
50	873 90 06-00	Tuerca 3/8-16 unc
51	873 94 08-00	Contratuerca hexagonal de seguridad de 1/2-20 unf
53	532 18 89-67	Arandela reforzada de, 793 x 1,637 x 0,060
54	874 76 06-36	Tornillo 3/8-16 unc x 2-1/4
55	532 41 47-36	Tornillo 3/8-16 unc x 2-1/4
58	532 19 47-47	Perno de tope del sector del pivote CFM
59	532 19 47-48	Arandela de empuje del sector de dirección
60	873 97 10-00	Tuerca de 5/8-11
61	532 19 47-40	Barra de acoplamiento izquierda
62	532 19 47-41	Barra de acoplamiento derecha
63	817 00 05-12	Tornillo de 5/16-18 x 3/4
64	532 19 98-49	Abrazadera de retención del resorte de la dirección
65	532 19 47-34	Apoyo del árbol delantero
66	871 02 07-48	Perno de cabeza hexagonal con brida acanalada de 7/16-14 x 3
67	532 19 47-37	Buje PM del eje delantero
68	873 90 07-00	Tuerca de 7/16-14 grado 5
69	532 19 91-62	Arandela de 1,5 x 0,505 x 0,118
70	532 19 61-97	Soporte de la plataforma delantera
78	532 05 70-79	Tuerca

NOTA: Las dimensiones de todos los componentes están expresadas en pulgadas americanas. 1 pulgada = 25,4 mm

TRACTOR MODELO NO. GTH24V52LS (96043013500), PRODUCTO NO. 960 43 01-35
PLATAFORMA DE LA CORTADORA DE CÉSPED

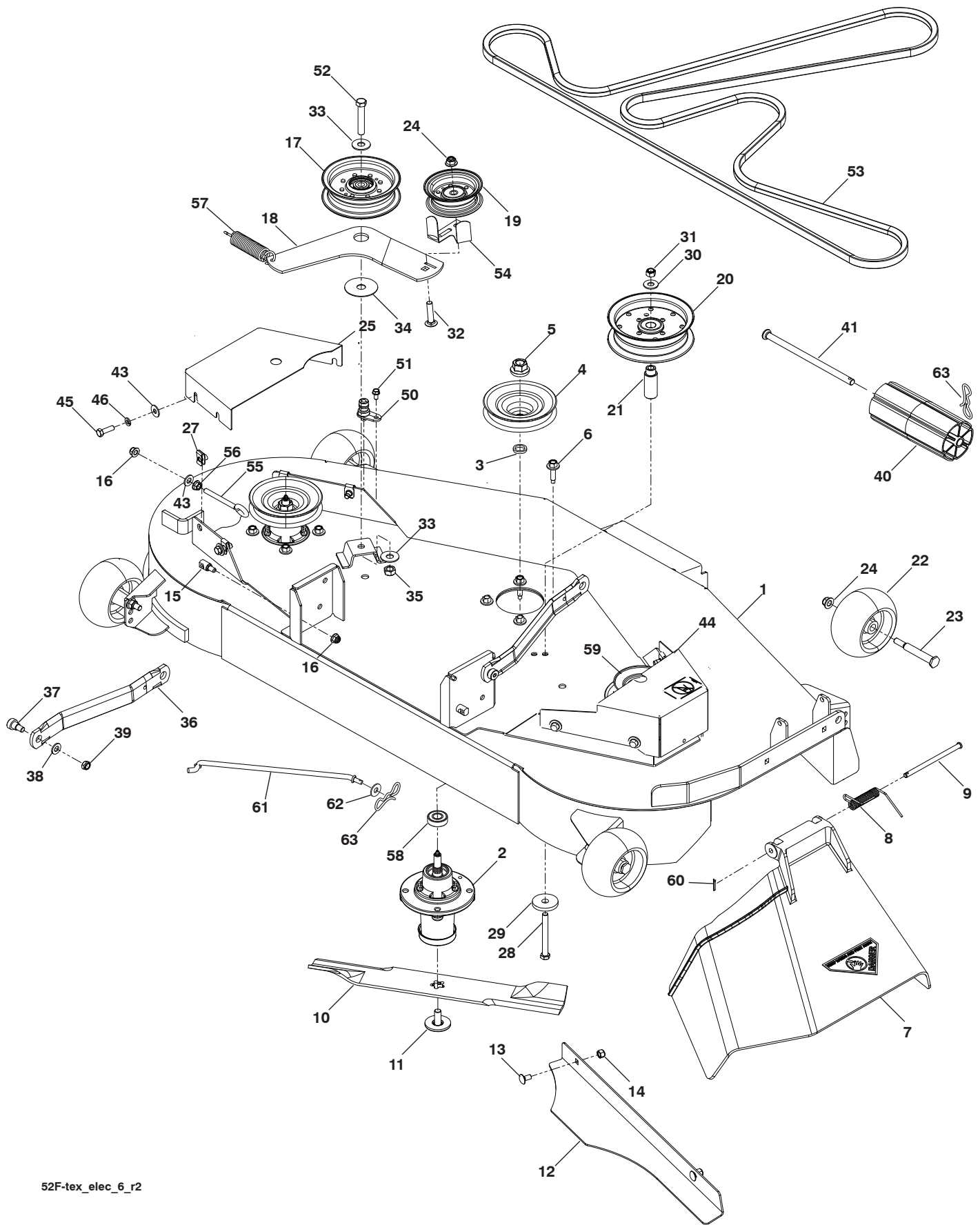

52F-tex_elec_6_r2

**TRACTOR MODELO NO. GTH24V52LS (96043013500), PRODUCTO NO. 960 43 01-35
PLATAFORMA DE LA CORTADORA DE CÉSPED**

CÓDIGO NO.	PIEZA NO.	DESCRIPCIÓN	CÓDIGO NO.	PIEZA NO.	DESCRIPCIÓN
1	532 44 53-60	Cubierta	37	539 11 36-21	Sb 3/8-16 x 3/8 Skt Hd
2	539 11 21-70	Ensamble de la cubierta	38	539 99 01-22	Arandela 3/8
3	539 18 76-90	Arandela	39	539 20 02-82	Tuerca 3/8-16
4	532 10 75-21	Polea	40	532 17 60-66	Rodillo de la nariz
5	539 40 02-34	Tuerca 9/16	41	532 17 91-27	Rod, rodillo de la nariz
6	539 10 76-30	Tornillo	43	539 99 06-92	Arandela 5/16
7	539 11 07-33	Canal inclinado de la descarga	44	575 32 00-02	Protector de la correa LD
8	539 11 07-35	Resorte - torsión	45	539 99 02-09	Hcs 5/16-18 x 1 Gr 5
9	539 11 07-36	Clavija de horquilla 5/16 x 5.19	46	539 99 01-87	Arandela 5/16
10	574 87 08-01	Lámina, 16-1/4"	50	532 41 55-98	Puerto del derrubio
11	539 10 75-22	Perno, 7/16	51	539 10 84-61	Perno 1/4-20 x 1/2
12	574 87 50-02	Placa del confinamiento	52	539 10 48-70	Hcs 7/16-14 x 2-1/2 Gr 5
13	539 99 07-99	Rhsnb 5/16-18 x 5/8 Gr 5	53	574 84 56-03	Correa, cubierta
14	539 99 07-17	Tuerca 5/16-18	54	575 22 43-01	Protector, correa
15	532 19 51-61	Sujetador del perno prisionero	55	539 11 55-74	Perno de argolla 5/16 x 3-1/2
16	539 11 28-99	Tuerca 5/16-18	56	539 99 05-85	Tuerca 5/16-18
17	532 19 61-04	Polea más ociosa	57	539 10 68-50	Resorte
18	574 84 18-02	Brazo más ocioso	58	539 11 20-50	Rodamiento de bolitas
19	532 17 79-68	Polea más ociosa	59	575 35 29-01	Polea
20	539 13 27-28	Polea más ociosa	60	532 16 94-84	Detenedor del clip
21	575 22 45-01	Buje más ocioso	61	532 40 48-51	Varilla
22	539 10 76-10	Rueda, calibrador	62	819 13 13-12	Arandela 13/32 x 13/16 x calibre 12.
23	532 19 34-06	Perno	63	532 19 42-08	Pasador de chaveta de 5/16 con bloqueo en forma de mariposa
24	521 99 65-01	Tuerca 3/8-16	--	532 44 53-61	Cubierta del cortacéspedes completa
25	575 22 47-02	Protector, correa LI			
27	539 10 47-63	Detenedor 5/16			
28	539 10 82-71	Hcs 3/8-16 x 3-1/2 Gr 5			
29	539 10 65-04	Arandela			
30	539 99 05-17	Arandela 3/8			
31	539 97 69-79	Tuerca 3/8-16			
32	539 99 09-23	Rhsnb 3/8-16 x 1-3/4 Gr 5			
33	539 10 48-64	Arandela 7/16 Flat			
34	532 17 85-15	Arandela			
35	539 11 91-24	Tuerca 7/16-14			
36	532 19 51-85	Suspensión posterior del brazo			

NOTA: Las dimensiones de todos los componentes están expresadas en pulgadas americanas. 1 pulgada = 25,4 mm

**TRACTOR MODELO NO. GTH24V52LS (96043013500), PRODUCTO NO. 960 43 01-35
ELEVACIÓN DE LA CORTADORA DE CÉSPED**

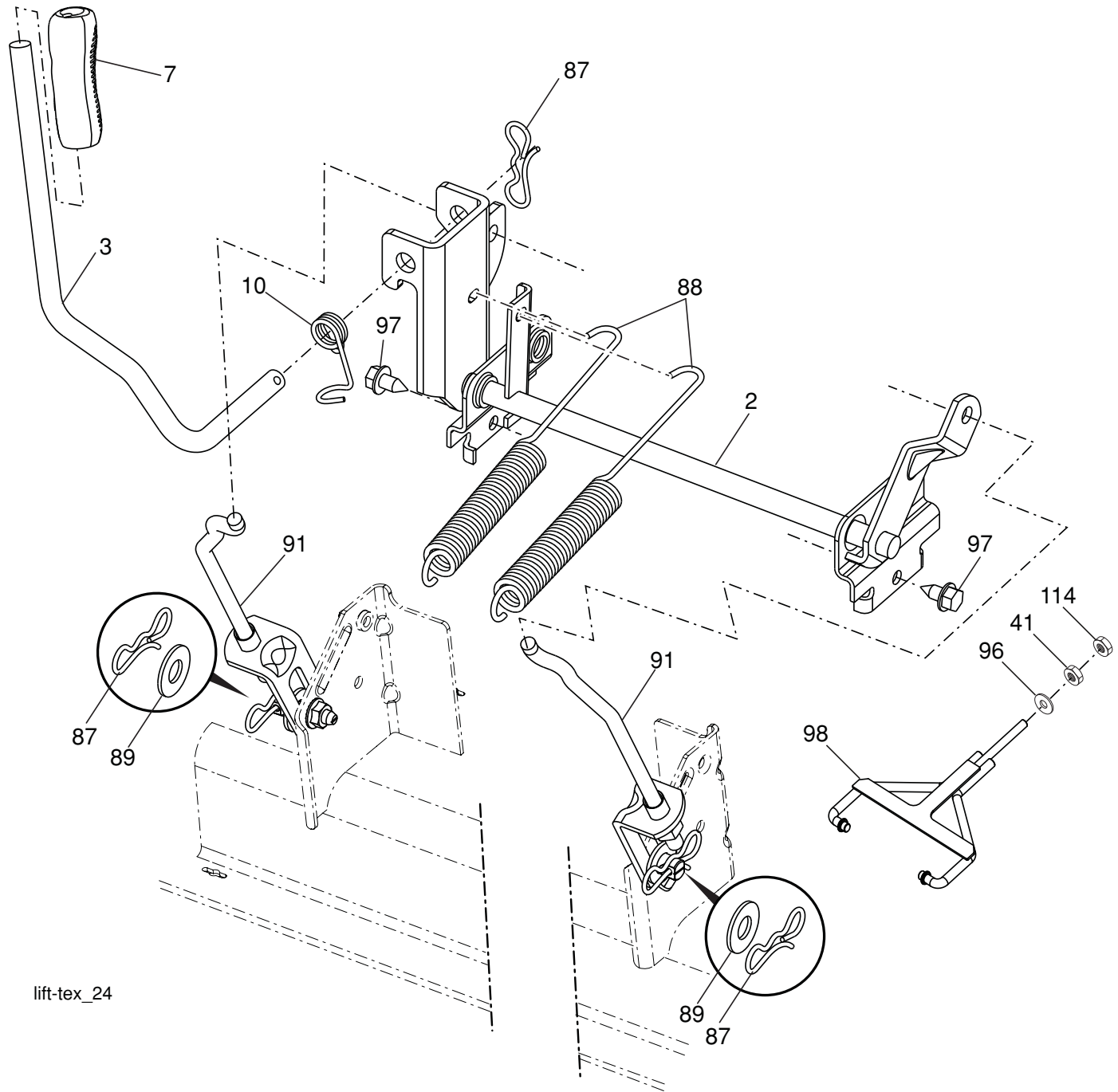

lift-tex_24

CÓDIGO NO.	PIEZA NO.	DESCRIPCIÓN
2	532 42 20-27	Ensamble del eje de la elevación
3	532 19 52-30	Ensamble de la palanca de elevación derecha
7	532 41 17-42	Mango de la palanca
10	532 19 63-14	Resorte de torsión
41	532 17 59-94	Tuerca
87	532 19 42-09	Pasador de chaveta de 7/16 con bloqueo en forma de mariposa
88	532 19 53-04	Resorte de ayuda de la elevación
89	819 19 19-12	Arandela de zinc transparente

CÓDIGO NO.	PIEZA NO.	DESCRIPCIÓN
91	532 40 34-07	Ensamble del acoplamiento Elevación trasera
96	532 19 52-63	Buje
97	817 00 06-12	Tornillo de 3/8-16 x 0,75
98	574 82 25-01	Acoplamiento frontal de la elevación de la cortadora de césped
114	873 36 07-00	Tuerca 7/16-20

NOTA: Las dimensiones de todos los componentes están expresadas en pulgadas americanas. 1 pulgada = 25,4 mm

**TRACTOR MODELO NO. GTH24V52LS (96043013500), PRODUCTO NO. 960 43 01-35
ENSAMBLE DEL ASIENTO**

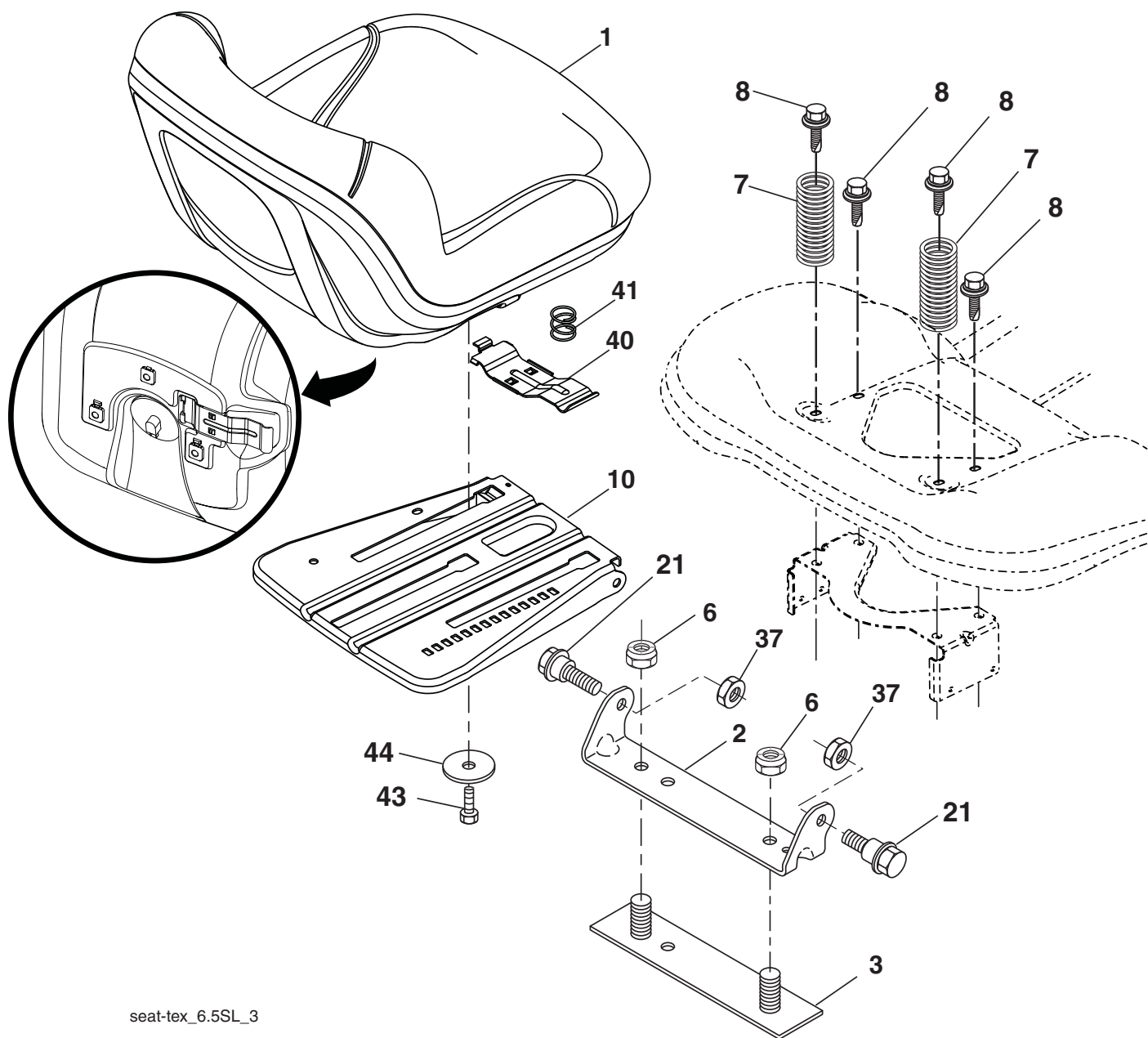

seat-tex_6.5SL_3

CÓDIGO NO.	PIEZA NO.	DESCRIPCIÓN
1	532 44 32-63	Asiento
2	532 18 01-66	Soporte pivotante del guardabarros
3	532 14 06-75	Conector del ensamble del guardabarros
6	873 80 06-00	Tuerca de presión c/aislamiento de 3/8-16 unc
7	532 12 41-81	Resorte del asiento
8	532 17 18-77	Perno de 5/16" unc x 3/4"
10	532 19 69-77	Bandeja del asiento
21	532 17 18-52	Perno de tope de 5/16-18

CÓDIGO NO.	PIEZA NO.	DESCRIPCIÓN
37	873 80 05-00	Tuerca de presión de 5/16-18 unc
40	532 43 98-71	Manija para deslizar el asiento
41	532 19 82-00	Resorte para trabar el asiento
43	874 76 06-12	Perno de cabeza hexagonal con aleta de 3/8-16 unc x 3/4
44	819 13 38-12	Arandela de 13/32 x 2-3/8 calibre 12

NOTA: Las dimensiones de todos los componentes están expresadas en pulgadas americanas. 1 pulgada = 25,4 mm

TRACTOR MODELO NO. GTH24V52LS (96043013500), PRODUCTO NO. 960 43 01-35

CALCOMANÍAS

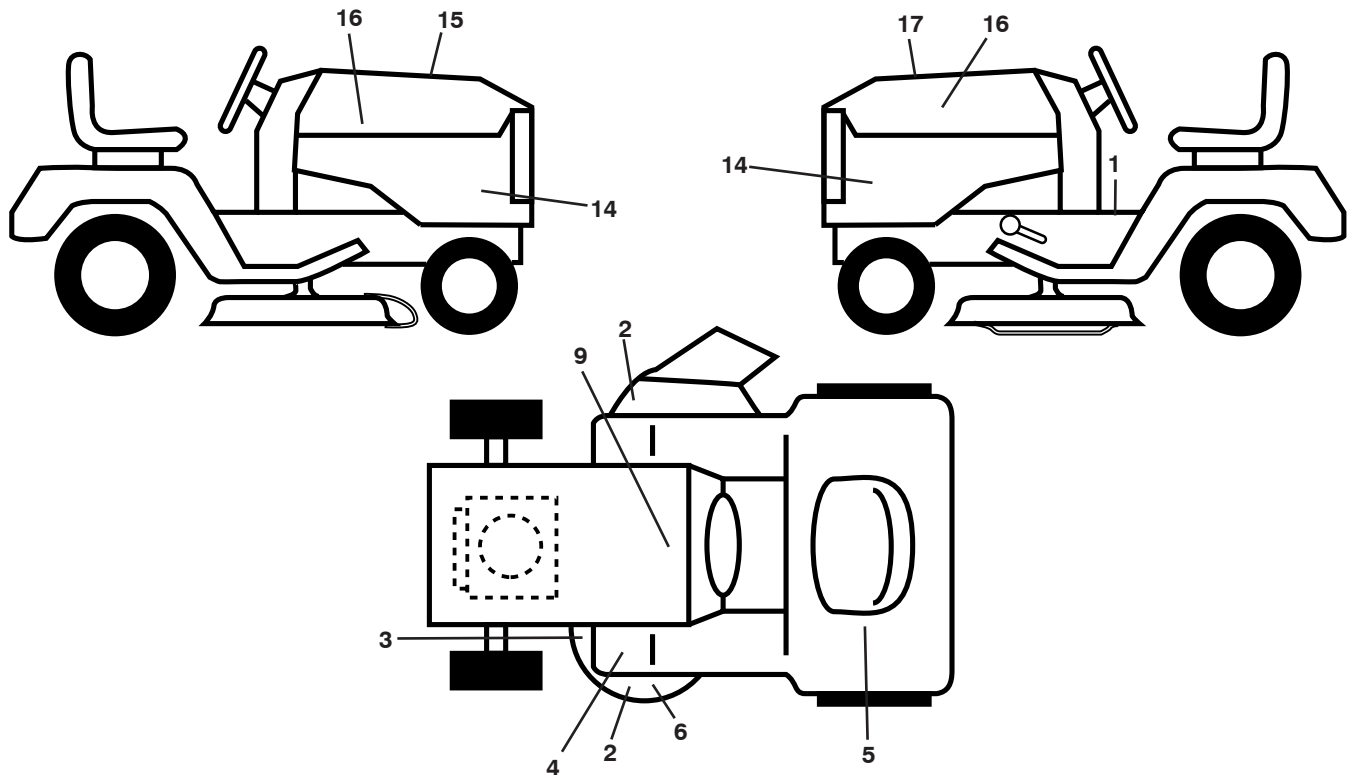

CÓDIGO NO.	PIEZA NO.	DESCRIPCIÓN
1	532 41 16-57	Calcomanía, Operador
2	539 10 57-43	Calcomanía, Ningún paso
3	532 19 87-85	Calcomanía del diagrama de la cortadora de césped
4	532 41 86-00	Calcomanía, Pedal
5	532 42 62-09	Calcomanía, Cuidado
6	539 11 32-24	Calcomanía, Advertencia
9	532 14 50-05	Calcomanía de Peligro/Punto de interconexión
14	532 44 56-44	Calcomanía, Panel

CÓDIGO NO.	PIEZA NO.	DESCRIPCIÓN
15	532 42 38-29	Calcomanía
16	532 42 91-96	Calcomanía para la capota, logo
17	532 44 54-99	Calcomanía de reemplazo
--	532 16 69-60	Calcomanía para la desviación
--	532 43 98-82	Forro del apoyo para los pies izquierdo
--	532 43 98-81	Forro del apoyo para los pies derecho
--	532 44 56-41	Manual del operario (ESP/ING)
--	532 44 56-42	Manual del repuestos (ESP/ING)

WHEELS AND TIRES

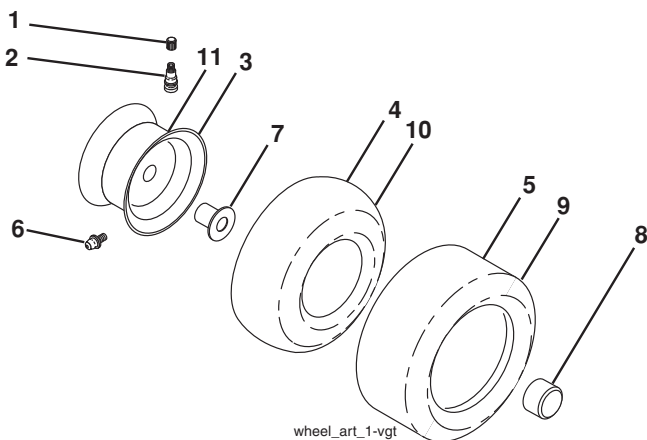

CÓDIGO NO.	PIEZA NO.	DESCRIPCIÓN
1	532 05 91-92	Tapa de la válvula del neumático
2	532 06 51-39	Vástago de la válvula
3	532 18 18-39	Ensamble de las llantas delanteras
4	532 00 81-34	Cámara delantera
5	532 16 10-24	Neumático delantero
6	532 12 49-57	Accesorio para engrasar (solo para la rueda delantera)
7	532 12 49-59	Rodamiento de la brida (solo para la rueda delantera)
8	532 17 50-39	Tapa del eje (solo para la rueda delantera)
9	532 17 04-53	Neumático trasero
10	532 00 71-54	Cámara trasera (Mantenimiento sólo)
11	532 12 50-70	Ensamble trasero de la llanta
--	532 14 43-34	Sellador para neumáticos (tubo de 10 onzas [283 gr])

NOTA: Las dimensiones de todos los componentes están expresadas en pulgadas americanas. 1 pulgada = 25,4 mm

NOTES/AVISO

08/23/2011 BD