

532 44 57-33 Rev. 1



Repair Parts Manual IPL Manual

YTA19K42/96045003300

Please read the operator's manual carefully and make sure you understand the instructions before using the machine.

Por favor lea cuidadosamente y comprenda estas intrucciones antes de usar esta maquina.



English/Only

HOW TO USE THIS MANUAL

This manual is designed to provide the customer with a means to identify the parts on his/her tractor when ordering repair parts. The illustrations may or may not represent the actual assemblies; therefore, it is not recommended to use this manual as a guide to assemble or disassemble the tractor. Some hardware and parts are drawn larger in order to more readily identify them.

Each tractor has its own model number.

The model number for your tractor can be found on the fender under the seat.

When ordering parts, always give the following information:

- Product - "TRACTOR"
- MODEL NUMBER - "YTA19K42" (96045003300)"
- Part Number
- Part Description

TABLE OF CONTENTS

SCHEMATIC	3
ELECTRICAL.....	4-5
CHASSIS	6-7
DRIVE.....	8-9
ENGINE.....	10-11
STEERING	12-13
MOWER DECK.....	14-15
MOWER LIFT.....	16
SEAT	17
DECALS.....	18

COMO UTILIZAR ESTE MANUAL

Este manual está diseñado para brindarle al comprador un medio para identificar las piezas del tractor para cuando necesite hacer el pedido de un repuesto. Las ilustraciones pueden o no representar los ensambles reales; por lo tanto, no se recomienda utilizar este manual como una guía para ensamblar o desarmar el tractor. Algunos accesorios y piezas están dibujados en tamaños más grandes para identificarlos con mayor facilidad.

Cada tractor tiene su propio número de modelo.

El número de modelo del tractor se encuentra en el guardabarros debajo del asiento.

Cuando haga el pedido de una pieza, siempre brinde la siguiente información:

- Producto: "TRACTOR"
- NÚMERO DE MODELO: "YTA19K42" (96045003300)"
- Número de pieza
- Descripción de la pieza

ÍNDICE

DIAGRAMA.....	19
DIAGRAMA ELÉCTRICO	20-21
CHASIS	22-23
TRANSMISIÓN	24-25
MOTOR	26-27
DIRECCIÓN	28-29
PLATAFORMA DE LA CORTADORA DE CÉSPED.....	30-31
ELEVACIÓN DE LA CORTADORA DE CÉSPED.....	32
ASIENTO.....	33
CALCOMANÍAS.....	34

TRACTOR - - MODEL NUMBER YTA19K42 (96045003300), PRODUCT NO. 960 45 00-33 SCHEMATIC

SCH10

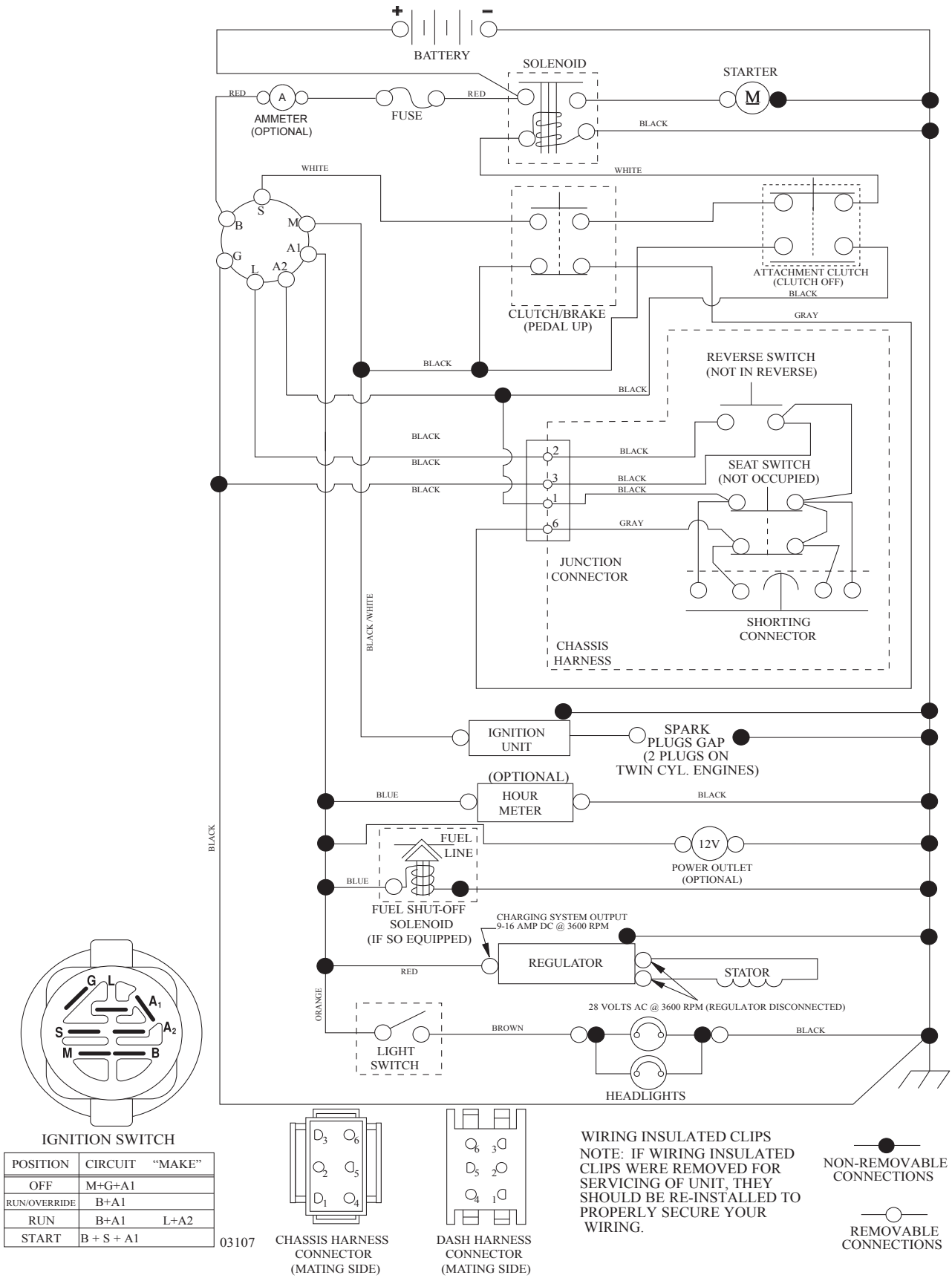

TRACTOR - - MODEL NUMBER YTA19K42 (96045003300), PRODUCT NO. 960 45 00-33
ELECTRICAL

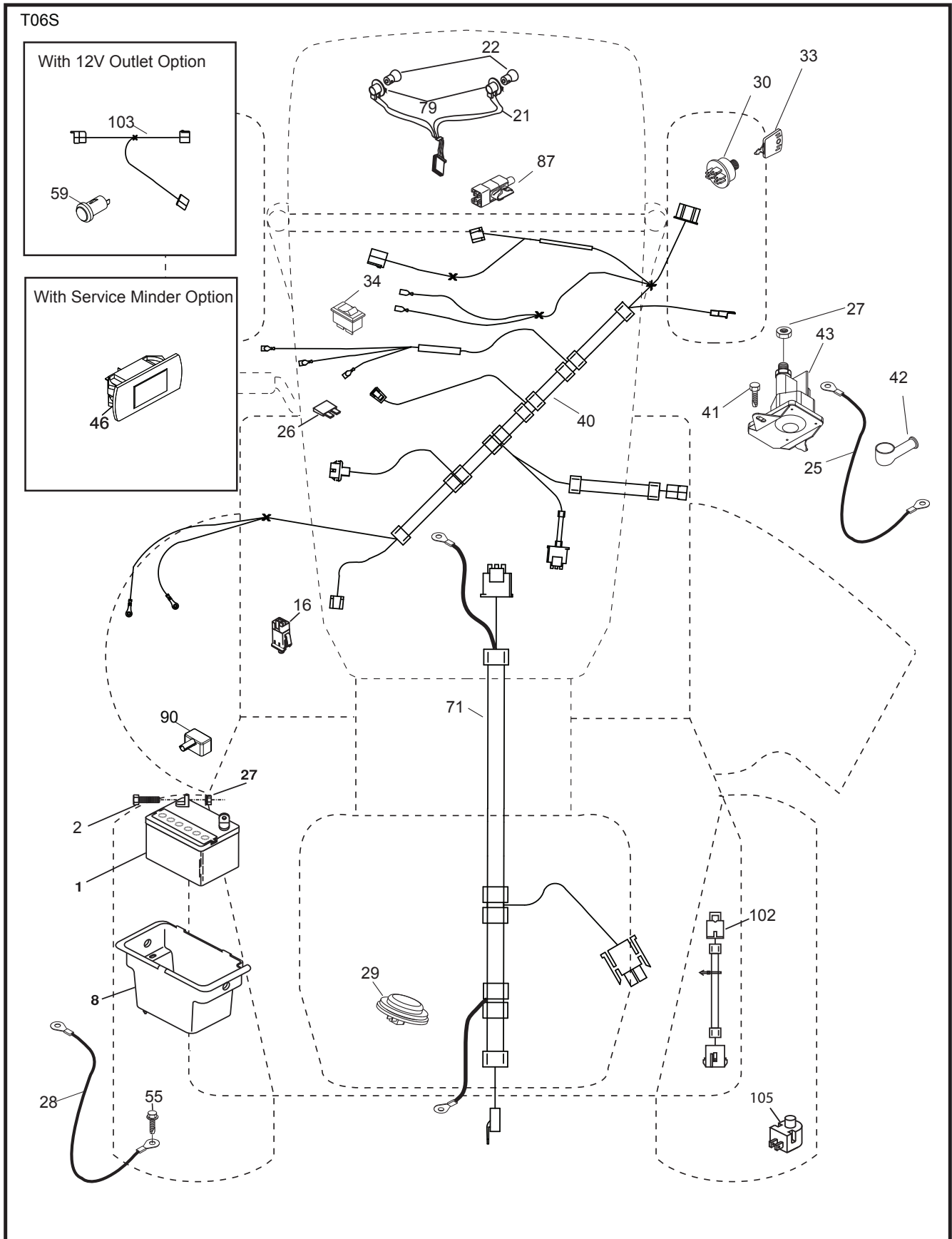

**TRACTOR - - MODEL NUMBER YTA19K42 (96045003300), PRODUCT NO. 960 45 00-33
ELECTRICAL**

KEY NO.	PART NO.	DESCRIPTION
1	532 16 34-65	Battery
2	874 76 04-12	Bolt Hex Hd 1/4-20 unc x 3/4
8	532 19 32-28	Box Battery
16	532 17 61-38	Switch Interlock
21	532 40 02-52	Harness Socket Light
22	532 00 41-52	Bulb, Light #1156
25	532 41 28-95	Cable Starter 6 Ga. BL/Red 14.5
26	532 17 51-58	Fuse
27	873 51 04-00	Nut Keps Hex 1/4-20 unc
28	532 19 88-85	Cable Ground 18" Rear Battery Blk 6 Ga.
29	532 40 15-45	Switch Seat
30	532 19 33-50	Switch Ign
33	532 41 19-33	Key/Chain
34	532 11 07-12	Switch Light/Reset
40	532 40 10-98	Harness Ign
41	817 72 04-08	Screw 1/4-20 unc x 1/2
42	532 13 15-63	Cover Terminal Red
43	532 19 25-07	Solenoid
46	532 40 17-63	Guage SRVCMNDR
55	817 06 05-12	Screw 5/16-18 x 3/4
71	532 40 04-49	Harness Ign. Chass.
79	532 17 52-42	Socket Asm. Bulb
87	532 19 78-02	Switch Interlock Clutch
90	532 43 53-95	Cover Terminal
102	532 41 97-81	Pigtail Rev. GT Vatr.
105	532 40 75-68	Switch Reverse

NOTE: All component dimensions given in U.S. inches
1 inch = 25.4 mm

**TRACTOR - - MODEL NUMBER YTA19K42 (96045003300), PRODUCT NO. 960 45 00-33
CHASSIS**

KEY NO.	PART NO.	DESCRIPTION	KEY NO.	PART NO.	DESCRIPTION
3	532 43 97-52	Applique	195	532 40 41-37	Plug Hole Dash
5	532 43 74-73	Dash	196	532 43 96-47	Console Asm. Deck Lift
14	532 44 11-77	Hood	202	532 43 97-28	Vent Side RH
15	532 43 97-33	Lens LH	203	532 43 97-27	Vent Side LH
18	532 43 77-62	Grille	204	532 43 57-14	Vent Top
25	532 44 33-85	Lens RH	205	532 43 97-30	Side Trim RH
34	532 19 61-25	Plate Engine	206	532 43 97-29	Side Trim LH
36	817 06 05-12	Screw 5/16-18 x 3/4	207	532 43 97-34	Bezel Light RH
37	532 44 12-66	Fender	208	532 43 97-35	Bezel Light LH
52	873 68 05-00	Nut Lock 5/16-18	213	874 76 05-12	Bolt 5/16-18 x 3/4
58	532 41 22-80	Drawbar Upper	214	532 19 91-45	Clip Retainer Tinner
68	817 49 05-08	Screw Thdrol 5/16-18 x 1/2	217	532 40 91-67	Rod Pivot Hood
130	532 41 63-58	Screw #10 x 0.750	218	532 19 63-95	X-Piece Hood Step
137	532 40 75-90	Bumper Hood	228	532 19 51-61	Stud Fastener
138	532 43 97-47	Cupholder	234	532 40 47-42	Bumper Hood
150	532 43 97-31	Duct Heat Hood	235	532 40 61-29	Spacer Fender
151	532 43 66-70	Bracket Pivot	236	873 93 05-00	Nut Center Lock 5/16-18
152	532 43 98-70	Shield Browning	287	817 60 04-06	Screw 1/4-20 x 3/8
159	817 00 06-12	Screw Hexwsh Thdrol 3/8-16 x 3/4	289	532 40 35-71	Plug Cruise/Phone
162	532 14 24-32	Screw Hex Wsh Hi-Lo 1/4 x 1/2	297	532 43 74-56	Insert Reflective LH
175	532 19 63-04	Crossmember	335	532 43 98-47	Cover Lower Dash RH
176	532 40 07-76	Screw 10-24 x 5/8 Wshd Qdrx	336	532 44 53-09	Cover Lower Dash LH
177	532 19 52-27	Bushing Steering	337	532 43 81-37	Clip Xmas Tree
178	532 19 97-82	Cargo Asm. Net	346	532 12 64-71	Clip Insulator 13/32
180	532 41 50-63	Chassis			
181	532 40 47-96	Bushing Mtg. Fender Crgo.			
182	532 40 68-59	Dash Lower			
183	874 52 05-20	Bolt 5/16-18 x 1-1/4			
189	817 00 05-12	Screw 5/16-18 x 3/4			
191	532 43 74-55	Insert Reflective RH			
194	873 90 05-00	Nut Lock Hex Flange 5/16-18			

NOTE: All component dimensions given in U.S. inches
1 inch = 25.4 mm

**TRACTOR - - MODEL NUMBER YTA19K42 (96045003300), PRODUCT NO. 960 45 00-33
DRIVE**

KEY NO.	PART NO.	DESCRIPTION
1	-- -- -- --	Transmission, Gentrans (415663) (Order parts from transaxle manufacturer.)
2	532 12 35-83	Key.Square .20 x .1845/.1865
22	532 42 10-63	Rod Shift
23	532 14 08-45	Knob
33	812 00 00-01	E-Ring. #5133-75
35	532 43 54-86	Rod.Brake.Parking. Lt.Tex
37	532 12 17-49	Washer.25/32 X 1 1/4 x 16 Ga.
42	532 12 48-72	Cover.Pedal.Blk.Round
49	872 11 06-14	Bolt.Rdhd.3/8-16Uncx1-3/4.Gr 5
50	532 19 43-27	Idler.Flat.910"Offset
51	873 90 06-00	Nut, Hex, Flangelock 3/8-16
52	532 19 43-26	Idler.V-Groove.910"Offset
56	532 19 72-53	Belt.Drive.100.97"
64	532 19 62-00	Shaft Asm.Pedal.Brake Control
70	532 44 65-96	Console
73	874 49 05-44	Bolt.Hex.Flghd.5/16-18.Gr.5
74	532 14 24-32	Screw.Hex.Wsh.Hi-Lo.1/4X1/2 unc
99	532 42 73-40	Rod Bypass
116	873 90 05-00	Nut, Lock Hex Flange 5/16-18 unc
125	817 00 05-12	Screw.5/16-18 x 3/4.Smgml.Tap/Bl
131	876 02 03-12	Pin Cotter 3/32/ x 3/4
143	817 49 05-08	Screw.Thdrol.5/16-18 x 1/2 Tytt
160	532 16 94-84	Retainer.Clip(M).Dia.290
161	532 10 57-09	Spring.Return.Clutch.6.75
165	532 19 62-12	Bushing.Shaft.Brake.Hand Contr
166	532 42 91-64	Nut Push .625
167	532 40 52-57	Latch.Brake.Parking
172	532 41 56-64	Strap Torque Lh/Rh
174	532 19 72-89	Nut.Push..500
175	532 41 56-77	Shaft Asm Shift
176	532 19 62-14	Arm.Clevis.Rod.Shift
178	532 19 74-56	Spring.Shift.Gt.2006
184	532 44 14-55	Handle.Parking Brake.Lttex.505
185	872 11 06-22	Bolt.Rdhd.3/8-16Unc x 2-3/4 Gr5
186	532 19 43-21	Spacer.Retainer
187	819 13 32-10	Washer.13/32 x 2 x 10 Ga.
188	532 19 43-23	Link.Clutch.Ground Drive
189	532 19 43-17	Bellcrank.Groundrive.Nstg/Nstl
190	532 19 43-18	Keeper.Bellcrank.Drive.Ground
203	819 11 11-16	Washer 11/32 x 11/16 x 16 Ga.
205	532 12 17-48	Washer.25/32 x 1-5/8 x 16Ga.
221	532 40 31-87	Retainer.Spring.Clip.Handle
232	874 78 07-16	Bolt.Fin Hex.7/16-14 x 1 Gr5
233	532 40 52-96	Washer.Serrated
295	532 42 03-06	Pin Clevis 183 Od x 1.260 Long
296	532 42 04-71	Screw Thdrol 5/16-18 x 3
297	532 42 02-23	Nut Push 1/4
298	532 41 56-94	Pin Clevis Cbl. Brk. Variator
299	532 41 56-83	Bracket Mount Idler
300	532 41 56-81	Keeper Idler Rear
301	532 41 56-80	Pulley Idler V-Groove
302	532 41 56-66	Pulley Idler Flat 2.0 Od
303	872 11 06-18	Bolt Rdhd Sgnk 3/8-16 x 2-1/4
305	532 41 56-92	Cable Brake Variator

NOTE: All component dimensions given in U.S. inches
1 inch = 25.4 mm

TRACTOR - - MODEL NUMBER YTA19K42 (96045003300), PRODUCT NO. 960 45 00-33
ENGINE

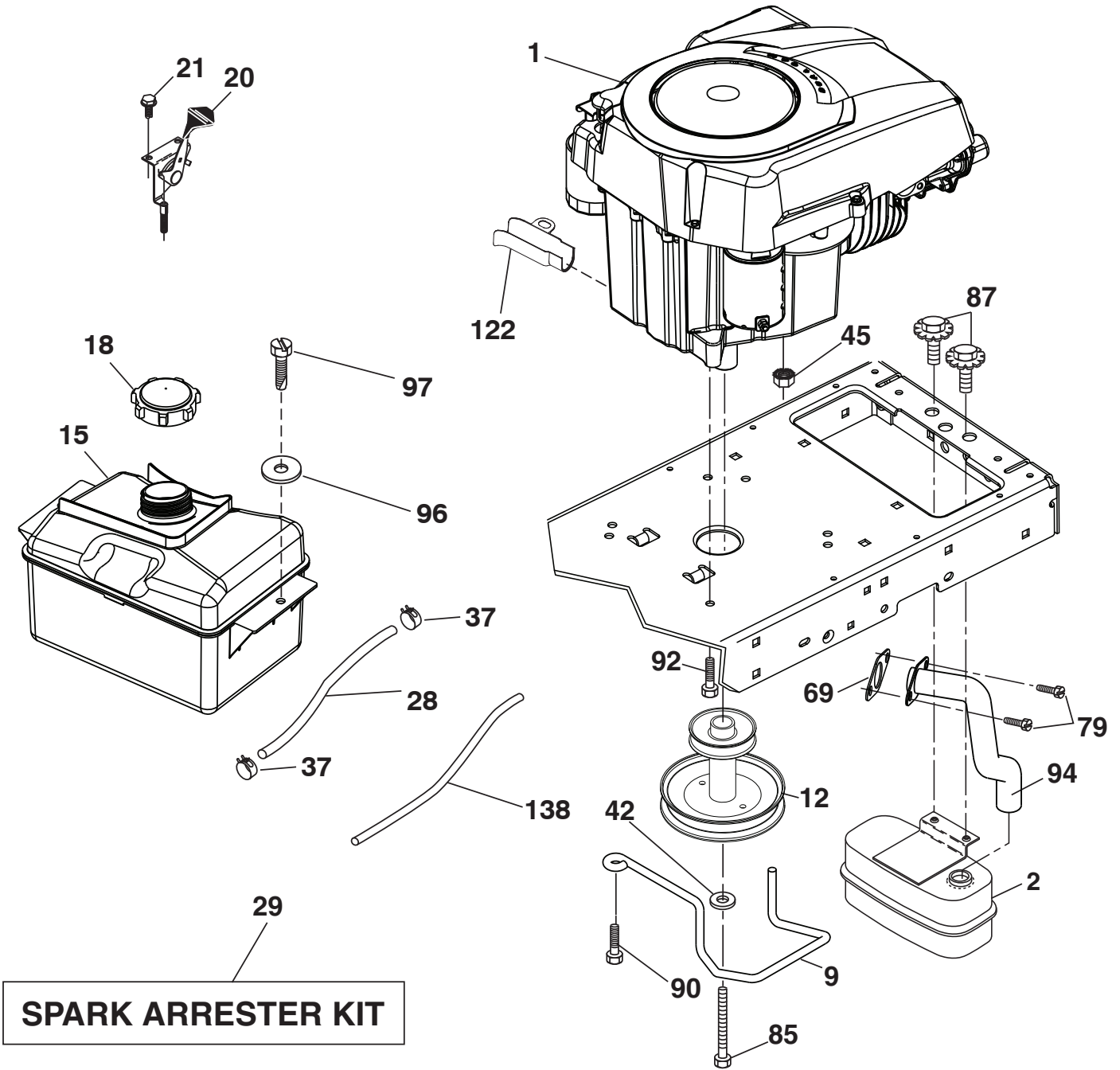

SPARK ARRESTER KIT

engine-tex_kohl_38

**TRACTOR - - MODEL NUMBER YTA19K42 (96045003300), PRODUCT NO. 960 45 00-33
ENGINE**

KEY NO.	PART NO.	DESCRIPTION
1	---	Engine Kohl Model No. SV590-3223 (438346) (Order parts from engine manufacturer.)
2	532 18 86-55	Muffler
9	532 19 43-19	Keeper Belt Engine
12	532 40 19-85	Pulley Engine
15	532 43 30-07	Tank Fuel
18	532 19 82-82	Cap Fuel
20	532 40 15-08	Control Throttle/Choke
21	532 41 63-58	Screw #10 x 0.750
28	532 40 11-37	Fuel Line
29	532 13 71-80	Spark Arrester Kit
37	532 12 34-87	Clamp Hose
42	810 04 07-00	Washer Lock 7/16
45	873 51 04-00	Nut Keps Hex 1/4-20 unc
69	532 18 59-09	Gasket
79	532 19 23-34	Screw Socket Hd 5/16-18 x .75
85	532 17 39-37	Bolt Hex 7/16-20 x 4 x Gr. 5-1.5
87	532 17 18-77	Bolt 5/16-18 unc 3/4 w/sems
90	817 00 06-16	Screw 3/8-16 x 1.0
92	817 12 06-16	Screw 3/8-16 x 1
94	532 18 86-54	Tube Exhaust
96	819 09 14-16	Washer 9/32 x 7/8 x 16 Ga.
97	817 67 04-12	Screw 1/4-20 x 3/4
122	532 42 19-22	Extension Drain Oil
138	532 41 41-19	Purge Line

NOTE: All component dimensions given in U.S. inches
1 inch = 25.4 mm

For engine service and replacement parts, call the toll free
number for your engine manufacturer listed below:
Briggs & Stratton 1-800-233-3723

TRACTOR - - MODEL NUMBER YTA19K42 (96045003300), PRODUCT NO. 960 45 00-33
STEERING

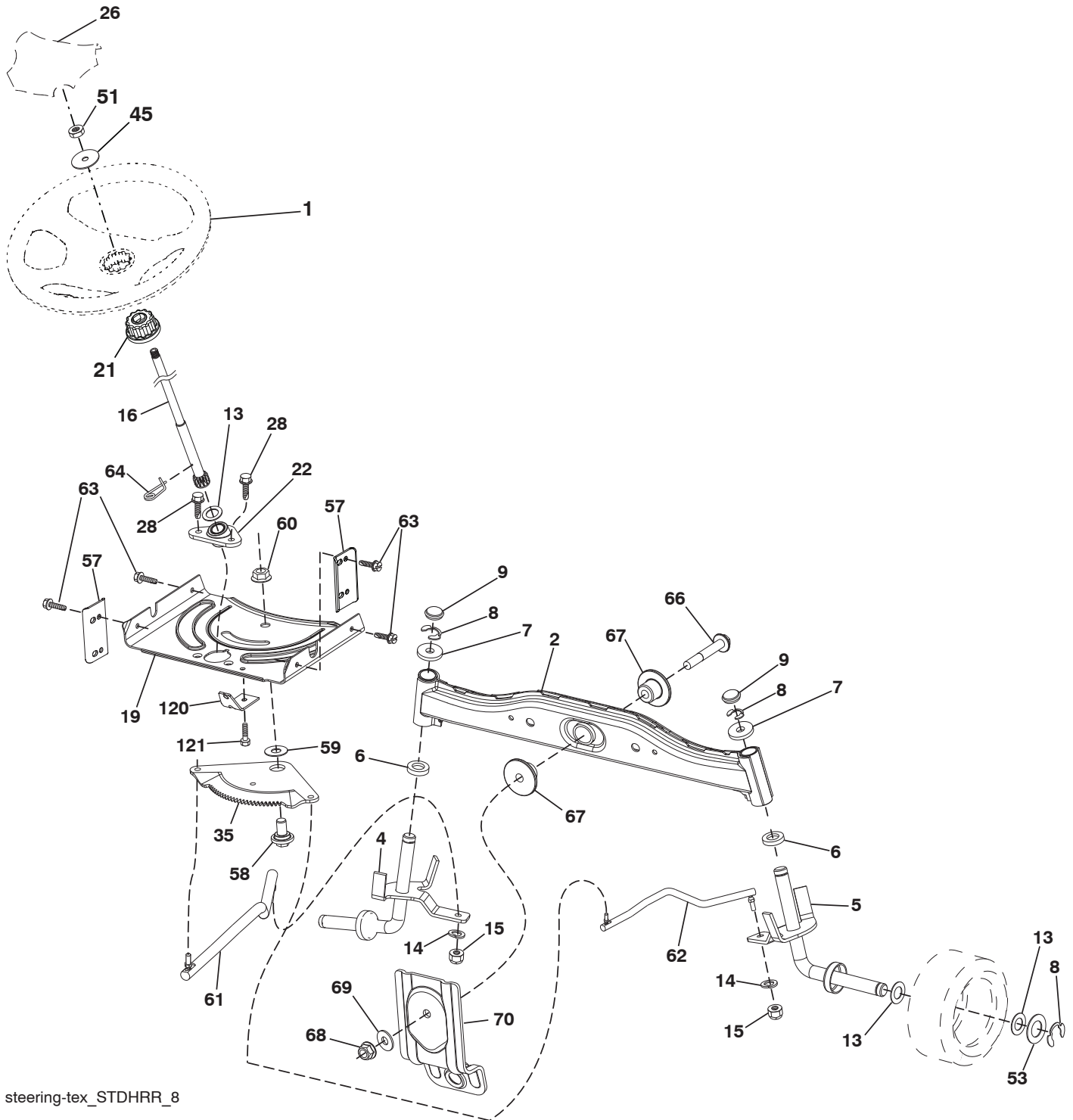

steering-tex_STDHRR_8

**TRACTOR - - MODEL NUMBER YTA19K42 (96045003300), PRODUCT NO. 960 45 00-33
STEERING**

KEY NO.	PART NO.	DESCRIPTION
1	532 43 99-97	Wheel, Steering
2	532 19 59-68	Axle Asm., Front
4	532 40 30-87	Spindle Asm., LH
5	532 40 30-88	Spindle Asm., RH
6	532 12 49-31	Washer Thrust 0.75 x 1.23
7	532 12 17-48	Washer 25/32 x 1-5/8 x 16 Ga.
8	812 00 00-29	Ring, Clip #T5304-75
9	532 12 12-32	Cap, Spindle
13	532 12 17-49	Washer 25/32 x 1-1/4 x 16 Ga.
14	810 04 06-00	Washer Lock 3/8
15	873 54 06-00	Nut, Crown Lock 3/8-24 unf
16	532 40 82-19	Shaft Steering
19	532 19 47-29	Plate Steering
21	532 18 67-37	Adapter, Wheel Steering
22	532 42 05-37	Strg. Supt. Lower
26	532 43 97-43	Insert, Wheel Steering
28	817 00 06-12	Screw 3/8-16 x 3/4
35	532 19 47-32	Gear, Sector Plate
45	819 18 38-12	Washer 11/32 x 2-3/8 x 12 Ga.
51	873 94 08-00	Nut Hex 1/2-20 unf
53	532 18 89-67	Washer Hardened .793 x 1.637 x .060
57	532 40 74-65	Bracket Upstop
58	532 19 47-47	Bolt Shoulder Sector Pivot CFM
59	532 19 47-48	Washer Thrust Sector Steering
60	873 97 10-00	Nut Flange Lock 5/8-11
61	532 19 47-40	Draglink, LH
62	532 19 47-41	Draglink, RH
63	817 00 05-12	Screw 5/16-18 x 3/4
64	532 19 98-49	Retainer Clip Spring Steering
66	871 02 07-48	Bolt Hex Fghd 7/16-14 x 3 Serr
67	532 19 47-37	Bushing PM Front Axle
68	873 90 07-00	Nut Lock Flange 7/16-14 Gr. 5
69	532 19 91-62	Washer 1.5 x .505 x .118
70	532 19 61-97	Bracket Deck Susp. Front
120	532 41 56-89	Bracket Locator
121	817 49 05-08	Screw 5/16-18 x 1/2

NOTE: All component dimensions given in U.S. inches
1 inch = 25.4 mm

**TRACTOR - - MODEL NUMBER YTA19K42 (96045003300), PRODUCT NO. 960 45 00-33
MOWER DECK**

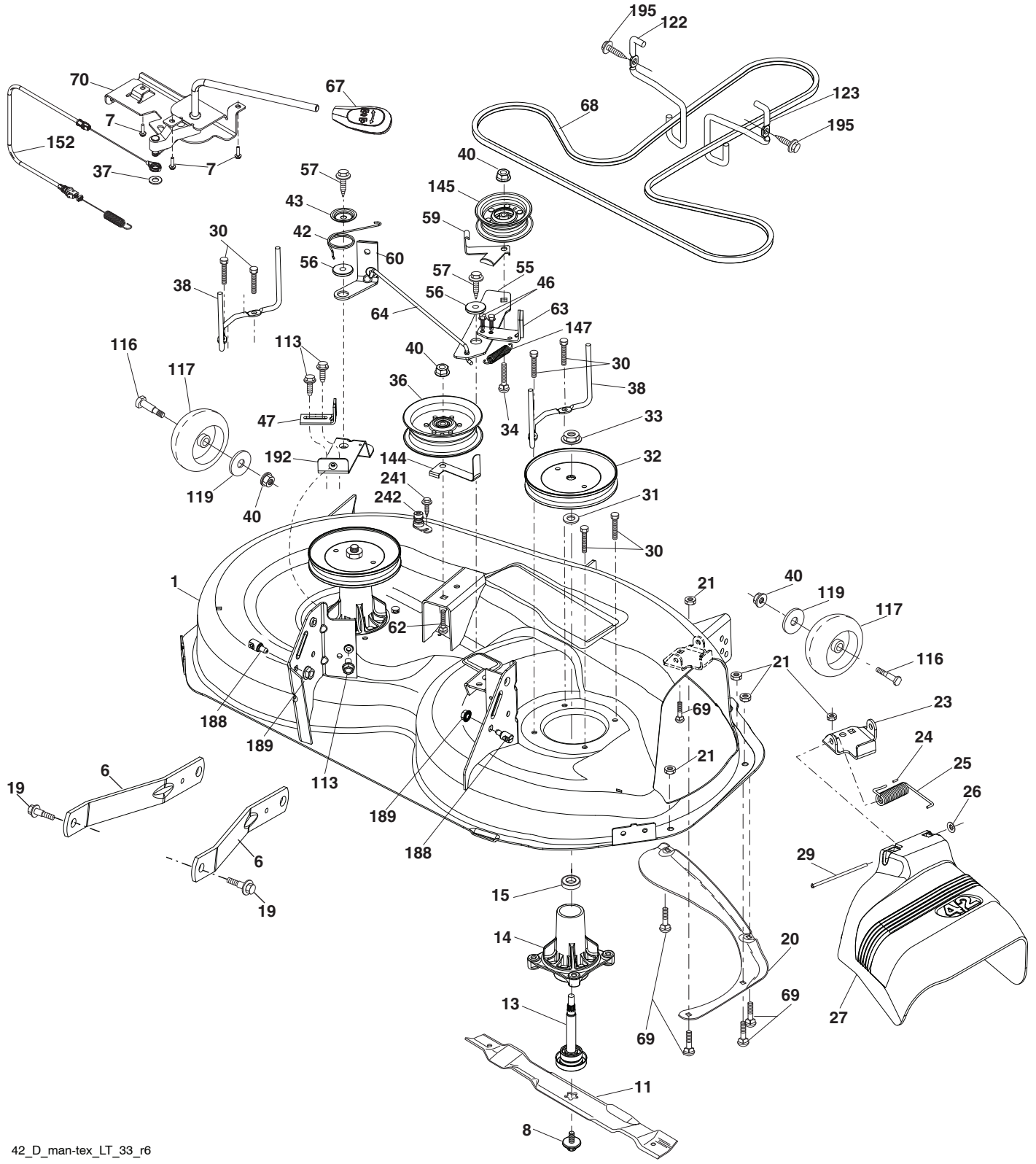

42_D_man-tex_LT_33_r6

**TRACTOR - - MODEL NUMBER YTA19K42 (96045003300), PRODUCT NO. 960 45 00-33
MOWER DECK**

KEY NO.	PART NO.	DESCRIPTION	KEY NO.	PART NO.	DESCRIPTION
1	532 43 98-17	Mower Housing	64	532 19 99-18	Linkage Brake
6	532 19 51-86	Arm Suspension	67	532 40 30-12	Handle, Clutch Cable
7	532 41 63-58	Screw #10 x 0.750 BOS Thread	68	532 42 96-36	V-Belt
8	532 19 30-03	Bolt/Washer Asm 7/16-20 unf	69	872 14 05-05	Bolt Rdhd Sqnk 5/16-18 x 5/8
11	532 13 89-71	Blade, 42" Hi-Lift (For bagging or discharge)	70	532 19 99-72	Clutch Asm. Manual
13	532 19 28-72	Shaft Assembly, Mandrel	113	817 00 05-10	Screw 5/16-18
14	532 18 72-81	Housing, Mandrel	116	532 12 48-42	Bolt Shoulder
15	532 11 04-85	Bearing, Ball, Mandrel	117	532 18 86-06	Wheel Gage
19	532 19 65-39	Bolt, Shoulder	119	819 12 14-14	Washer 3/8 x 7/8 x 14 Ga.
20	532 15 97-70	Baffle, Vortex	122	532 19 72-58	Keeper Belt Eng. LH
21	873 68 05-00	Nut, Crownlock 5/16-18 unc	123	532 19 72-59	Keeper Belt Eng. RH
23	532 19 25-57	Bracket, Deflector	144	532 19 92-04	Keeper Belt
24	532 10 53-04	Cap, Sleeve	145	532 19 31-97	Pulley Idler Primary
25	532 19 70-26	Spring, Torsion, Deflector	147	532 40 19-71	Spring Return
26	532 11 04-52	Nut, Push	152	532 43 51-10	Cable Clutch Manual w/Spr.
27	532 40 30-04	Shield, Deflector	188	532 19 51-61	Stud Fastener
29	532 13 14-91	Rod, Hinge	189	873 90 05-00	Nut Lock Hex Flange
30	532 17 39-84	Screw Thdrol Rolling Wsh Hd	192	532 19 72-60	Bracket Brake Stand LH
31	532 18 76-90	Washer, Spacer	195	817 00 06-12	Screw Hexwsh Thdr 3/8-16 x 3/4
32	532 19 74-73	Pulley, Mandrel	241	532 15 29-27	Screw #10-3 2.5.3/8
33	532 40 02-34	Nut, Toplock, Flanged	242	532 41 55-98	Port Washout
34	872 11 06-12	Bolt Carr Sh. 3/8-16 x 1-1/2 Gr. 5	--	532 19 28-70	Mandrel Assembly (Includes housing, shaft assembly, and bearing only - pulley/nut/washer and blade bolt/washers not included)
36	532 19 73-79	Pulley, Idler 4.50 RAW	--	532 43 29-37	Replacement Mower, Complete
37	819 13 13-16	Washer 13/32 x 13/16 x 16 Ga.			
38	532 43 25-20	Keeper Belt Mandrel			
40	873 90 06-00	Nut, Lock Flg. 3/8-16 unc			
42	532 19 84-10	Spring Torsion Brake			
43	532 19 72-56	Spring Torsion Retainer			
46	532 13 77-29	Screw Thd Roll 1/4-20 x 5/8			
47	532 19 72-50	Bracket Clutch Cable			
55	532 43 71-10	Arm, Idler			
56	532 19 90-92	Spacer, Retainer			
57	817 00 06-16	Screw Hexwsh Thd 3/8-16 x 1			
59	532 14 10-43	Guard, Tuv Idler (94)			
60	532 19 72-61	Arm Brake Mower			
62	872 11 06-16	Bolt Rdhd Sqnk 3/8-16 unc x 2			
63	532 19 94-77	Arm Brake Mower			

NOTE: All component dimensions given in U.S. inches
1 inch = 25.4 mm

**TRACTOR - - MODEL NUMBER YTA19K42 (96045003300), PRODUCT NO. 960 45 00-33
MOWER LIFT**

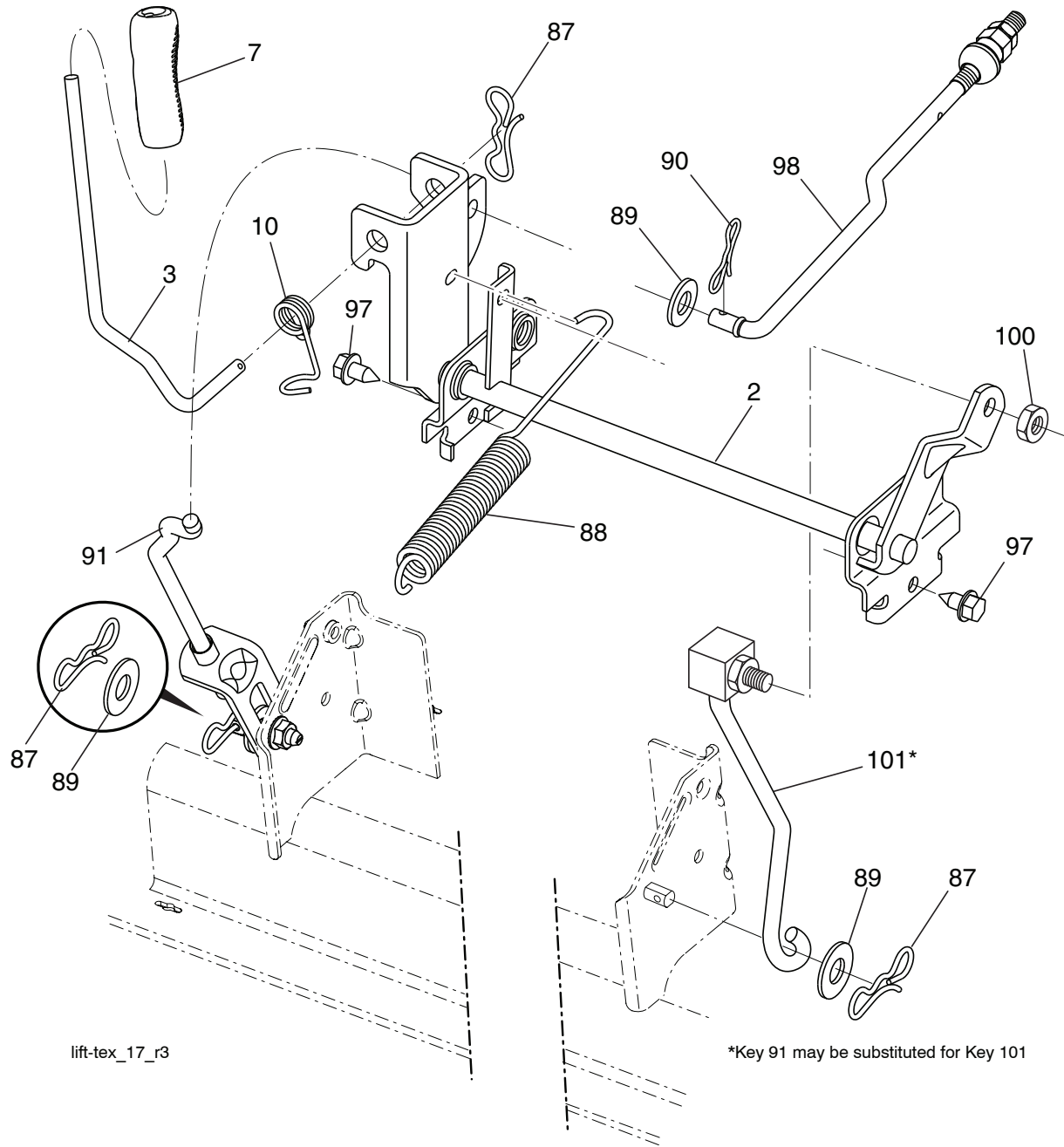

KEY NO.	PART NO.	DESCRIPTION
2	532 42 20-27	Shaft Asm., Cross Lift
3	532 19 52-31	Lever Asm., Lift RH
7	532 41 15-55	Grip, Lever
10	532 19 63-14	Spring Torsion
87	532 19 42-09	Pin Cotter 7/16 Bow Tie Lock
88	532 41 07-10	Spring Lift Assist
89	819 19 19-12	Washer Clear Zinc
90	532 19 42-08	Pin Cotter 5/16 Bow Tie Lock

KEY NO.	PART NO.	DESCRIPTION
91	532 19 51-81	Link Lift Susp Mower Rear
97	817 00 06-12	Screw 3/8-16 x .75 Smgml Tap/R.Z
98	532 19 52-70	Link Lift Susp. Front Mower
100	873 93 06-00	Nut Centerlock 3/8 -16 unc
101	532 40 70-03	Link Asm. Lift Fixed

NOTE: All component dimensions given in U.S. inches
1 inch = 25.4 mm

TRACTOR - - MODEL NUMBER YTA19K42 (96045003300), PRODUCT NO. 960 45 00-33 SEAT

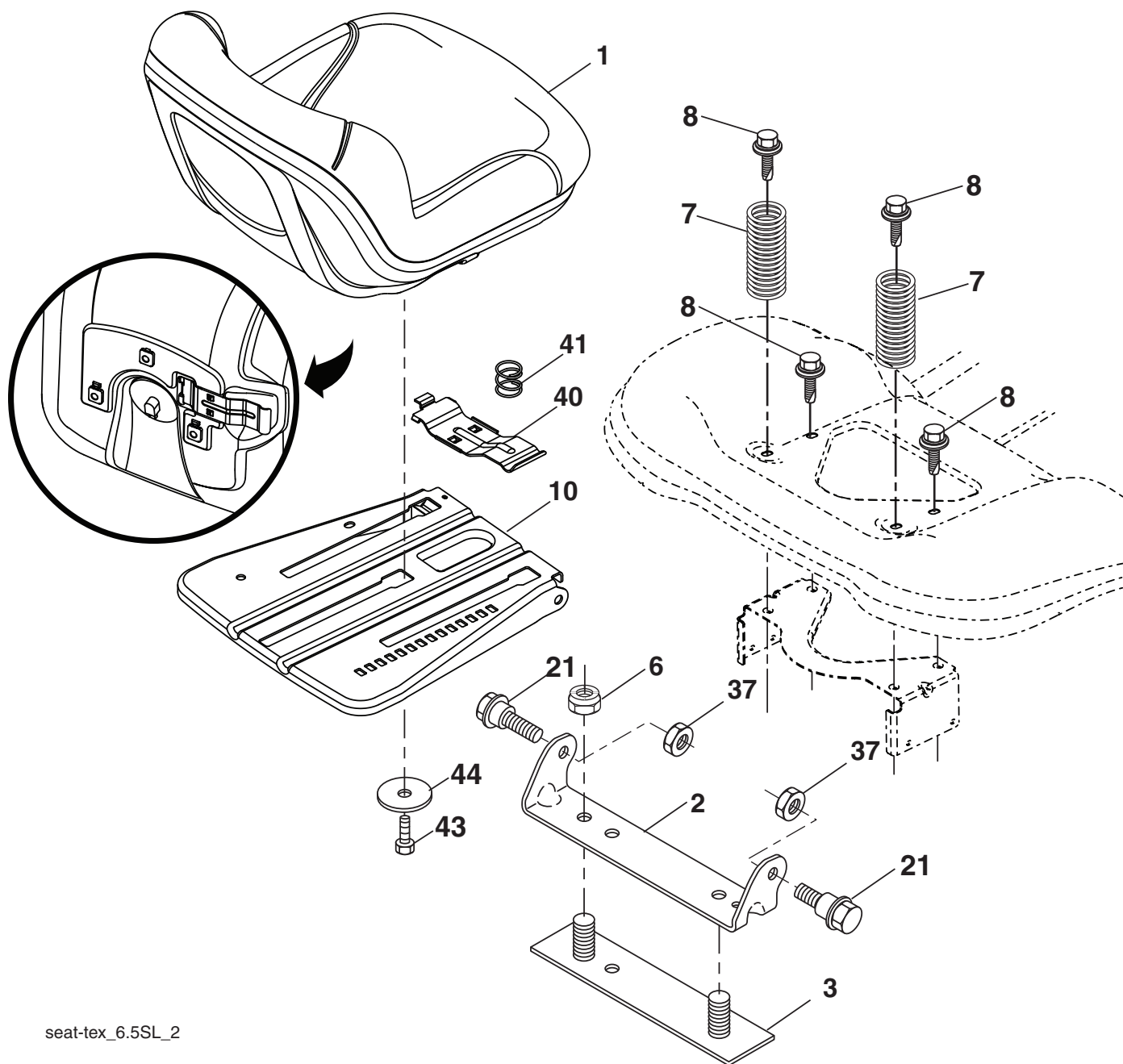

seat-tex_6.5SL_2

KEY NO.	PART NO.	DESCRIPTION
1	532 43 98-19	Seat
2	532 18 01-66	Bracket Pivot Fender
3	532 14 06-75	Strap, Asm Fender
6	873 80 06-00	Nut, Lock w/Ins. 3/8-16 unc
7	532 12 41-81	Spring, Seat Cprsn
8	532 17 18-77	Bolt 5/16-18 unc x 3/4 w/Sems
10	532 19 69-77	Pan, Seat
21	532 17 18-52	Bolt, Shoulder 5/16-18

KEY NO.	PART NO.	DESCRIPTION
37	873 80 05-00	Nut, Lock 5/16-18 unc
40	532 19 76-61	Handle Slide
41	532 19 82-00	Spring Latch
43	874 76 06-12	Bolt 3/8-16 unc x 3/4
44	819 13 38-12	Washer 13/32 x 2 3/8 x 12 Ga.

NOTE: All component dimensions given in U.S. inches
1 inch = 25.4 mm

**TRACTOR - - MODEL NUMBER YTA19K42 (96045003300), PRODUCT NO. 960 45 00-33
DECALS**

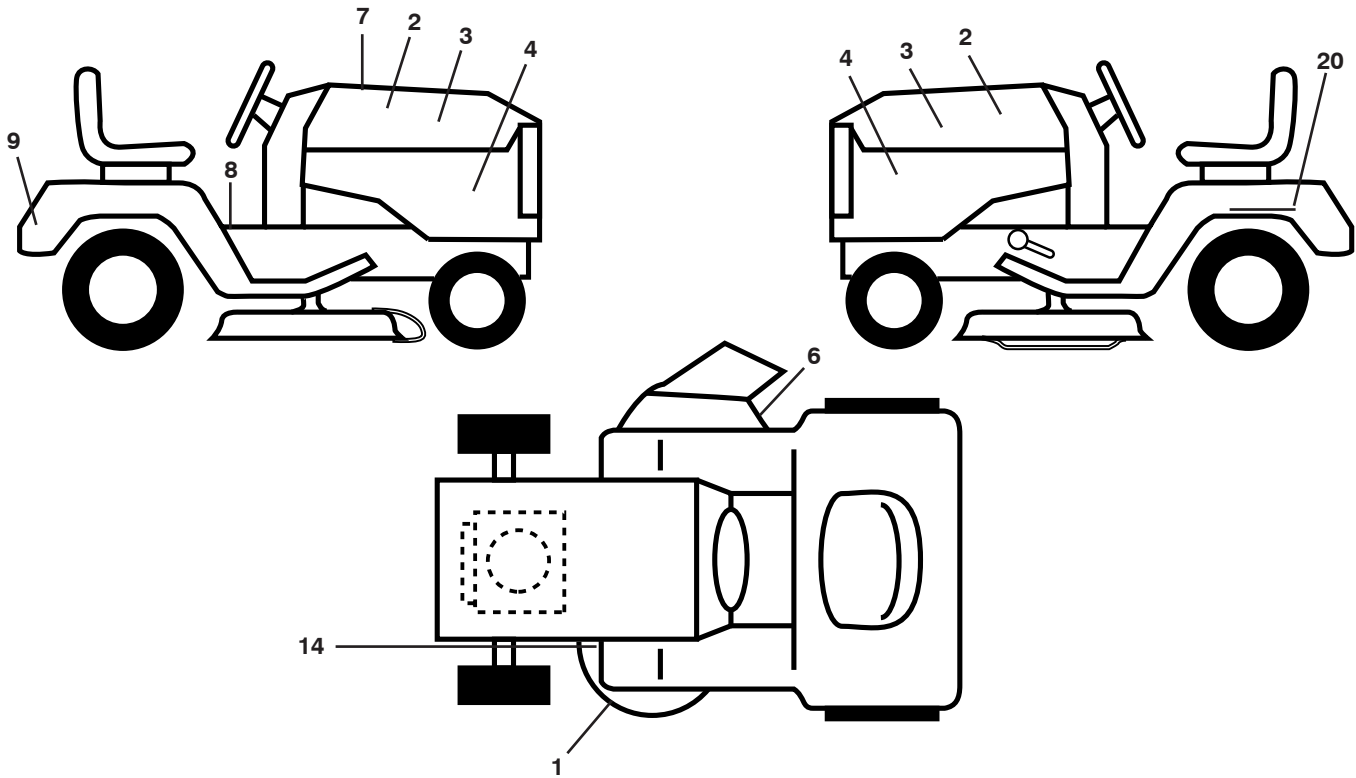

KEY NO.	PART NO.	DESCRIPTION
1	532 16 03-96	Decal Mower V Belt
2	532 42 38-29	Decal Customer Resp.
3	532 42 91-96	Decal Hood
4	532 44 57-58	Decal Side Panel Logo
6	532 17 05-63	Decal Warning, Keep Hand Away
7	532 44 54-95	Decal Replacement Parts
8	532 41 16-57	Decal Fender Warn S/F
9	532 19 15-54	Decal Fender Logo

KEY NO.	PART NO.	DESCRIPTION
14	532 16 03-96	Decal V-Belt Schematic
20	532 14 50-05	Decal Bat Dan/Psn
--	532 16 69-60	Decal Bypass
--	532 43 96-81	Pad Footrest LH
--	532 43 96-66	Pad Footrest RH
--	532 44 57-32	Manual Operator's (English/Spanish)
--	532 44 57-33	Manual Parts (English/Spanish)

WHEELS AND TIRES

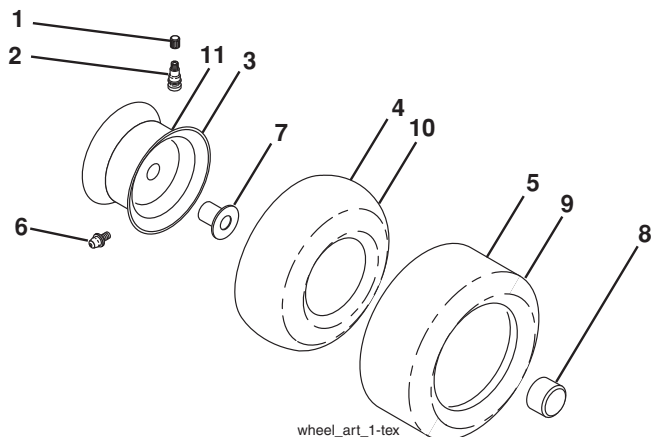

KEY NO.	PART NO.	DESCRIPTION
1	532 05 91-92	Cap Valve Tire
2	532 06 51-39	Stem Valve
3	532 13 83-36	Rim Asm 6" Front
4	532 05 99-04	Tube Front (Service Item Only)
5	532 10 62-22	Tire F T 15 x 6 0 - 6
6	532 12 49-57	Fitting Grease (Front Wheel Only)
7	532 12 49-59	Bearing Flange (Front Wheel Only)
8	532 17 50-39	Cap Axle
9	532 42 05-31	Tire R T 18 x 9.5-8C Turf Saver LT
10	532 12 49-26	Tube Rear (Service Item Only)
11	532 13 83-37	Rim Asm 8" Rear Service
--	532 14 43-34	Sealant, Tire (Not Shown)

NOTE: All component dimensions given in U.S. inches
1 inch = 25.4 mm