

917.240460 (YTH20K46)

ILLUSTRATED PARTS LIST

Gasoline containing up to 10% ethanol (E10) is acceptable for use in this machine.
The use of any gasoline exceeding 10% ethanol (E10) will void the product warranty.

TRACTOR - - MODEL NUMBER 917.240460, PRODUCT NO. YTH20K46

SCHEMATIC

SCH10

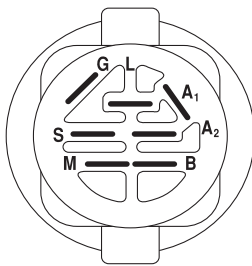
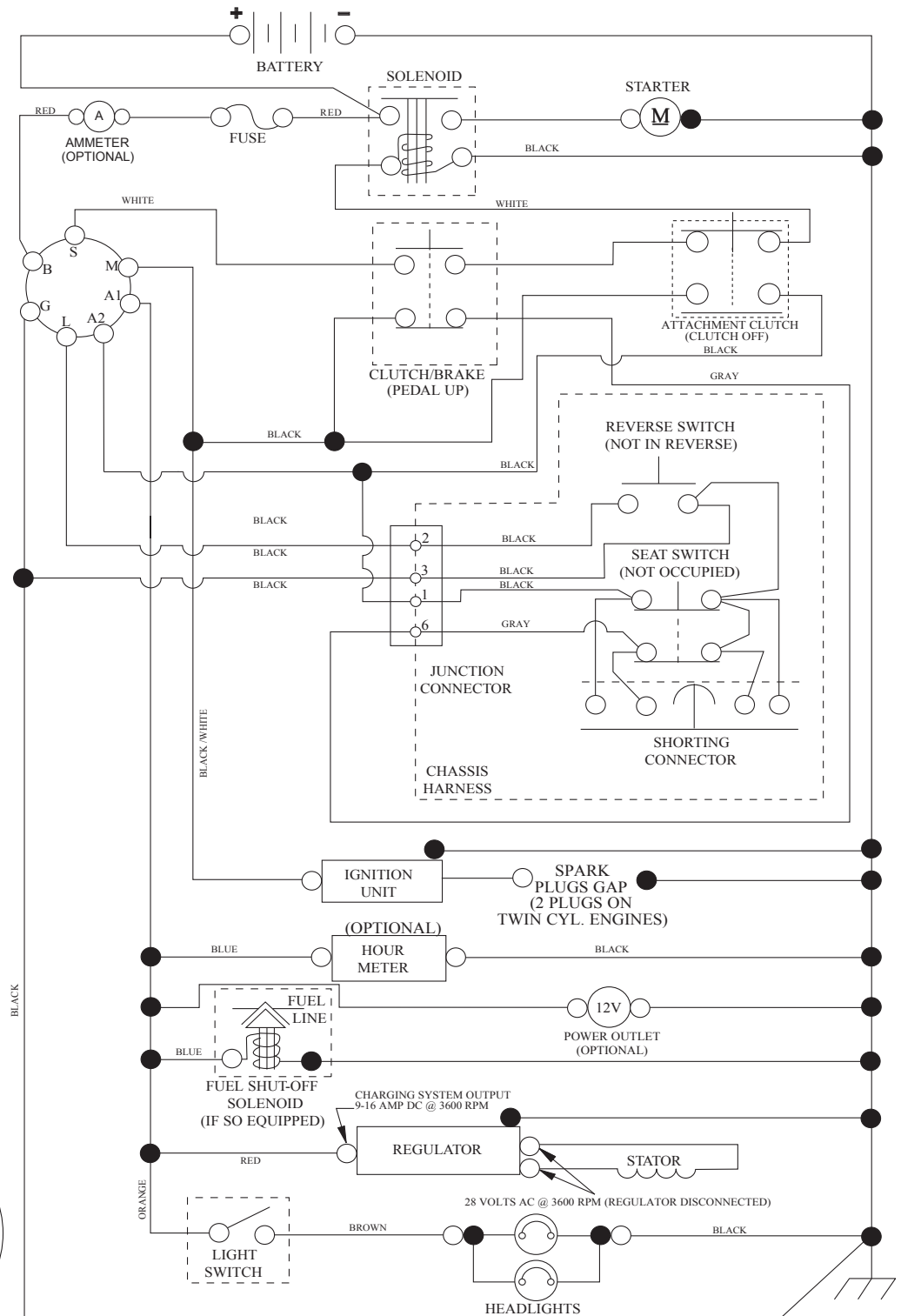

IGNITION SWITCH

POSITION	CIRCUIT	"MAKE"
OFF	M+G+A1	
RUN/OVERRIDE	B+A1	
RUN	B+A1	L+A2
START	B + S + A1	

03107

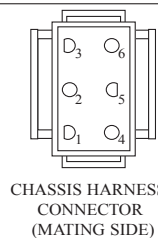

CHASSIS HARNESS CONNECTOR (MATING SIDE)

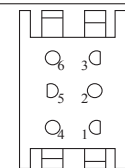

DASH HARNESS CONNECTOR (MATING SIDE)

WIRING INSULATED CLIPS
NOTE: IF WIRING INSULATED CLIPS WERE REMOVED FOR SERVICING OF UNIT, THEY SHOULD BE RE-INSTALLED TO PROPERLY SECURE YOUR WIRING.

●
NON-REMOVABLE CONNECTIONS

○
REMOVABLE CONNECTIONS

TRACTOR -- MODEL NUMBER 917.240460, PRODUCT NO. YTH20K46 ELECTRICAL

T06S

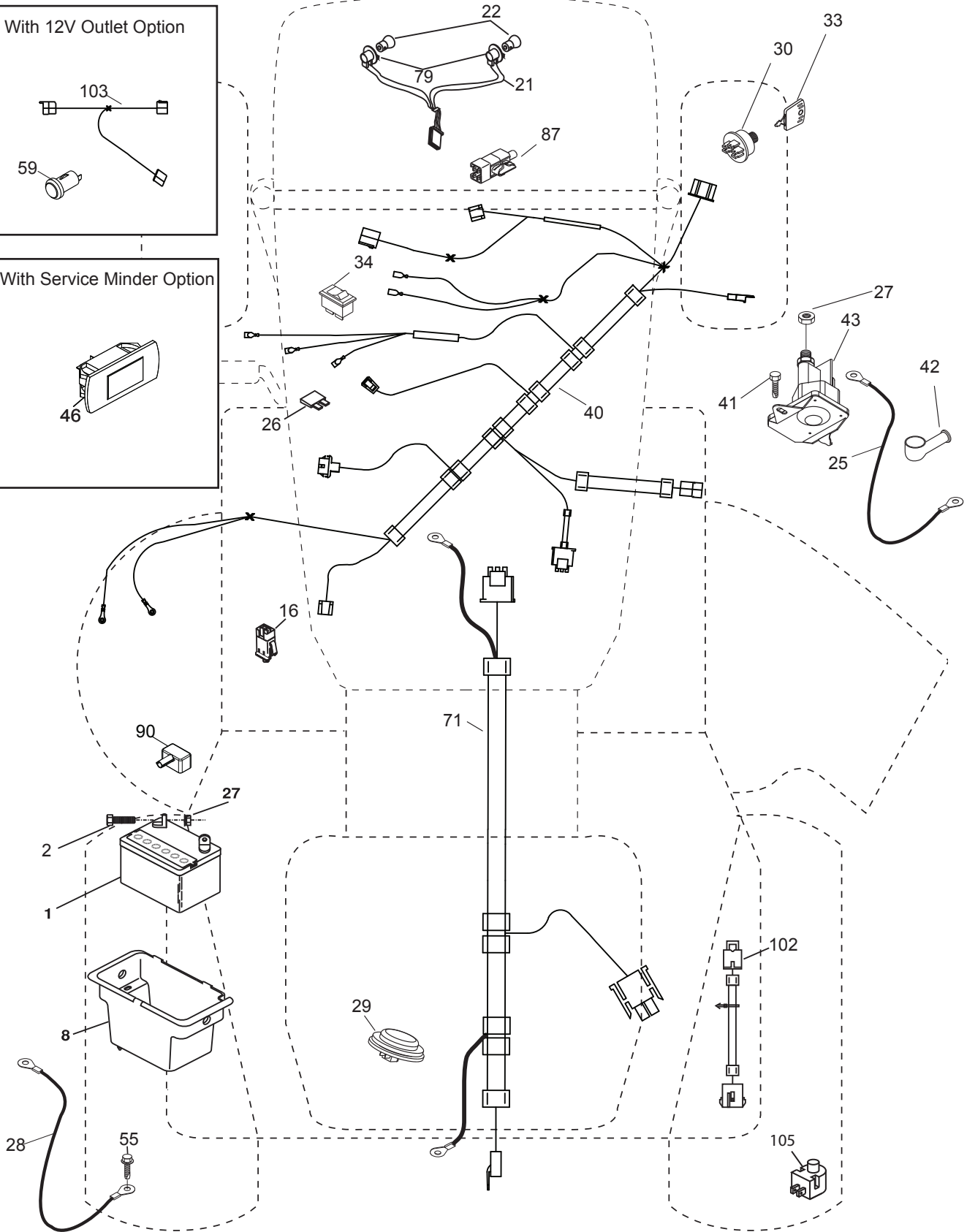
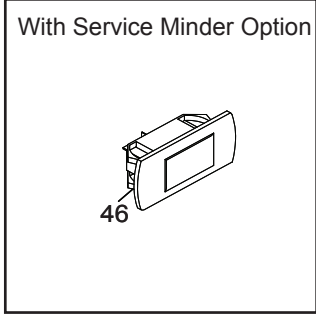
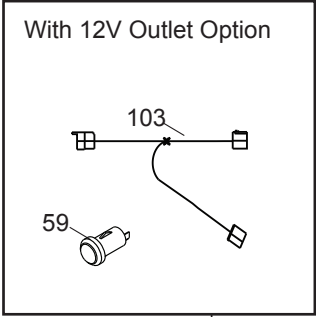

**TRACTOR - - MODEL NUMBER 917.240460, PRODUCT NO. YTH20K46
ELECTRICAL**

KEY NO.	PART NO.	DESCRIPTION
1	532 16 34-65	Battery
2	874 76 04-12	Bolt Hex Head 1/4-20 x 3/4
8	532 19 32-28	Box Battery
16	532 17 61-38	Switch Interlock Push-In
21	532 40 02-52	Harness Socket Light w/4152J
22	532 00 41-52	Bulb Light
25	532 41 28-95	Cable Starter
26	532 17 51-58	Fuse
27	873 51 04-00	Nut Keps Hex 1/4-20 unc
28	532 19 88-85	Cable, Ground
29	532 40 15-45	Switch, Seat
30	532 19 33-50	Switch, Ign
33	532 41 19-33	Key / Chain
34	532 11 07-12	Switch Light / Reset
40	532 40 04-49	Harness Ign.
41	817 72 04-08	Screw Thd Cut 1/4-20 x 1/2
42	532 13 15-63	Cover, Terminal
43	532 19 25-07	Solenoid
46	532 40 17-63	Gauge Hourmeter
55	817 06 05-12	Screw Thdrol 5/16-18 x 3/4 TYTT
71	532 40 10-98	Harness Ign. Dash
79	532 17 52-42	Socket Asm. Bulb Twistlock
87	532 19 78-02	Switch Interlock Clutch Cable
90	532 43 53-95	Cover Terminal
102	532 40 44-54	Harness Pigtail
105	532 40 75-68	Switch Reverse TT GT

NOTE: All component dimensions given in U.S. inches
1 inch = 25.4 mm

TRACTOR - - MODEL NUMBER 917.240460, PRODUCT NO. YTH20K46

CHASSIS

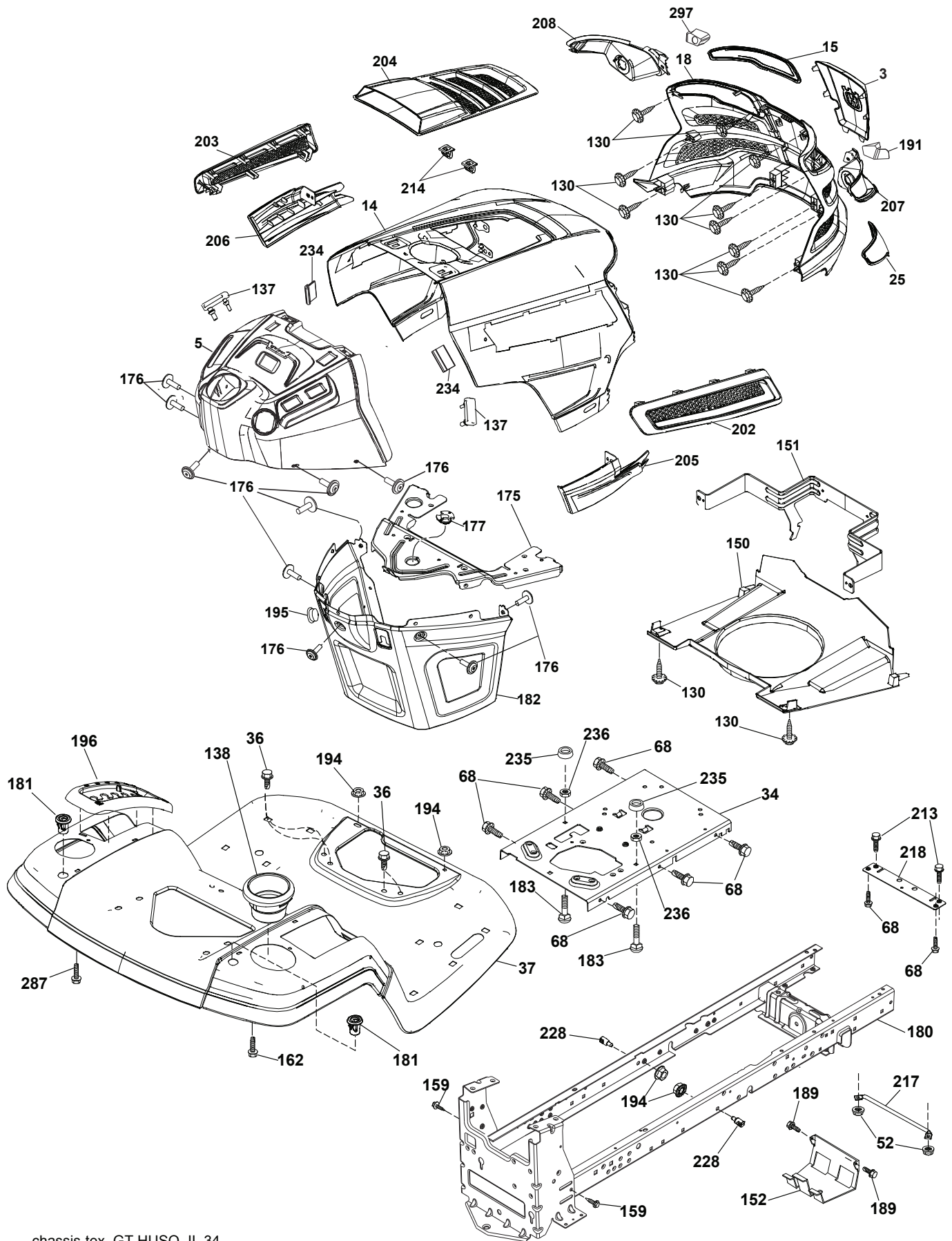

**TRACTOR - - MODEL NUMBER 917.240460, PRODUCT NO. YTH20K46
CHASSIS**

KEY NO.	PART NO.	DESCRIPTION
3	532 43 97-52	Logo Crown
5	532 43 74-73	Dash
14	532 44 11-77	Hood
15	532 43 97-32	Lens LH
18	532 43 77-62	Grille/Lens Asm.
25	532 43 97-33	Lens RH
34	532 19 61-25	Plate Engine
36	817 06 05-12	Screw 5/16-18 x 3/4
37	532 44 12-06	Fender
52	873 68 05-00	Nut Lock 5/16-18
68	817 49 05-08	Screw Thdrol 5/16-18 x 1/2
130	532 41 63-58	Screw #10 x 0.750 BOS Thread
137	532 40 75-90	Bumper Dash
138	532 43 97-47	Cupholder
150	532 43 97-31	Air Duct
151	532 43 66-70	Bracket Pivot Hood
152	532 19 95-35	Shield Browning
159	817 00 06-12	Screw Hexwsh Thdr 3/8-16 x 3/4
162	532 14 24-32	Screw
175	532 19 63-04	Crossmember
176	532 40 07-76	Screw 10-24 x 5/8
177	532 19 52-27	Bushing Steering
180	532 19 54-57	Chassis
181	532 43 97-46	Bushing Mtg. Fender Crgo
182	532 40 68-59	Dash Lower
183	874 52 05-20	Bolt 5/16-18 x 1-1/4 Full Thread
189	817 00 05-12	Screw 5/16-18 x 3/4
191	532 43 74-55	Insert Reflective RH
194	873 90 05-00	Nut Lock Hex Flange 5/16-18
195	532 40 41-37	Plug Hole Dash Lower
196	532 43 96-47	Console Asm. Deck Lift
202	532 43 97-28	Vent Side Hood RH
203	532 43 97-27	Vent Side Hood LH
204	532 43 57-14	Vent Top Hood
205	532 43 97-30	Skirt Hood Side RH
206	532 43 97-29	Skirt Hood Side LH
207	532 43 97-34	Bezel RH
208	532 43 97-35	Bezel LH
213	874 76 05-12	Bolt 5/16-18 x 3/4
214	532 19 91-45	Clip Retainer Tinner
217	532 40 91-67	Rod Pivot
218	532 19 63-95	X-Piece Hood Stop
228	532 19 51-61	Stud Fastner
234	532 40 47-42	Bumper Hood
235	532 40 61-29	Spacer Fender
236	873 93 05-00	Nut Lock 5/16-18 unc
287	817 60 04-06	Screw Hex Washhead 1/4-20 x 3/8
297	532 43 74-56	Insert Reflective LH

NOTE: All component dimensions given in U.S. inches
1 inch = 25.4 mm

TRACTOR - - MODEL NUMBER 917.240460, PRODUCT NO. YTH20K46 DRIVE

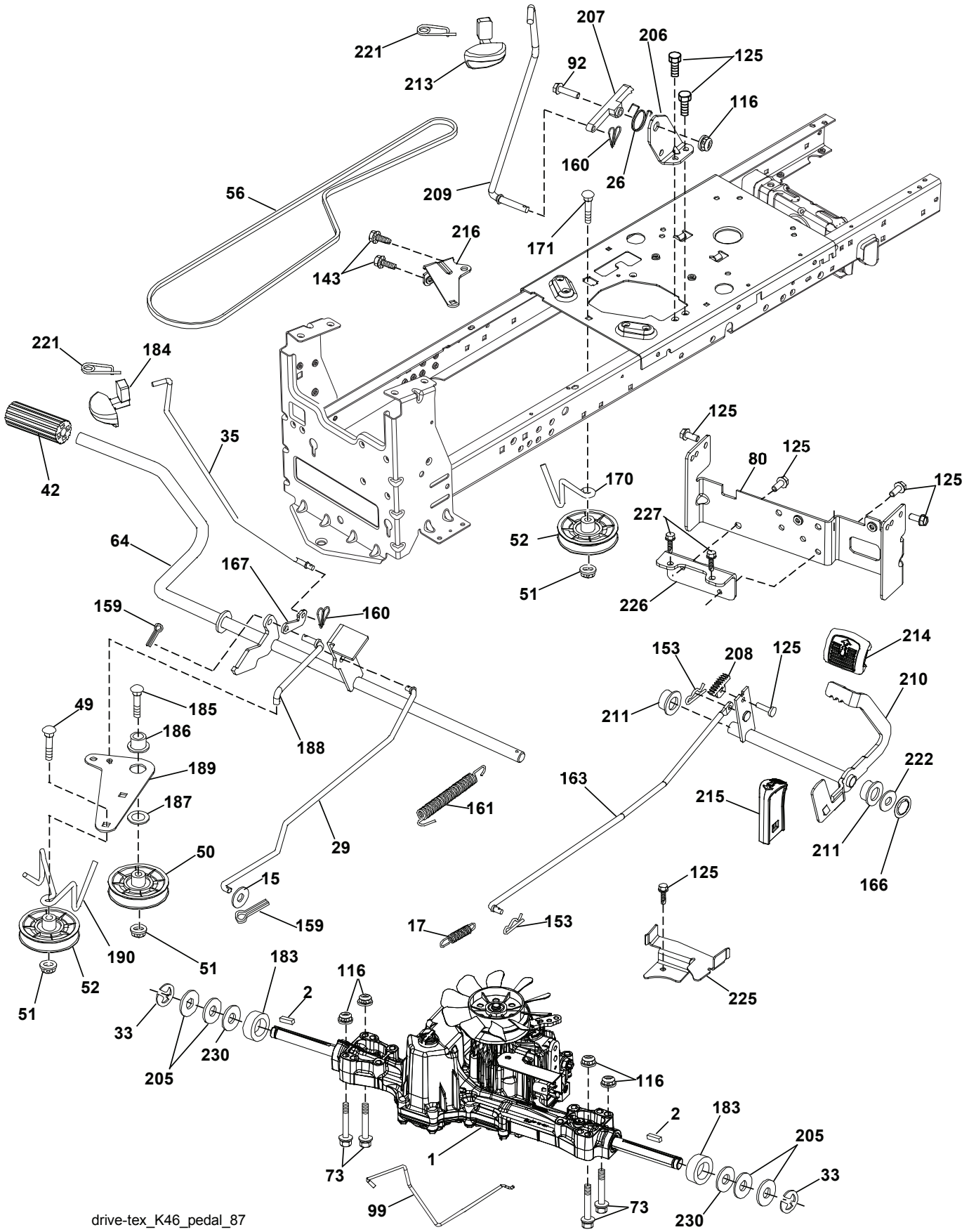

drive-tex_K46_pedal_87

TRACTOR - - MODEL NUMBER 917.240460, PRODUCT NO. YTH20K46

DRIVE

KEY NO.	PART NO.	DESCRIPTION	KEY NO.	PART NO.	DESCRIPTION
1	532 42 61-20	Transaxle, TUFFTORQ K46 BT (See Transaxle breakdown)	171	872 11 06-16	Bolt Rd Hd 3/8-16 x 2
2	532 12 35-83	Key	183	532 13 70-57	Spacer Axle
15	819 13 13-16	Washer 13/32 x 13/16 x 16 Ga.	184	532 44 14-55	Handle Parking Brake
17	532 41 36-78	Spring, Brake	185	872 11 06-22	Bolt Rdhd 3/8-16 unc x 2-3/4 Gr. 5
26	532 19 96-79	Spring Return Cruise	186	532 19 43-21	Spacer Retainer
29	532 40 38-06	Rod, Brake	187	819 13 32-10	Washer
33	812 00 00-01	Ring E	188	532 19 43-23	Link Clutch Ground Drive
35	532 43 54-86	Rod, Brake, Park	189	532 19 43-17	Bellcrank Ground Drive
42	532 12 48-72	Cover, Foot Pedal	190	532 19 43-18	Keeper Bellcrank Ground Drive
49	872 11 06-14	Bolt	205	532 12 17-48	Washer
50	532 19 43-27	Pulley Idler Flat	206	532 19 78-67	Bracket Mount Latch Cruise
51	873 90 06-00	Lock Nut 3/8-16	207	532 19 78-68	Latch Control Cruise
52	532 19 43-26	Idler V-Groove 910" Offset	208	532 19 78-69	Gear Sector Control Cruise
56	532 13 09-69	V-Belt, Drive	209	532 19 95-92	Rod Control Cruise
64	532 19 78-65	Shaft Asm. Pedal Brake Control	210	532 40 09-80	Rocker Asm. Pedal Control
73	874 49 05-40	Bolt Hex Flghd 5/16-18 x 2-1/2	211	532 12 01-83	Bearing Nylon
80	532 44 06-19	Bracket Strap Torque	213	532 40 31-19	Knob Control Cruise
92	874 76 05-20	Bolt Fin Hex 5/16-18 unc x 1.25	214	532 42 12-63	Pedal Forward
99	532 41 57-42	Rod Spring Bypass	215	532 40 17-23	Pedal Reverse
116	873 90 05-00	Nut Lock Hex Flange 5/16-18	216	532 19 61-31	Bracket Pulley Idler
125	817 00 05-12	Screw 5/16-18 x 3/4	221	532 40 31-87	Retainer Spring Clip Handle
143	817 49 05-08	Screw 5/16-18 x 1/2	222	879 21 20-10	Washer 21/32 x 1-1/4 10 Ga.
153	532 12 47-88	Retainer Spring	225	532 40 33-19	Keeper Belt Trans.
159	876 02 04-12	Pin Cotter 1/8 x 3/4	226	532 40 15-64	Bracket Mount Torque
160	532 16 94-84	Retainer Clip	227	817 49 05-12	Screw Thdrol 5/16-18 x 3/4
161	532 10 57-09	Spring, Return, Clutch	230	532 18 89-67	Washer Hardened
163	532 40 10-34	Rod Pedal Control	--	532 43 18-83	Kit Bumper
166	532 42 91-64	Nut Push			
167	532 40 52-57	Latch Brake Parking			
170	532 19 43-22	Keeper Belt Centerspan			

NOTE: All component dimensions given in U.S. inches
1 inch = 25.4 mm

**TRACTOR - - MODEL NUMBER 917.240460, PRODUCT NO. YTH20K46
ENGINE**

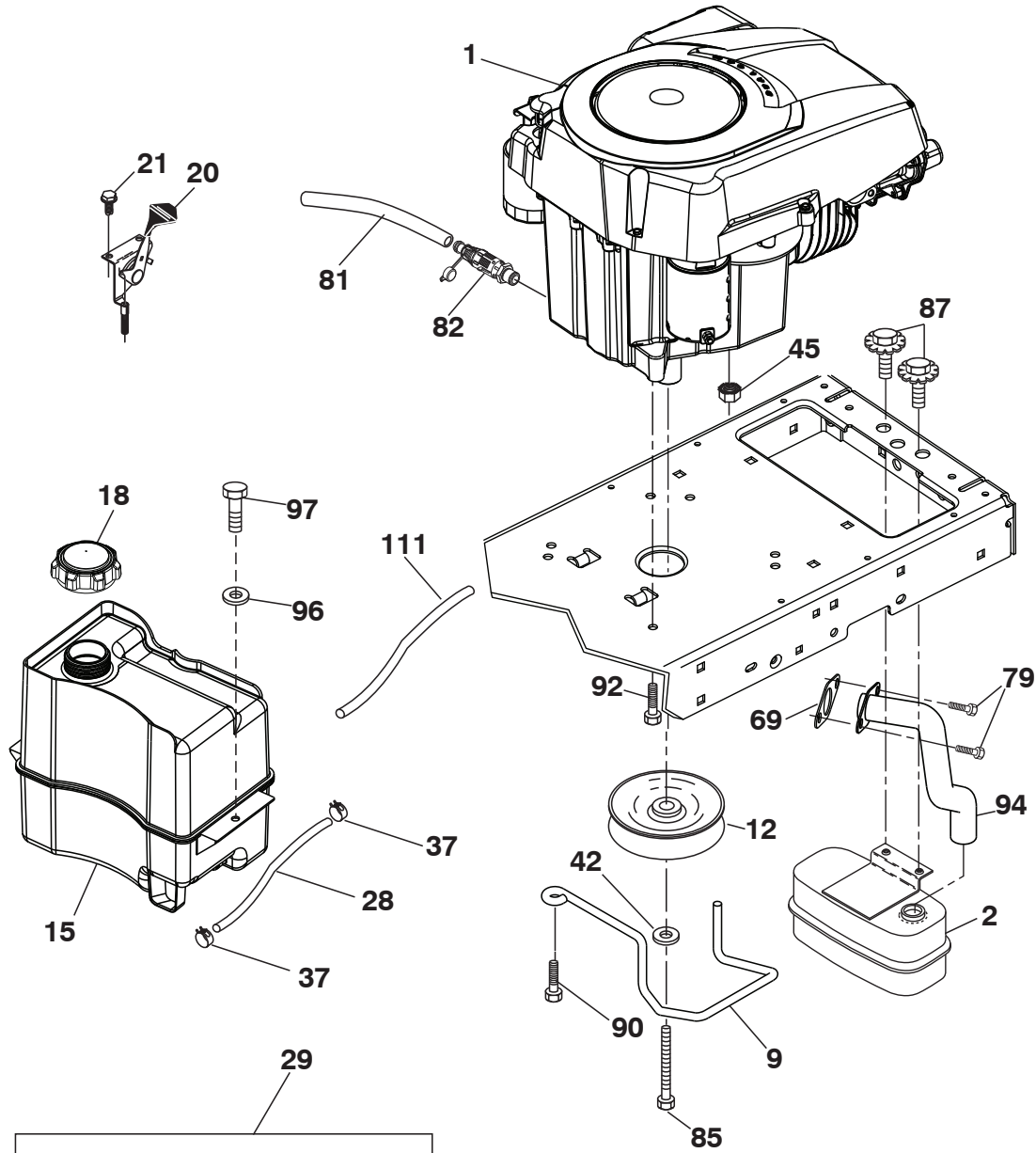

SPARK ARRESTER KIT

engine-tex_Kohl_31

**TRACTOR - - MODEL NUMBER 917.240460, PRODUCT NO. YTH20K46
ENGINE**

KEY NO.	PART NO.	DESCRIPTION
1	532 43 83-26	Engine Kohler Model No. SV600-3229
2	532 18 86-55	Muffler
9	532 19 43-20	Keeper Belt Engine
12	532 40 54-72	Pulley Engine
15	532 43 30-07	Tank Fuel
18	532 43 02-20	Cap Asm
20	532 40 15-08	Control Throttle/Choke
21	532 41 63-58	Screw #10 x 0.750 BOS Thread
28	532 40 11-37	Fuel Line
29	532 13 71-80	Spark Arrester Kit
37	532 12 34-87	Clamp Hose
42	810 04 07-00	Washer Lock 7/16
45	873 51 04-00	Nut Keps Hex 1/4-20 unc
69	532 18 59-09	Gasket
79	532 19 23-34	Screw Socket Head
81	532 14 84-56	Tube Drain Oil Easy
82	532 42 82-87	Valve Drain Oil
85	532 17 39-37	Bolt Hex 7/16-20 x 4 x Gr. 5-1.5 Thr
87	532 17 18-77	Bolt 5/16-18 unc x 3/4 w/Sems
90	817 00 06-16	Screw 3/8-16 x 1
92	817 12 06-16	Screw 3/8-16 x 1
94	532 18 86-54	Tube Exhaust
96	819 09 14-16	Washer 9/32 x 7/8 x 16 Ga.
97	817 67 04-12	Screw Hexwsh Thdrol 1/4-20 x 3/4
111	532 41 41-19	Purge Line

NOTE: All component dimensions given in U.S. inches
1 inch = 25.4 mm

For engine service and replacement parts, call the toll free number for your engine manufacturer listed below:

Kohler Co. 1-800-544-2444

TRACTOR - - MODEL NUMBER 917.240460, PRODUCT NO. YTH20K46
STEERING ASSEMBLY

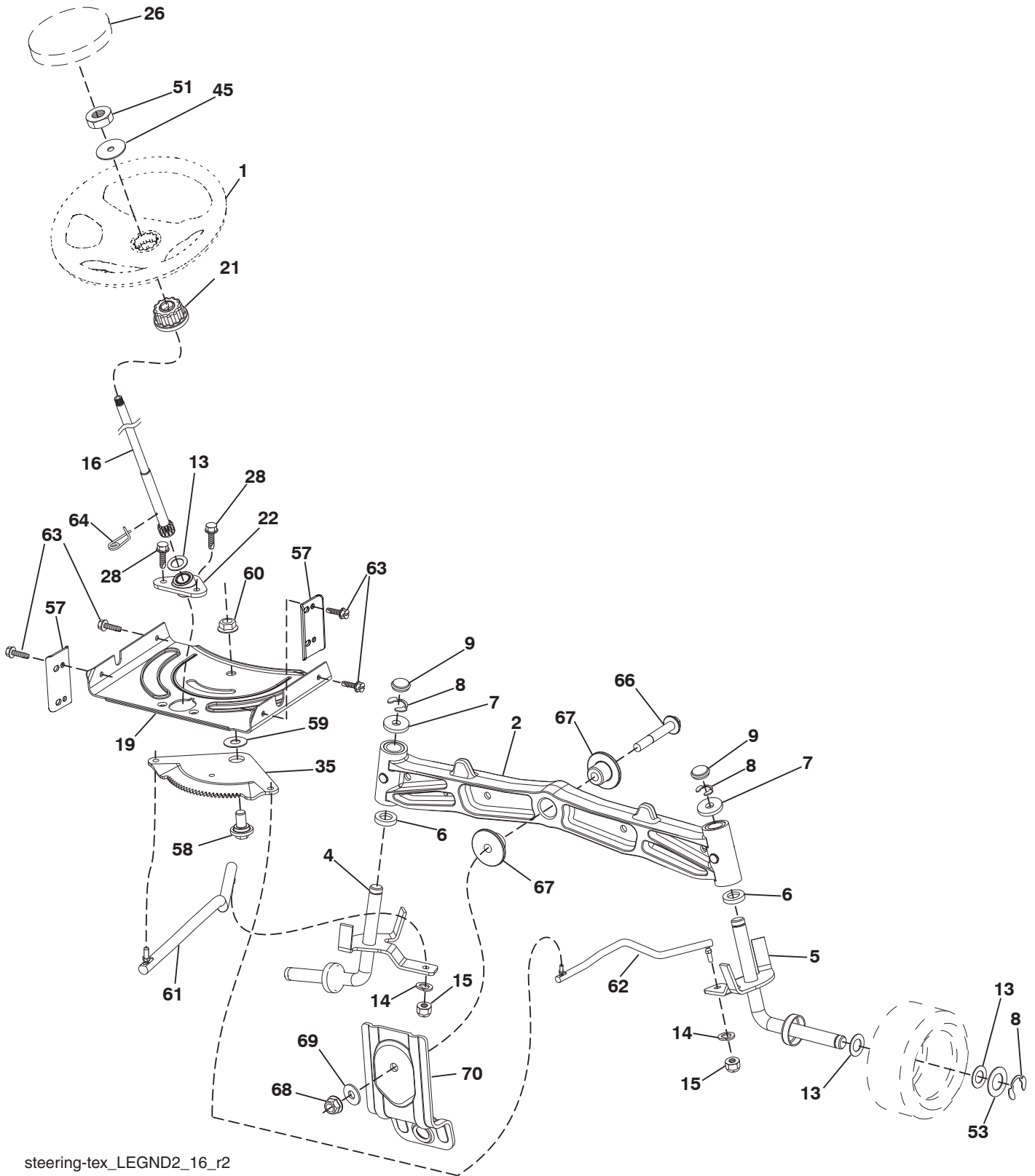

steering-tex_LEGND2_16_r2

**TRACTOR - - MODEL NUMBER 917.240460, PRODUCT NO. YTH20K46
STEERING ASSEMBLY**

KEY NO.	PART NO.	DESCRIPTION
1	532 43 97-40	Wheel, Steering
2	532 19 59-68	Axle Asm., Front
4	532 40 30-87	Spindle Asm., LH
5	532 40 30-88	Spindle Asm., RH
6	532 12 49-31	Bearing, Race Thrust Harden
7	532 12 17-48	Washer 25/32 x 1-5/8 x 16 Ga.
8	812 00 00-29	Ring, Klip #T5304-75
9	532 12 12-32	Cap, Spindle
13	532 12 17-49	Washer 25/32 x 1-1/4 x 16 Ga.
14	810 04 06-00	Washer, Lock Hvy Hlcl Spr 3/8
15	873 54 06-00	Nut, Crown Lock 3/8-24 unf
16	532 40 82-19	Shaft Steering
19	532 19 47-29	Plate Steering
21	532 18 67-37	Adapter, Wheel Steering
22	532 42 05-37	Support Strg. Lower
26	532 43 97-43	Insert, Wheel Steering
28	817 00 06-12	Screw 3/8-16 x 3/4
35	532 19 47-32	Gear, Sector Plate
45	819 18 38-12	Washer 9/16 ID x 2-3/8 OD 12 Ga.
51	873 94 08-00	Nut Hex Jam Toplock 1/2-20 unf
53	532 18 89-67	Washer Hardened. 793x1.637x.060
57	532 40 74-65	Bracket Upstop
58	532 19 47-47	Bolt Shoulder Sector Pivot CFM
59	532 19 47-48	Washer Thrust Sector Steering
60	873 97 10-00	Nut Flange Lock 5/8-11
61	532 19 47-40	Draglink LH
62	532 19 47-41	Draglink, RH
63	817 00 05-12	Screw 5/16-18 x 3/4
64	532 19 98-49	Retainer Clip Spring Steering
66	871 02 07-48	Bolt Hex Fghd 7/16-14 x 3 Serr
67	532 19 47-37	Bushing PM Front Axle
68	873 90 07-00	Nut Lock Flange 7/16-14 Gr. 5
69	532 19 91-62	Washer 1.5 x .505 x .118
70	532 19 61-97	Bracket Deck Susp. Front

NOTE: All component dimensions given in U.S. inches
1 inch = 25.4 mm

**TRACTOR - - MODEL NUMBER 917.240460, PRODUCT NO. YTH20K46
SEAT ASSEMBLY**

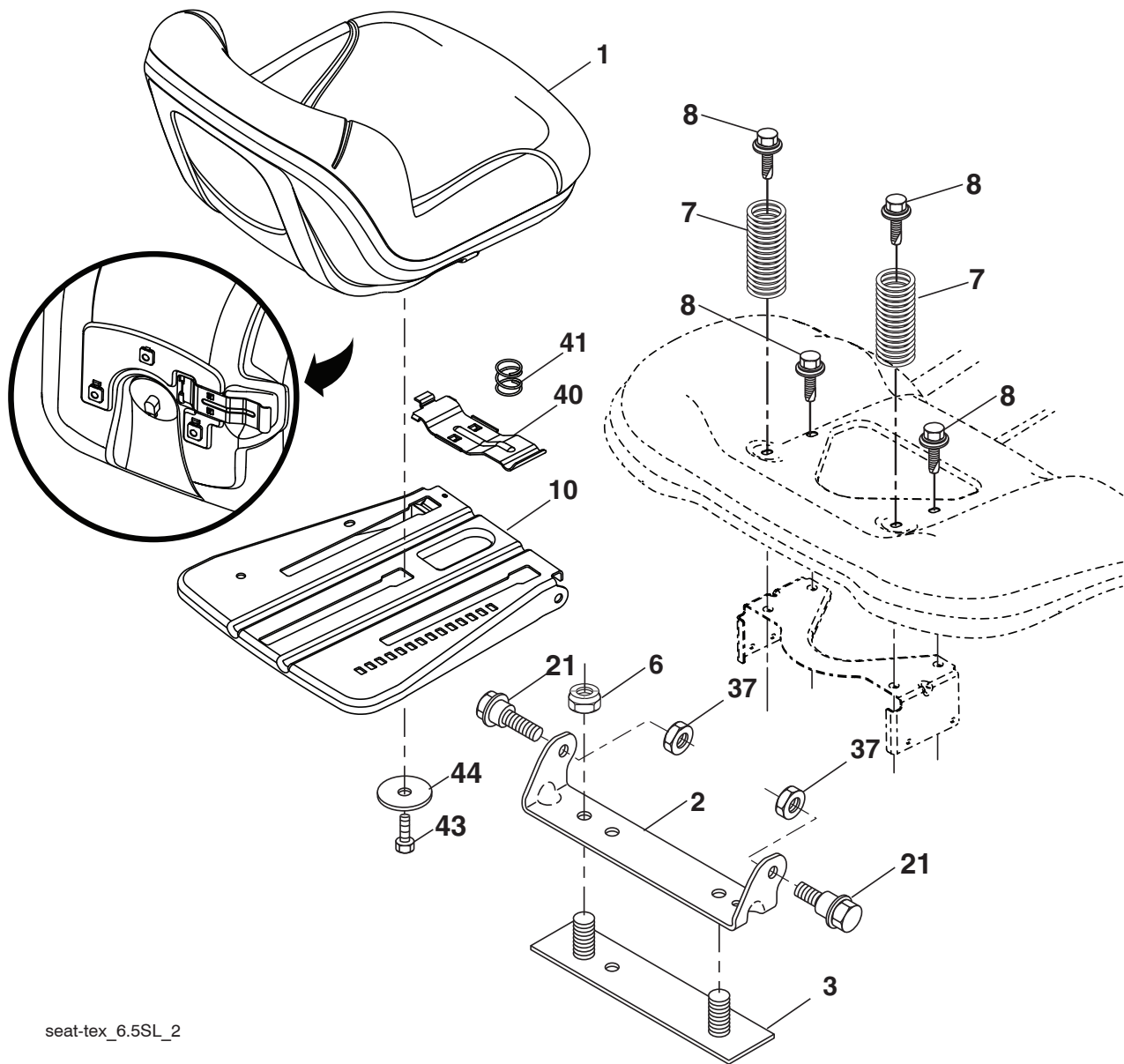

seat-tex_6.5SL_2

KEY NO.	PART NO.	DESCRIPTION
1	532 42 40-68	Seat
2	532 18 01-66	Bracket Pivot Fender
3	532 14 06-75	Strap, Asm Fender
6	873 80 06-00	Nut, Lock w/Ins. 3/8-16 unc
7	532 12 41-81	Spring, Seat Cprsn
8	532 17 18-77	Bolt 5/16-18 unc x 3/4 w/Sems
10	532 19 69-77	Pan, Seat
21	532 17 18-52	Bolt, Shoulder 5/16-18

KEY NO.	PART NO.	DESCRIPTION
37	873 80 05-00	Nut, Lock 5/16-18 unc
40	532 19 76-61	Handle Slide Seat
41	532 19 82-00	Spring Latch Seat
43	874 76 06-12	Bolt Fin Hex 3/8-16 unc x 3/4
44	819 13 38-12	Washer 13/32 x 2-3/8 x 12 Ga.

NOTE: All component dimensions given in U.S. inches
1 inch = 25.4 mm

**TRACTOR - - MODEL NUMBER 917.240460, PRODUCT NO. YTH20K46
MOWER LIFT**

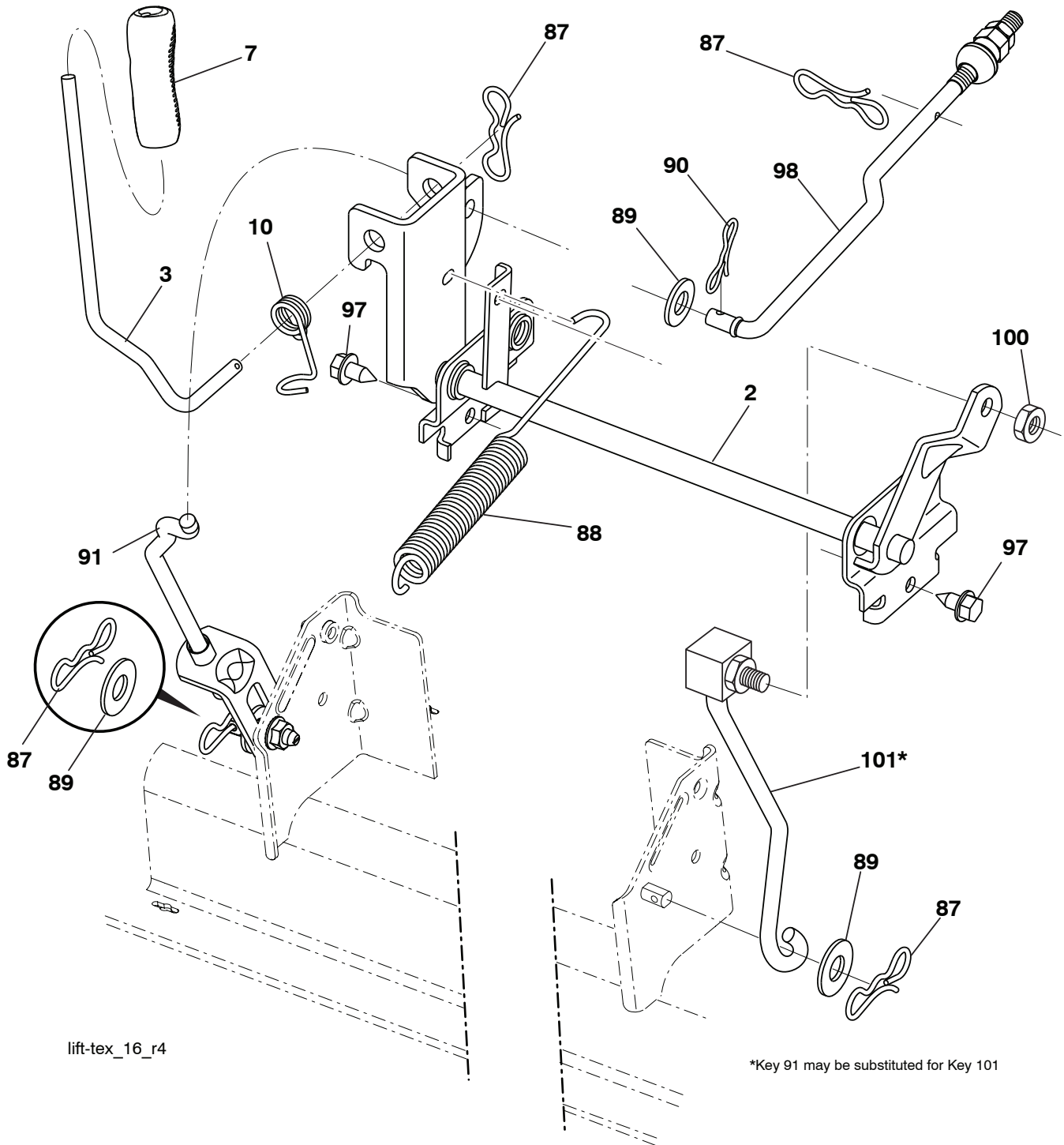

KEY NO.	PART NO.	DESCRIPTION
2	532 42 20-27	Shaft Asm., Lift
3	532 19 52-31	Lever Asm., Lift RH
7	532 41 15-55	Grip, Lever
10	532 19 63-14	Spring Torsion
87	532 19 42-09	Pin Cotter 7/16 Bow Tie Lock
88	532 41 07-10	Spring Lift Assist
89	819 19 19-12	Washer Clear Zinc
90	532 19 42-08	Pin Cotter 5/16 Bow Tie Lock
91	532 19 51-81	Link Lift Susp Mower Rear

KEY NO.	PART NO.	DESCRIPTION
97	817 00 06-12	Screw 3/8-16 x .75
98	532 19 52-70	Link Lift Susp. Front Mower
100	873 93 06-00	Nut Center Lock 3/8-16 unc
101	532 40 70-03	Link Asm. Lift FXD

NOTE: All component dimensions given in U.S. inches
1 inch = 25.4 mm

TRACTOR - - MODEL NUMBER 917.240460, PRODUCT NO. YTH20K46 MOWER DECK

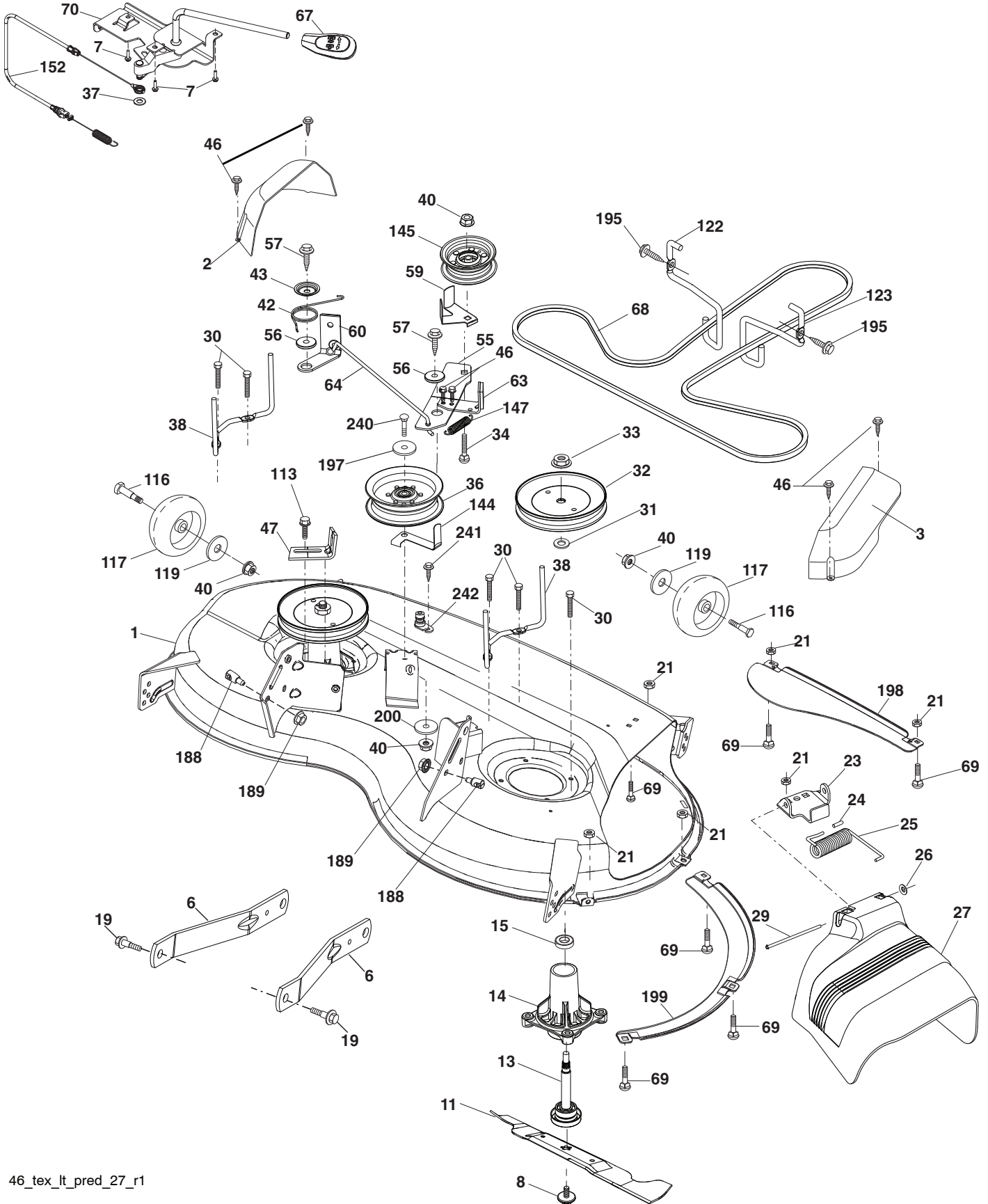

46_tex_lt_pred_27_r1

TRACTOR - - MODEL NUMBER 917.240460, PRODUCT NO. YTH20K46

MOWER DECK

KEY PART NO. NO.	DESCRIPTION	KEY PART NO. NO.	DESCRIPTION
1	532 44 23-82	60	532 19 94-71
2	532 40 55-06	63	532 19 94-77
3	532 40 55-07	64	532 40 51-38
6	532 19 51-86	67	532 40 30-12
7	532 41 63-58	68	532 40 51-43
8	532 19 30-03	69	872 14 05-05
11	532 40 53-80	70	532 19 99-72
- -	532 40 31-07	113	817 00 05-10
13	532 19 28-72	116	532 19 34-06
14	532 18 72-81	117	532 17 48-73
15	532 11 04-85	119	819 13 20-12
19	532 19 65-39	122	532 19 72-58
21	873 68 05-00	123	532 19 72-59
23	532 19 25-57	144	532 19 92-04
24	532 10 53-04	145	532 19 31-97
25	532 19 70-26	147	532 40 18-72
26	532 11 04-52	152	532 43 51-10
27	532 40 53-57	188	532 19 51-61
29	532 13 14-91	189	873 90 05-00
30	532 17 39-84	195	817 00 06-12
31	532 18 76-90	197	819 13 13-12
32	532 19 74-73	198	532 40 31-49
33	532 40 02-34	199	532 40 31-50
34	872 11 06-12	200	532 41 35-24
36	532 19 73-79	240	874 52 06-36
37	819 13 13-16	241	532 15 29-27
38	532 43 25-20	242	532 41 55-98
40	873 90 06-00	- -	532 41 64-05
42	532 19 84-10	- -	532 19 28-70
43	532 19 72-56		
46	532 13 77-29		
47	532 19 72-50		
55	532 19 72-49	- -	532 43 18-23
56	532 19 90-92		
57	817 00 06-16		
59	532 14 10-43		

NOTE: All component dimensions given in U.S. inches
1 inch = 25.4 mm

**TRACTOR - - MODEL NUMBER 917.240460, PRODUCT NO. YTH20K46
DECALS**

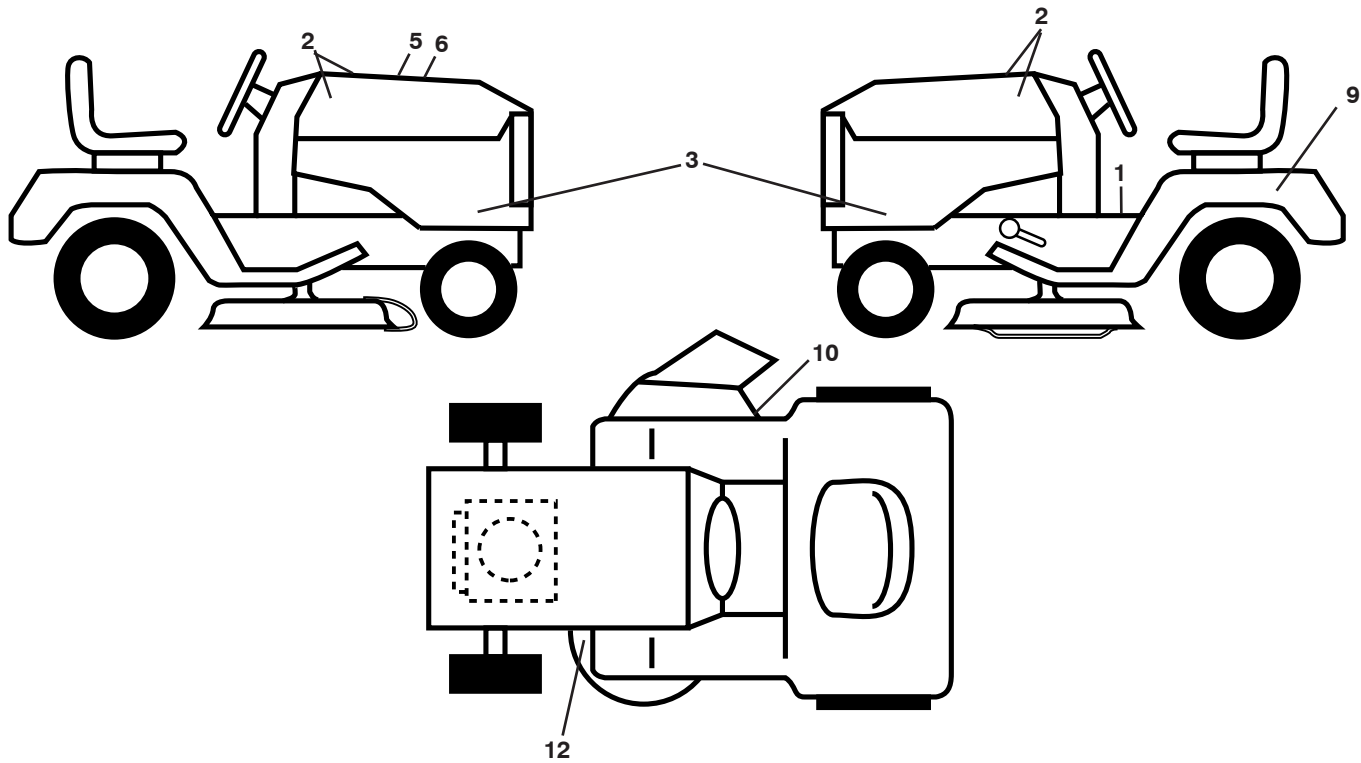

KEY NO.	PART NO.	DESCRIPTION	KEY NO.	PART NO.	DESCRIPTION
1	532 41 16-57	Decal, Operators	12	532 16 03-96	Decal, Mower V-Belt Schematic
2	532 42 91-96	Decal, Badge	--	532 16 69-60	Decal, Bypass
3	532 44 14-81	Decal, Hood Panel SD	--	532 43 96-81	Pad, Footrest, LH
5	532 42 38-29	Decal, Customer Respons.	--	532 43 96-82	Pad, Footrest, RH
6	532 44 14-53	Decal, Replacement	--	532 44 14-57	Manual, Owner's (English)
9	532 14 50-05	Decal, Battery Dnge/Poi	--	532 44 17-18	Manual, Owner's (Spanish)
10	532 17 05-63	Decal, Warning			

WHEELS AND TIRES

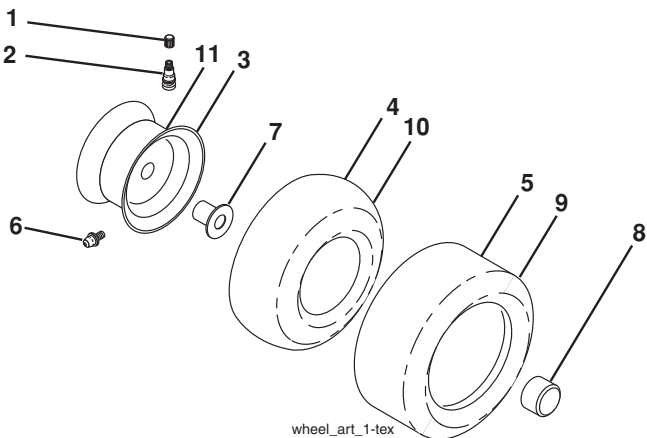

KEY NO.	PART NO.	DESCRIPTION
1	532 05 91-92	Cap Valve Tire
2	532 06 51-39	Stem Valve
3	532 13 83-36	Rim Front Service
4	532 05 99-04	Tube Front (Service Item Only)
5	532 10 62-22	Tire Front 15 x 6.0-6 Service
6	532 12 49-57	Fitting Grease (Front Wheel Only)
7	532 12 49-59	Bearing Flange (Front Wheel Only)
8	532 17 50-39	Cap Axle Blk 1 50 x 1 00
9	532 13 84-68	Tire R Ts 20 x 8-8
10	532 12 49-26	Tube Rear (Service Item Only)
11	532 13 83-37	Rim Asm 8" rear Service
--	532 14 43-34	Sealant, Tire (10 oz. Tube)

NOTE: All component dimensions given in U.S. inches
1 inch = 25.4 mm

**TRACTOR - - MODEL NUMBER 917.240460, PRODUCT NO. YTH20K46
TUFFTORQ TRANSAXLE MODEL NUMBER K46BT**

**MODEL K46BT
7A646084180**

ACTUAL PARTS
MAY NOT APPEAR
AS SHOWN

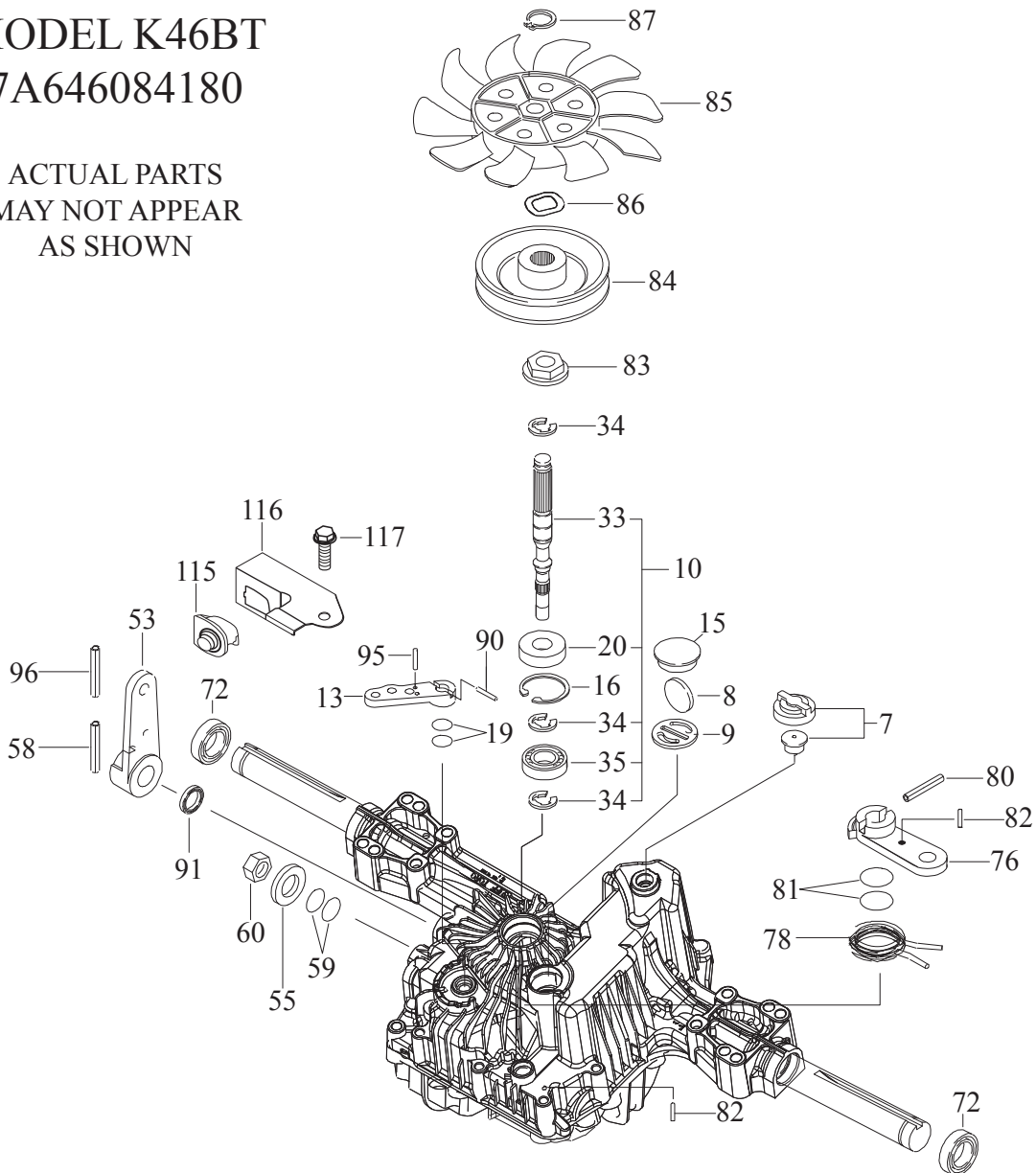

KEY NO.	PART NO.	DESCRIPTION
7	414395	Vent Valve 15
8	414396	Magnet
9	414397	Magnet Holder
10	415923	Pump Shaft/Bearing Kit
13	414398	Bypass Lever
15	414399	Sealing Cap 30
16	414400	Snap Ring C 35
19	414401	O-Ring 1a P10a
20	414402	Seal Tc 153507
33	414403	Pump Shaft (Standard)
34	414404	E-Ring 15
35	414405	Bearing 6202c3
53	414431	Control Lever F
55	415924	Washer 12
58	415925	Roll Pin 6 * 40
59	415926	O-Ring 1a P14
60	415927	Nut 12
72	414407	Seal 19 * 32 * 8
76	414408	Brake Lever

KEY NO.	PART NO.	DESCRIPTION
78	414409	Brake Return Spring
80	414410	Spring Pln 5 * 32
81	414411	O-Ring 1a P12
82	414412	Spring Pin 4 * 16
83	414413	Spine Collar
84	414414	Pulley L
85	414415	Fan, Black
86	414416	Wave Washer
87	414417	Snap Ring
90	414418	Spring Pin 3.0a * 20
91	414419	Oil Seal 16 * 22 *.03
95	414850	Spring Pin 3.0a*16
96	414420	Roll Pin 3.5 * 40
115	415928	Switch 6440-11 Delta
116	415929	Switch Bracket
117	415930	Tapping Screw 8 * 20

NOTE: All component dimensions given in U.S. inches
1 inch = 25.4 mm

TRACTOR - - MODEL NUMBER 917.240460, PRODUCT NO. YTH20K46
KOHL ENGINE - MODEL NO. SV600-3229

CRANKSHAFT 1-20-4

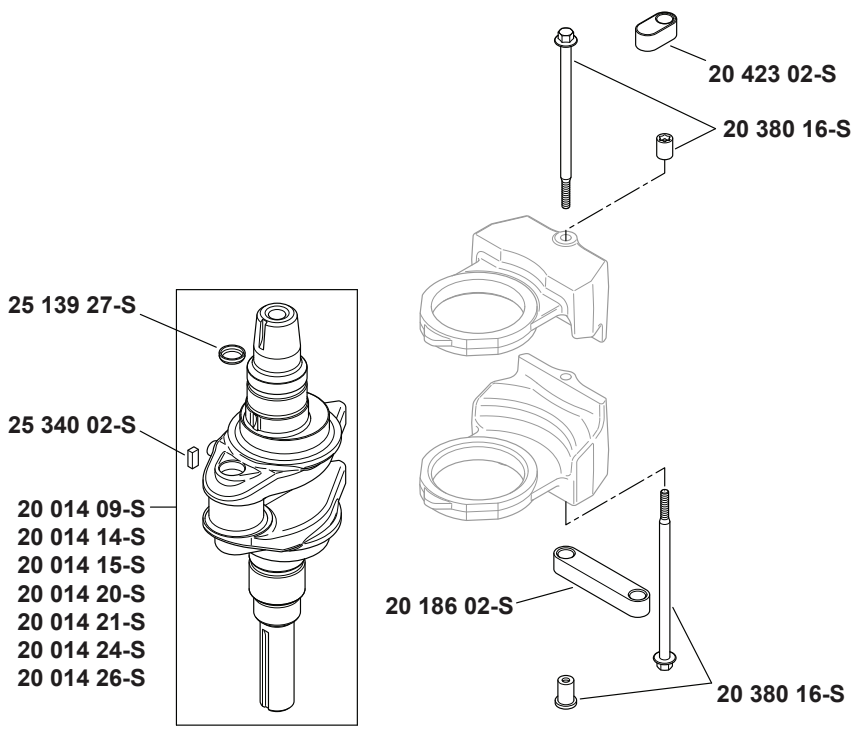
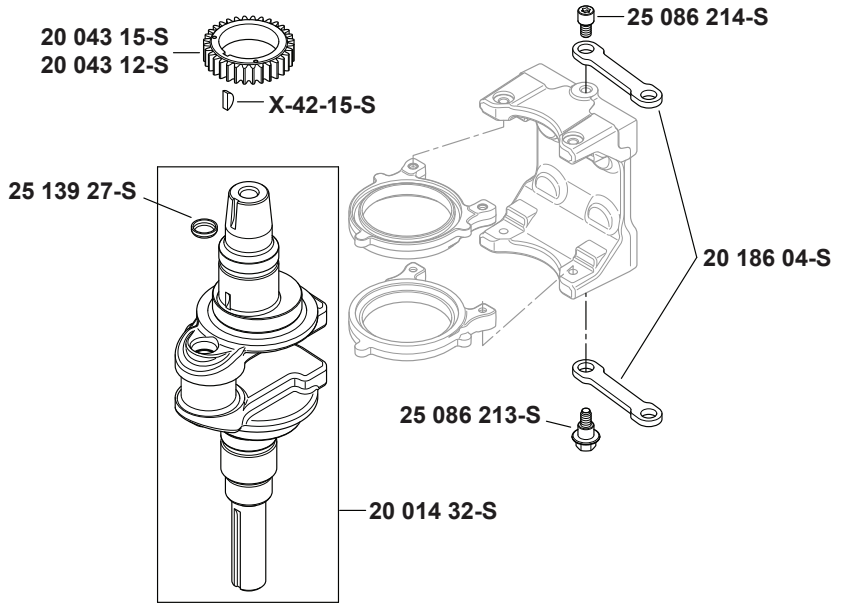

TRACTOR - - MODEL NUMBER 917.240460, PRODUCT NO. YTH20K46
KOHL ENGINE - MODEL NO. SV600-3229

CRANKCASE 2-20-22

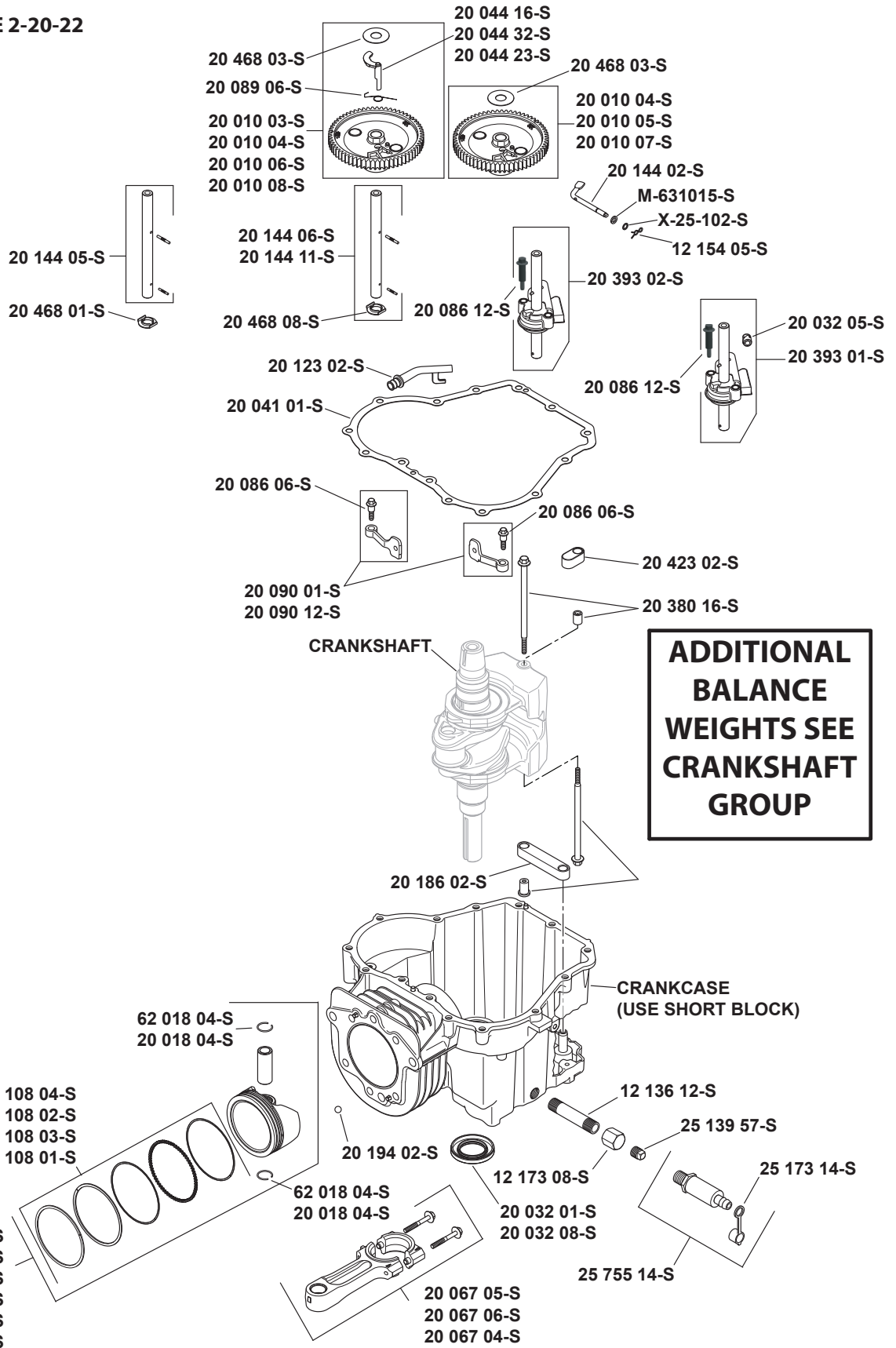

TRACTOR - - MODEL NUMBER 917.240460, PRODUCT NO. YTH20K46
KOHL ENGINE - MODEL NO. SV600-3229

OIL PAN/LUBRICATION 3-20-40

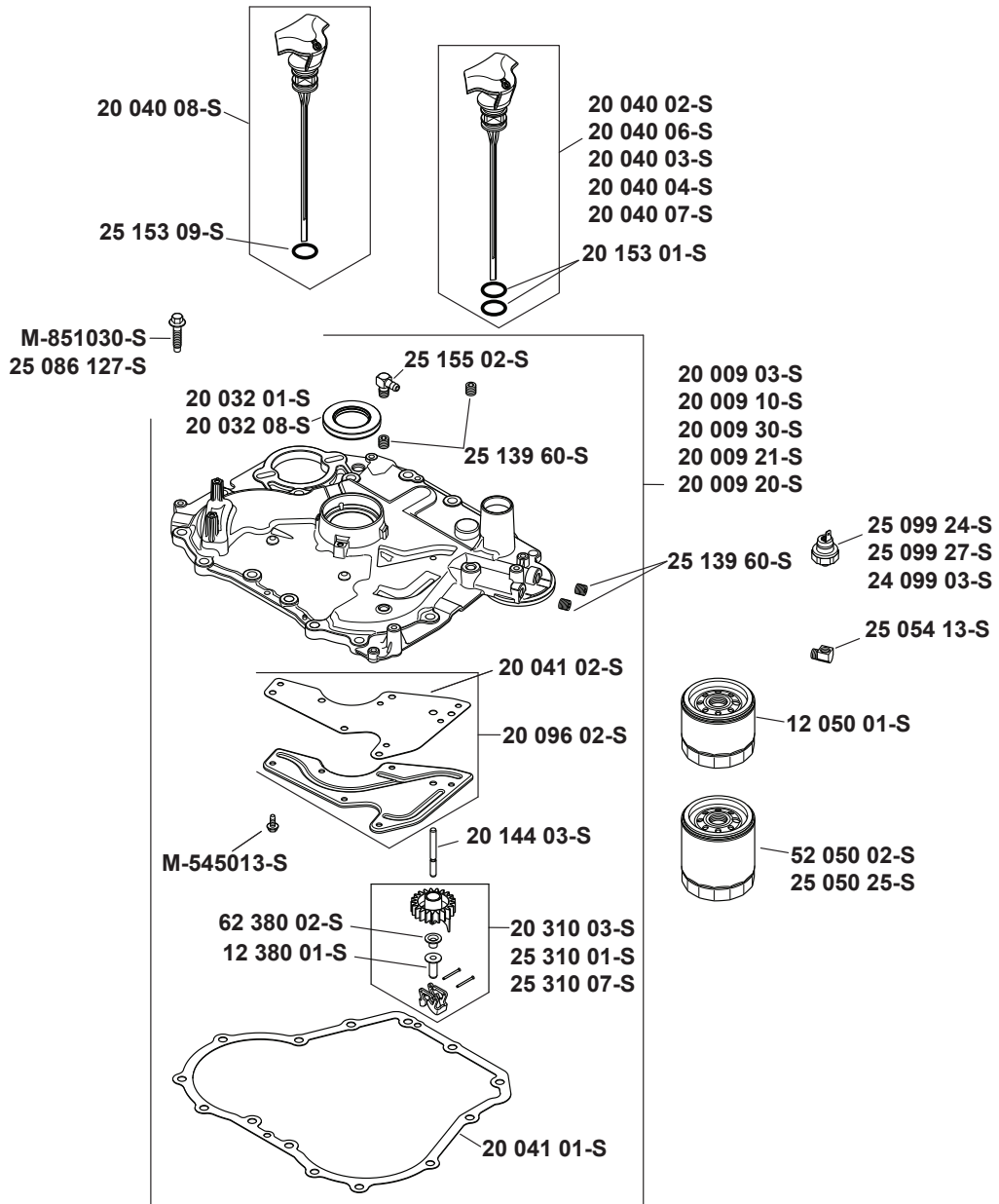

TRACTOR - - MODEL NUMBER 917.240460, PRODUCT NO. YTH20K46
KOHL ENGINE - MODEL NO. SV600-3229

HEAD/VALVE/BREATHER 4-20-19

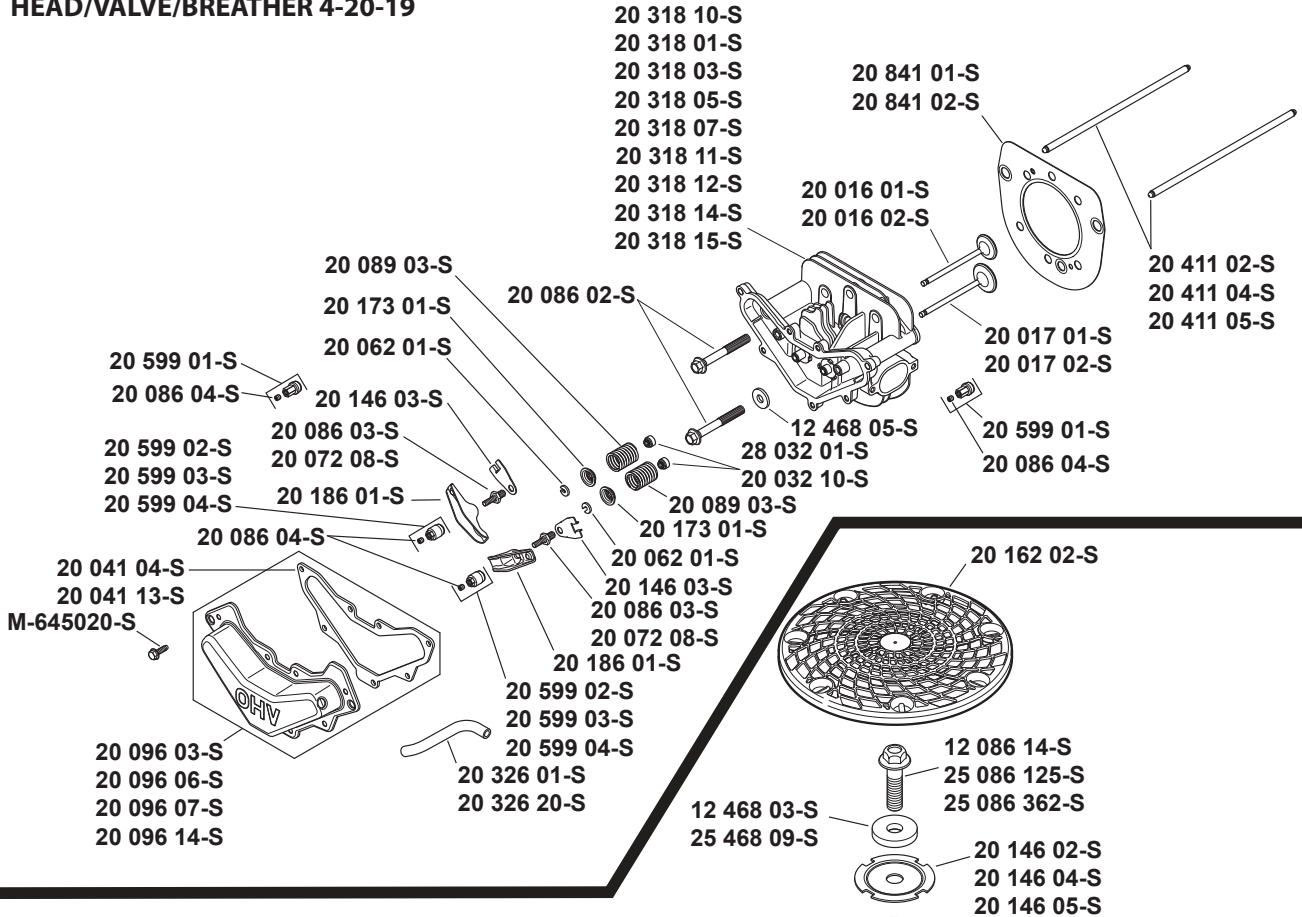

IGNITION/ELECTRICAL 5-20-41

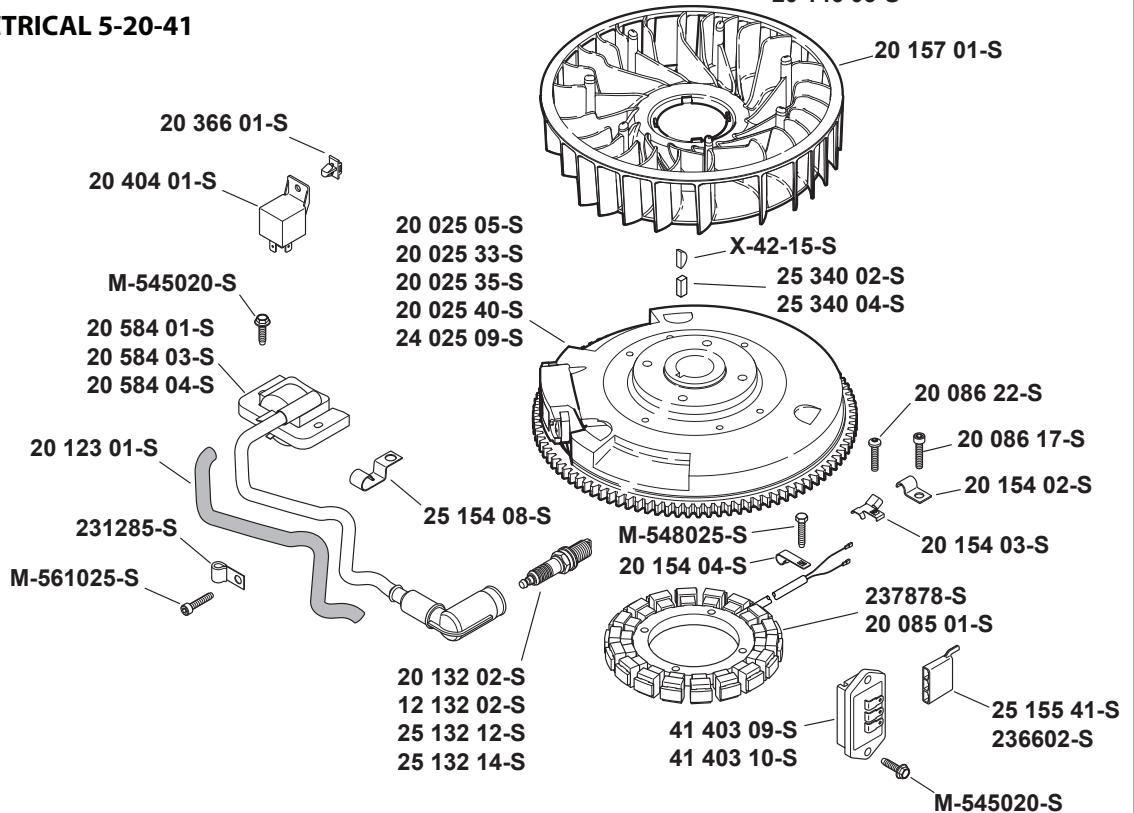

TRACTOR - - MODEL NUMBER 917.240460, PRODUCT NO. YTH20K46
KOHL ENGINE - MODEL NO. SV600-3229

BLOWER HOUSING & BAFFLES 6-20-7

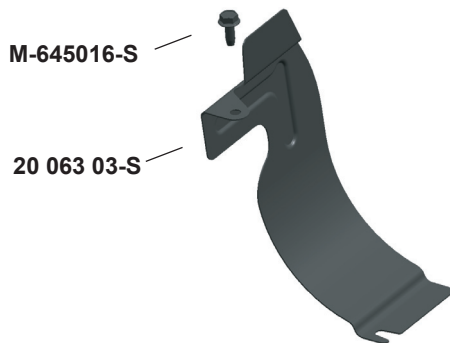
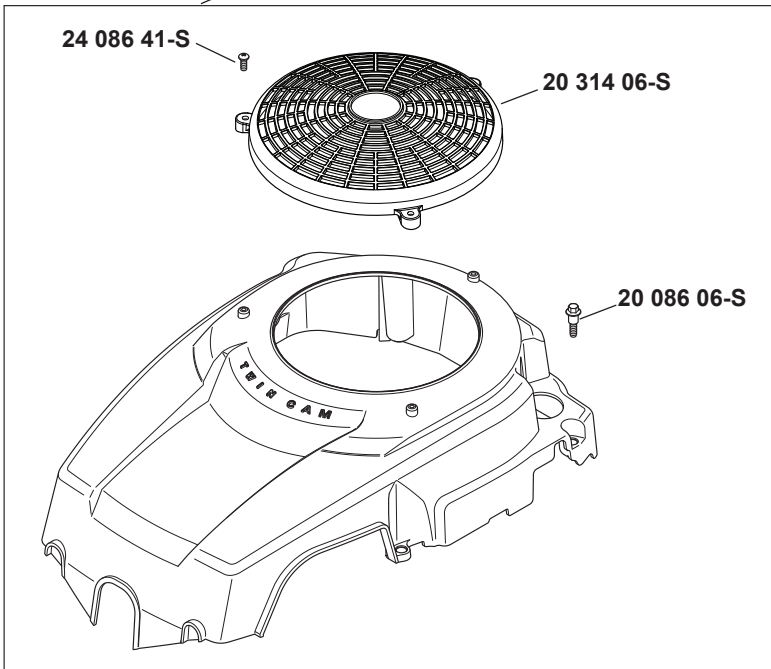
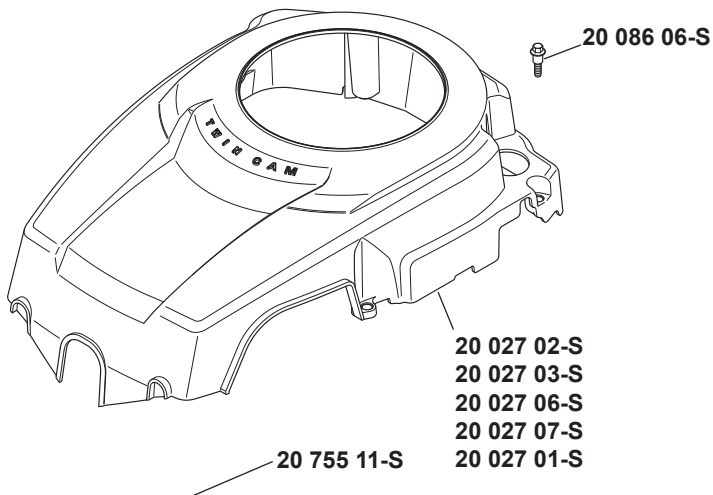

STARTING SYSTEM 7-20-1

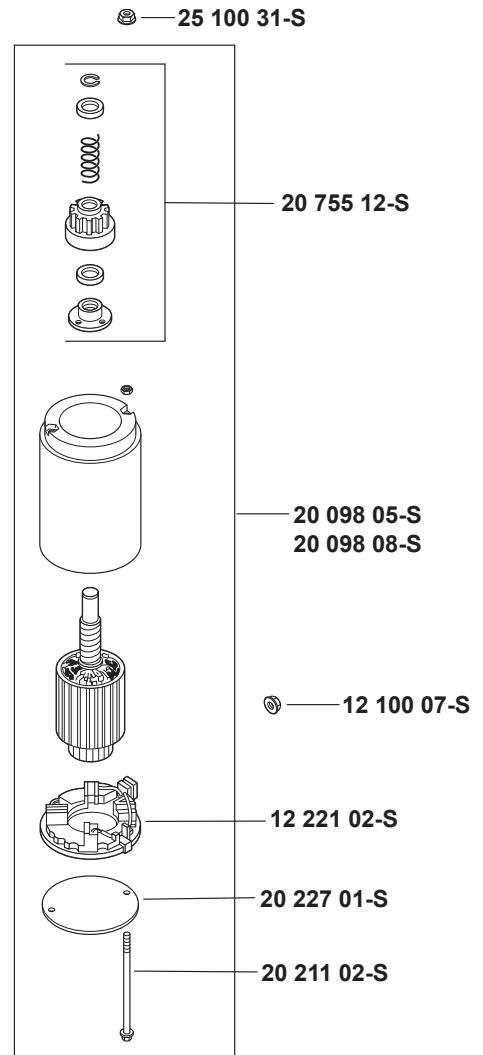
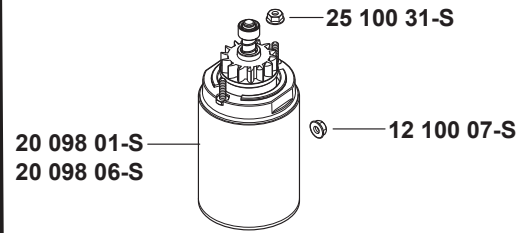

TRACTOR - - MODEL NUMBER 917.240460, PRODUCT NO. YTH20K46
KOHL ENGINE - MODEL NO. SV600-3229

FUEL SYSTEM 8-20-132

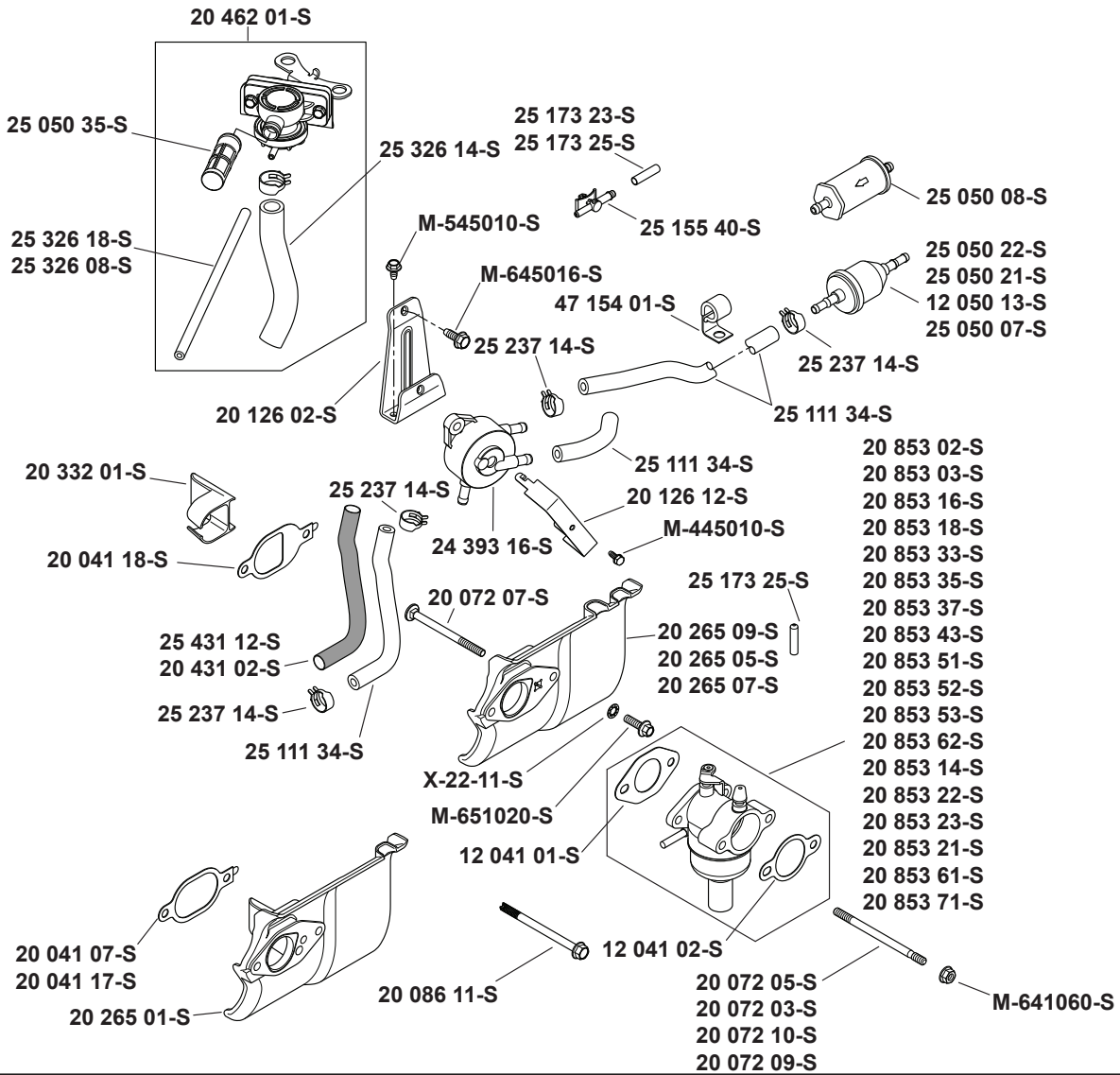

ENGINE CONTROLS 9-20-8

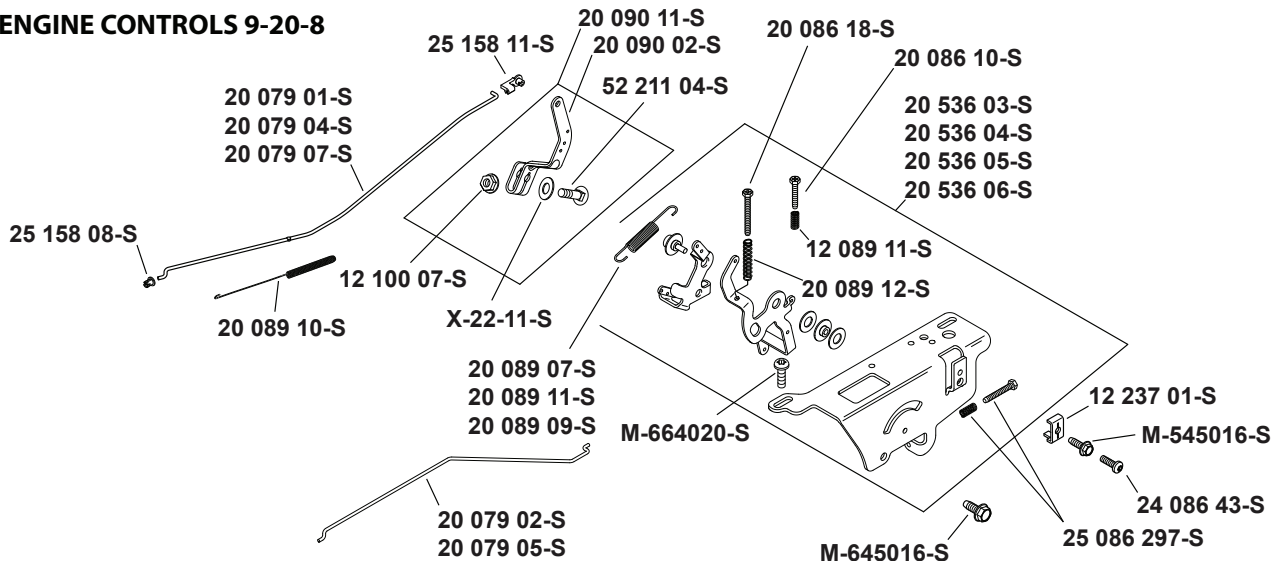

TRACTOR - - MODEL NUMBER 917.240460, PRODUCT NO. YTH20K46
KOHL ENGINE - MODEL NO. SV600-3229

AIR INTAKE/FILTRATION 10-20-12

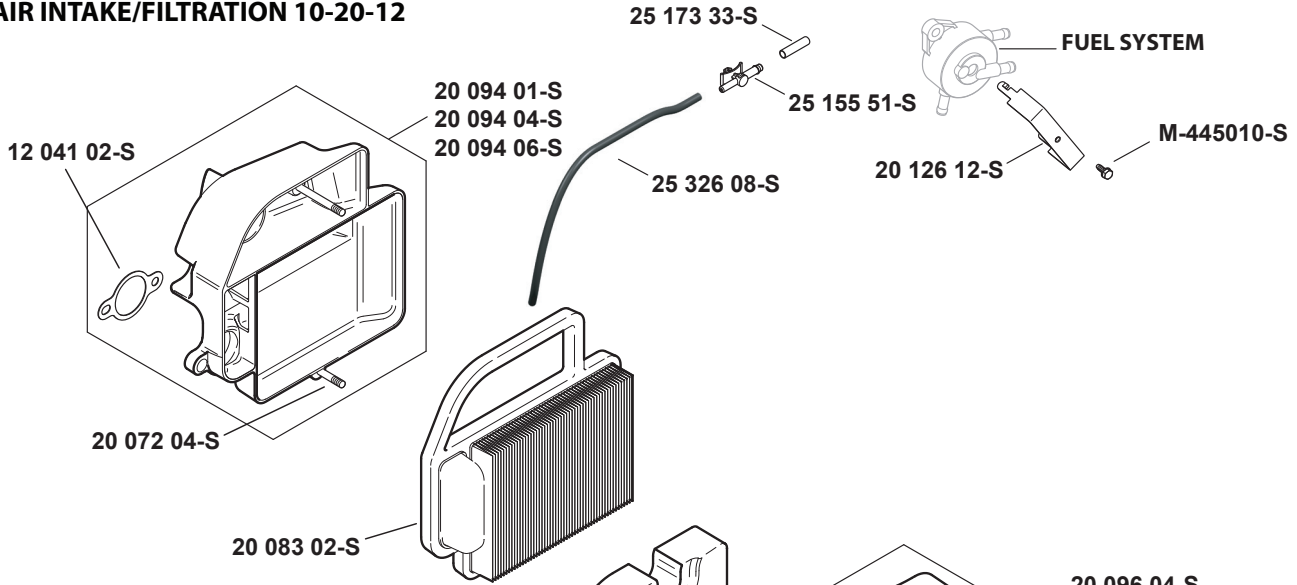

DECALS 12-20-23

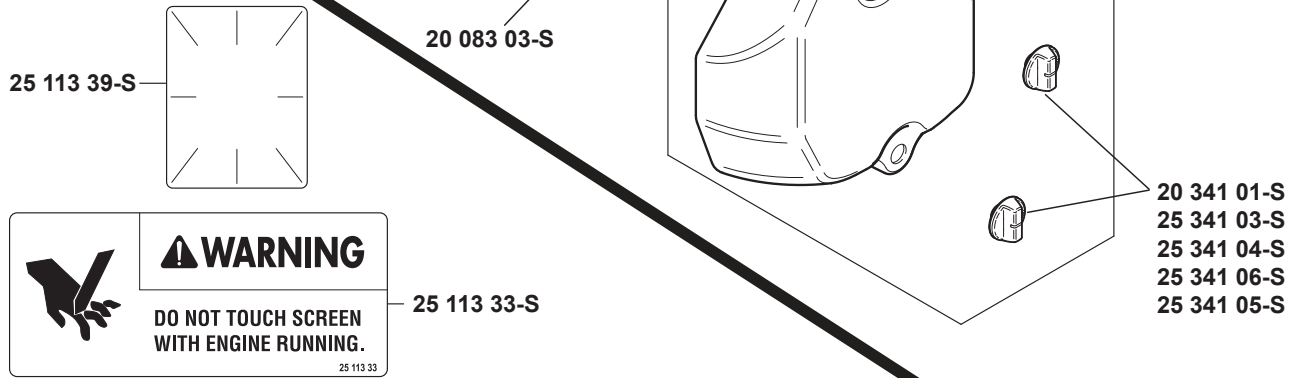

WARNING
 DO NOT TOUCH SCREEN
 WITH ENGINE RUNNING.
25 113 33

- | | | |
|-------------|--|-------------|
| 20 113 09-S | | 20 113 35-S |
| 20 113 10-S | | 20 113 21-S |
| 20 113 11-S | | 20 113 22-S |
| 20 113 12-S | | 20 113 31-S |
| 20 113 13-S | | 20 113 26-S |
| 20 113 14-S | | 20 113 41-S |
| 20 113 15-S | | 20 113 25-S |
| 20 113 27-S | | 20 113 28-S |
| 20 113 36-S | | 20 113 34-S |
| 20 113 48-S | | 20 113 38-S |
| 20 113 49-S | | 20 113 51-S |
| 20 113 55-S | | 20 113 50-S |
| 20 113 56-S | | 20 113 52-S |
| 20 113 57-S | | 20 113 53-S |
| 20 113 58-S | | |
| | | 20 113 24-S |
| | | 20 113 37-S |
| | | 20 113 23-S |
| | | 20 113 30-S |
| | | 20 113 54-S |
| | | 20 113 54-S |

Artwork is representative.
 Actual labels may differ depending on model and specification number.

TRACTOR - - MODEL NUMBER 917.240460, PRODUCT NO. YTH20K46
KOHL ENGINE - MODEL NO. SV600-3229

Crankshaft 1-20-4

Part No.	Description
20 014 32-S	CRANKSHFT ASSY USE 20 014 43-S (includes 25 139 27-S)
25 139 27-S	PLUG, CUP
X-42-15-S	KEY, 3/16" X 5/8"
20 043 15-S	GEAR, CRANKSHAFT
25 086 214-S	SCREW, LINK PIVOT
20 186 04-S	LINKAGE, BALANCE WEIGHT
25 086 213-S	SCREW, SHOULDER

Crankcase 2-20-22

Part No.	Description
25 139 57-S	PLUG, SQ HD PIPE 3/8"
20 032 08-S	SEAL, OIL
20 067 05-S	ROD, CONNECTING ASSEMBLY
20 874 16-S	KIT, PISTON,RINGS & PIN ASSY 94mm BORE
62 018 04-S	RETAINER, PISTON PIN
12 154 05-S	CLIP, HITCH PIN
20 144 02-S	SHAFT, GOVERNOR CROSS
M-631015-S	WASHER, FLAT 6 MM
X-25-102-S	WASHER, FLAT 1/4"
20 086 12-S	SCREW, SHD THD FRM - DISC.
20 393 02-S	KIT, OIL PUMP ASSEMBLY
20 010 07-S	CAM LOBE ASSEMBLY
20 010 08-S	CAM GEAR ASSEMBLY
20 086 06-S	SCREW, SHD THD FRM M6X1X26
20 089 06-S	SPRING, ACR
20 144 11-S	KIT,CAM CENTER SHAFT (EXHAUST)
20 393 01-S	KIT, OIL PUMP (SHALLOW 10mm)
20 468 03-S	WASHER, THRUST -ACR
20 468 08-S	WASHER, THRUST
20 123 02-S	TUBE , DRAINBACK

Oil Pan/Lubrication 3-20-40

Part No.	Description
20 009 30-S	CLOSURE PLATE ASSEMBLY
20 032 08-S	SEAL, OIL
20 041 01-S	GASKET, CLOSURE PLATE
25 086 127-S	HEX FLANGE SCREW,1/2 DOG POINT
12 380 01-S	PIN, GOVERNOR REGULATING
20 144 03-S	SHAFT, GOVERNOR CROSS
25 310 07-S	KIT, GOVERNOR GEAR ASSY
20 041 02-S	GASKET, OIL PASSAGE
20 096 02-S	KIT, OIL PASSAGE COVER
M-545013-S	SCREW, FLG THD FRM M5X0.8X13
52 050 02-S	FILTER, OIL
20 040 08-S	BLADE, DIPSTICK ASSEMBLY
25 153 09-S	O-RING

Head/Valve/Breather 4-20-19

Part No.	Description
12 468 05-S	WASHER, FLAT 13/32"
20 841 01-S	KIT, CYLINDER HEAD GASKET
20 086 02-S	SCREW, CYLINDER HEAD (M10 X 80)
20 318 14-S	KIT, CYLINDER HEAD
20 016 01-S	VALVE, EXHAUST
20 017 01-S	VALVE, INTAKE
20 032 10-S	SEAL, VALVE STEM
20 062 01-S	LOCK, RETAINER
20 089 03-S	SPRING, VALVE
20 173 01-S	CAP, VALVE SPRING
20 072 08-S	STUD, ROCKER

20 146 03-S	PLATE, PUSH ROD GUIDE
20 186 01-S	ARM, ROCKER
20 411 05-S	ROD, PUSH
20 599 04-S	ROCKER PIVOT ASSEMBLY
20 041 13-S	GASKET, VALVE COVER
20 096 07-S	KIT, VALVE COVER USE 20 096 14-S
M-645020-S	SCREW, FLG THD FRM M6X1.0X20
20 326 20-S	HOSE, BREATHER

Ignition/Electrical 5-20-41

Part No.	Description
237878-S	KIT, 15 / 20 AMP STATOR
M-548025-S	SCREW, THD FRM M5X0.8X25
20 025 40-S	FLYWHEEL
25 086 362-S	SCREW, HEX FLANGE
25 340 04-S	KEY, SQUARE
25 468 09-S	WASHER, FLAT
20! 584 04-S	MODULE, IGNITION
M-545020-S	SCREW, FLG THD FRM M5X.8X20
20 146 05-S	PLATE, FAN MOUNTING
20 157 01-S	FAN
20 162 02-S	SCREEN, GRASS
12 132 02-S	PLUG, SPARK (STD)
41 403 10-S	REGULATOR/RECTIFIER
M-545020-S	SCREW, FLG THD FRM M5X.8X20
20 154 04-S	CLIP, WIRE
20 176 13-S	HARNES, WIRING NOT ILLUSTRATED
25 155 41-S	CONNECTOR
25 454 05-S	TIE NOT ILLUSTRATED

Blower Housing & Baffles 6-20-7

Part No.	Description
20 027 07-S	KIT, BLOWER HOUSING
20 063 03-S	BAFFLE, BARREL
20 086 06-S	SCREW, SHD THD FRM M6X1X26
M-645016-S	SCREW, FLG THD FRM M6X1.0X16

Starting System 7-20-1

Part No.	Description
20 098 08-S	STARTER ASSEMBLY (SERVICE WITH 12 221 02-S, 20 755 12-S, 20 227 01-S, 20 211 02-S)
25 10 0 31-S	NUT, FREE SPINNING FLG #10-24
20 755 12-S	KIT, DRIVE (J.E.)
12 221 02-S	BRUSH KIT
20 227 01-S	CAP, DRIVE END (J.E.)
20 211 02-S	BOLT, THRU

Fuel System 8-20-132

Part No.	Description
20 853 71-S	KIT, CARBURETOR
25 454 05-S	TIE NOT ILLUSTRATED
20 072 05-S	STUD, M6X1.0X100
M-641060-S	NUT, FLG M6X1.0
X-22-11-S	WASHER, INT TOOTH LOCK 1/4"
M-651020-S	SCREW, FLG M6x1.0x20
20 041 18-S	GASKET, HEAT DEFLECTOR
20 072 07-S	STUD, CARBURETOR
20 265 09-S	KIT, HEAT DEFLECTOR
25 050 21-S	FILTR,FUEL 75 MICRON (GRAVITY FEED)
25! 111 34-S	LINE, FUEL (24"-CUT TO LENGTH)
25 237 14-S	CLAMP, HOSE 1/2" USE 25 237 31-S

TRACTOR - - MODEL NUMBER 917.240460, PRODUCT NO. YTH20K46
KOHL ENGINE - MODEL NO. SV600-3229

Engine Controls 9-20-8

Part No.	Description
20 536 06-S	KIT, SPEED CONTROL ASSEMBLY (INCLUDES 25 086 297-S, 20 089 12-S, M-66420-S [QTY.1], 20 089 11-S, 20 086 18-S, 20 086 10-S , 12 089 11-S)
25 086 297-S	KIT, IDLE ADJ SCREW & SPRING
20 089 12-S	SPRING, SPEED CONTROL (LONG)
12 237 01-S	CLAMP, CABLE
M-664020-S	SCREW, LBD SKT M6x1.0x20
12 089 11-S	SPRING, SPEED CONTROL (SHORT)
20 090 11-S	LEVER, GOVERNOR ASSEMBLY
52 211 04-S	BOLT, RD HD SQ NCK 1/4-20X1"
X-22-11-S	WASHER, INT TOOTH LOCK 1/4"
12 100 07-S	NUT, FLANGE 1/4-20
25 158 11-S	BUSHING, THROTTLE LINKAGE
20 079 07-S	LINKAGE, THROTTLE
25 158 08-S	BUSHING, LINKAGE RETAINING
20 089 10-S	SPRING, LINKAGE
20 071 9 05-S	LINKAGE, CHOKE
20 086 18-S	SCREW, PHL THD FRM M4X0.7X38
24 086 43-S	SCREW, LBD THD FRM M5x0.8x16
20 086 10-S	SCREW, PHL THD FRM M4X0.7X25
12 089 11-S	SPRING, SPEED CONTROL (SHORT)

Air Intake/Filtration 10-20-12

Part No.	Description
20 072 04-S	STUD, AIR CLEANER BASE
12 041 02-S	GASKET, AIR CLEANER BASE
20 083 02-S	ELEMENT, AIR CLEANER
20 096 04-S	KIT, AIR CLEANER COVER
25 341 04-S	KNOB, COVER
25 155 51-S	CONNECTOR, EVAPORATIVE
25 173 33-S	CAP, MASKING
25 326 08-S	HOSE, EVAPORATIVE, 20"
20 094 06-S	BASE, AIR CLEANER W/EVAP CONNECTION

Decals 12-20-23

Part No.	Description
25 113 39-S	DECAL, CLEAR LAMINATE
20 113 36-S	DECAL, 20HP
20 113 37-S	DECAL, WING SET

ACCESSORIES

Part No.	Description
20 041 12-S	GASKET, EXHAUST

SUGGESTED GUIDE FOR SIGHTING SLOPES FOR SAFE OPERATION

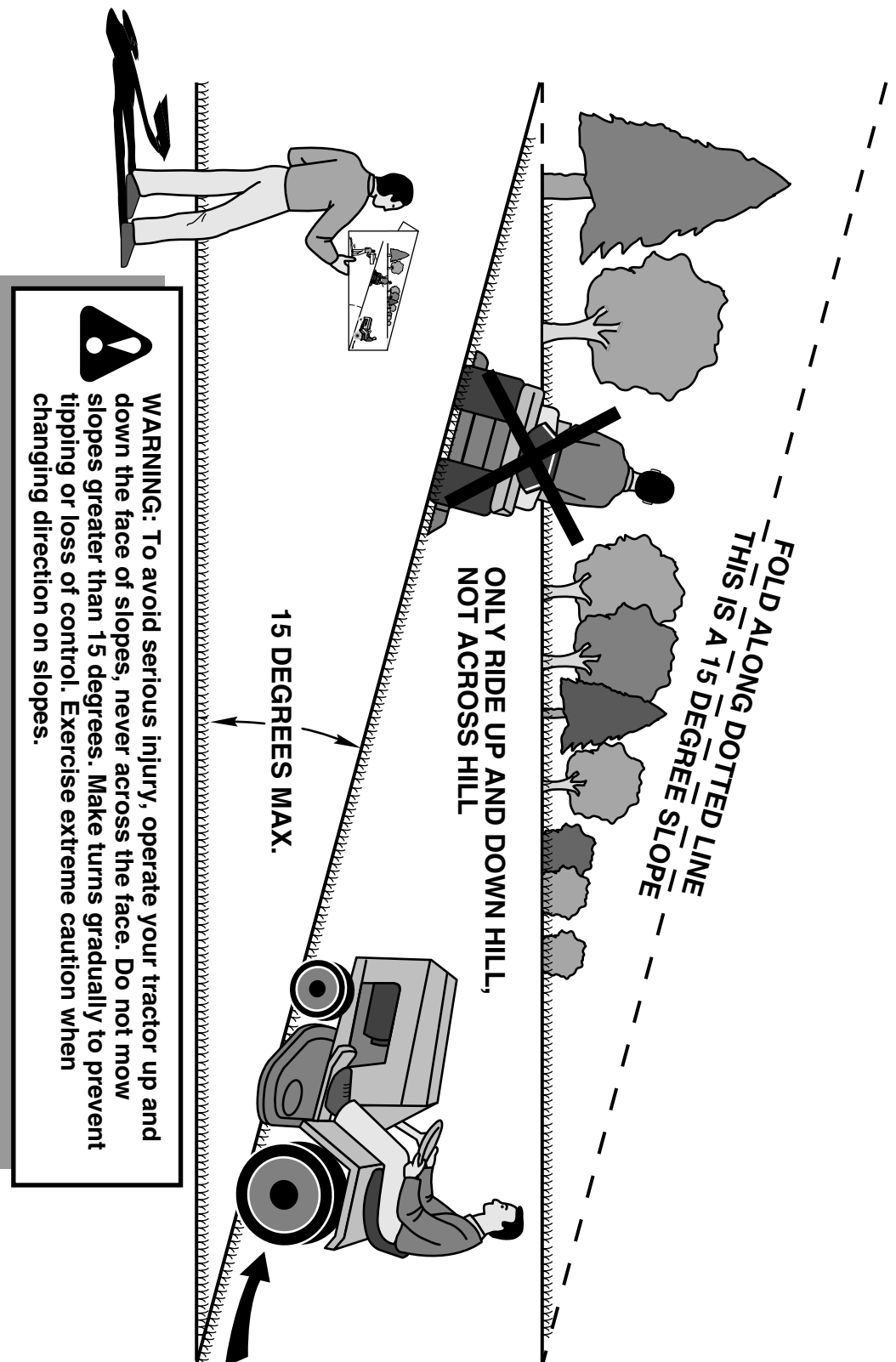

1. Fold this page along dotted line indicated above.
2. Hold page before you so that its left edge is vertically parallel to a tree trunk or other upright structure.
3. Sight across the fold in the direction of hill slope you want to measure.
4. Compare the angle of the fold with the slope of the hill.

SERVICE NOTES
