

ILLUSTRATED PARTS LIST

MODEL NO. 96051002701

CUSTOMER CATALOG NO. CTH 174

PRODUCT NO. 960 51 00-27

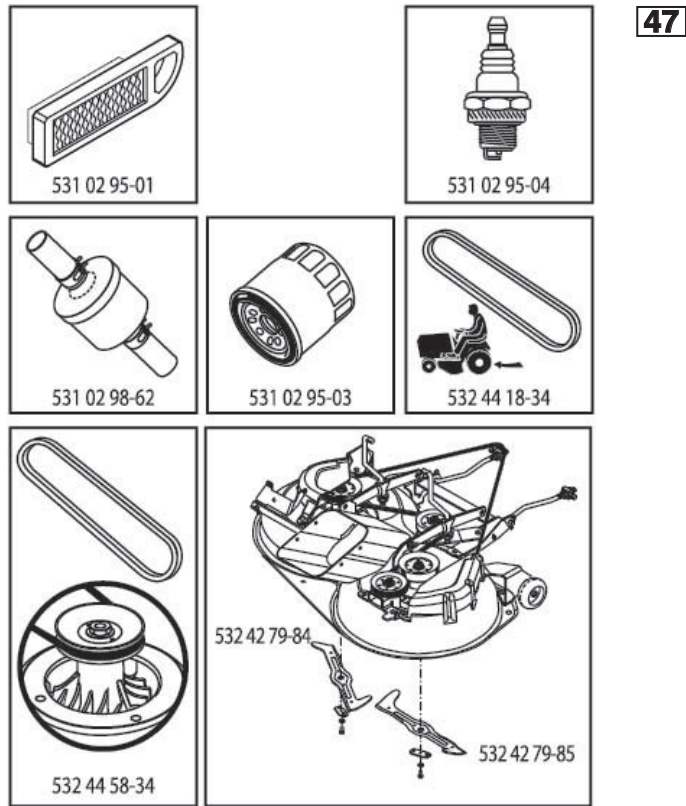

447026

TRACTOR - MODEL NO. CTH 174 (96051002701), PRODUCT NO. 960 51 00-27
DECALS 27

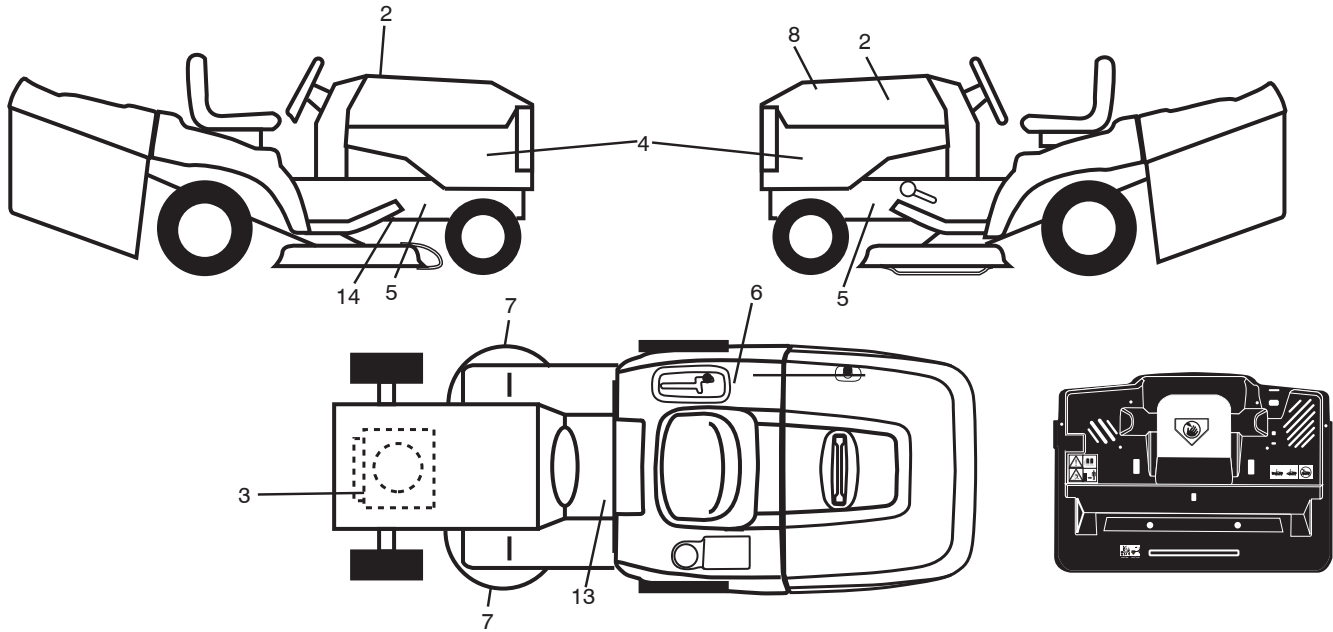

KEY NO.	PART NO.	DESCRIPTION
2	581 62 73-01	Decal, Hood Emblem
3	581 57 97-01	Decal, Warning Eng. Symbols
4	532 44 77-72	Decal, Hood Panel
5	581 57 96-01	Decal, Chassis Hot Muffler
6	581 72 41-01	Decal, Fender 100 DB/CE
7	581 57 91-01	Decal, Cutfinger CE
8	532 44 70-26	Decal, Rpl.
13	581 57 83-01	Decal, Warning
14	532 44 11-89	Decal, Deck Belt Sch.
--	581 72 48-01	Decal, Bypass

KEY NO.	PART NO.	DESCRIPTION
--	532 44 32-61	Decal, Inst. Mulch
--	532 18 04-35	Decal, Backplate Symb.
--	532 44 27-44	Decal, Battery Door
--	532 44 14-09	Pad, Footrest, LH
--	532 44 14-10	Pad, Footrest, RH
--	115 56 26-20	Manual Oper. Euro
--	115 56 27-10	Manual Oper. Scand
--	115 56 28-50	Manual Oper. E-Bloc
--	115 56 29-40	Manual Oper. Baltic

WHEELS AND TIRES

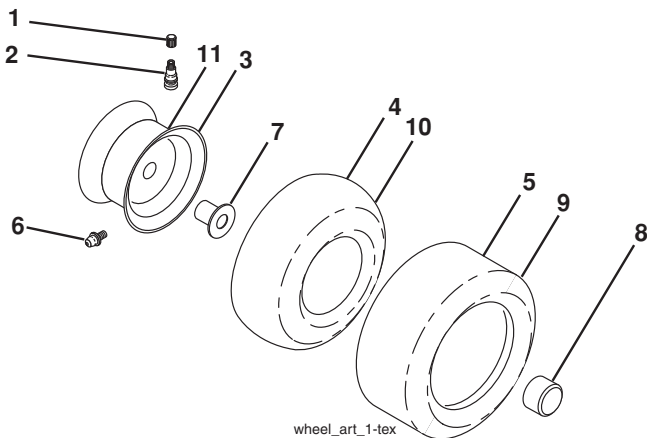

KEY NO.	PART NO.	DESCRIPTION
1	532 05 91-92	Cap Valve Tire
2	532 06 51-39	Stem Valve
3	532 13 83-36	Rim Asm. 6" Front
4	532 05 99-04	Tube Front (Service Item Only)
5	532 10 62-22	Tire F T 15 x 6 0 - 6
6	532 12 49-57	Fitting Grease (Front Wheel Only)
7	532 12 49-59	Bearing Flange (Front Wheel Only)
8	532 17 50-39	Cap Axle Blk. 1 50 x 1 00
9	532 42 05-31	Tire R 18 x 9.5-8 Turf Saver LT
10	532 12 49-26	Tube Rear (Service Item Only)
11	532 13 83-37	Rim Asm. 8" Rear
--	532 14 43-34	Sealant, Tire (10 oz. Tube)

NOTE: All component dimensions given in U.S. inches
 1 inch = 25.4 mm

TRACTOR - MODEL NO. CTH 174 (96051002701), PRODUCT NO. 960 51 00-27

SCHMATIC **38**

SCH19

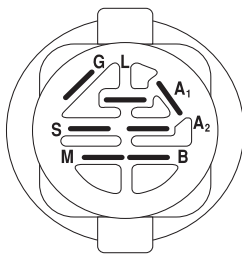
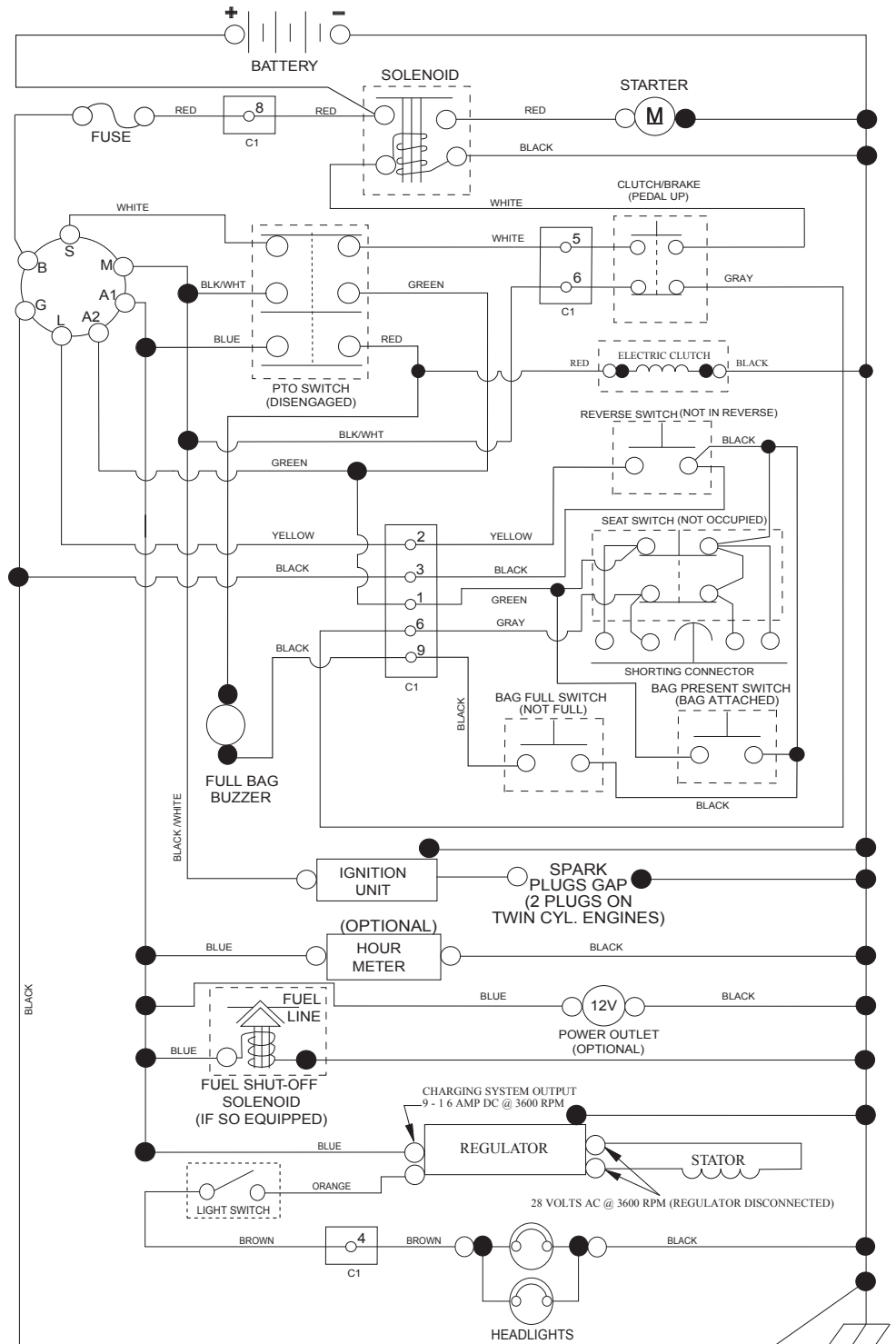

IGNITION SWITCH

POSITION	CIRCUIT	"MAKE"
OFF	M+G+A1	
RUN/OVERRIDE	B+A1	
RUN	B+A1	L+A2
START	B + S + A1	



CHASSIS HARNESS CONNECTOR (C1) (MATING SIDE)

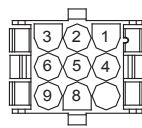

DASH HARNESS CONNECTOR (C1) (MATING SIDE)

WIRING INSULATED CLIPS
NOTE: IF WIRING INSULATED CLIPS WERE REMOVED FOR SERVICING OF UNIT, THEY SHOULD BE RE-INSTALLED TO PROPERLY SECURE YOUR WIRING.

 NON-REMOVABLE CONNECTIONS

 REMOVABLE CONNECTIONS

TRACTOR - MODEL NO. CTH 174 (96051002701), PRODUCT NO. 960 51 00-27
ELECTRICAL **32**

TC06S

With Service Minder Option

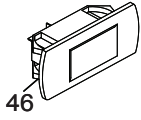

46

With Charge Indicator Option

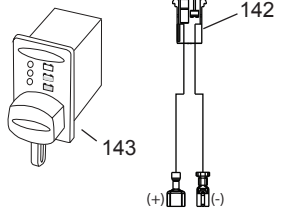

(+) (-)

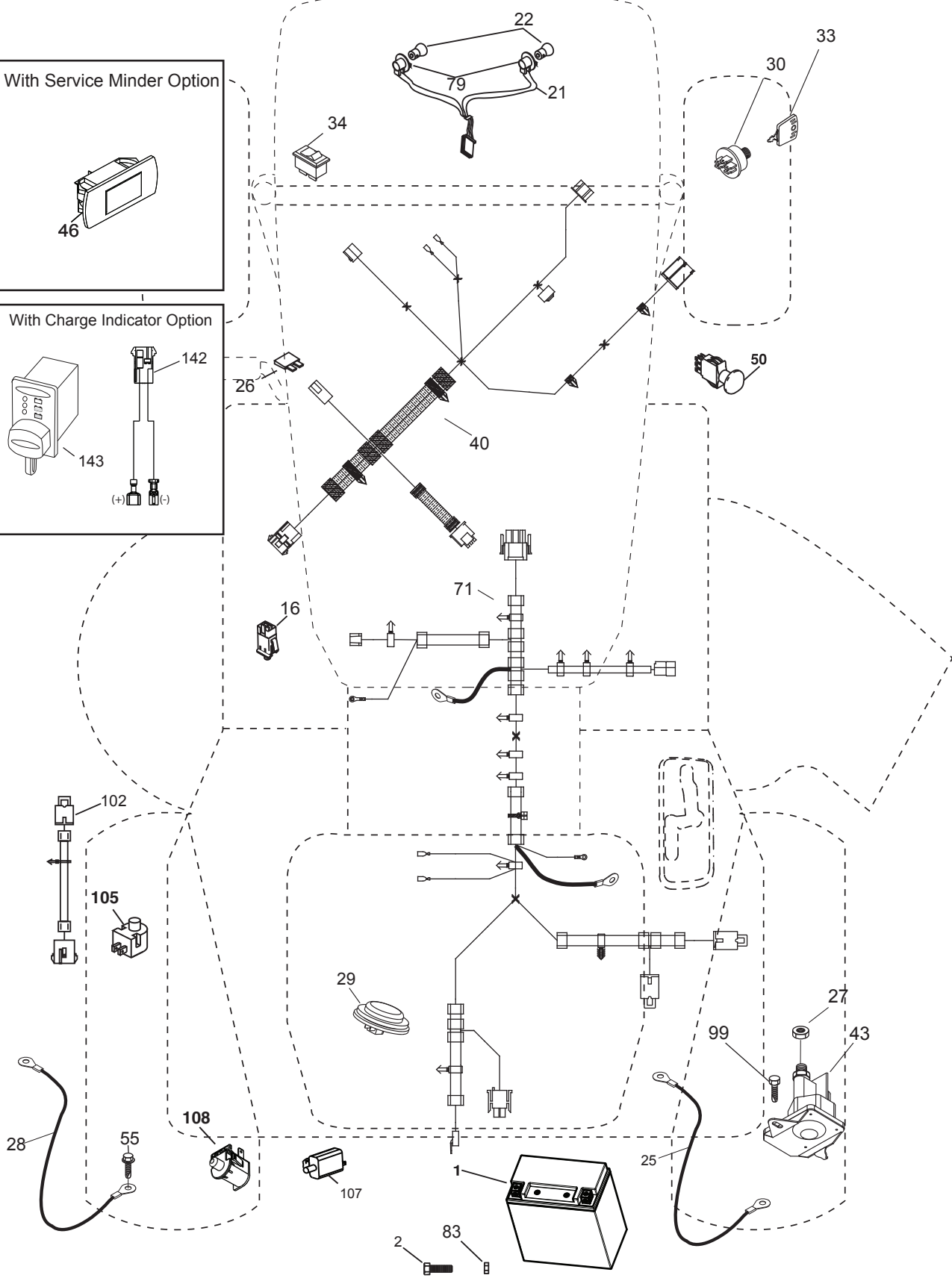

**TRACTOR - MODEL NO. CTH 174 (96051002701), PRODUCT NO. 960 51 00-27
ELECTRICAL 32**

KEY NO.	PART NO.	DESCRIPTION
1	532 43 71-57	Battery
2	532 44 09-23	Screw Hex Head Cap M6 x 1.12 mm
16	532 17 61-38	Switch Interlock Push-In
21	532 40 02-52	Harness Socket Light w/4152J
22	532 00 41-52	Bulb Light
25	581 48 98-01	Cable Starter
26	532 17 51-58	Fuse
27	873 51 04-00	Nut Keps Hex 1/4-20 unc
28	581 48 98-02	Cable, Ground
29	532 40 15-45	Switch, Seat
30	532 19 33-50	Switch, Ign.
33	532 41 19-35	Key/Chain
34	532 11 07-12	Switch Light/Reset
40	532 42 95-33	Harness Dash
43	532 19 25-07	Solenoid
50	532 17 46-51	Switch PTO
55	817 06 05-12	Screw Thdrol. 5/16-18 x 3/4 TYTT
71	532 44 08-20	Harness Chassis
79	532 17 52-42	Socket Asm. Bulb Twistlock
83	532 43 67-74	Nut Square M6 x 1.8.5 x 11 mm
99	817 72 04-08	Screw 1/4-20 x 1/2
102	532 44 12-62	Harness Pigtail Tex ROS Tuff Torq
105	532 40 75-68	Switch Reverse
107	532 18 03-79	Switch Full Bagger Indicator
108	532 42 10-62	Switch Snapmount

NOTE: All component dimensions given in U.S. inches
1 inch = 25.4 mm

TRACTOR - MODEL NO. CTH 174 (96051002701), PRODUCT NO. 960 51 00-27
CHASSIS AND ENCLOSURES 39

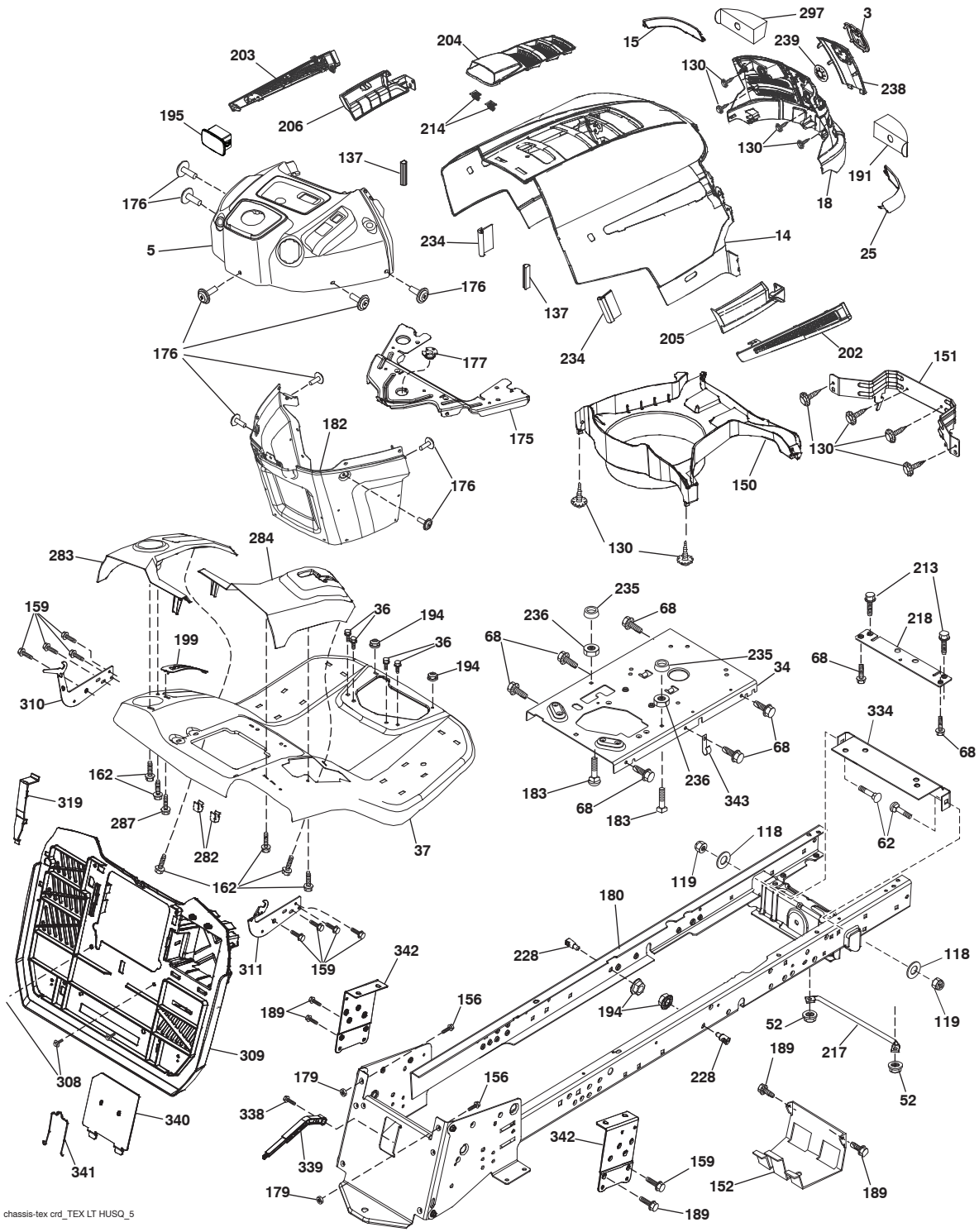

chassis-tex crd_TEX LT HUSQ_5

**TRACTOR - MODEL NO. CTH 174 (96051002701), PRODUCT NO. 960 51 00-27
CHASSIS AND ENCLOSURES **39****

KEY NO.	PART NO.	DESCRIPTION	KEY NO.	PART NO.	DESCRIPTION
3	581 05 63-01	Logo	203	532 44 13-43	Vent Side Hood LH
5	532 43 89-66	Dash	204	532 44 13-75	Vent Top Hood
14	532 44 12-67	Hood	205	532 44 13-44	Skirt Side RH
15	532 44 14-28	Lens LH	206	532 44 13-45	Skirt Side LH
18	532 44 13-68	Grille	213	874 76 05-12	Bolt Hex HD 5/16-18 unc 3/4
25	532 44 14-27	Lens RH	214	532 19 91-45	Clip Retainer
34	580 91 09-01	Plate Engine	217	532 40 91-67	Rod Pivot Hood
36	817 06 05-12	Screw 5/16-18 x 3/4	218	532 19 63-95	X-Piece Hood Stop
37	532 44 14-19	Fender	228	532 19 51-61	Stud Fastener
52	873 68 05-00	Nut Crownlock 5/16-18	234	532 40 47-42	Bumper Hood
62	872 11 06-08	Bolt 3/8-16 x 1	235	532 40 61-29	Spacer Fender
68	817 49 05-08	Screw Thdrol. 5/16-18 x 1/2	236	873 93 05 00	Nut Center Lock 5/16-18 unc
118	819 13 13-16	Washer 13/32 x 13/16 x 16	238	532 44 13-74	Trim
119	873 68 06-00	Nut 3/8-16	239	532 40 48-83	Clip Tinnerman
130	532 41 63-58	Screw #10 x .750 BOS Thread	282	532 41 41-10	Clip Retainer
137	532 40 75-90	Bumper Dash	283	532 44 05-31	Console Deck Lift
150	532 40 75-37	Air Duct	284	532 44 05-30	Console Shift RH
151	532 40 78-07	Bracket Pivot	287	817 60 04-06	Screw Hex Washhead. 1/4-20 x 3/8
152	532 19 95-35	Shield Browning	297	532 40 66-65	Insert Reflective LH
156	872 14 06-14	Bolt 3/8-16 unc x 1-3/4	308	532 17 18-77	Bolt 5/16-18 unc x 3/4
159	817 00 06-12	Screw 3/8-16 x 3/4	309	584 44 11-01	Backplate
162	532 14 24-32	Screw Hex Wsh. Hi-Lo 1/4 x 1/2 unc	310	532 44 66-36	Bracket Hangbar Bag LH
175	532 19 94-72	Crossmember	311	532 44 66-37	Bracket Hangbar Bag RH
176	532 40 07-76	Screw 10-24 x 5/8	319	532 17 46-62	Bracket Actuator Bagger
177	532 19 52-28	Bushing Steering	334	532 44 25-37	Bracket Engine
179	532 16 89-37	Nut Push	338	532 43 66-40	Bolt Shoulder
180	581 18 71-01	Chassis	339	532 43 66-41	Lever Bagger Full
182	532 40 71-76	Dash Lower	340	532 44 09-31	Door Battery Tray
183	874 52 05-20	Bolt 5/16-18 x 1-1/4	341	532 43 66-38	Latch Batter Tray
189	817 00 05-12	Screw 5/16-18 x 3/4	342	532 43 59-38	Support Fender
191	532 41 65-01	Insert Reflective RH	343	532 44 07-49	Clip
194	873 90 05-00	Nut Lock Hex Flange 5/16-18			
195	532 43 99-76	Plug Dash			
199	532 41 87-39	Plate Deck Lift			
202	532 44 13-42	Vent Side Hood RH			

NOTE: All component dimensions given in U.S. inches
1 inch = 25.4 mm

TRACTOR - MODEL NO. CTH 174 (96051002701), PRODUCT NO. 960 51 00-27
DRIVE **40**

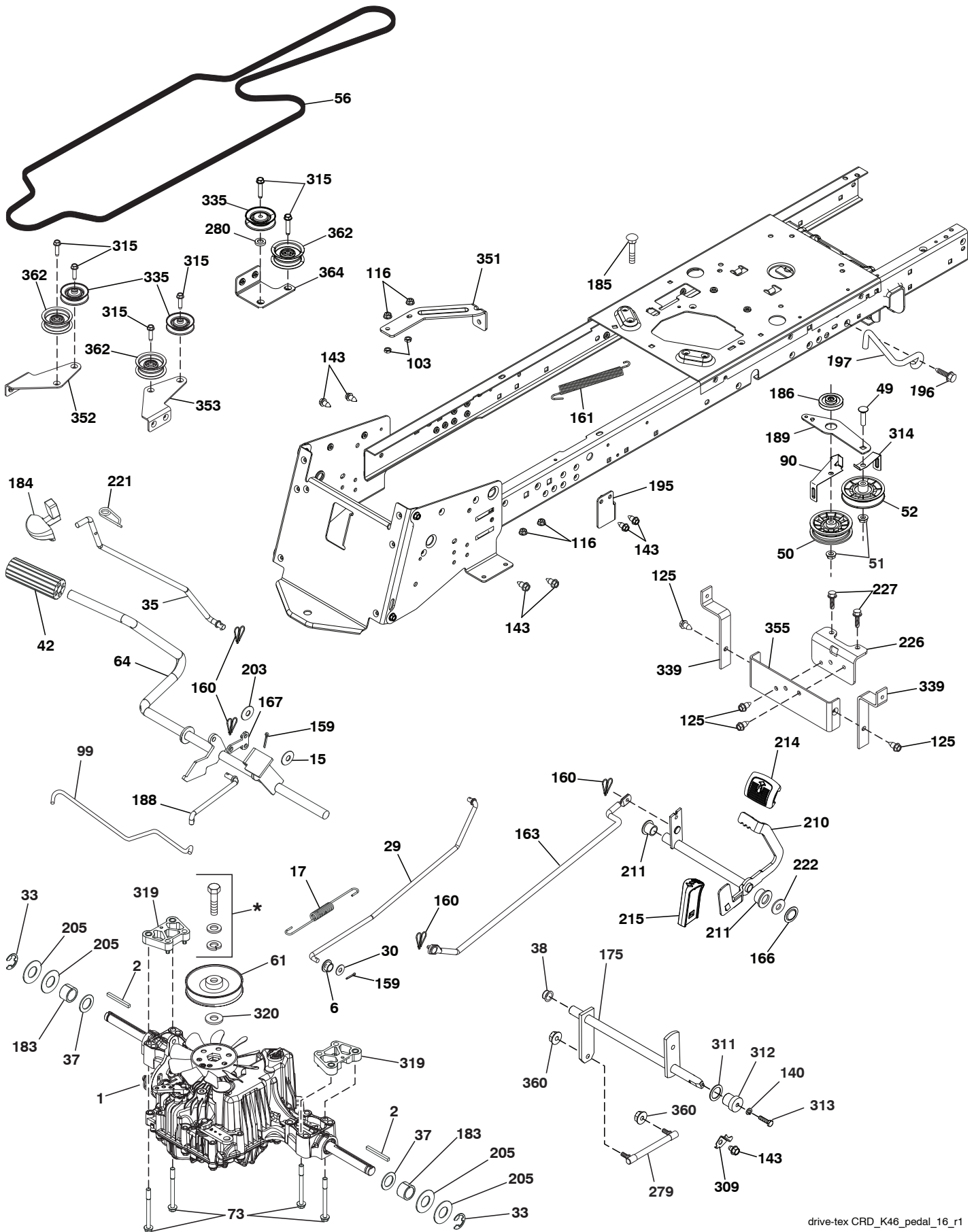

**TRACTOR - MODEL NO. CTH 174 (96051002701), PRODUCT NO. 960 51 00-27
DRIVE **40****

KEY NO.	PART NO.	DESCRIPTION	KEY NO.	PART NO.	DESCRIPTION
1	---	Transaxle, TUFFTORQ K46 DF (446488) (Order parts from trans-axle manufacturer.)	189	532 43 36-11	Bellcrank Ground Drive
2	532 12 35-83	Key Square	195	580 45 69-01	Bracket Brake Rod
6	532 12 40-28	Bushing Snap	196	817 00 06-16	Screw 3/8-16 x 1
15	819 13 13-16	Washer 13/32 x 13/16 x 16 Ga.	197	585 65 86-01	Link Clutch
17	532 43 62-27	Spring, Brake	203	819 11 11-16	Washer 11/32 x 11/16 x 16 Ga.
29	532 43 58-81	Rod, Brake	205	532 12 17-48	Washer 25/32 x 1-5/8 16 Ga.
30	819 13 16-16	Washer 13/32 x 1 x 16 Ga.	210	532 40 09-80	Rocker Asm. Pedal
33	812 00 00-01	Ring E	214	532 42 12-63	Pedal Forward
35	532 40 10-31	Rod, Brake, Park	215	532 41 94-82	Pad Pedal Reverse
37	532 18 89-67	Washer .793 x 1.637 x 060	211	532 12 01-83	Bearing Nylon
38	532 16 96-13	Nylon Snap In	221	532 40 31-87	Retainer Spring
42	532 12 48-72	Cover, Foot Pedal	222	879 21 20-10	Washer Flat
49	872 11 06-14	Bolt 3/8-16 unc	226	532 40 15-64	Bracket Mount Torque
50	532 19 43-27	Idler Flat	227	817 49 05-12	Screw
51	873 90 06-00	Lock Nut 3/8-16	279	532 44 42-83	Link Shift Hydro
52	532 19 43-26	Idler V-Groove	280	819 11 10-12	Washer 11/32 x 5/8 x 12 Ga.
56	532 44 18-34	V-Belt, Drive	309	532 16 55-81	Plate Fstnr.
61	532 43 77-88	Pulley Transaxle	311	532 16 98-45	Washer Nylon
64	532 19 78-65	Shaft Asm. Pedal Brake Control	312	532 16 56-14	Hub Tapered
73	874 49 05-56	Bolt Hex 5/16-18 x 3.75	313	874 78 04-16	Bolt Hex Fin 1/4-20 unc x 1.GD5
90	532 44 36-05	Keeper Belt Clutching	314	532 44 47-13	Retainer, Belt
99	532 44 39-47	Rod Bypass	315	817 58 05-20	Screw Thdrol 5/16-18 x 4.25
103	873 35 05-00	Nut 5/16-18 unc	319	532 43 67-94	Spacer Transaxle Tex CRD
116	873 90 05-00	Nut Lock Hex Flange 5/16-18	320	532 18 76-90	Washer Spacer
125	817 00 05-12	Screw 5/16-18 x 3/4	335	532 19 95-34	Pulley V Idler Ground Drive
140	810 04 04-00	Washer Lock Hvy. Helical 1/4	339	532 43 68-67	Strap Torue K46 CRD Tex
143	817 49 05-08	Screw Thdrol 5/16-18 x 1/2 TYTT	351	532 43 69-98	Bracket Deck Sway
159	876 02 04-12	Pin Cotter 1/8 x 3/4	352	532 43 58-19	Bracket Idler
160	532 16 94-84	Retainer Clip	353	532 43 65-77	Bracket Idler RH
161	532 10 57-09	Spring, Return, Clutch	355	532 43 56-69	Strap Torque
163	532 43 66-32	Rod Control	360	532 44 47-14	Nut Hex 5/16-24
166	532 42 91-64	Nut Push .625	362	532 43 68-12	Idler Flat
167	532 40 52-57	Latch Brake Parking	364	532 44 30-32	Bracket Idler
175	532 42 93-59	Shaft Asm. Cross Shift			
183	532 13 70-57	Spacer Axle			
184	532 44 14-07	Handle Park Brk.			
185	872 11 06-22	Bolt 3/8-16 unc x 2-3/4			
186	532 19 43-21	Spacer Retainer			
188	532 19 43-23	Link Clutch Ground Drive			

* Parts supplied by manufacturer

NOTE: All component dimensions given in U.S. inches
1 inch = 25.4 mm

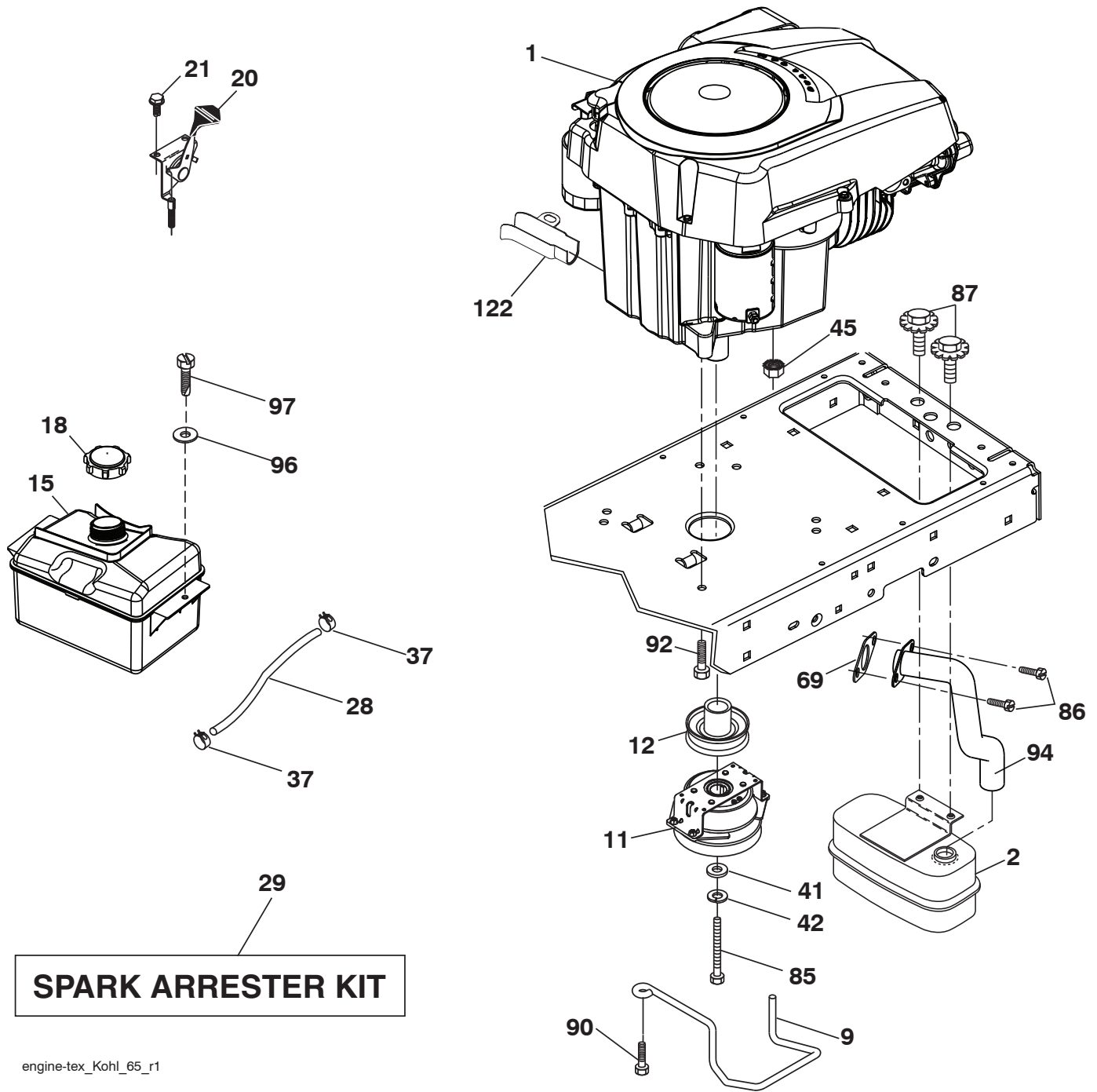

**TRACTOR - MODEL NO. CTH 174 (96051002701), PRODUCT NO. 960 51 00-27
ENGINE 24**

KEY NO.	PART NO.	DESCRIPTION
1	-----	Engine Kohler Model No. SV530-3212 (438331)(Order parts from engine manufacturer.)
2	580 53 23-01	Muffler
9	532 19 43-20	Keeper Belt Engine
11	587 24 16-01	Clutch Electric
12	532 40 50-97	Pulley Engine
15	581 28 99-01	Tank Fuel
18	532 43 02-20	Cap Asm Fuel
20	532 18 38-97	Control Throttle/Ch Flag
21	532 41 63-58	Screw #10 x 0.750 BOS Thread
28	532 13 70-40	Fuel Line 20"
29	532 13 71-80	Spark Arrester Kit
37	532 12 34-87	Clamp Hose Black
41	532 12 61-97	Washer 1-1/2 OD x 15/32 ID x .250
42	810 04 07-00	Lock Washer 7/16
45	873 51 04-00	Nut Keps 1/4-20 unc
69	532 18 59-09	Gasket
85	532 17 99-53	Bolt Hex 7/16-20 x 3.75.
86	532 19 23-34	Screw, Socket HD 5/16-18 x .75
87	532 17 18-77	Bolt 5/16-18 x 3/4
90	817 00 06-16	Screw 3/8-16 x 1
92	817 12 06-16	Screw 3/8-16 x 1
94	532 18 86-54	Tube Exhaust
96	819 09 14-16	Washer 9/32 x 7/8 x 16 Ga.
97	817 67 04-12	Screw Hexwsh Thdrol 1/4-20 x 3/4
122	532 42 19-22	Extension Drain Oil

NOTE: All component dimensions given in U.S. inches
1 inch = 25.4 mm

TRACTOR - MODEL NO. CTH 174 (96051002701), PRODUCT NO. 960 51 00-27
STEERING ASSEMBLY [41]

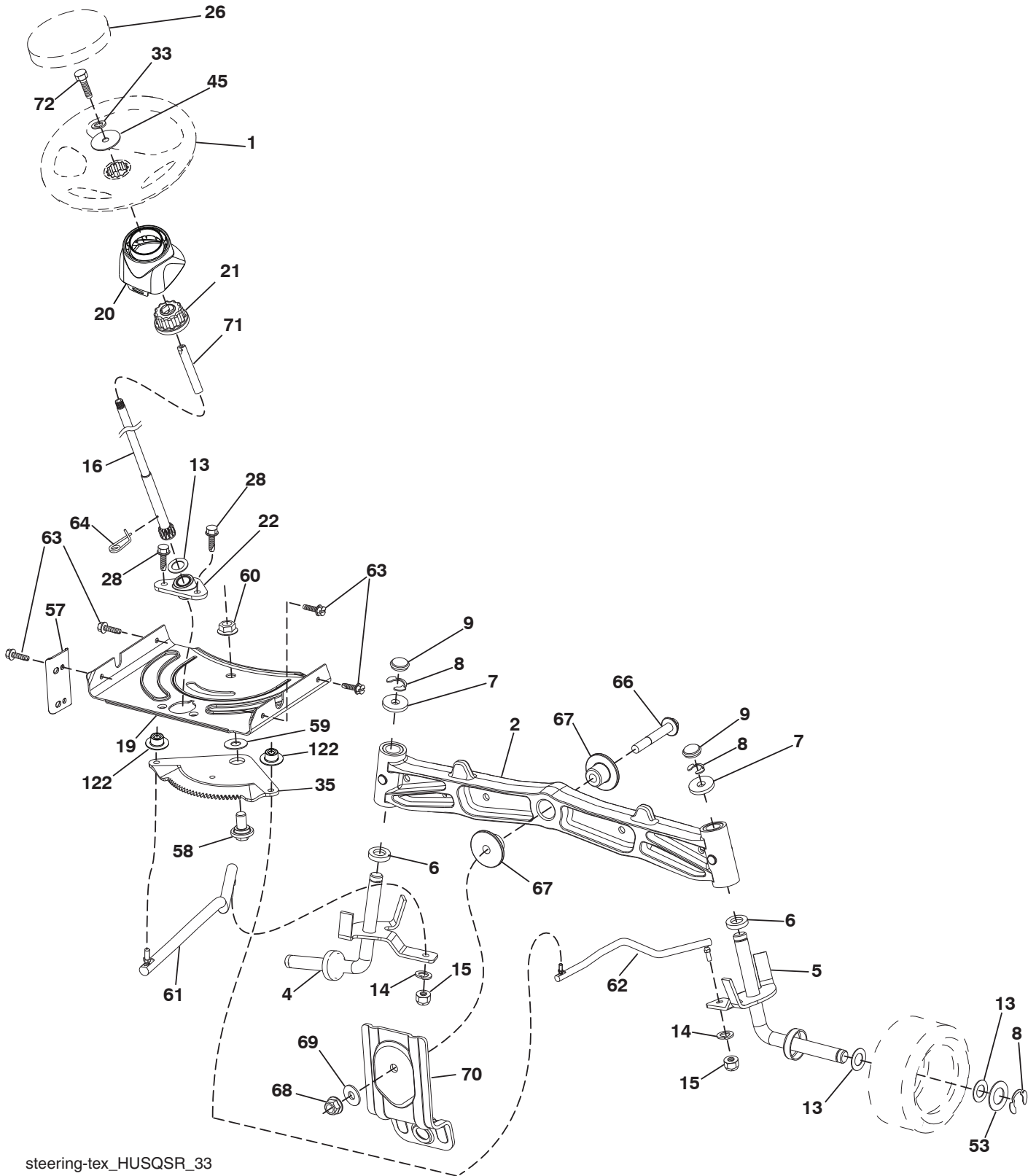

steering-tex_HUSQSR_33

**TRACTOR - MODEL NO. CTH 174 (96051002701), PRODUCT NO. 960 51 00-27
STEERING ASSEMBLY 41**

KEY NO.	PART NO.	DESCRIPTION
1	532 43 97-40	Wheel, Steering Husq SR
2	532 19 59-68	Axle Asm., Front
4	532 40 30-87	Spindle Asm., LH
5	532 40 30-88	Spindle Asm., RH
6	532 12 49-31	Bearing, Race Thrust Hardened
7	532 12 17-48	Washer 25/32 x 1-5/8 x 16 Ga.
8	812 00 00-29	Ring, Clip #T5304-75
9	532 12 12-32	Cap, Spindle
13	532 12 17-49	Washer 25/32 x 1-1/4 x 16 Ga.
14	810 04 06-00	Washer, Lock Hvy. Hlcl. Spr. 3/8
15	873 54 06-00	Nut, Crown Lock 3/8-24 unf
16	532 42 93-73	Shaft Steering
19	532 19 47-29	Plate Steering
20	532 44 14-25	Boot, Steering
21	532 18 67-37	Adapter, Wheel Steering
22	532 42 05-37	Supt., Strg. Lower
26	532 43 97-43	Insert, Wheel Steering Husq SR
28	817 00 06-12	Screw 3/8-16 x 3/4
33	810 04 05-00	Washer Lock 5/16
35	532 19 47-32	Gear, Sector Plate
45	819 11 38-12	Washer 11/32 x 3/8 x 12 Ga.
53	532 18 89-67	Washer Hardened .793 x 1.637 x .060
57	532 40 74-65	Bracket Upstop
58	532 19 47-47	Bolt Shoulder Sector Pivot CFM
59	532 19 47-48	Washer Thrust Sector Steering
60	873 97 10-00	Nut Flange Lock 5/8-11
61	532 19 47-40	Draglink, LH
62	532 19 47-41	Draglink, RH
63	817 00 05-12	Screw 5/16-18 x 3/4
64	532 19 98-49	Retainer Clip Spring Steering
66	871 02 07-48	Bolt Hex Fghd. 7/16-14 x 3 Serr.
67	532 19 47-37	Bushing PM Front Axle
68	873 90 07-00	Nut Lock Flange 7/16-14 Gr. 5
69	532 19 91-62	Washer 1.5 x .505 x .118
70	532 19 61-97	Bracket Deck Susp. Front
71	532 19 07-52	Shaft Extension Steering
72	532 42 89-82	Bolt Fin Hx 5/16-18 x 4 w/Patch
122	532 44 49-62	Cap Gear

NOTE: All component dimensions given in U.S. inches
1 inch = 25.4 mm

TRACTOR - MODEL NO. CTH 174 (96051002701), PRODUCT NO. 960 51 00-27
MOWER DECK **44**

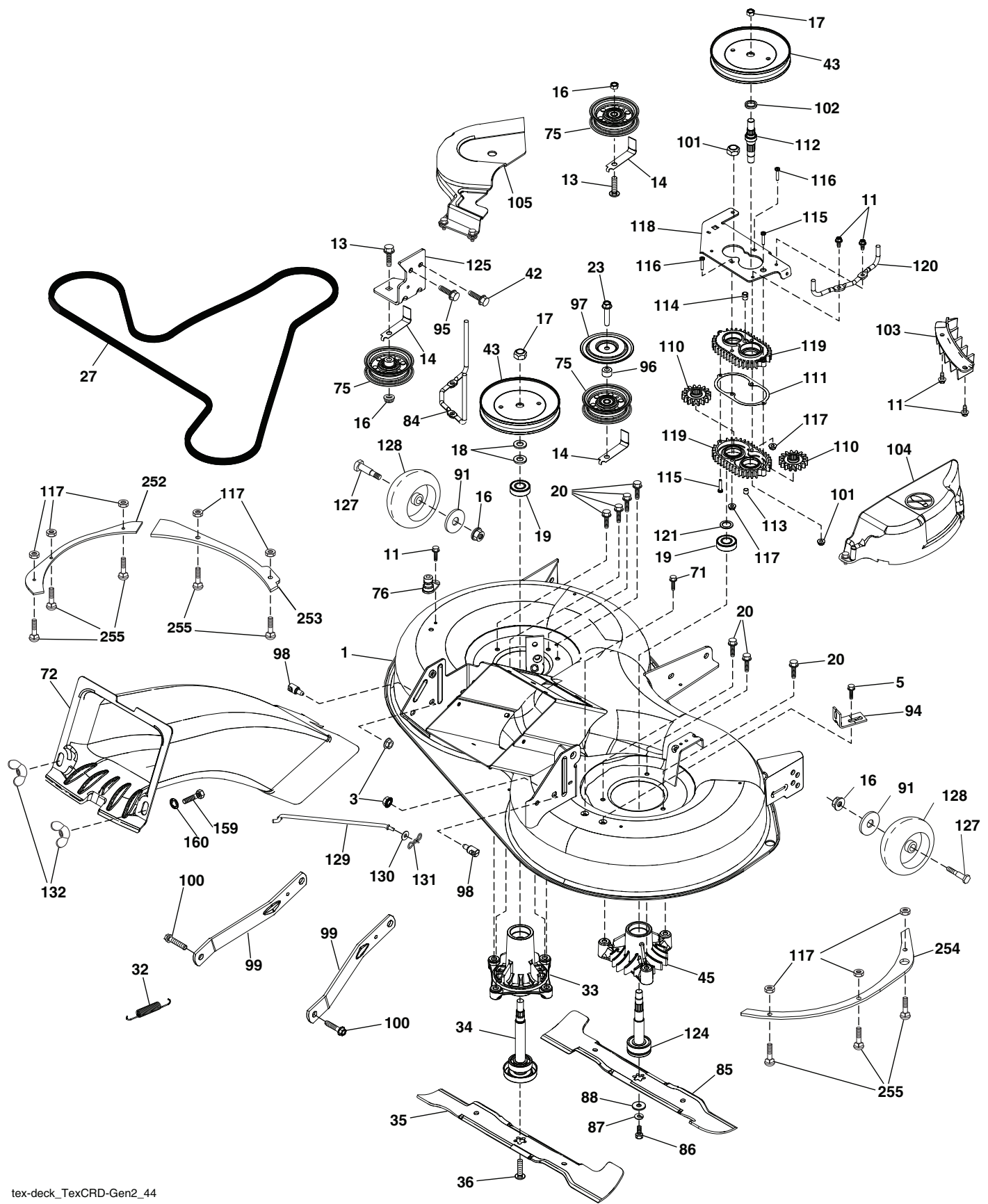

tex-deck_TexCRD-Gen2_44

**TRACTOR - MODEL NO. CTH 174 (96051002701), PRODUCT NO. 960 51 00-27
MOWER DECK 44**

KEY NO.	PART NO.	DESCRIPTION	KEY NO.	PART NO.	DESCRIPTION
1	584 40 21-01	Deck Weldment	105	532 44 14-78	Mandrel Cover LH
3	873 90 05-00	Nut Lock Hex Flange 5/16 - 18	110	532 41 53-56	Gear Output
5	817 00 05-10	Bolt 5/16-18	111	532 43 69-79	Gasket Gearcase
11	532 13 77-29	Screw Thd Roll 1/4 - 20 X 5/8	112	532 44 38-52	Shaft Gearcase
13	872 11 06-12	Bolt Carr Sh 3/8 - 16 X 1 - 1/2 Gr. 5	113	532 43 85-33	Plug Oil
14	532 15 60-85	Keeper Belt Idler	114	532 43 85-34	Valve Relief
16	873 90 06-00	Nut Lock FIG 3/8 - 16 unc	115	818 03 10-16	Screw Torx #10-24 x 1
17	532 40 02-34	Nut Flange Lock Top	116	872 11 04-14	Bolt 1/4-20 x 1.75 Gr. 5
18	532 18 76-90	Washer Spacer Mandrel	117	873 90 04-00	Nut Hex Flange 1/4-20 unc
19	532 11 04-85	Bearing Ball Mandrel	118	532 43 69-89	Arm Clutching
20	532 17 39-84	Screw Thread Roll	119	532 43 81-66	Gearcase Subasm
23	817 49 06-28	Screw Thdrol 3/8 - 16 X 1-3/4	120	532 43 69-91	Keeper Belt RH
27	532 44 58-34	V-Belt Drive	121	532 43 69-85	Washer
32	532 44 62-05	Spring Drive Deck	124	532 43 69-86	Non Greasable Mandrel Shaft
33	532 18 72-81	Housing Mandrel 4pt Service	125	532 43 69-94	Bracket Idler Chasses
34	532 19 28-72	Shaft Asm Mndrl N/Greaseable38	127	532 19 34-06	Bolt Shoulder 3/8-16 x 3-5/8 Gr. 5
35	532 42 79-84	Blade Mower LH	128	532 17 48-73	Wheel Guage
36	532 19 30-03	Bolt/Washer Asm 7/16 - 20 unf	129	532 40 48-51	Rod Anti-Sway
42	817 00 05-12	Screw 5/16-18 x 3/4	130	819 13 13-12	Washer 13/32 x 13/16 x 12 Ga.
43	532 19 97-89	Pulley Mandrel	131	532 19 42-08	Pin Cotter 5/16 Bow Tie Lock
45	532 13 71-52	Housing Mandrel	132	532 17 88-99	Knob Handle
71	817 67 06-08	Screw Thdrol 3/8-16 x 1/2	159	872 14 06-14	Bolt 3/8-16 unc-1-3/4
72	532 44 68-10	Chute Upper	160	532 16 89-37	Nut Push
75	532 13 14-94	Pulley Idler Flat	252	581 55 44-02	Plate Left Bolt
76	532 41 55-98	Washout Port	253	581 55 45-02	Plate LH Side Bolt
84	532 40 01-40	Keeper Belt LH Mandrel	254	581 55 47-02	Plate RH Side Bolt
85	532 42 79-85	Blade Mower RH	255	539 10 98-00	Carriage Bolt
86	532 18 17-13	Bolt 3/8-24 x 1.50 Gr. 8	--	532 19 28-70	Mandrel Assembly (Includes Housing (key #33), Shaft Assembly (key #34), and Bearing Only - Pulley/Nut/Washer and Blade Bolt/Washers Not Included)
87	810 03 06-00	Washer Lock Hvy 3/8			Replacement Mower Complete
88	532 14 02-96	Washer Hard Blade Mower Vented			
91	819 13 20-12	Washer 13/32 x 1-1/4 x 12 Ga.			
94	532 19 72-50	Bracket Clutch Cable			
95	817 00 06-12	Screw 3/8-16 x 3/4	--	532 44 85-40	
96	532 40 02-71	Spacer			
97	532 18 20-61	Shield Idler Mower			
98	532 19 51-61	Stud Fastener			
99	532 19 51-86	Arm Suspension Mower Rear			
100	532 19 65-39	Bolt Shoulder			
101	873 68 09-00	Nut Crownlock 9/16 - 18 unc			
102	532 40 25-11	Spacer Bearing Swing Plate			
103	532 43 69-92	Guard Front Vent			
104	532 44 14-79	Mandrel Cover RH			

NOTE: All component dimensions given in U.S. inches
1 inch = 25.4 mm

TRACTOR - MODEL NO. CTH 174 (96051002701), PRODUCT NO. 960 51 00-27
MOWER LIFT 45

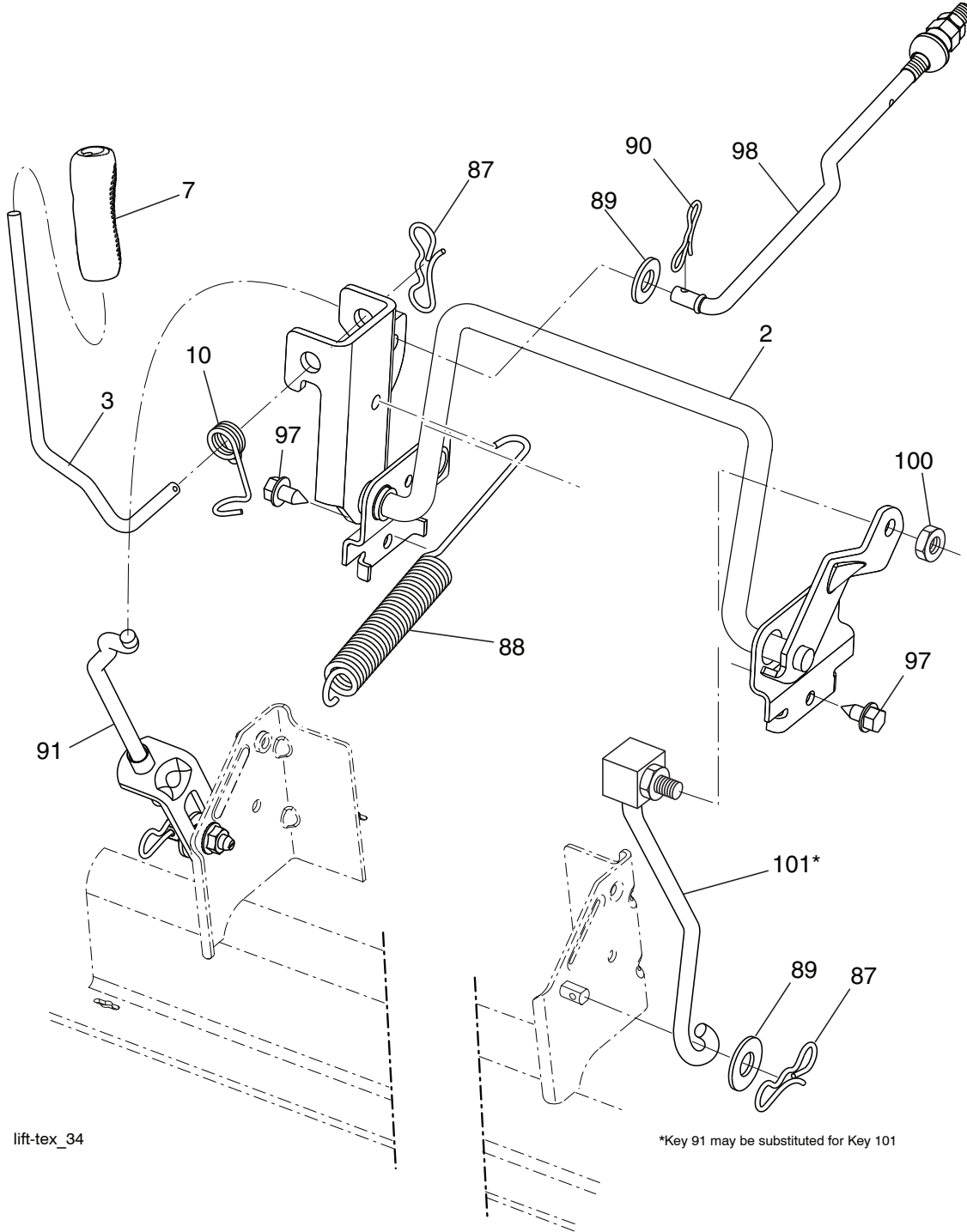

lift-tex_34

*Key 91 may be substituted for Key 101

KEY NO.	PART NO.	DESCRIPTION
2	532 43 69-96	Deck Lift Weldment
3	532 19 52-31	Lever Asm., Lift RH
7	580 96 23-01	Grip, Lever
10	532 19 63-14	Spring Torsion
87	532 19 42-09	Pin Cotter 7/16 Bow Tie Lock
88	532 43 69-95	Spring Lift Assist
89	819 19 19-12	Washer Clear Zinc
90	532 19 42-08	Pin Cotter 5/16 Bow Tie Lock

KEY NO.	PART NO.	DESCRIPTION
91	532 19 51-81	Link Lift Susp. Mower Rear
97	817 49 06-08	Screw 3/8-16 x 1/2
98	532 19 52-70	Link Lift Susp. Front Mower
100	873 93 06-00	Nut Centerlock 3/8-16
101	532 40-70-03	Link Asm. Lift FXD

NOTE: All component dimensions given in U.S. inches
 1 inch = 25.4 mm

TRACTOR - MODEL NO. CTH 174 (96051002701), PRODUCT NO. 960 51 00-27
SEAT ASSEMBLY 42

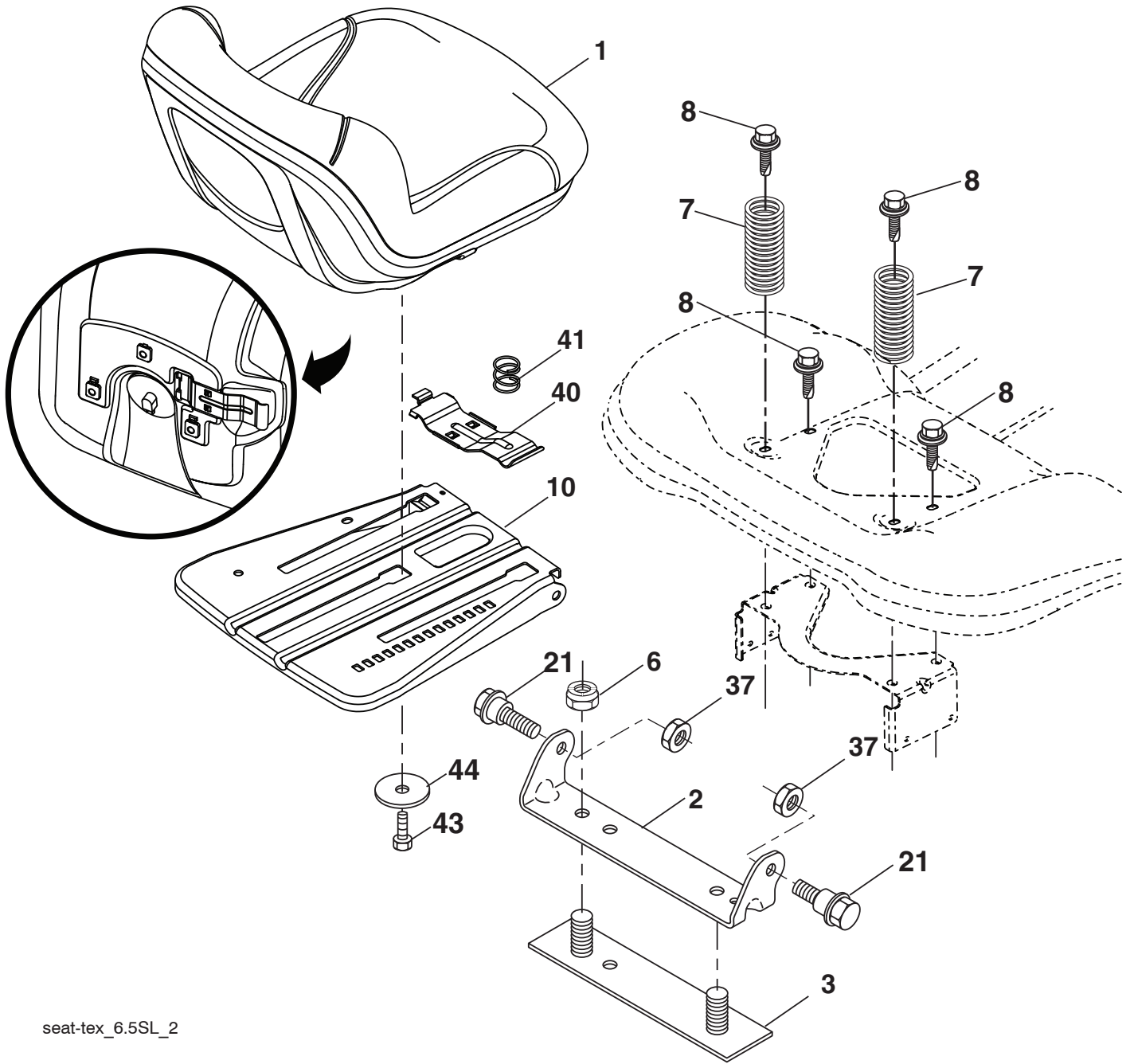

seat-tex_6.5SL_2

KEY NO.	PART NO.	DESCRIPTION
1	532 43 98-22	Seat
2	532 18 01-66	Bracket Pivot Fender
3	532 14 06-75	Strap, Asm. Fender
6	873 80 06-00	Nut, Lock w/Ins. 3/8-16 unc
7	532 12 41-81	Spring, Seat Cprsn.
8	532 17 18-77	Bolt 5/16-18 unc x 3/4 w/Sems.
10	532 19 69-77	Pan, Seat
21	532 17 18-52	Bolt, Shoulder 5/16-18

KEY NO.	PART NO.	DESCRIPTION
37	873 80 05-00	Nut, Lock 5/16-18 unc
40	532 19 76-61	Handle
41	532 19 82-00	Spring
43	874 76 06-12	Bolt 3/8-16 unc x 3/4
44	819 13 38-12	Washer 13/32 x 2-3/8 x 12 Ga.

NOTE: All component dimensions given in U.S. inches
 1 inch = 25.4 mm

TRACTOR - MODEL NO. CTH 174 (96051002701), PRODUCT NO. 960 51 00-27
BAGGER **46**

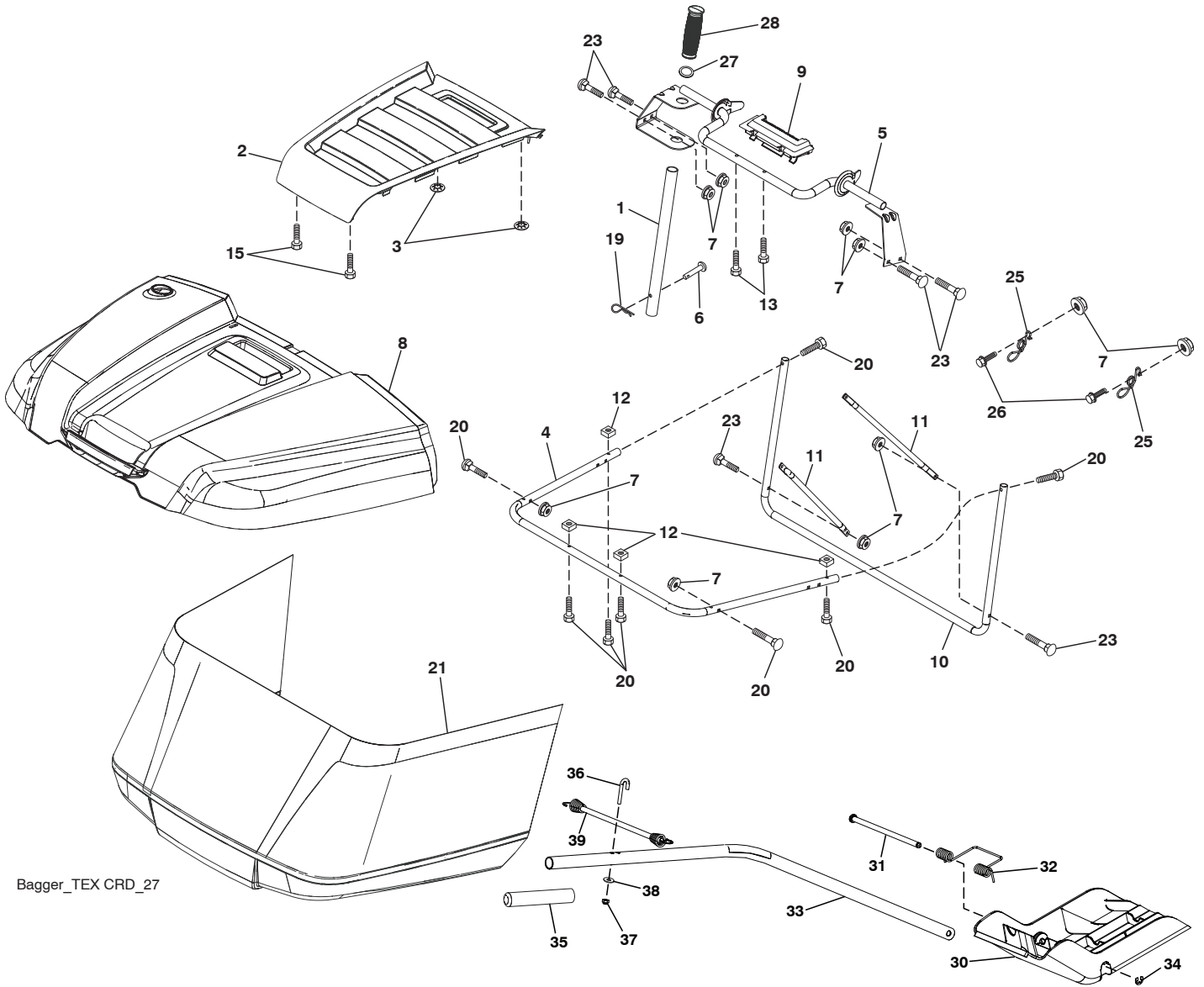

Bagger_TEX CRD_27

**TRACTOR - MODEL NO. CTH 174 (96051002701), PRODUCT NO. 960 51 00-27
BAGGER 46**

KEY NO.	PART NO.	DESCRIPTION
1	532 42 86-10	Tube Handle Bagger
2	532 44 13-58	Applique Top
3	532 41 38-08	Nut Push .156
4	532 43 96-12	Frame Asm Bagger Top
5	532 41 76-32	Frame Asm Top Bagger
6	532 12 68-75	Rivet Drilled
7	873 90 04-00	Nut Hex Flange 1/4-20 unc
8	532 44 12-61	Cover Bagger
9	532 41 76-29	Insert Handle Bagger
10	532 43 67-70	Frame Front
11	532 43 67-71	Tubing Brace Bagger
12	532 42 17-93	Nut Square 1/4
13	532 42 17-80	Screw 1/4 x 1.150
15	532 42 18-01	Screw #8 Flat Head
19	532 19 42-08	Cotter Pin 5/16 Bow Tie
20	585 36 88-01	Screw Hex Cap 1/4-20 x 1.375
21	532 44 83-06	Bag Asm
23	872 04 04-10	Bolt Carr. 1/4-20
25	532 42 16-14	Spring Latch
26	817 49 04-12	Screw 1/4-20 x 3/4
27	532 42 12-62	Grommet Rubber
28	532 16 57-87	Grip Handle Black
30	532 43 74-52	Plug
31	532 43 58-61	Pin Hinge
32	532 43 74-54	Spring Double Torsion
33	532 43 84-51	Shaft Mulch Plug
34	532 43 79-88	E-Ring 5/16
35	532 43 91-39	Grip Mulch Plug
36	532 43 90-98	Bolt J
37	532 06 91-80	Nut Lock #10-24 unc
38	819 07 08-18	Washer 7/32 x 1/2
39	532 43 92-42	Bungee

NOTE: All component dimensions given in U.S. inches
1 inch = 25.4 mm

