

ILLUSTRATED PARTS LIST

MODEL NO. 96041023601/02

CUSTOMER CATALOG NO. LTH2142DR

PRODUCT NO. 960 41 02-36

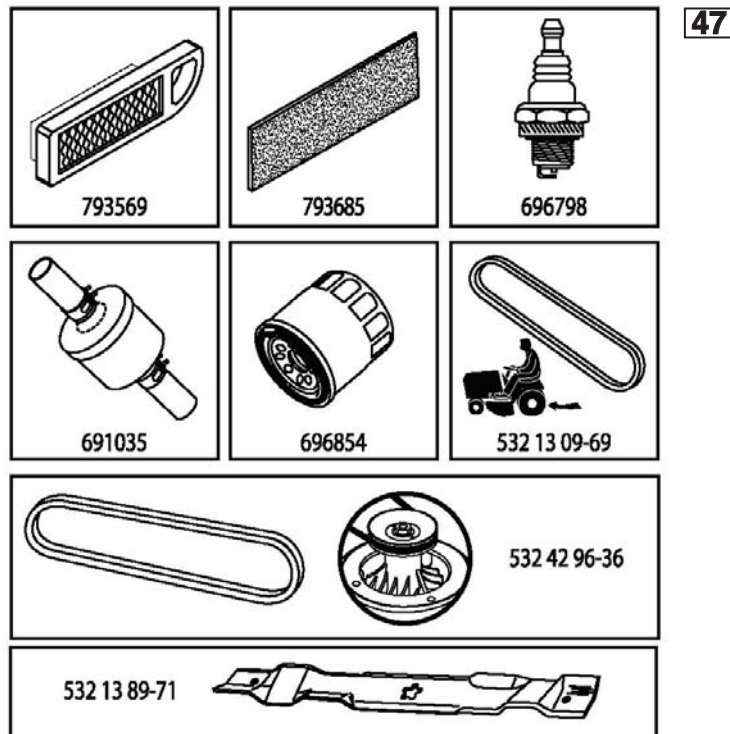

443836

**TRACTOR -- MODEL NO. LTH2142DR (96041023601/02), PRODUCT NO. 960 41 02-36
DECALS 27**

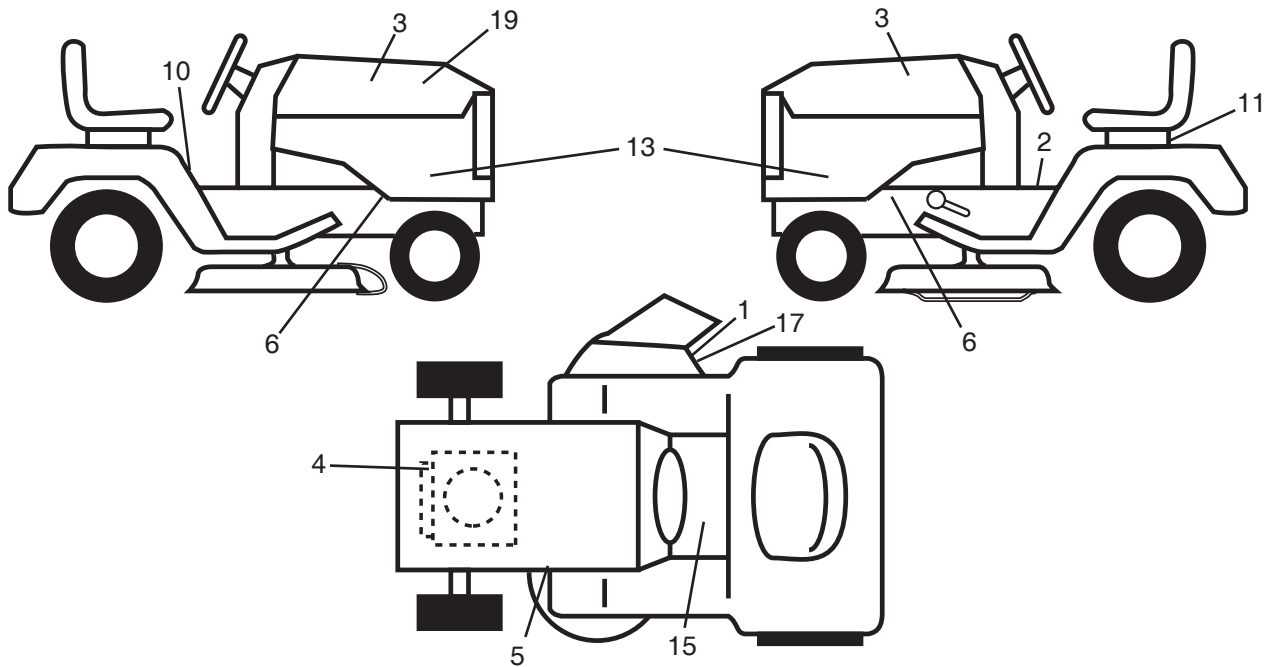

KEY NO.	PART NO.	DESCRIPTION
1	584 90 46-01	Decal, Deck/Deflect. Warning
2	581 57 80-01	Decal, Brake Parking Sandle
3	581 62 73-01	Decal, Hood
4	581 57 97-01	Decal, Warning Engine
5	581 58 00-01	Decal, V-Belt Sch.
6	581 57 96-01	Decal, Chassis Hot Muffler
10	581 57 81-01	Decal, Warning Symbols CE
11	532 14 50-05	Decal, Bat Dan/Poi P/L Sym
13	532 44 44-62	Decal, Sidepnl

KEY NO.	PART NO.	DESCRIPTION
15	581 72 40-01	Decal, Brake/Clutch Symbol
17	581 57 92-01	Decal, Cutfinger Warning
19	532 44 38-36	Decal, Replacement
--	581 72 46-01	Decal, Drawbar Load Limit
--	581 72 48-01	Decal, Bypass LT Hydro
--	532 43 96-81	Pad, Footrest LH
--	532 43 96-82	Pad, Footrest RH
--	587 23 80-26	Manual, Operator's (English)

WHEELS & TIRES

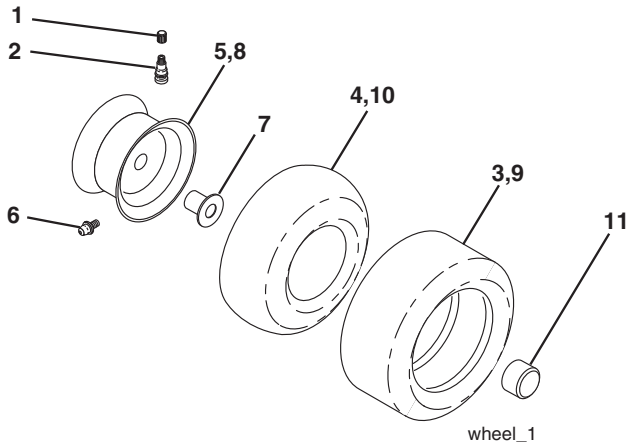

KEY NO.	PART NO.	DESCRIPTION
1	532 05 91-92	Cap Valve Tire
2	532 06 51-39	Stem Valve
3	532 10 62-22	Tire F Ts 15 x 6 0 - 6 Service
4	532 05 99-04	Tube Front (Service Item Only)
5	532 13 83-36	Rim Asm 6" Front Silver Service
6	532 12 49-57	Fitting Grease (Front Wheel Only)
7	532 12 49-59	Bearing Flange (Front Wheel Only)
8	532 13 83-37	Rim Asm 8" Rear Silver Service
9	532 12 20-82	Tire R Ts 20 x 10-8 C Service
10	532 12 49-26	Tube Rear (Service Item Only)
11	532 17 50-39	Cap Axle Blk 1 50 x 1 00
--	532 14 43-34	Sealant, Tire (10 oz. tube)

NOTE: All component dimensions given in U.S. inches
1 inch = 25.4 mm

TRACTOR--MODEL NO. LTH2142DR (96041023601/02), PRODUCT NO. 960 41 02-36

SCHEMATIC **38**

SCH12

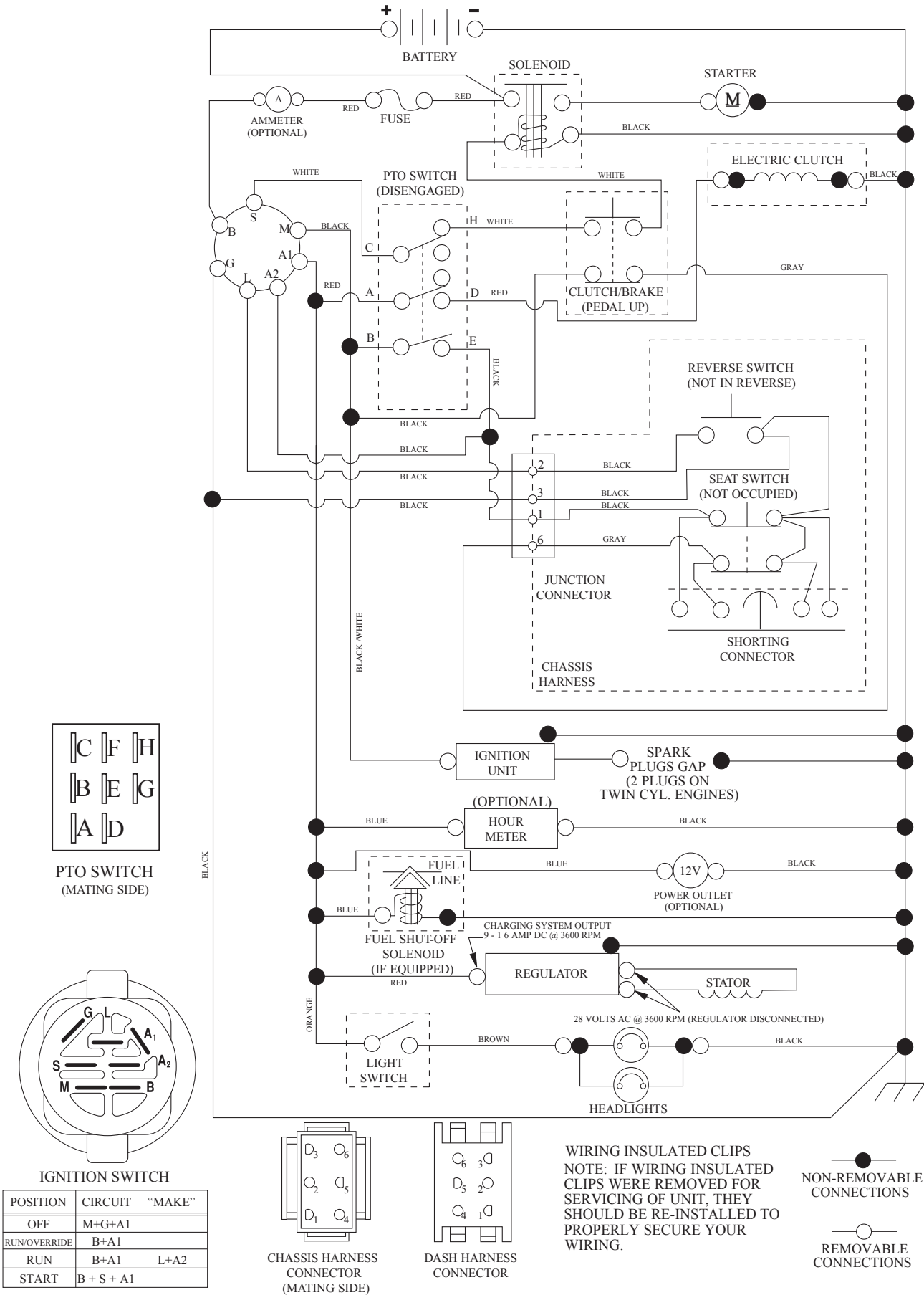

TRACTOR -- MODEL NO. LTH2142DR (96041023601/02), PRODUCT NO. 96041 02-36
ELECTRICAL **32**

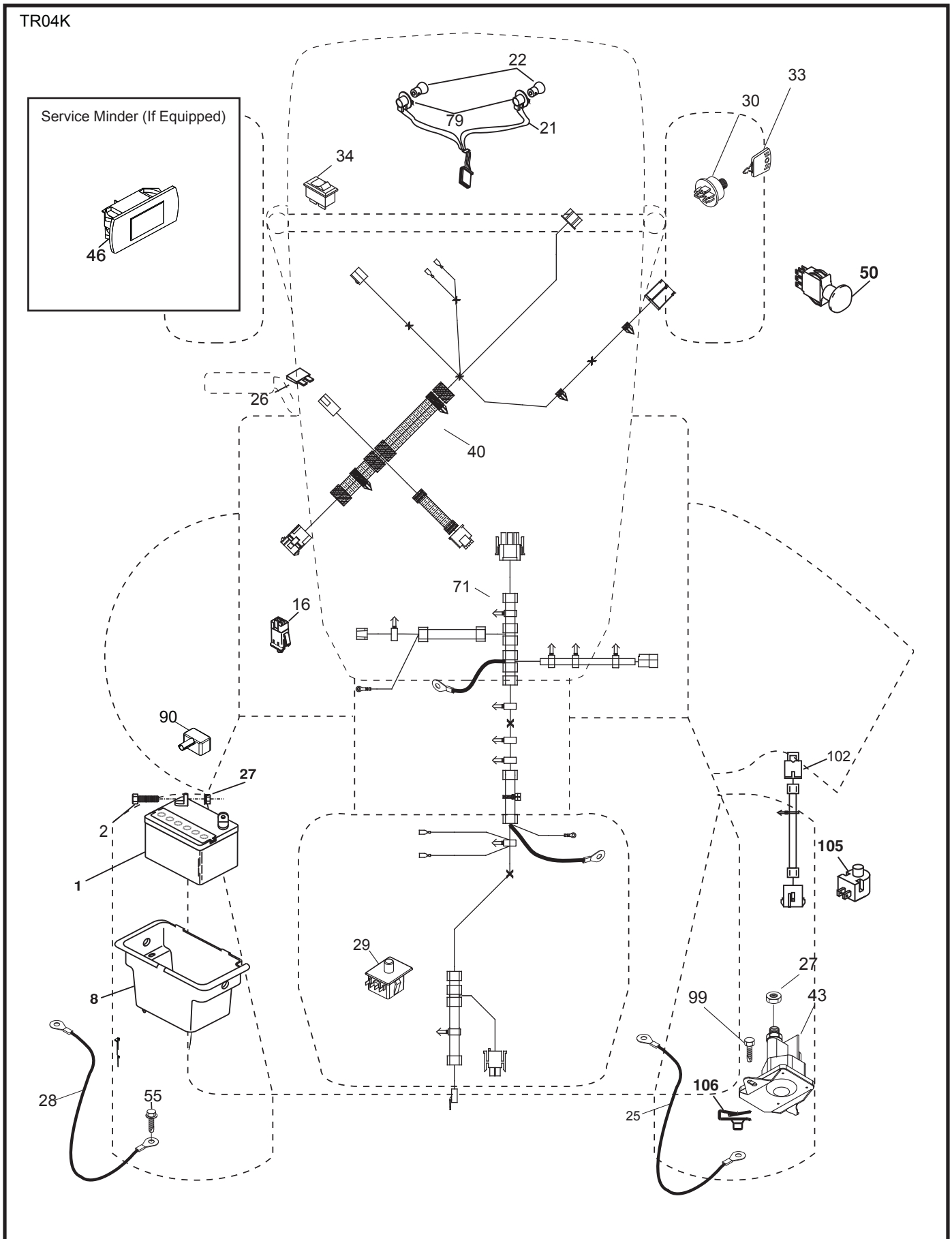

**TRACTOR--MODEL NO.LTH2142DR (96041023601/02), PRODUCT NO.96041 02-36
ELECTRICAL 32**

KEY NO.	PART NO.	DESCRIPTION
1	532 16 34-65	Battery
2	874 76 04-12	Bolt Hex Head 1/4-20 x 3/4
8	532 19 32-28	Box Battery
16	532 17 61-38	Switch Interlock Push-In
21	532 40 02-52	Harness Socket Light W/4152J
22	532 00 41-52	Bulb Light
25	581 49 80-01	Cable Starter
26	532 17 51-58	Fuse
27	873 51 04-00	Nut Keps Hex 1/4-20 unc
28	532 42 16-86	Cable, Ground
29	532 40 15-45	Switch, Seat
30	532 19 33-50	Switch, Ign
33	532 41 19-35	Key/Chain
34	532 11 07-12	Switch Light / Reset
40	581 02 32-01	Harness Ign. Dash/Lift
43	532 19 25-07	Solenoid
50	532 17 46-51	Switch PTO
55	817 06 05-12	Screw Thdrol 5/16-18 x 3/4 TYTT
71	581 02 30-01	Harness Ign. Chassis/Lift
79	532 17 52-42	Socket Asm
90	532 43 53-95	Cover Terminal
99	817 67 04-12	Screw Hexwsh
102	532 40 44-54	Harness Pigtail Tex ROS Tufftorq
105	532 40 75-68	Switch Reverse
106	532 17 48-14	Palnut 1/4 Lugs

NOTE: All component dimensions given in U.S. inches
1 inch = 25.4 mm

TRACTOR-- MODEL NO. LTH2142DR (96041023601/02), PRODUCT NO. 96041 02-36
CHASSIS AND ENCLOSURES **39**

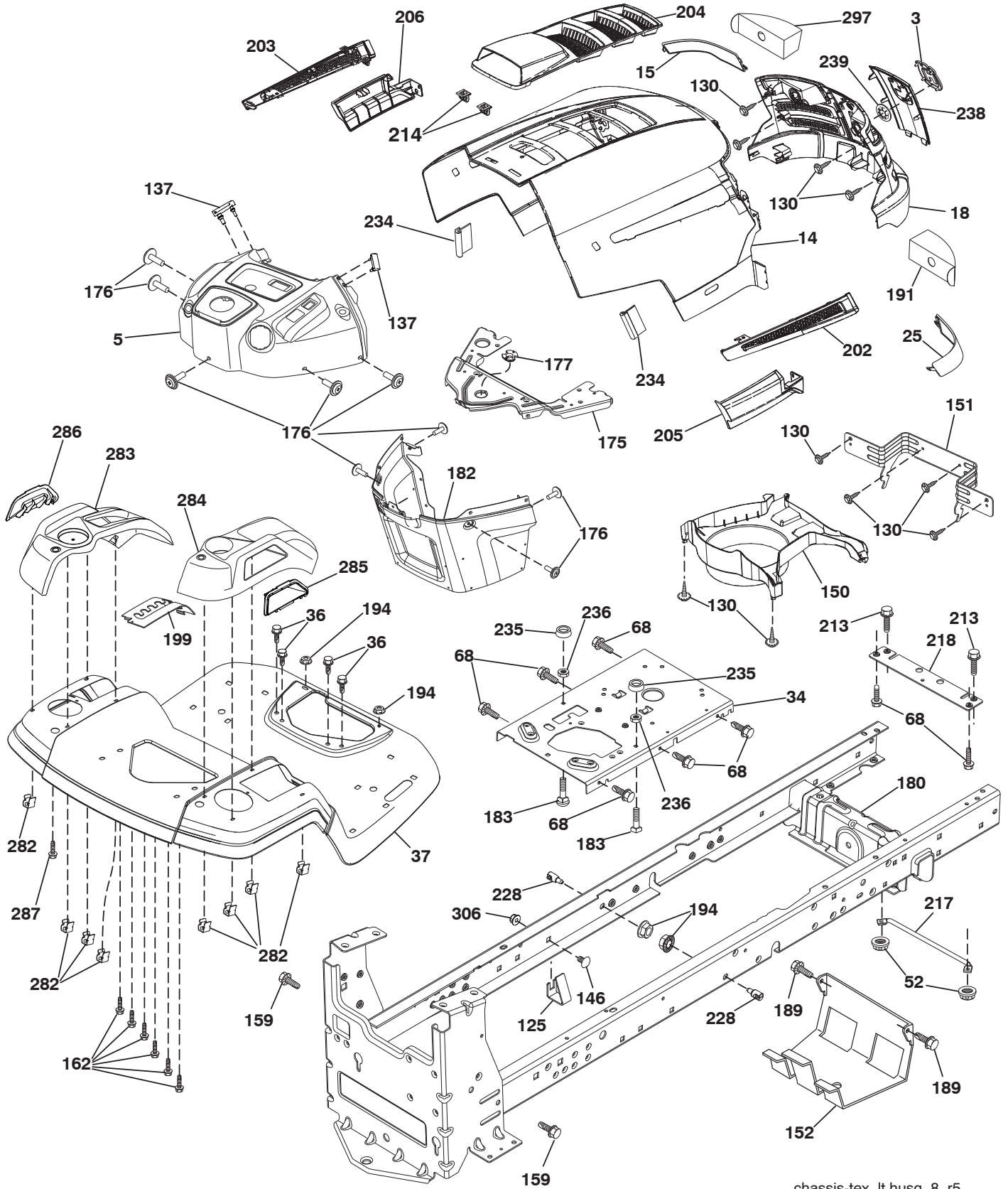

chassis-tex_lt husq_8_r5

**TRACTOR--MODEL NO.LTH2142DR (96041023601/02), PRODUCT NO.96041 02-36
CHASSIS AND ENCLOSURES 39**

KEY NO.	PART NO.	DESCRIPTION	KEY NO.	PART NO.	DESCRIPTION
3	581 05 63-01	Logo	203	532 44 13-43	Vent Side Hood LH
5	532 43 89-66	Dash	204	532 44 13-75	Vent Top Hood
14	532 44 12-67	Hood	205	532 44 13-44	Skirt Side RH
15	532 44 14-28	Lens LH	206	532 44 13-45	Skirt Side LH
18	532 44 13-68	Grille	213	874 76 05-12	Bolt 5/16-18 x 3/4
25	532 44 14-27	Lens RH	214	532 19 91-45	Clip Retainer
34	532 44 72-53	Plate Engine	217	532 40 91-67	Rod Pivot Hood
36	817 06 05-12	Screw 5/16-18 x 3/4	218	532 19 63-95	X-Piece Hood Stop
37	532 44 12-66	Fender	228	532 19 51-61	Stud Fastener
52	873 68 05-00	Nut Crown Lock 5/16	234	532 40 47-42	Bumper Hood
68	817 49 05-08	Screw THDROL 5/16-18 x 1/2	235	532 40 61-29	Spacer Fender
125	581 68 48-01	Clip Fuel Line	236	873 93-05-00	Nut Lock 5/16-18 unc Center
130	532 41 63-58	Screw #10 x 0.750 BOS Thread	238	532 44 13-74	Trim
137	532 40 75-90	Bumper, Dash	239	532 40 48-83	Clip Tinnerman
146	581 85 79-01	Bolt	282	532 41 41-10	Clip Retainer
150	532 40 66-62	Air Duct	283	532 44 20-39	Console Deck Lift
151	532 40 78-07	Bracket Pivot	284	532 43 98-23	Console Control Pedal
152	532 19 95-35	Shield Browning	285	532 41 63-15	Console Insert RH
159	817 00 06-12	Screw Hex Wsh Thdr 3/8-16 x 3/4	286	532 41 63-17	Console Insert LH
162	532 14 24-32	Screw	287	817 60 04-06	Screw Hex Washead 1/4-20 x 3/8
175	532 19 94-72	Crossmember	297	532 40 66-65	Insert Reflective LH
176	532 40 07-76	Screw 10-24 x 5/8	306	873 90 06-00	Nut Lock
177	532 19 52-28	Bushing Steering	--	532 40 09-44	Kit Bumper
180	532 19 54-57	Chassis			
182	532 40 71-76	Dash Lower			
183	874 52 05-20	Bolt 5/16-18 unc x 1-1/4			
189	817 00 05-12	Screw 5/16-18 x 3/4			
191	532 41 65-01	Insert Reflective RH			
194	873 90 05-00	Nut Lock Hex Flange 5/16-18			
199	532 41 34-85	Plate Deck Lift			
202	532 44 13-42	Vent Side Hood RH			

NOTE: All component dimensions given in U.S. inches
1 inch = 25.4 mm

**TRACTOR--MODEL NO. LTH2142DR (96041023601/02), PRODUCT NO. 960 41 02-36
DRIVE 40**

KEY NO.	PART NO.	DESCRIPTION
1	- - - - -	Transaxle, TUFFTORQ K46 CR (501051401) (Order parts from transaxle manufacturer.)
2	532 12 35-83	Key
15	819 13 13-16	Washer 13/32 x 13/16 x 16 Ga.
17	532 41 36-78	Spring, Brake
29	532 40 38-06	Rod, Brake
33	812 00 00-01	Ring E
35	532 40 10-31	Rod, Brake, Park
42	532 12 48-72	Cover, Foot Pedal
49	872 11 06-14	Bolt
50	532 19 43-27	Pulley Idler Flat
51	873 90 06-00	Lock Nut 3/8-16
52	532 19 43-26	Idler V-Groove
56	532 13 09-69	V-Belt, Drive
64	532 19 78-65	Shaft Asm. Pedal Brake Control
73	874 49 05-40	Bolt Hex Flghd 5/16-18 Gr. 5
99	532 41 57-42	Rod Spring Bypass
116	873 90 05-00	Nut Lock Hex Flange 5/16-18
125	817 00 05-12	Screw 5/16-18 x 3/4
143	817 49 05-08	Screw 5/16-18 x 1/2
153	532 12 47-88	Retainer Spring
159	876 02 04-12	Pin Cotter 1/8 x 3/4
160	532 16 94-84	Retainer Clip
161	532 10 57-09	Spring, Return, Clutch
163	532 44 82-75	Rod Pedal Control
166	532 42 91-64	Nut Push
167	532 40 52-57	Latch Brake Parking
170	532 19 43-22	Keeper Belt Centerspan
171	872 11 06-16	Bolt RDHD SQNK 3/8-16 unc x 2
183	532 13 70-57	Spacer Split
184	532 44 14-07	Handle Parking Brake
185	872 11 06-22	Bolt RDHD 3/8-16 unc x 2-3/4 Gr. 5
186	532 19 43-21	Spacer Retainer
187	819 13 32-10	Washer
188	532 19 43-23	Link Clutch Ground Drive
189	532 19 43-17	Bellcrank Ground Drive
190	532 19 43-18	Keeper Bellcrank Ground Drive
196	817 00 06-16	Screw 3/8-16 x 1
197	585 65 86-01	Bracket Clutch Anti-Rotation
205	532 12 17-48	Washer
210	532 40 09-80	Rocker Asm. Pedal Control
211	532 12 01-83	Bearing Nylon
214	532 42 12-63	Pedal Forward
215	532 40 17-23	Pedal Reverse
216	532 19 61-31	Bracket Pulley Idler
221	532 40 31-87	Retainer Spring Clip Handle
222	879 21 20-10	Washer 21/32 x 1-1/4 x 10 Ga.
225	532 40 33-19	Keeper Belt Trans.
227	817 49 05-12	Screw Thdrol. 5/16-18 x 3/4
230	532 18 89-67	Washer Hardened
325	585 66 85-02	Torque Strap K46 LT RH
326	585 67 08-02	Bracket Trq Stp 46 20" Tire RH
336	587 25 96-01	Bolt 5/16-18 x 1-3/4 Flanged

NOTE: All component dimensions given in U.S. inches
1 inch = 25.4 mm

TRACTOR-- MODEL NO. LTH2142DR (96041023601/02), PRODUCT NO. 96041 02-36
ENGINE **24**

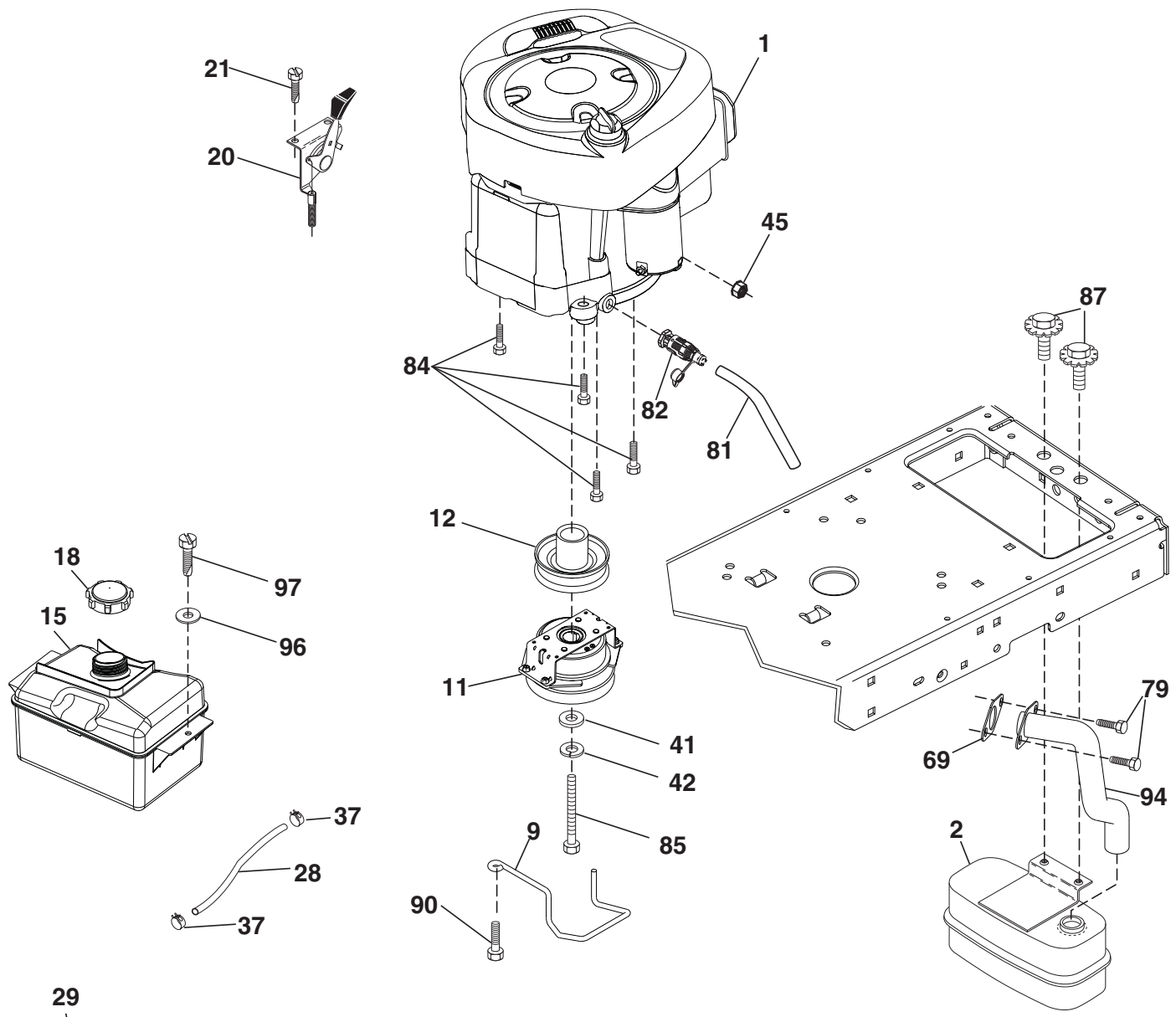

29

OPTIONAL EQUIPMENT

Spark Arrester

engine-tex_BS_138

**TRACTOR--MODEL NO. LTH2142DR (96041023601/02), PRODUCT NO. 960 41 02-36
ENGINE 24**

KEY NO.	PART NO.	DESCRIPTION
1	---	Engine Briggs 33M977-0002-G5 (581187001) (Order parts from engine manufacturer.)
2	580 53 23-01	Muffler
9	584 90 80-01	Keeper Belt Engine
11	587 24 15-01	Clutch
12	532 40 50-97	Pulley Engine
15	532 40 75-45	Tank Fuel 1.5
18	532 43 02-20	Cap Fuel
20	532 18 38-97	Control Throttle
21	532 41 63-58	Screw #10 x 0.750 BOS Thread
28	532 13 70-40	Fuel Line
29	532 13 71-80	Spark Arrester Kit
37	532 12 34-87	Clamp Hose
41	532 12 61-97	Washer 1-1/2 OD. x 15/32 ID x 250
42	810 04 07-00	Wahser Lock Hvy HLCL Spr. 7/16
45	873 51 04-00	Nut Keps Hex 1/4-20 unc
69	532 16 52-91	Gasket
79	532 19 23-34	Screw Socket HD. 5/16-18 x .75
81	532 14 84-56	Tube Drain Oil Easy
82	532 42 82-87	Valve Oil Drain
84	817 06 06-20	Screw 3/8-16 x 1 1/4
85	581 33 28-04	Bolt 7/16-20 x 3.5 x Gr. 5
87	532 17 18-77	Bolt 5/16-18 X 3/4
90	817 00 06-16	Screw 3/8-16 x 1
94	581 88 09-01	Tube Exhaust
96	819 09 14-16	Washer 9/32 x 7/8 x 16 Ga.
97	817 67 04-12	Screw 1/4-20 x 3/4

NOTE: All component dimensions given in U.S. inches
1 inch = 25.4 mm

Engine Power Rating Information

The gross power rating for individual gas engine models is labeled in accordance with SAE (Society of Automotive Engineers) code J1940 (Small Engine Power & Torque Rating Procedure), and rating performance has been obtained and corrected in accordance with SAE J1995 (Revision 2002-05). Torque values are derived at 3060 RPM; horsepower values are derived at 3600 RPM. Actual gross engine power will be lower and is affected by, among other things, ambient operating conditions and engine-to-engine variability. Given both the wide array of products on which engines are placed and the variety of environmental issues applicable to operating the equipment, the gas engine will not develop the rated gross power when used in a given piece of power equipment (actual "on-site" or net power). This difference is due to a variety of factors including, but not limited to, accessories (air cleaner, exhaust, charging, cooling, carburetor, fuel pump, etc.), application limitations, ambient operating conditions (temperature, humidity, altitude), and engine-to-engine variability. Due to manufacturing and capacity limitations, Briggs & Stratton may substitute an engine of higher rated power for this Series engine.

TRACTOR -- MODEL NO. LTH2142DR (96041023601/02), PRODUCT NO. 960 41 02-36
STEERING ASSEMBLY **41**

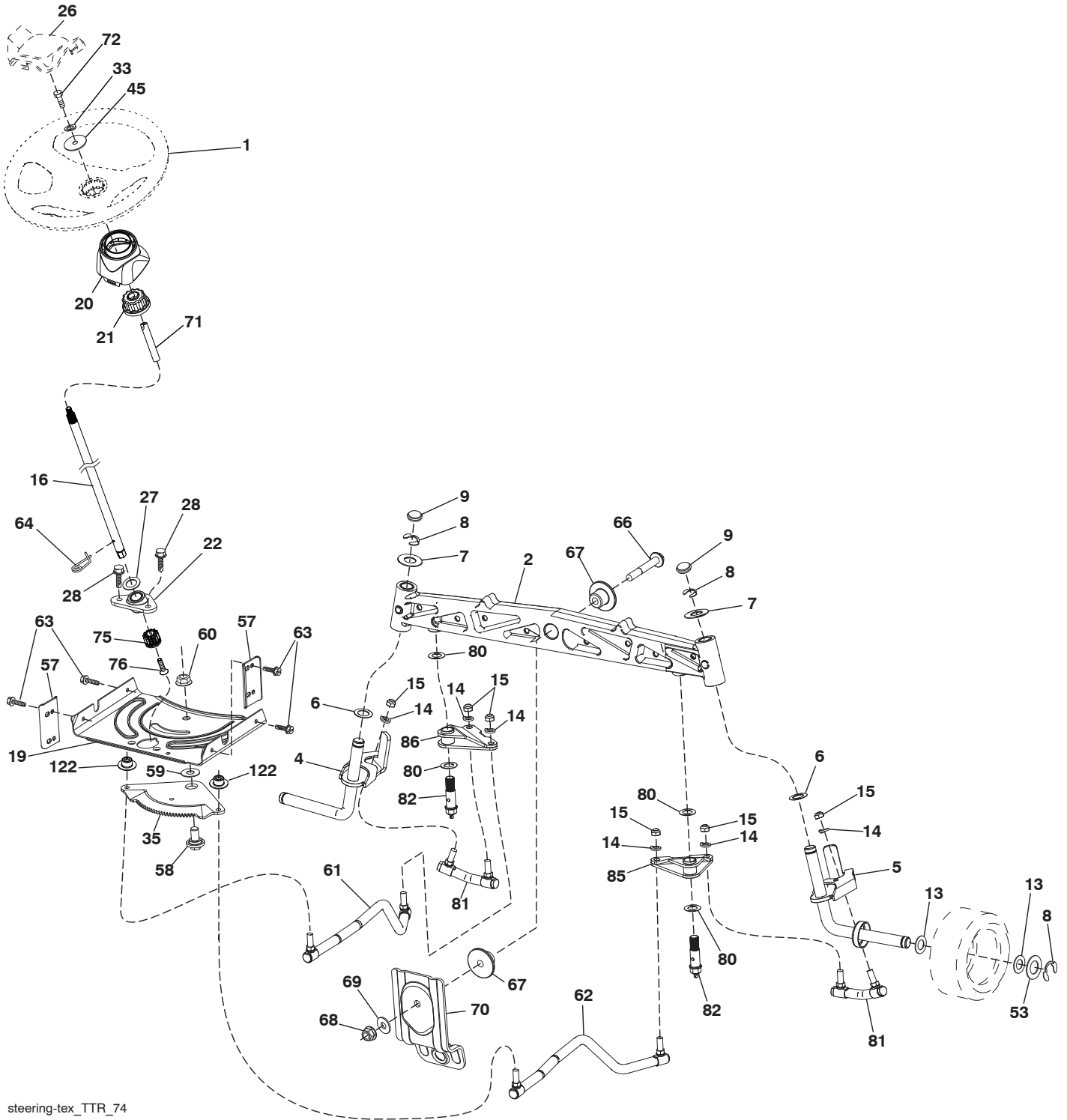

steering-tex_TTR_74

**TRACTOR--MODEL NO. LTH2142DR (96041023601/02), PRODUCT NO. 960 41 02-36
STEERING ASSEMBLY 41**

KEY NO.	PART NO.	DESCRIPTION
1	532 43 97-40	Wheel, Steering
2	532 43 68-70	Axle Asm., Front
4	532 43 68-73	Spindle Asm., LH
5	532 43 68-74	Spindle Asm., RH
6	532 12 49-31	Washer Thrust 0.75 x 1.23
7	532 12 17-48	Washer 25/32 x 1-5/8 x 16 Ga.
8	812 00 00-29	Ring, Klip #T5304-75
9	532 12 12-32	Cap, Spindle
13	532 12 17-49	Washer 25/32 x 1-1/4 x 16 Ga.
14	810 04 06-00	Washer, Lock 3/8
15	873 54 06-00	Nut, Crown Lock 3/8-24 unf
16	585 86 92-02	Shaft Steering
19	532 19 47-29	Plate Steering
20	532 44 14-25	Boot, Steering
21	532 43 77-47	Adapter, Wheel Steering
22	585 02 99-01	Bearing Asm.
26	532 43 97-43	Insert, Wheel Steering
27	819 21 16-16	Washer 21/32 x 1 x 16 Ga.
28	817 00 06-12	Screw 3/8-16 x 3/4
33	810 04 05-00	Washer 5/16
35	532 44 07-70	Gear, Sector Plate
45	819 11 38-12	Washer 11/32 ID x 2-3/8 OD x 12 Ga.
53	532 18 89-67	Washer Hardened .793 x 1.637 x .060
57	532 40 74-65	Bracket Upstop
58	532 19 47-47	Bolt Shoulder Sector Pivot CFM
59	532 19 47-48	Washer Thrust Sector Steering
60	873 97 10-00	Nut Flange Lock 5/8-11
61	532 43 68-84	Draglink, LH
62	532 43 68-85	Draglink, RH
63	817 00 05-12	Screw 5/16-18 x 3/4
64	532 19 98-49	Retainer Clip Spring Steering
66	871 02 07-48	Bolt Hex Fghd 7/16-14 x 3 Serr
67	532 19 47-37	Bushing PM Front Axle
68	873 90 07-00	Nut Lock Flange 7/16-14 Gr. 5
69	532 19 91-62	Washer 1.5 x .505 x .118
70	532 19 61-97	Bracket Deck Susp. Front
71	532 19 07-52	Shaft Extension
72	532 42 89-82	Bolt 5/16-18 x 4
75	580 68 37-01	Pinion
76	580 68 36-01	Screw
80	532 00 13-70	Washer
81	532 43 68-87	Link Cross RH
82	532 43 68-77	Pivot Bolt
85	532 44 18-73	Pivot RH
86	532 44 18-72	Pivot LH
122	532 44 49-62	Cap Gear

NOTE: All component dimensions given in U.S. inches
1 inch = 25.4 mm

TRACTOR--MODEL NO. LTH2142DR (96041023601/02), PRODUCT NO. 960 41 02-36
MOWER DECK 44

KEY NO.	PART NO.	DESCRIPTION
1	532 43 98-17	Mower Deck Assembly, 42"
6	532 19 51-86	Arm Susp. Rear
11	532 13 89-71	Blade Mower 42" Hi-Lift (for bagging and discharging)
12	584 30 93-01	Screw 7/16-20 x 1 Hex
13	587 25 65-01	Shaft Assembly, Mandrel
14	532 18 72-81	Housing, Mandrel
15	585 32 39-01	Bearing, Mandrel
19	532 19 65-39	Bolt, Shoulder
20	532 15 97-70	Baffle, Vortex
21	873 68 05-00	Nut
23	532 19 25-57	Bracket, Deflector Mower 42"
24	532 10 53-04	Cap, Sleeve 80 x 112 Blk Mower
25	532 19 70-26	Spring, Torsion, Deflector
26	532 11 04-52	Nut, Push Phos & Oil
27	532 40 30-04	Shield, Deflector 42" Blk
29	532 13 14-91	Rod, Hinge 42" 6 75 W/G
30	532 17 39-84	Screw Thdrol
32	532 15 35-35	Pulley, Mandrel
33	532 40 02-34	Nut, Toplock
34	872 11 06-12	Bolt Carr SH 3/8-16 x 1-1/2 Gr. 5
36	532 19 73-79	Pulley Idler Flat
40	873 90 06-00	Nut Lock 3/8-16
55	532 43 71-10	Arm, Idler
56	532 19 90-92	Spacer, Retainer
57	817 00 06-16	Screw 3/8-16 x 1
59	532 14 10-43	Guard TUV Idler
62	872 11 06-16	Bolt Rdhd Sqnk 3/8-16 unc x 2
68	532 14 49-59	V-Belt, 42" Mower
69	872 14 05-05	Bolt, Carriage 5/16-18 x 5/8
116	532 12 48-42	Bolt, Shoulder
117	532 18 86-06	Wheel, Gauge
119	819 12 14-14	Washer 3/8 x 7/8 x 14
145	532 19 31-97	Pulley, Idler, Flat
188	532 19 51-61	Stud Fastner W/D Anti-Rotation
189	873 90 05-00	Nut Lock Hex Flange 5/16-18
190	532 19 72-51	Spring Mower Drive
241	532 15 29-27	Screw TT #10-32.5 3/8 Flange
242	532 41 55-98	Port Washout
--	587 25 33-01	Mandrel Assembly (Includes Housing (Key#14), Shaft assembly (Key#13) and Bearing Only (Key#15) - Pulley/Nut/Washer and Blade Bolt/Washers Not Included)
--	532 43 93-54	Replacement Mower, Complete (Std. deck Order separately gauge wheel components Key Nos. 116-119)

NOTE: All component dimensions given in U.S. inches
1 inch = 25.4 mm

TRACTOR -- MODEL NO. LTH2142DR (96041023601/02), PRODUCT NO. 960 41 02-36
MOWER LIFT 45

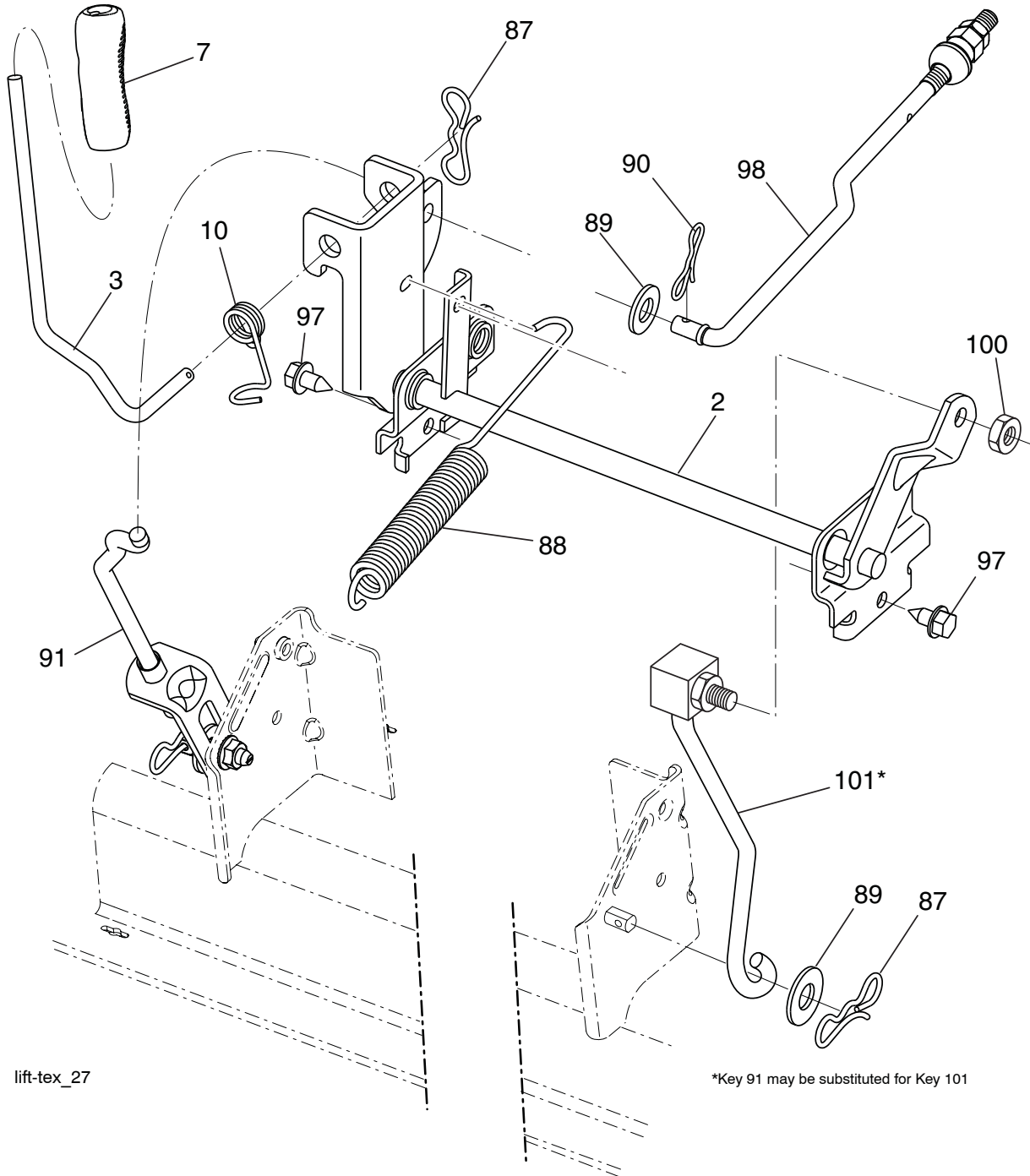

lift-tex_27

*Key 91 may be substituted for Key 101

KEY NO.	PART NO.	DESCRIPTION
2	532 42 20-27	Shaft Asm., Lift
3	532 19 52-31	Lever Asm., Lift RH
7	580 96 23-01	Grip, Lever
10	532 19 63-14	Spring Torsion
87	532 19 42-09	Pin Cotter 7/16 Bow Tie Lock
88	532 41 07-10	Spring Lift Assist
89	819 19 19-12	Washer Clear Zinc
90	532 19 42-08	Pin Cotter 5/16 Bow Tie Lock

KEY NO.	PART NO.	DESCRIPTION
91	532 19 51-81	Link Lift Susp Mower Rear
97	817 00 06-12	Screw Hex WSH THDR 3/8-16 x 3/4
98	532 19 52-70	Link Lift Susp. Front Mower
100	873 93 06-00	Nut Centerlock 3/8-16
101	532 40 70-03	Link Asm. Lift Fxd

NOTE: All component dimensions given in U.S. inches
 1 inch = 25.4 mm

**TRACTOR--MODEL NO. LTH2142DR (96041023601/02), PRODUCT NO. 96041 02-36
SEAT ASSEMBLY 42**

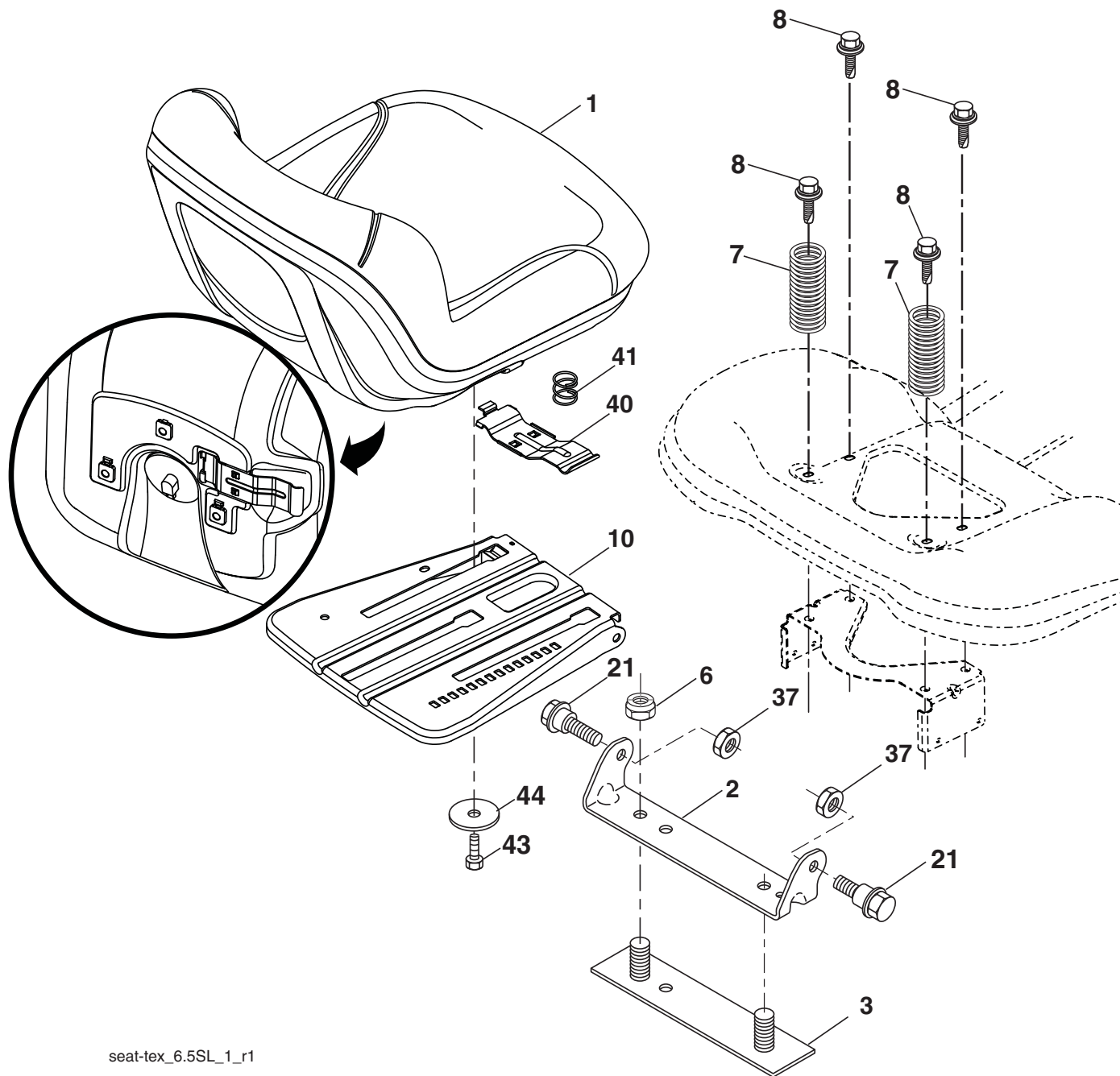

seat-tex_6.5SL_1_r1

KEY NO.	PART NO.	DESCRIPTION
1	532 43 98-22	Seat
2	532 18 01-66	Bracket Pivot Fender
3	532 14 06-75	Strap, Asm Fender
6	873 80 06-00	Nut, Lock w/Ins. 3/8-16 unc
7	532 12 41-81	Spring, Seat Cprsn
8	532 17 18-77	Bolt 5/16-18 unc x 3/4 w/Sems
10	532 19 69-77	Pan, Seat
21	532 17 18-52	Bolt, Shoulder 5/16-18

KEY NO.	PART NO.	DESCRIPTION
37	873 80 05-00	Nut, Lock 5/16-18 unc
40	532 19 76-61	Handle Slide
41	532 19 82-00	Spring Latch Seat
43	874 76 06-12	Bolt Fin Hex 3/8-16 unc x 3/4
44	819 13 38-12	Washer 13/32 x 2-3/8 x 12 Ga.

NOTE: All component dimensions given in U.S. inches
1 inch = 25.4 mm

