

ILLUSTRATED PARTS LIST

MODEL NO. 96041024201

CUSTOMER CATALOG NO. LTH154

PRODUCT NO. 960 41 02-42

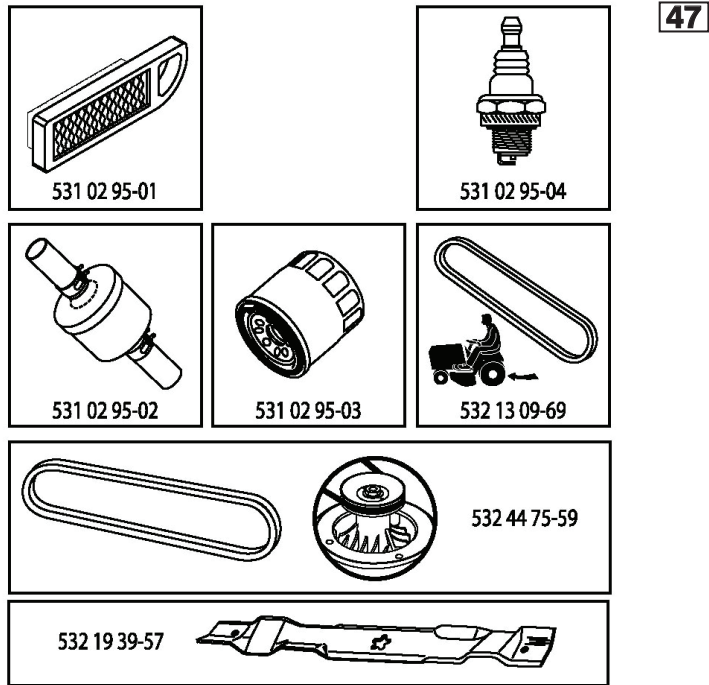

448060

**TRACTOR - - MODEL NO. LTH154 (96041024201), PRODUCT NO. 960 41 02-42
DECALS 27**

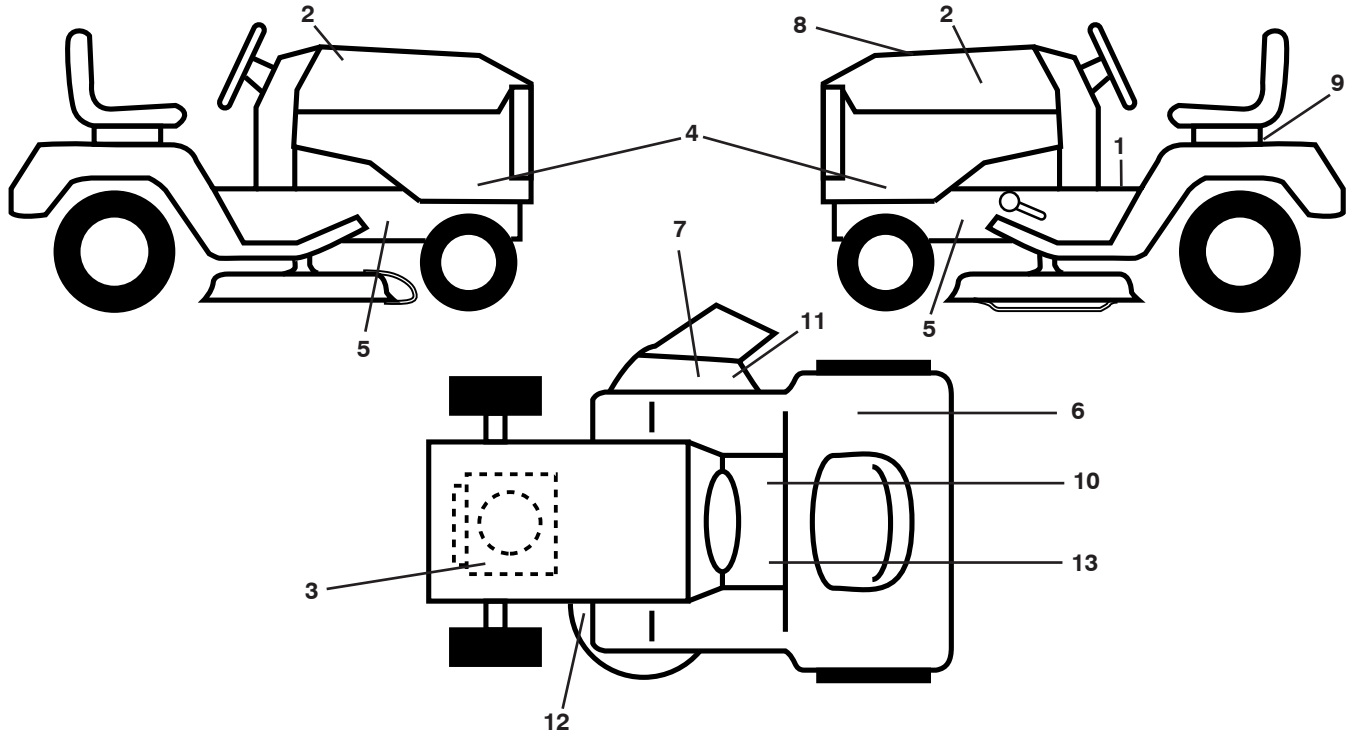

KEY NO.	PART NO.	DESCRIPTION
1	581 57 81-01	Decal, Operators
2	581 62 73-01	Decal, Hood
3	581 57 97-01	Decal, Warning Eng. Symbols
4	532 44 80-69	Decal, Hood Panel
5	581 57 96-01	Decal, Chassis Hot Muffler
6	581 72 41-01	Decal, Fender 100 DB/CE
7	581 57 91-01	Decal, Cutfinger CE
8	532 44 80-60	Decal, Rpl Kohl
9	532 14 50-05	Decal, Battery Dnge/Poi
10	581 57 80-01	Decal, Saddle Brake Parking
11	581 57 92-01	Decal, Warning

KEY NO.	PART NO.	DESCRIPTION
12	581 58 00-03	Decal, Mower V-Belt Schematic
13	581 72 40-01	Decal, Brake/Clutch Symbol
--	581 72 48-01	Decal, Bypass
--	581 72 46-01	Decal, Drawbar
--	532 43 96-81	Pad, Footrest, LH
--	532 43 96-82	Pad, Footrest, RH
--	580 30 42-40	Manual Oper. Euro
--	580 30 49-50	Manual Oper. Scand
--	580 30 49-20	Manual Oper. E-Bloc
--	580 30 49-30	Manual Oper. Baltic

WHEELS AND TIRES

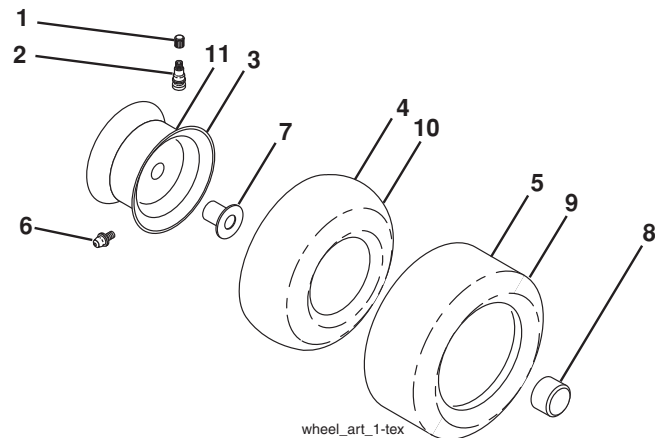

KEY NO.	PART NO.	DESCRIPTION
1	532 05 91-92	Cap Valve Tire
2	532 06 51-39	Stem Valve
3	532 13 83-36	Rim Asm 6" Front
4	532 05 99-04	Tube Front (Service Item Only)
5	532 10 62-22	Tire F T 15 x 6 0 - 6
6	532 12 49-57	Fitting Grease (Front Wheel Only)
7	532 12 49-59	Bearing Flange (Front Wheel Only)
8	532 17 50-39	Cap Axle Blk 1 50 x 1 00
9	532 42 05-31	Tire R 18 x 9.5-8 Turf Saver LT
10	532 12 49-26	Tube Rear (Service Item Only)
11	532 13 83-37	Rim Asm 8" Rear
--	532 14 43-34	Sealant, Tire (10 oz. Tube)

NOTE: All component dimensions given in U.S. inches
1 inch = 25.4 mm

TRACTOR - - MODEL NO. LTH154 (96041024201), PRODUCT NO. 960 41 02-42 SCHEMATIC 38

SCH12

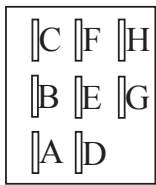
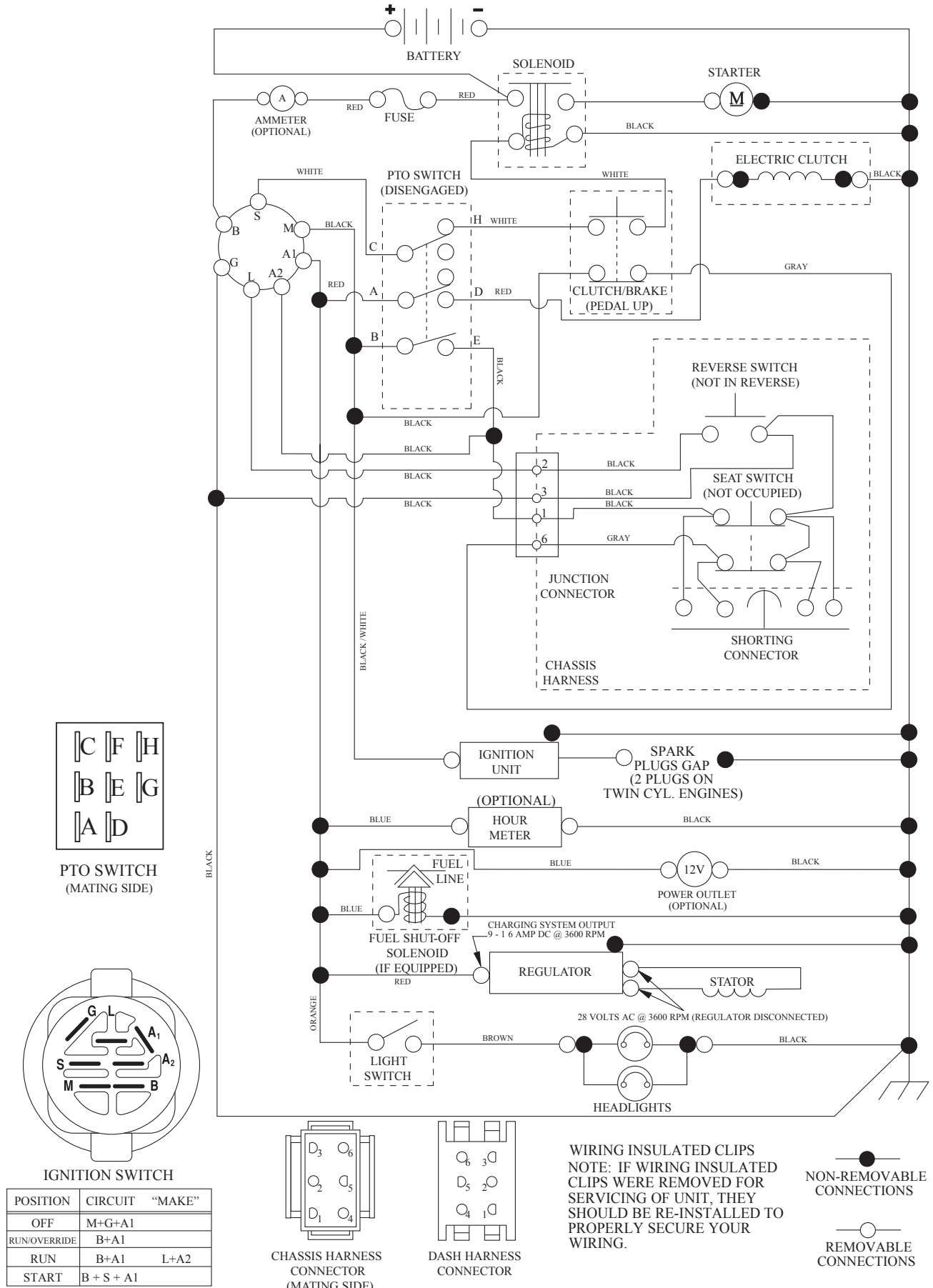

PTO SWITCH
(MATING SIDE)

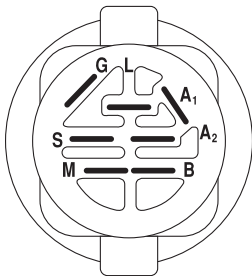

IGNITION SWITCH

POSITION	CIRCUIT	"MAKE"
OFF	M+G+A1	
RUN/OVERRIDE	B+A1	
RUN	B+A1	L+A2
START	B+S+A1	

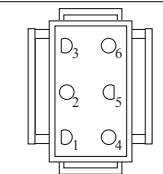

CHASSIS HARNESS
CONNECTOR
(MATING SIDE)

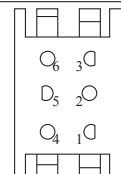

DASH HARNESS
CONNECTOR

WIRING INSULATED CLIPS
NOTE: IF WIRING INSULATED
CLIPS WERE REMOVED FOR
SERVICING OF UNIT, THEY
SHOULD BE RE-INSTALLED TO
PROPERLY SECURE YOUR
WIRING.

NON-REMOVABLE
CONNECTIONS

REMOVABLE
CONNECTIONS

TRACTOR - - MODEL NO. LTH154 (96041024201), PRODUCT NO. 960 41 02-42
ELECTRICAL **32**

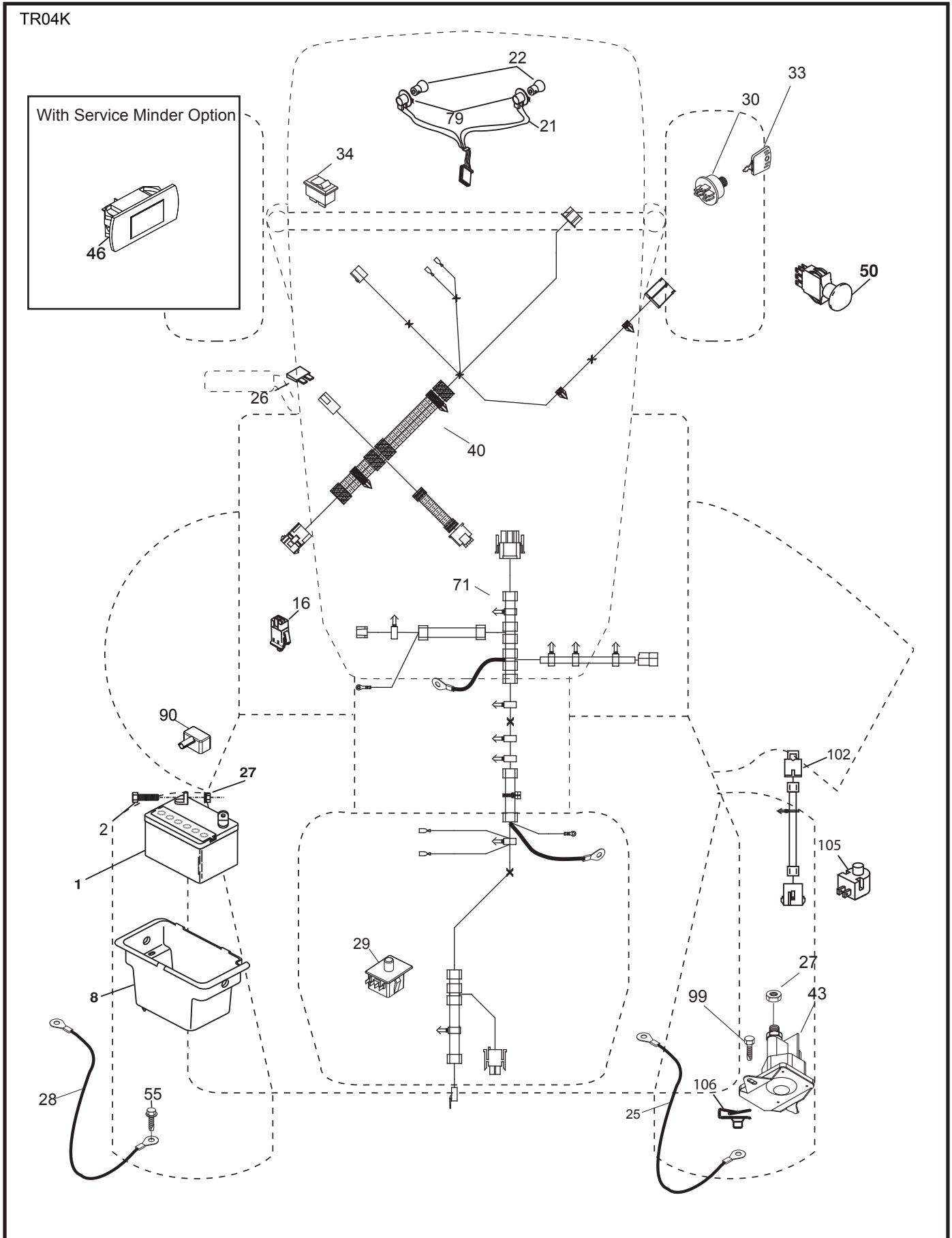

**TRACTOR - - MODEL NO. LTH154 (96041024201), PRODUCT NO. 960 41 02-42
ELECTRICAL 32**

KEY NO.	PART NO.	DESCRIPTION
1	532 16 34-65	Battery
2	874 76 04-12	Bolt Hex Head 1/4-20 x 3/4
8	532 19 32-28	Box Battery
16	532 17 61-38	Switch Interlock Push-In
21	532 40 02-52	Harness Socket Light W/4152J
22	532 00 41-52	Bulb Light
25	581 49 80-01	Cable Starter
26	532 17 51-58	Fuse
27	873 51 04-00	Nut Keps Hex 1/4-20 unc
28	532 42 16-86	Cable, Ground
29	532 40 15-45	Switch, Seat
30	532 19 33-50	Switch, Ign
33	532 41 19-35	Key/Chain
34	532 11 07-12	Switch Light / Reset
40	581 02 32-01	Harness Ign. Dash/Lift
43	532 19 25-07	Solenoid
50	532 17 46-51	Switch PTO
55	817 06 05-12	Screw Thdrol 5/16-18 x 3/4 TYTT
71	581 02 30-01	Harness Ign. Chassis/Lift
79	532 17 52-42	Socket Asm
90	532 43 53-95	Cover Terminal
99	817 67 04-12	Screw Hexwsh
102	532 40 44-54	Harness Pigtail Tex ROS Tufftorq
105	532 40 75-68	Switch Reverse
106	532 17 48-14	Palnut 1/4 Lugs

NOTE: All component dimensions given in U.S. inches
1 inch = 25.4 mm

TRACTOR - - MODEL NO. LTH154 (96041024201), PRODUCT NO. 960 41 02-42
CHASSIS AND ENCLOSURES **39**

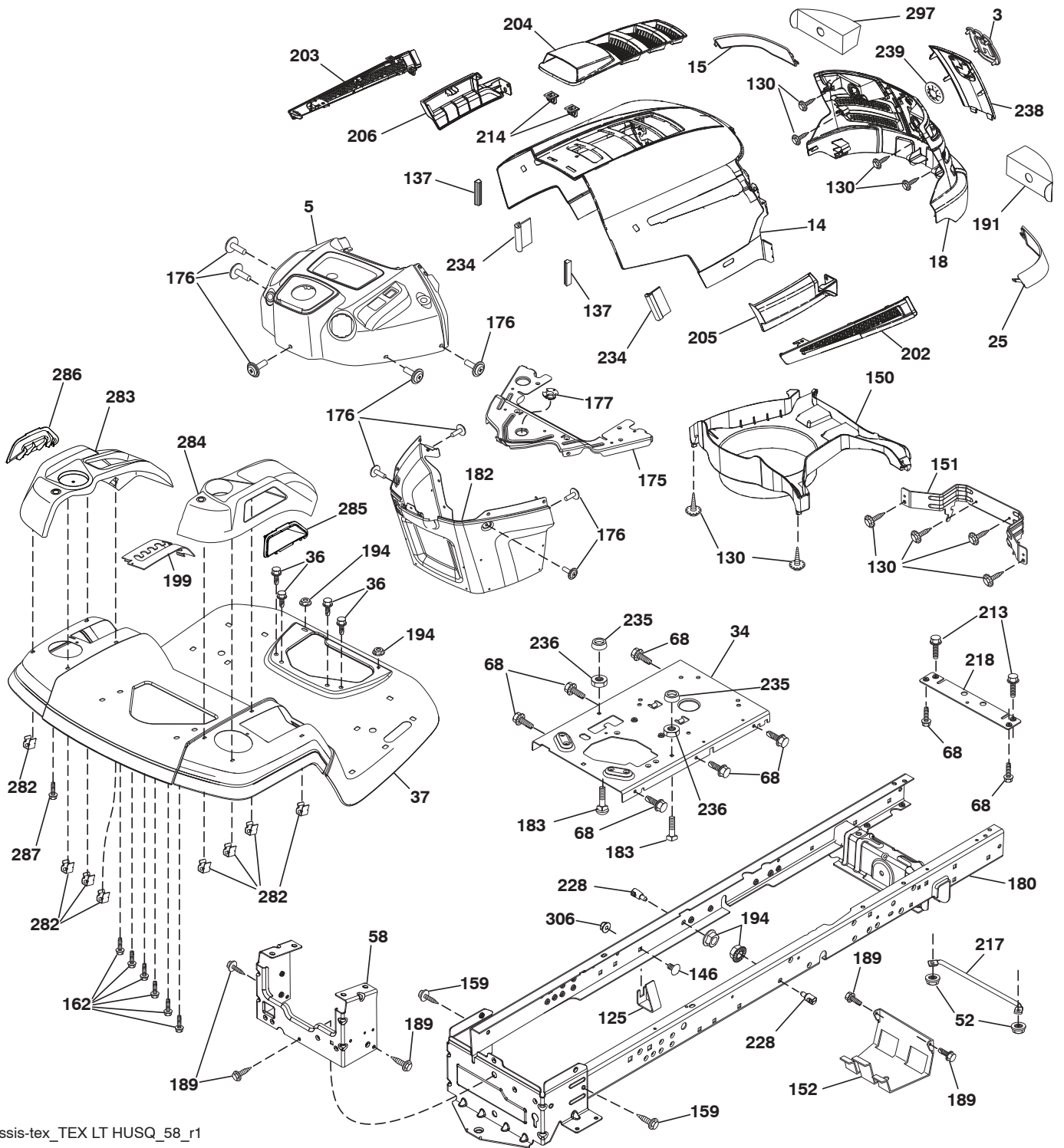

chassis-tex_TEX LT HUSQ_58_r1

**TRACTOR - - MODEL NO. LTH154 (96041024201), PRODUCT NO. 960 41 02-42
CHASSIS AND ENCLOSURES 39**

KEY NO.	PART NO.	DESCRIPTION	KEY NO.	PART NO.	DESCRIPTION
3	581 05 63-01	Logo	199	532 41 34-85	Plate Deck Lift
5	532 43 89-66	Dash	202	532 44 13-42	Vent Side Hood RH
14	532 44 12-67	Hood	203	532 44 13-43	Vent Side Hood LH
15	532 44 14-28	Lens LH	204	532 44 13-75	Vent Top Hood
18	532 44 13-68	Grille	205	532 44 13-44	Skirt Side RH
25	532 44 14-27	Lens RH	206	532 44 13-45	Skirt Side LH
34	580 91 08-01	Plate Engine	213	874 76 05-12	Bolt 5/16-18 x 3/4
36	817 06 05-12	Screw 5/16-18 x 3/4	214	532 19 91-45	Clip Retainer
37	532 44 12-66	Fender	217	532 40 91-67	Rod Pivot Hood
52	873 68 05-00	Nut Crown Lock 5/16	218	532 19 63-95	X-Piece Hood Stop
58	532 41 22-80	Drawbar, Upper	228	532 19 51-61	Stud Fastener
68	817 49 05-08	Screw THDROL 5/16-18 x 1/2	234	532 40 47-42	Bumper Hood
125	581 68 48-01	Clip Fuel Line	235	532 40 61-29	Spacer Fender
130	532 41 63-58	Screw 10 x .750 BOSThread	236	873 93 05-00	Nut Lock 5/16-18 unc
137	532 40 75-90	Bumper Dash	238	532 44 13-74	Trim
146	581 85 79-01	Bolt	239	532 40 48-83	Clip Tinnerman
150	532 40 75-37	Air Duct	282	532 41 41-10	Clip Retainer Console
151	532 40 78-07	Bracket Pivot	283	532 44 20-39	Console Deck Lift
152	532 19 95-35	Shield Browning	284	532 43 98-23	Console Shift
159	817 00 06-12	Screw 3/8-7/16 x 3/4	285	532 41 63-15	Console Insert RH
162	532 14 24-32	Screw	286	532 41 63-17	Console Insert LH
175	532 19 94-72	Crossmember	287	817 60 04-06	Screw Hex Washhead 1/4-20 x 3/8
176	532 40 07-76	Screw 10-24 x 5/8	297	532 40 66-65	Insert Reflective LH
177	532 19 52-28	Bushing Steering	306	873 90 06-00	Nut Lock
180	532 41 50-63	Chassis	- - -	532 43 99-76	Plug Dash SRVMNDR
182	532 40 71-76	Dash Lower			
183	874 52 05-20	Bolt 5/16-18 x 1-1/4			
189	817 00 05-12	Screw 5/16-18 x 3/4			
191	532 41 65-01	Insert Reflective RH			
194	873 90 05-00	Nut Lock Hex Flange 5/16-18			

NOTE: All component dimensions given in U.S. inches
1 inch = 25.4 mm

TRACTOR - - MODEL NO. LTH154 (96041024201), PRODUCT NO. 960 41 02-42
DRIVE **40**

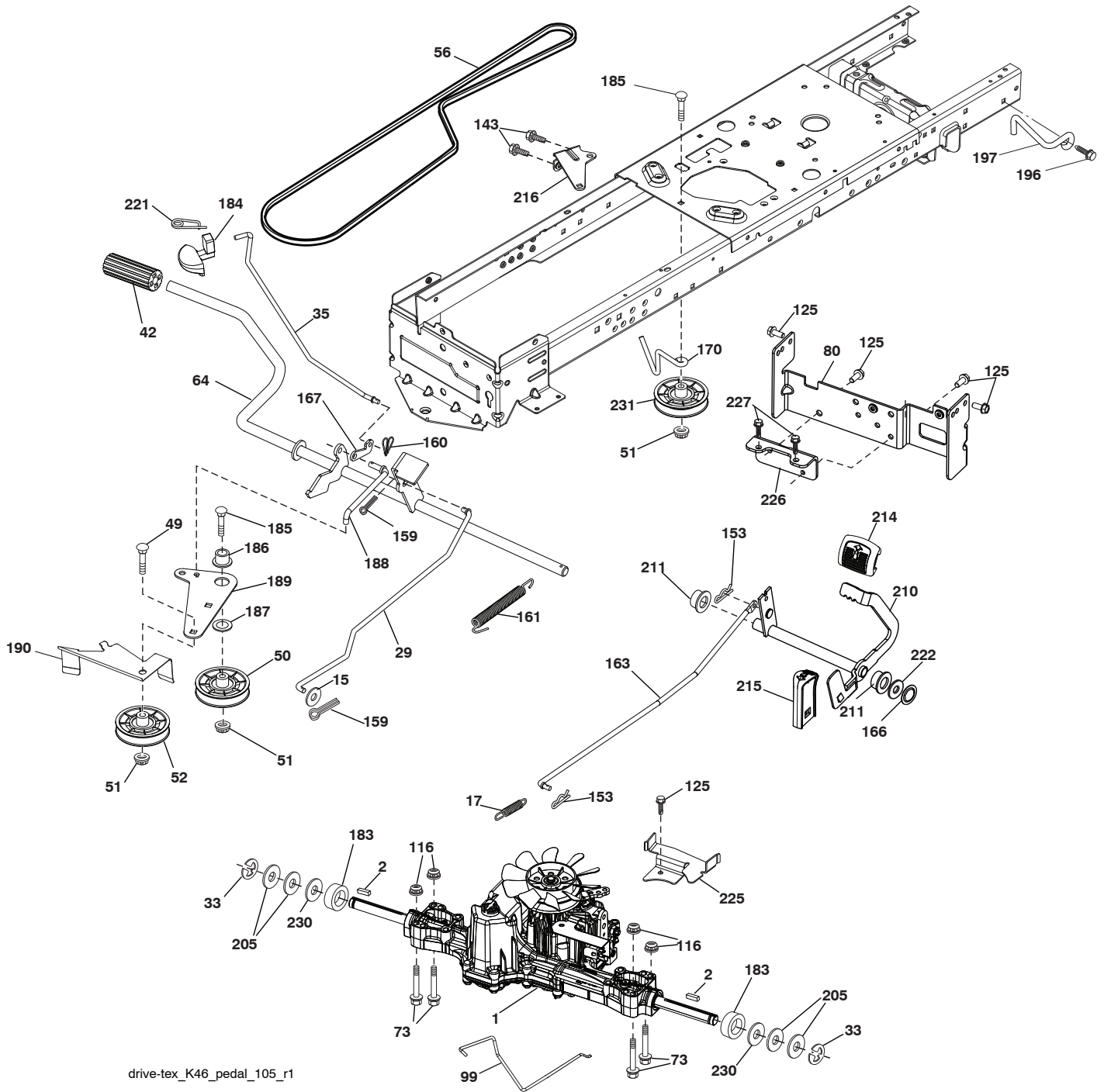

drive-tex_K46_pedal_105_r1

**TRACTOR - - MODEL NO. LTH154 (96041024201), PRODUCT NO. 960 41 02-42
DRIVE 40**

KEY NO.	PART NO.	DESCRIPTION	KEY NO.	PART NO.	DESCRIPTION
1	- - - - -	Transaxle, TUFFTORQ K46 BT (426120) (Order parts from trans-axle manufacturer.)	183	532 13 70-57	Spacer Split
2	532 12 35-83	Key	184	532 44 14-07	Handle Parking Brake
15	819 13 13-16	Washer 13/32 x 13/16 x 16 Ga.	185	872 11 06-22	Bolt Rdhd Sqnk 3/8-16 x 2-3/4 Gr. 5
17	532 41 36-78	Spring Brake	186	532 19 43-21	Spacer Retainer
29	532 40 38-06	Rod, Brake	187	819 13 32-10	Washer
33	812 00 00-01	Ring E	188	532 19 43-23	Link Clutch Ground Drive
35	532 40 10-31	Rod Brake Park	189	532 19 43-17	Bellcrank Ground Drive
42	532 12 48-72	Cover Foot Pedal	190	532 19 43-18	Keeper Bellcrank Ground Drive
49	872 11 06-14	Bolt	196	817 00 06-16	Screw 3/8-16 x 1
50	532 19 43-27	Pulley Idler Flat	197	532 19 58-04	Link Clutch Anti-Rotation
51	873 90 06-00	Lock Nut 3/8-16	205	532 12 17-48	Washer
52	532 19 43-26	Idler V-Groove 910" Offset	210	532 40 09-80	Rocker Asm. Pedal
56	532 13 09-69	V-Belt Drive	211	532 12 01-83	Bushing Brake Shaft
64	532 19 78-65	Shaft Asm. Pedal Brake Control	214	532 42 12-63	Pedal Forward
73	874 49 05-40	Bolt 5/16-18 x 2-1/2 Gr. 5	215	532 40 17-23	Pedal Reverse
80	532 44 06-19	Strap Torque	216	532 19 61-31	Bracket Pulley Idler
99	532 41 57-42	Rod Bypass	221	532 40 31-87	Retainer Spring Clip Handle
116	873 90 05-00	Nut Lock Hex Flange 5/16-18	222	879 21 20-10	Washer 21/32 x1-1/4 10 Ga.
125	817 00 05-12	Screw 5/16-18 x 3/4	225	532 40 33-19	Keeper Belt Trans.
143	817 49 05-08	Screw 5/16-18 x 1/2	226	532 40 15-64	Bracket Mount Torque
153	532 12 47-88	Retainer Spring	227	817 49 05-12	Screw 5/16-18 x 3/4
159	876 02 04-12	Pin Cotter 1/8 x 3/4	230	532 18 89-67	Washer Hardened
160	532 16 94-84	Retainer Clip	231	532 40 72-87	Idler V-Groove
161	532 10 57-09	Spring Return Clutch			
163	532 44 82-75	Rod Control Pedal			
166	532 42 91-64	Nut Push			
167	532 40 52-57	Latch Brake Parking			
170	532 41 34-30	Keeper Belt Centerspan			

NOTE: All component dimensions given in U.S. inches
1 inch = 25.4 mm

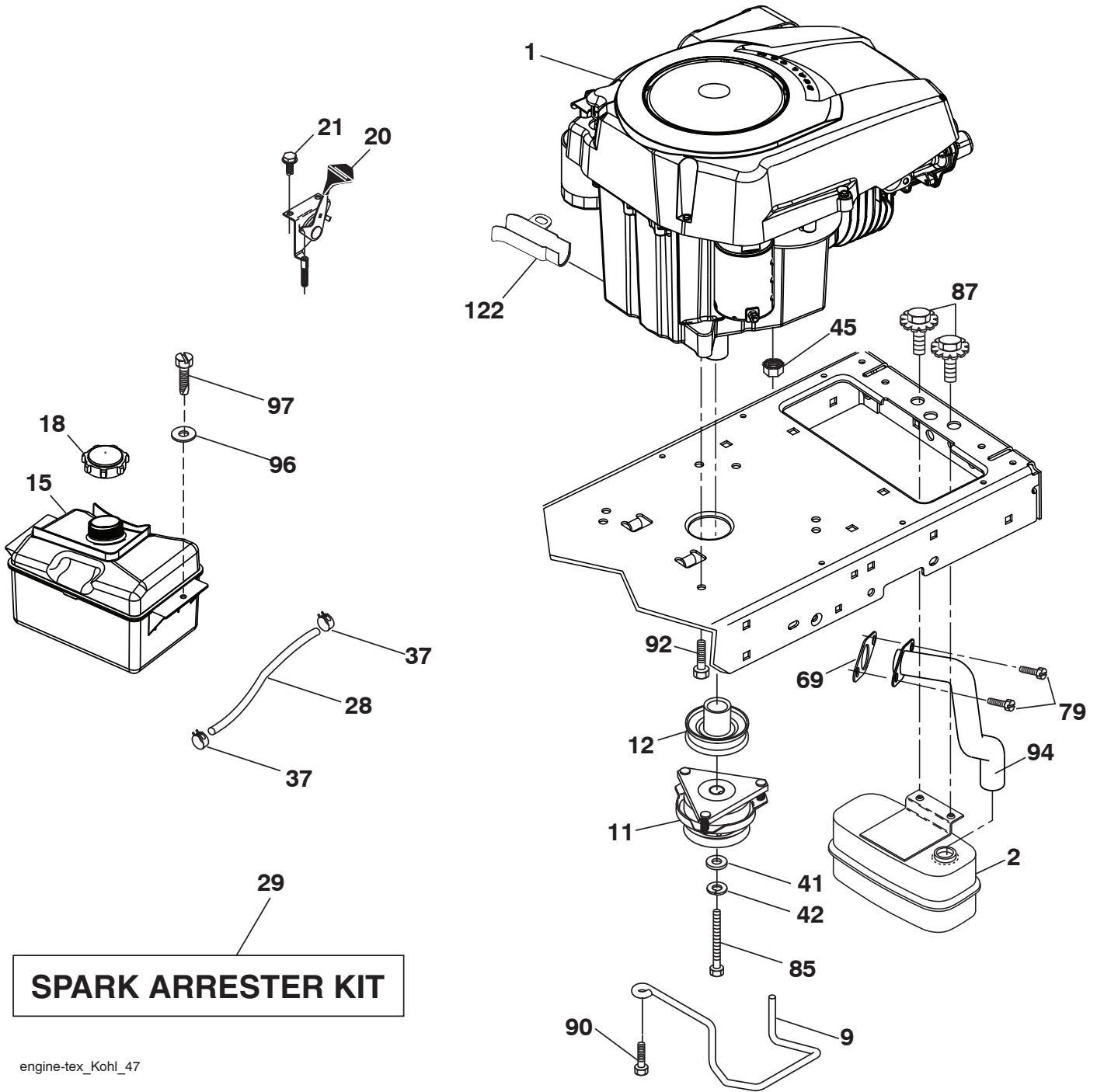

engine-tex_Kohl_47

**TRACTOR - - MODEL NO. LTH154 (96041024201), PRODUCT NO. 960 41 02-42
ENGINE 24**

KEY NO.	PART NO.	DESCRIPTION
1	-----	Engine Kohler Model No. SV470-3212 (438330) (Order parts from engine manufacturer.)
2	580 53 23-01	Muffler
9	532 19 43-20	Keeper Belt Engine
11	532 18 05-05	Clutch Ogura
12	532 40 50-97	Pulley Engine
15	581 28 99-01	Tank Fuel 1.5
18	532 43 02-20	Cap Fuel
20	532 18 38-97	Control Throttle
21	532 41 63-58	Screw #10 x .750 BOS Thread
28	532 13 70-40	Fuel Line
29	532 13 71-80	Spark Arrester Kit
37	532 12 34-87	Clamp Hose
41	532 12 61-97	Washer 1-1/2 x 15/32 x .250
42	810 04 07-00	Washer
45	873 51 04-00	Nut Keps Hex 1/4-20 unc
69	532 18 59-09	Gasket
79	532 19 23-34	Screw Socket 5/16-18 x .75
85	532 17 39-37	Bolt Hex 7/16-20 x 4 x Gr. 5-1.5
87	532 17 18-77	Bolt 5/16-18 unc x 3/4 w/Sems
90	817 00 06-16	Screw 3/8-16 x 1
92	817 12 06-16	Screw 3/8-16 x 1
94	532 18 86-54	Tube Exhaust
96	819 09 14-16	Washer 9/32 x 7/8 x 16 Ga.
97	817 67 04-12	Screw Hexwsh Thdrol 1/4-20 x 3/4
122	532 42 19-22	Extension Drain Oil

NOTE: All component dimensions given in U.S. inches
1 inch = 25.4 mm

TRACTOR - - MODEL NO. LTH154 (96041024201), PRODUCT NO. 960 41 02-42
STEERING ASSEMBLY **41**

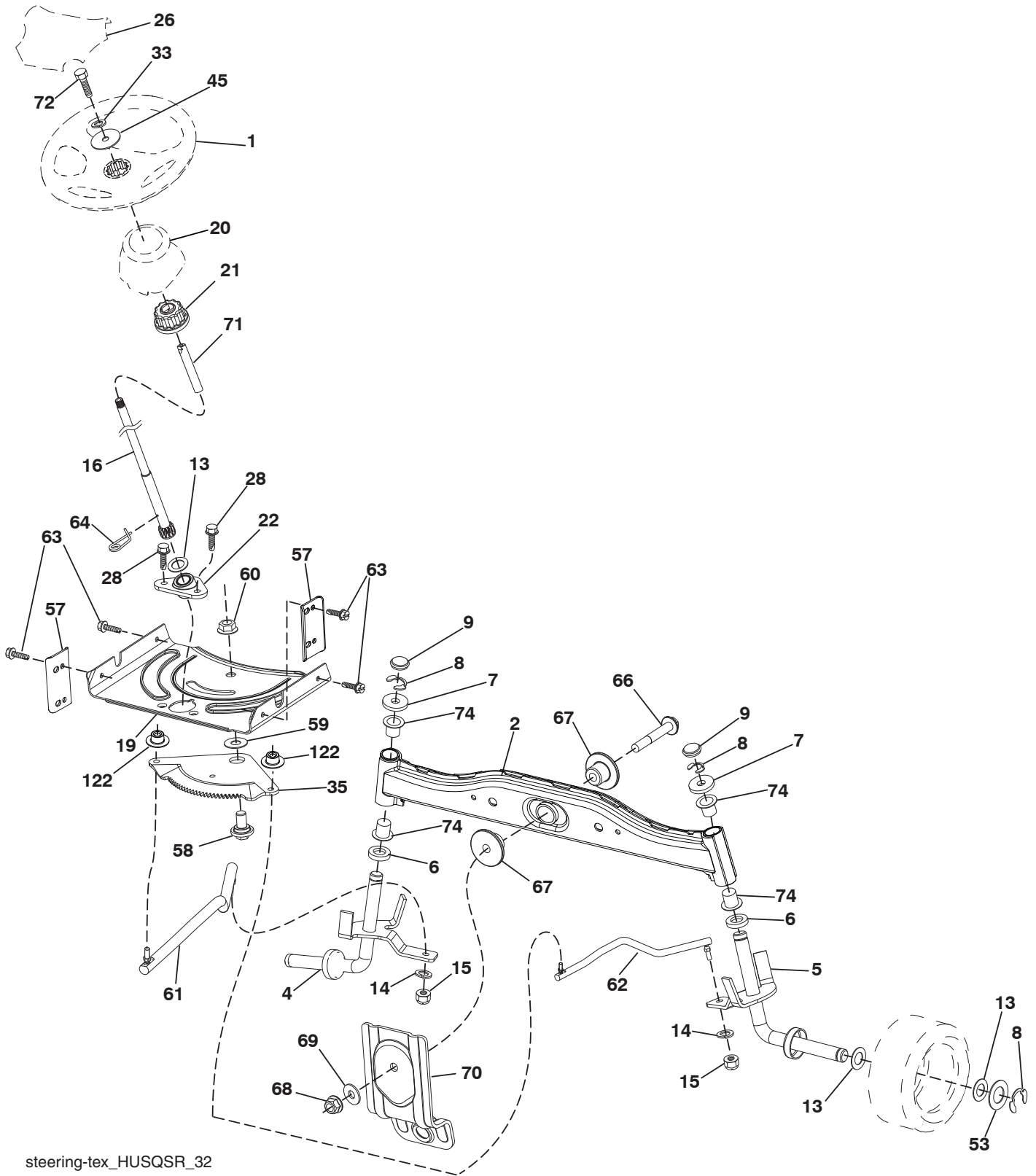

steering-tex_HUSQSR_32

**TRACTOR - - MODEL NO. LTH154 (96041024201), PRODUCT NO. 960 41 02-42
STEERING ASSEMBLY **41****

KEY NO.	PART NO.	DESCRIPTION
1	532 43 97-40	Wheel, Steering Husq SR
2	532 41 81-68	Axle Asm., Front
4	532 40 30-87	Spindle Asm., LH
5	532 40 30-88	Spindle Asm., RH
6	532 12 49-31	Bearing, Race Thrust Hardened
7	532 12 17-48	Washer 25/32 x 1-5/8 x 16 Ga.
8	812 00 00-29	Ring, Klip #T5304-75
9	532 12 12-32	Cap, Spindle
13	532 12 17-49	Washer, 25/32 x 1-1/4 x 16 Ga.
14	810 04 06-00	Washer, Lock Hvy Hlcl Spr 3/8
15	873 54 06-00	Nut, Crown Lock 3/8-24 unf
16	532 42 93-73	Shaft Steering
19	532 19 47-29	Plate Steering
20	532 44 14-25	Boot, Steering
21	532 18 67-37	Adapter, Wheel Steering
22	532 42 05-37	Steering Support Lower
26	532 43 97-43	Insert, Wheel Steering Husq SR
28	817 00 06-12	Screw 3/8-16 x 3/4
33	810 04 05-00	Washer Lock 5/16
35	532 19 47-32	Gear, Sector Plate
45	819 11 38-12	Washer 11/32 x 3/8 x 12 Ga.
53	532 18 89-67	WasherHardened.793x1.637x.060
57	532 40 74-65	Bracket Upstop
58	532 19 47-47	Bolt Shoulder Sector Pivot CFM
59	532 19 47-48	Washer Thrust Sector Steering
60	873 97 10-00	Nut Flange Lock 5/8-11
61	532 19 47-40	Draglink, LH
62	532 19 47-41	Draglink, RH
63	817 00 05-12	Screw 5/16-18 x 3/4
64	532 19 98-49	Retainer Clip Spring Steering
66	871 02 07-48	Bolt Hex Fghd 7/16-14 x 3 Serr
67	532 19 47-37	Bushing PM Front Axle
68	873 90 07-00	Nut Lock Flange 7/16-14 Gr. 5
69	532 19 91-62	Washer 1.5 x .505 x .118
70	532 19 61-97	Bracket Deck Susp. Front
71	532 19 07-52	Shaft Extension Steering
72	532 42 89-82	Bolt 5/16-18 unc x 4 w/Patch
74	532 12 49-37	Bearing
122	532 44 49-62	Cap Gear Sector

NOTE: All component dimensions given in U.S. inches
1 inch = 25.4 mm

**TRACTOR - - MODEL NO. LTH154 (96041024201), PRODUCT NO. 960 41 02-42
MOWER DECK 44**

KEY NO.	PART NO.	DESCRIPTION
1	532 44 41-63	Mower Housing
6	532 19 51-86	Arm Suspension
8	532 19 30-03	Bolt/Washer asm 7/16-20 unf
11	532 19 39-57	Blade, Premium, (For better wear when mulching) 38" 3NI
13	532 19 28-72	Shaft Assembly, Mandrel
14	532 18 72-81	Housing, Mandrel
15	532 11 04-85	Bearing, Ball, Mandrel
19	532 19 65-39	Bolt, Shoulder
21	873 68 05-00	Nut, Crownlock 5/16-18 unc
23	532 19 25-57	Bracket, Deflector
24	532 10 53-04	Cap, Sleeve
25	532 19 70-26	Spring, Torsion, Deflector
26	532 11 04-52	Nut, Push
27	532 40 14-72	Shield, Deflector
29	532 13 14-91	Rod, Hinge
30	532 17 39-84	Screw Thdrol Rolling Wsh Hd
31	532 18 76-90	Washer, Spacer
32	532 15 35-32	Pulley, Mandrel
33	532 40 02-34	Nut, Toplock, Flanged
34	872 11 06-12	Bolt Carr Sh. 3/8-16 x 1-1/2 Gr. 5
40	873 90 06-00	Nut, Lock Flg. 3/8-16 unc
55	532 19 72-49	Arm, Idler
56	532 19 90-92	Spacer Retainer
57	817 00 06-16	Screw 3/8-16 x 1
59	532 14 10-43	Guard, Tuv Idler
68	532 44 75-59	V-Belt
69	872 14 05-05	Bolt
115	872 11 05-05	Bolt Carr 5/16-18 x 5/8
144	532 19 34-14	Keeper Belt
145	532 19 31-97	Pulley, Idler, Flat
147	532 19 72-51	Spring Return
188	532 19 51-61	Stud Fastener
189	873 90 05-00	Nut Lock Hex Flange
199	532 40 00-95	Baffle Vortex
209	819 13 32-10	Washer 13/32 x 2 x 10
241	532 15 29-27	Screw
242	532 41 55-98	Port Washout
251	532 43 60-87	Kit
- -	532 19 28-70	Mandrel Assembly (Includes housing, shaft assembly, and bearing only - pulley/nut/washer and blade bolt/washers not included)
- -	580 30 45-01	Replacement Mower, Complete

NOTE: All component dimensions given in U.S. inches
1 inch = 25.4 mm

**TRACTOR - - MODEL NO. LTH154 (96041024201), PRODUCT NO. 960 41 02-42
MOWER DECK 44**

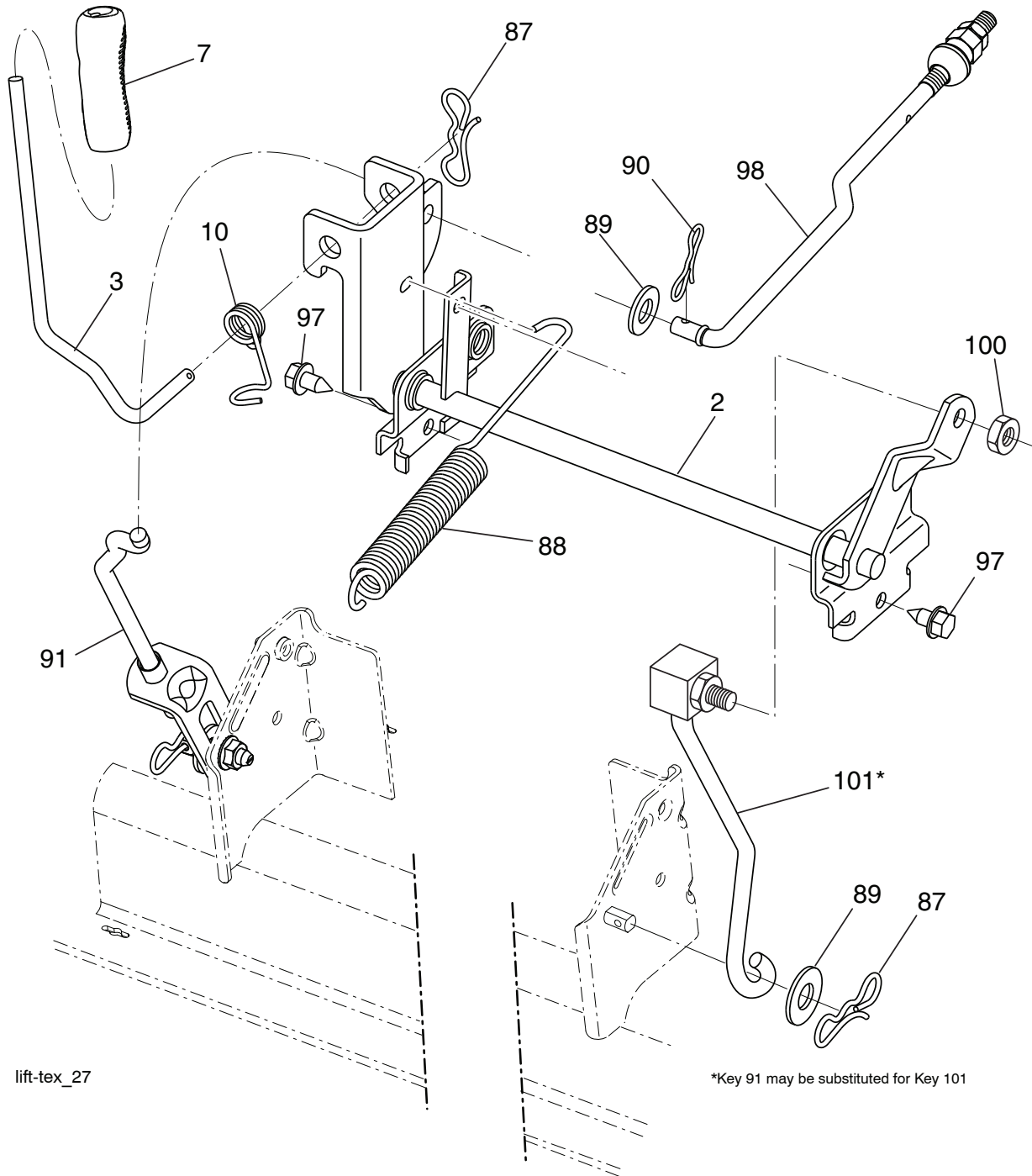

lift-tex_27

*Key 91 may be substituted for Key 101

KEY NO.	PART NO.	DESCRIPTION
2	532 42 20-27	Shaft Asm., Lift
3	532 19 52-31	Lever Asm., Lift RH
7	580 96 23-01	Grip, Lever
10	532 19 63-14	Spring Torsion
87	532 19 42-09	Pin Cotter 7/16 Bow Tie Lock
88	532 41 07-10	Spring Lift Assist.
89	819 19 19-12	Washer Clear Zinc
90	532 19 42-08	Pin Cotter 5/16 Bow Tie Lock

KEY NO.	PART NO.	DESCRIPTION
91	532 19 51-81	Link Lift Susp Mower Rear
97	817 00 06-12	Screw 3/8-16 x .75
98	532 19 52-70	Link Lift Susp. Front Mower
100	873 93 06-00	Nut Centerlock 3/8-16
101	532 40 70-03	Link Asm. Lift FXD

NOTE: All component dimensions given in U.S. inches
1 inch = 25.4 mm

**TRACTOR - - MODEL NO. LTH154 (96041024201), PRODUCT NO. 960 41 02-42
SEAT ASSEMBLY 42**

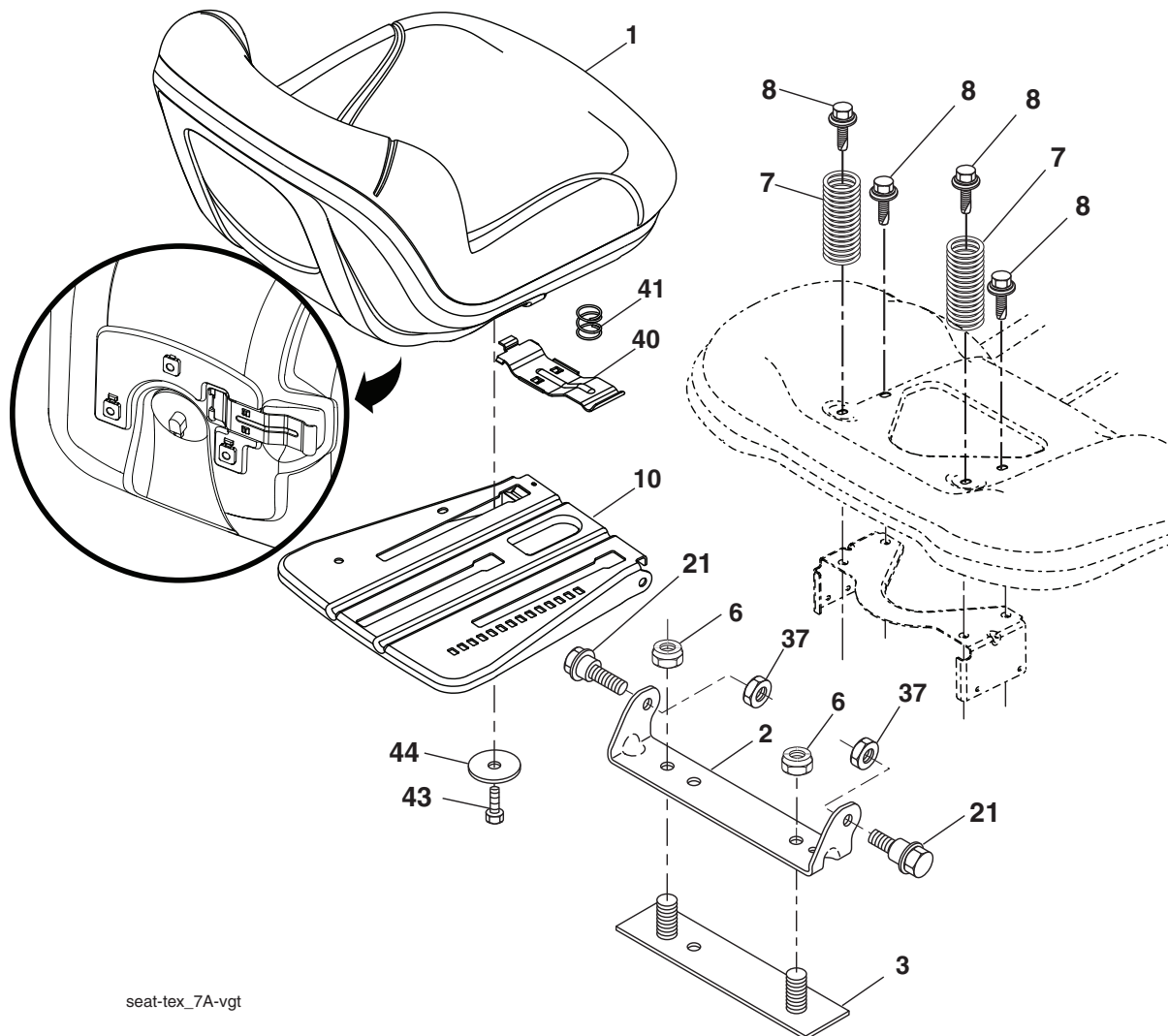

seat-tex_7A-vgt

KEY NO.	PART NO.	DESCRIPTION
1	532 43 98-19	Seat
2	532 18 01-66	Bracket Pivot Fender
3	532 14 06-75	Strap, Asm Fender
6	873 80 06-00	Nut, Lock W/Ins. 3/8-16 unc
7	532 12 41-81	Spring, Seat Cprsn
8	532 17 18-77	Bolt 5/16-18 unc x 3/4 w/Sems
10	532 19 69-77	Pan, Seat
21	532 17 18-52	Bolt, Shoulder 5/16-18
37	873 80 05-00	Nut, Lock 5/16-18 unc

KEY NO.	PART NO.	DESCRIPTION
40	532 19 76-61	Handle Slide
41	532 19 82-00	Spring Latch
43	874 76 06-12	Bolt Fin Hex 3/8-16 unc x 3/4
44	819 13 38-12	Washer 13/32 x 2-3/8 x 12 Ga.

NOTE: All component dimensions given in U.S. inches
1 inch = 25.4 mm

