

ILLUSTRATED PARTS LIST

MFG. ID NO. 96051003600

CUSTOMER CATALOG NO. CTH 224T

PRODUCT NO. 960 51 00-36

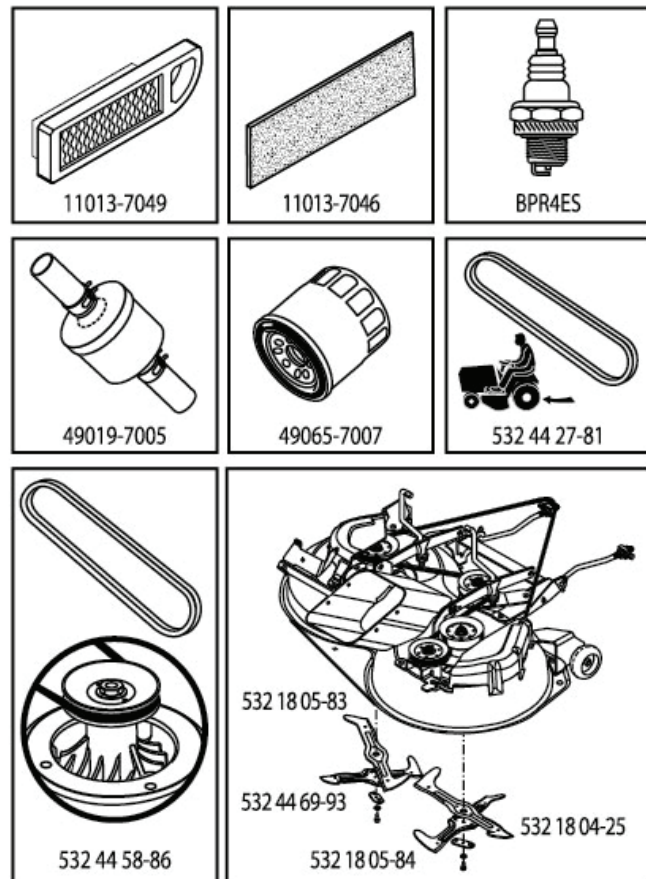

47

446090

TRACTOR - MODEL NO. CTH224T (96051003600), PRODUCT NO. 96051 00-36
DECALS 27

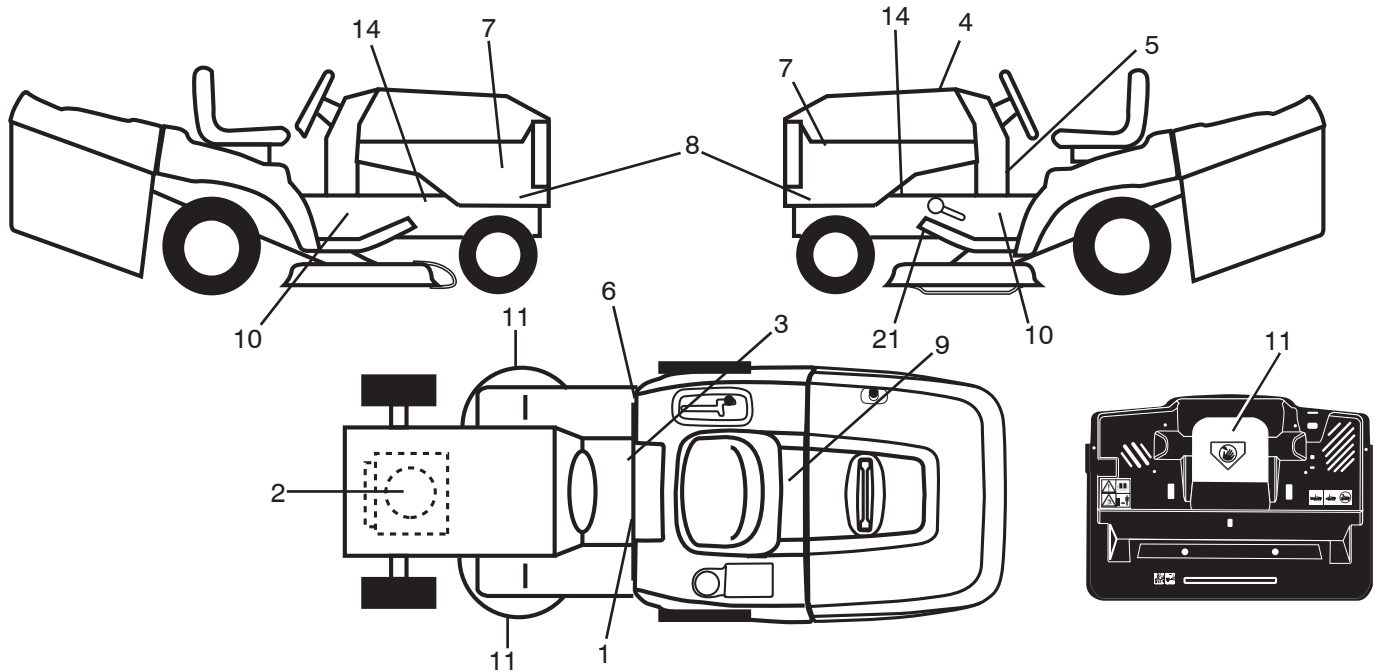

KEY NO.	PART NO.	DESCRIPTION
1	532 44 55-03	Decal, Warn Combined
2	532 19 68-41	Decal, Warning Eng. Sym.
3	532 17 83-02	Decal, Operator Cruise Symbol
4	532 44 60-90	Decal, Replacement
5	532 42 58-75	Decal, Lower Dash
6	532 18 04-32	Decal, 100 DBA
7	532 42 91-96	Decal, Hood
8	532 44 71-60	Decal, Side Panel

KEY NO.	PART NO.	DESCRIPTION
9	532 43 26-41	Decal, Warning CRD
10	532 40 11-46	Decal, Warning
11	532 18 21-66	Decal, Mower Cut Finger Symbol
14	532 15 97-36	Decal, Chassis Hot Muffler
21	532 44 11-89	Decal, Belt Schematic
--	532 44 14-09	Pad Footrest LH
--	532 44 14-10	Pad Footrest RH
--	580 41 62-40	Manual Operator's (Euro)

WHEELS AND TIRES

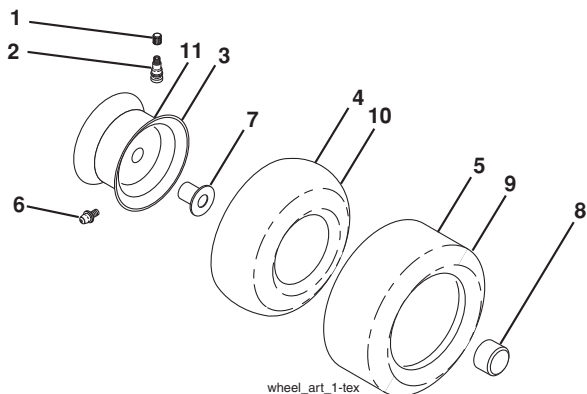

KEY NO.	PART NO.	DESCRIPTION
1	532 05 91-92	Cap Valve Tire
2	532 06 51-39	Stem Valve
3	532 13 83-36	Rim Front
4	532 05 99-04	Tube Front (Service Item Only)
5	532 10 62-22	Tire Front 15 x 6.0-6
6	532 12 49-57	Fitting Grease (Front Wheel Only)
7	532 12 49-59	Bearing Flange (Front Wheel Only)
8	532 17 50-39	Cap Axle Blk 1 50 x 1 00
9	532 42 05-31	Tire R 18 x 9.5-8
10	532 12 49-26	Tube Rear (Service Item Only)
11	532 13 83-37	Rim Asm 8" Rear
--	532 14 43-34	Sealant, Tire (10 oz. Tube)

NOTE: All component dimensions given in U.S. inches
 1 inch = 25.4 mm

TRACTOR - MODEL NO. CTH 224T (96051003600), PRODUCT NO. 960 51 00-36

SCHEMATIC 38

SCH25

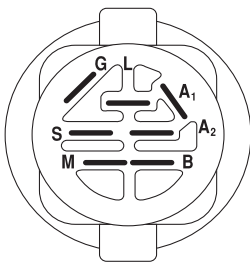
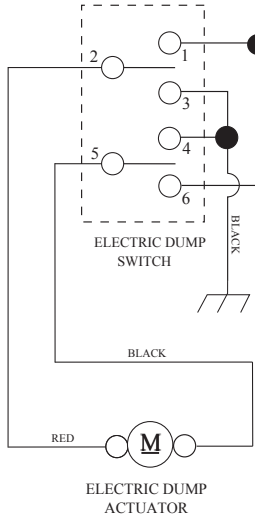
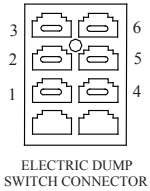
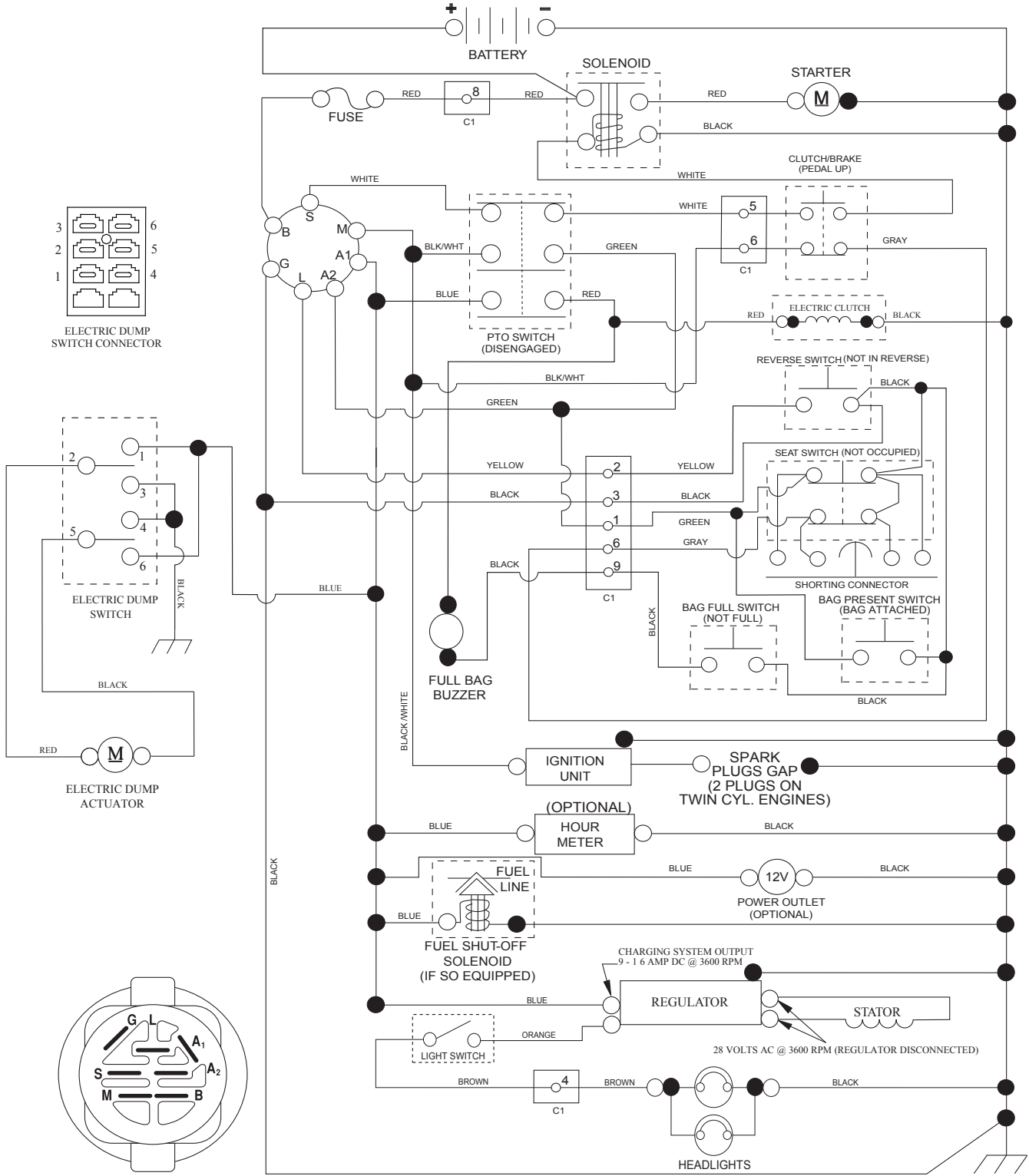

POSITION	CIRCUIT	"MAKE"
OFF	M+G+A1	
RUN/OVERRIDE	B+A1	
RUN	B+A1	L+A2
START	B + S + A1	

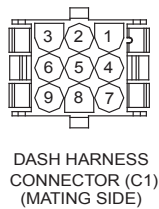

WIRING INSULATED CLIPS
NOTE: IF WIRING INSULATED CLIPS WERE REMOVED FOR SERVICING OF UNIT, THEY SHOULD BE RE-INSTALLED TO PROPERLY SECURE YOUR WIRING.

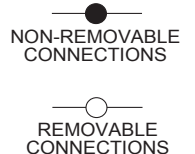

TRACTOR - MODEL NO. CTH224T (96051003600), PRODUCT NO. 96051 00-36
ELECTRICAL 32

TC10S

With Service Minder Option

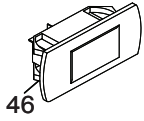

With Charge Indicator Option

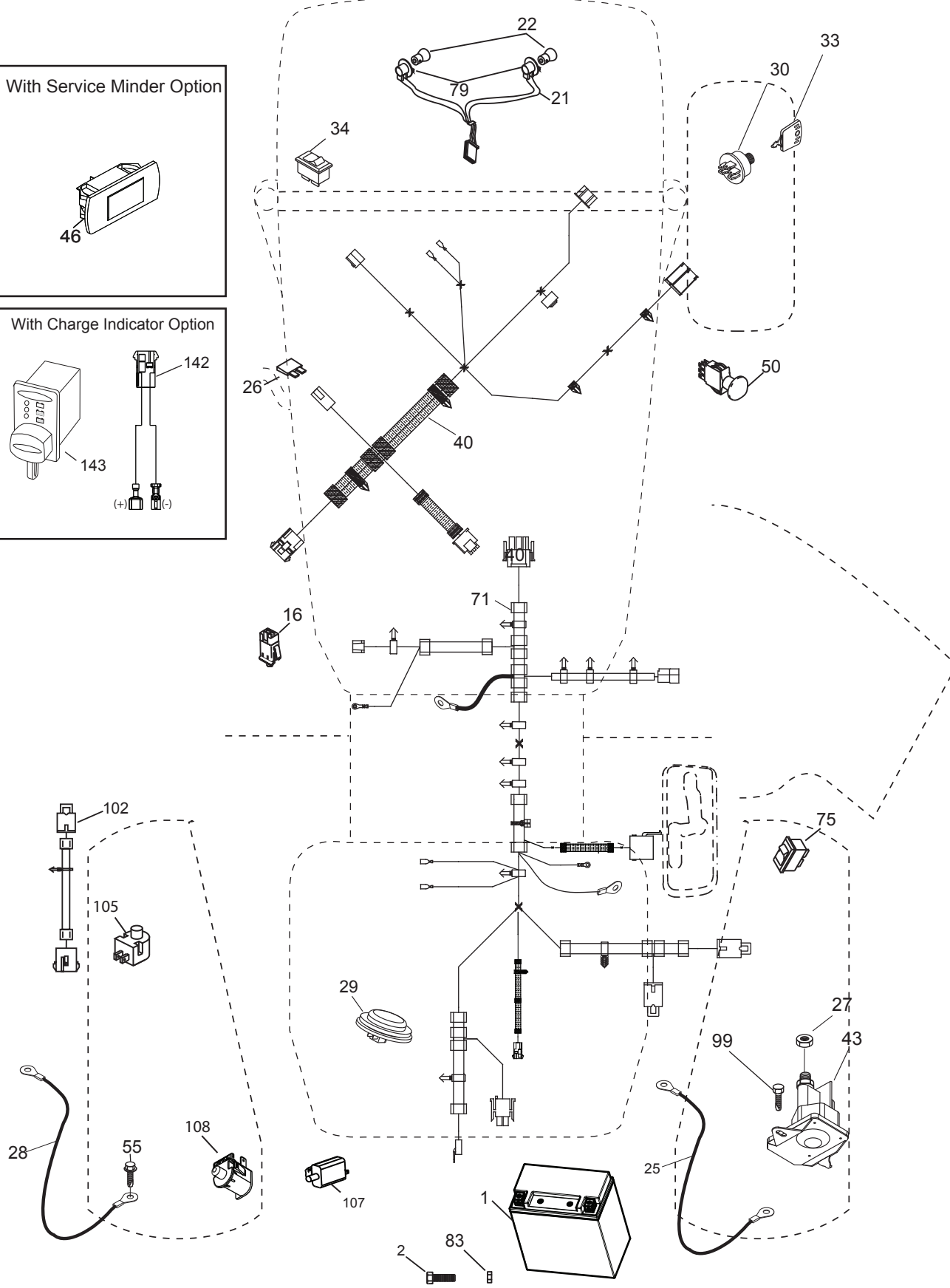
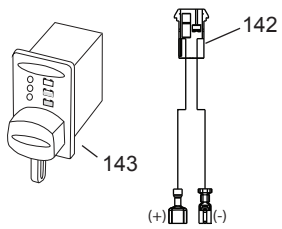

TRACTOR - MODEL NO. CTH 224T (96051003600), PRODUCT NO. 960 51 00-36
ELECTRICAL 32

KEY NO.	PART NO.	DESCRIPTION
1	532 43 71-57	Battery
2	532 44 09-23	Screw Hex Hd Cap M6 x 1.12MM
16	532 17 61-38	Switch Interlock Push-In
21	532 40 02-52	Harness Light w/4152J
22	532 00 41-52	Bulb Light
25	532 44 13-83	Cable Starter
26	532 17 51-58	Fuse
27	873 51 04-00	Nut Keps Hex 1/4-20 unc
28	532 44 18-32	Cable, Ground
29	532 40 15-45	Switch, Seat
30	532 19 33-50	Switch, Ign
33	532 41 19-35	Key/Chain
34	532 11 07-12	Switch Light/Reset
40	532 44 80-36	Harness Ign. Dash/Lift
43	532 19 25-07	Solenoid
46	532 40 17-63	Gauge Serviceminder Hrmtr
50	532 17 46-51	Switch PTO
55	817 06 05-12	Screw Thdrol 5/16-18 x 3/4 TYTT
71	580 68 89-01	Harness Ignition Chassis/Lift
75	532 44 45-34	Switch Bag Dump
79	532 17 52-42	Socket Asm. Bulb
83	532 43 67-74	Nut Square M6 x 1.8.5 x 11MM
99	817 72 04-08	Screw 1/4-20 x 1/2
102	532 44 12-62	Harness Jumper
105	532 40 75-68	Switch Reverse
107	532 18 03-79	Switch Full Bagger
108	532 42 10-62	Switch Snapmount
142	532 44 80-57	Harness Jumper CTEK

NOTE: All component dimensions given in U.S. inches
1 inch = 25.4 mm

TRACTOR - MODEL NO. CTH224T (96051003600), PRODUCT NO. 96051 00-36
CHASSIS AND ENCLOSURES 39

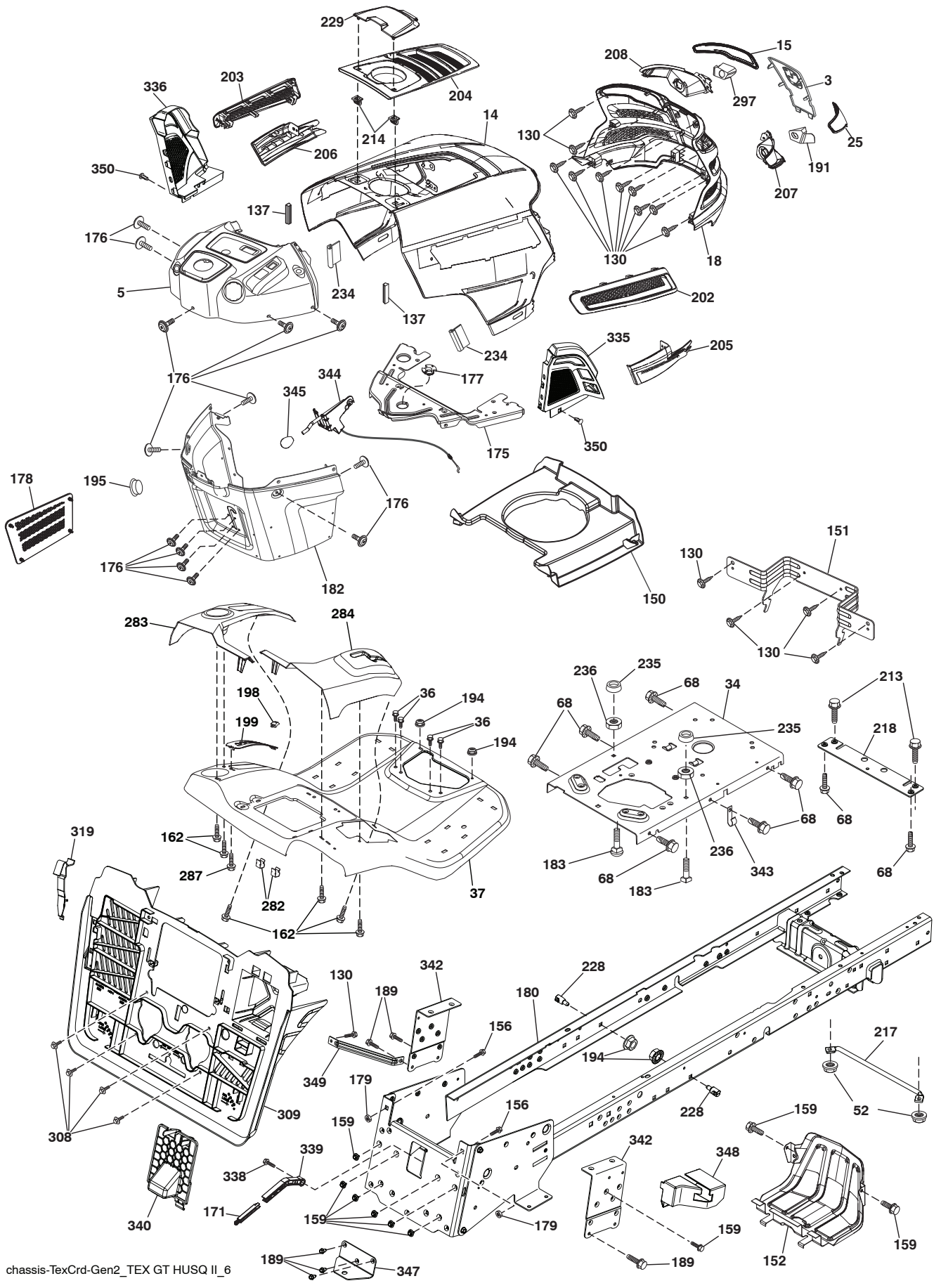

chassis-TeXCrd-Gen2_TEX GT HUSQ II_6

**TRACTOR - MODEL NO. CTH 224T (96051003600), PRODUCT NO. 960 51 00-36
CHASSIS AND ENCLOSURES 39**

KEY NO.	PART NO.	DESCRIPTION	KEY NO.	PART NO.	DESCRIPTION
3	532 43 97-52	Applique	207	532 43 97-34	Bezel RH
5	532 43 74-84	Dash	208	532 43 97-35	Bezel LH
14	532 44 11-77	Hood	213	874 76 05-12	Bolt 5/16-18 x 3/4
15	532 43 97-33	Lens LH	214	532 19 91-45	Clip Retainer Tinner
18	532 44 06-53	Grille	217	532 40 91-67	Rod Pivot
25	532 44 33-85	Lens RH	218	532 19 63-95	X-Piece Hood Stop
34	532 44 72-53	Plate Engine	228	532 19 51-61	Stud Fastner
36	817 06 05-12	Screw 5/16-18 x 3/4	229	532 44 14-63	Lid Ext
37	532 44 13-69	Fender	234	532 40 47-42	Bumper Hood
52	873 68 05-00	Nut Lock 5/16-18	235	532 40 61-29	Spacer Fender
68	817 49 05-08	Screw Thdrol 5/16-18 x 1/2	236	873 93 05-00	Nut Lock 5/16-18 unc
130	532 41 63-58	Screw #10 x 0.750	282	532 41 41-10	Clip Retainer
137	532 40 75-90	Bumper Dash	283	532 44 72-12	Console Deck Lift LH
150	532 43 97-74	Air Duct	284	532 44 73-17	Console Shft RH
151	532 43 66-70	Bracket Pivot	287	817 60 04-06	Screw 1/4-20 x 3/8
152	532 43 98-70	Shield Browning	297	532 43 74-56	Insert Reflective LH
156	872 14 06-14	Bolt 3/8-16 x 1-3/4	308	532 17 18-77	Bolt 5/16-18 unc x 3/4
159	817 00 06-12	Screw Hexwsh Thrd 3/8-16 x 3/4	309	532 44 77-79	Backplate
162	532 14 24-32	Screw	319	532 44 68-76	Lever Bag Presence
171	532 44 12-89	Extension Bagger Full	335	532 44 53-09	Cover RH Lower Close Out
175	532 19 63-04	Crossmember	336	532 44 82-04	Cover LH Lower Close Out
176	532 40 07-76	Screw 10-24 x 5/8	338	532 43 66-40	Bolt Shoulder
177	532 19 52-27	Bushing Steering	339	532 44 12-88	Lever Bagger Full
178	532 19 97-82	Cargo Asm. Net	340	532 44 74-78	Door Battery
179	532 16 89-37	Nut Push	342	532 43 59-38	Supprt Fender
180	583 90 27-01	Chassis	343	532 44 07-49	Clip
182	532 43 89-67	Dash Lower	344	532 43 89-70	Control EZ Mulch
183	874 52 05-20	Bolt 5/16-18 x 1-1/4	345	532 44 06-39	Knob
189	817 00 05-12	Screw 5/16-18 x 3/4	347	532 44 28-87	Hitch Tow
191	532 43 74-55	Insert Reflective RH	348	532 44 49-26	Solenoid Cover
194	873 90 05-00	Nut Lock Hex Flange 5/16-18	349	532 43 66-06	Bracket Support
195	532 40 41-37	Plug Hole Dash Lower	350	532 44 51-43	Clip X-Mas Tree
198	532 44 15-52	Indicator Deck Lift			
199	532 41 87-39	Plate Deck Lift			
202	532 43 97-28	Vent Side Hood RH			
203	532 43 97-27	Vent Side Hood LH			
204	532 44 06-65	Vent Top Hood			
205	532 43 97-30	Skirt Hood Side RH			
206	532 43 97-29	Skirt Hood Side LH			

NOTE: All component dimensions given in U.S. inches
1 inch = 25.4 mm

TRACTOR - MODEL NO. CTH224T (96051003600), PRODUCT NO. 96051 00-36
DRIVE 40

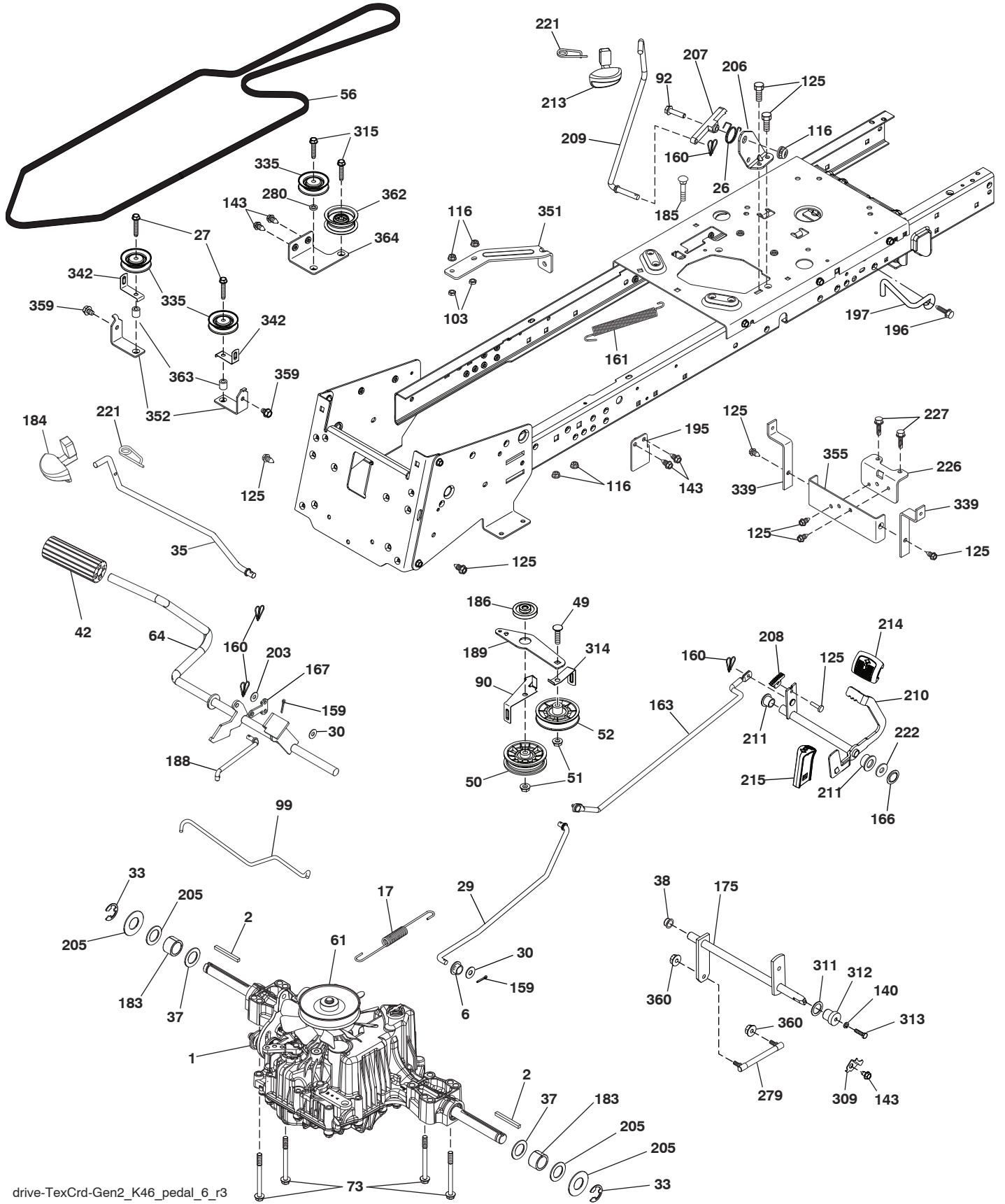

drive-TexCrd-Gen2_K46_pedal_6_r3

**TRACTOR - MODEL NO. CTH 224T (96051003600), PRODUCT NO. 960 51 00-36
DRIVE 40**

KEY NO.	PART NO.	DESCRIPTION	KEY NO.	PART NO.	DESCRIPTION
1	-----	Transaxle, TUFFTORQ K46DF (446488) (Order parts from trans- axle manufacturer.)	189	532 43 36-11	Bellcrank Ground Drive
2	532 12 35-83	Key Square	195	532 43 58-65	Bracket Rod Brake CRD Tex
6	532 12 40-28	Bushing Snap	196	817 00 06-16	Screw 3/8-16 x 1 Smgml Tap/R Blk
17	532 43 62-27	Spring Brake K46	197	532 19 58-04	Link Clutch Anti-Rotation
26	532 19 96-79	Spring Return Cruise	203	819 11 11-16	Washer 11/32 x 11/16 x 16 Ga.
27	817 49 05-28	Screw Hexwsh Thd 5/16-18 x 1-3/4	205	532 12 17-48	Washer 25/32 x 1-5/8 x 16 Ga.
29	532 44 27-95	Rod, Brake	206	532 19 78-67	Bracket Mount Latch Cruise
30	819 13 16-16	Washer	207	532 19 78-68	Latch Control Cruise
33	812 00 00-01	Ring E	208	532 19 78-69	Gear Sector Control Cruise
35	583 86 45-01	Rod, Brake, Park	209	532 19 95-92	Rod Control Cruise
37	532 18 89-67	Washer Harden 793 x 1063 x 060	210	532 40 09-80	Rocker Asm. Pedal Control
38	532 16 96-13	Nyliner Bushing	211	532 12 01-83	Bearing Nylon
42	532 12 48-72	Cover, Foot Pedal	213	532 40 31-19	Knob Control Cruise
49	872 11 06-14	Bolt Rdhd 3/8-16 unc x 3/4 Gr. 5	214	532 42 12-63	Pedal Forward
50	532 19 43-27	Idler Flat	215	532 41 94-82	Pedal Reverse
51	873 90 06-00	Lock Nut 3/8-16	221	532 40 31-87	Retainer Spring Clip Handle
52	532 19 43-26	Idler V-Groove	222	879 21 20-10	Washer 21/32 x 1-1/4 10 Ga.
56	532 44 27-81	V-Belt, Drive	226	532 40 15-64	Bracket Strap Torque
61	532 44 51-51	Pulley Transaxle K46	227	817 49 05-12	Screw
64	532 19 78-65	Shaft Asm. Pedal Brake Control	279	532 44 42-83	Link Shift
73	874 49 05-44	Bolt Flanged	280	819 11 10-12	Washer 11/32 x 5/8 x 12 Ga.
90	532 44 36-05	Keeper Belt Clutching	309	532 16 55-81	Plate Fstnr Cross Shf
92	874 76 05-20	Bolt Fin Hex 5/16-18 unc x 1.25	311	532 16 98-45	Washer Nylon
99	532 44 39-47	Rod Spring Bypass	312	532 16 56-14	Hub Tapered
103	873 35 05-00	Nut Hex Jam 5/16-18	313	874 78 04-16	Bolt Hex Fin 1/4-20 unc x 1 Gd5
116	873 90 05-00	Nut Lock Hex Flange 5/16-18	314	532 44 47-13	Keeper Belt
125	817 00 05-12	Screw 5/16-18 x 3/4	315	817 58 05-20	Screw Thdrol 5/16-18 x 4.25
140	810 04 04-00	Washer Lock Hvy Helical 1/4	335	532 19 95-34	Pulley V-Idler
143	817 49 05-08	Screw 5/16-18 x 1/2	339	532 43 68-67	Strap Torque K46 CRD Tex
159	876 02 04-12	Pin Cotter 1/8 x 3/4	342	532 18 26-82	Keeper Belt 2.5" STL V-Idlr CRD
160	532 16 94-84	Retainer Clip	351	532 43 69-98	Bracket 97 CRD Deck Sway
161	532 10 57-09	Spring, Return, Clutch	352	532 43 56-45	Bracket Idler CRD Tex
163	532 44 27-93	Rod Control	355	532 43 56-69	Bracket
166	532 42 91-64	Nut Push	359	817 49 06-10	Screw Thdrol 3/8-16 x 5/8
167	532 40 52-57	Latch Brake Parking	360	532 44 47-14	Nut 5/16-24 UNF
175	532 42 93-59	Shaft Asm Crossshift Rear Crd	362	532 43 68-12	Idler Flat
183	532 13 70-57	Spacer Axle	363	532 44 27-80	Spacer 343 x 63 x .62
224	532 44 14-55	Handle Parking Brake	364	532 44 30-32	Bracket Idler CRD Tex
185	872 11 06-22	Bolt 3/8-16 unc x 2-3/4 G5			
186	532 19 43-21	Spacer Retainer			
188	532 19 43-23	Link Clutch			

NOTE: All component dimensions given in U.S. inches
1 inch = 25.4 mm

TRACTOR - MODEL NO. CTH224T (96051003600), PRODUCT NO. 96051 00-36
ENGINE **24**

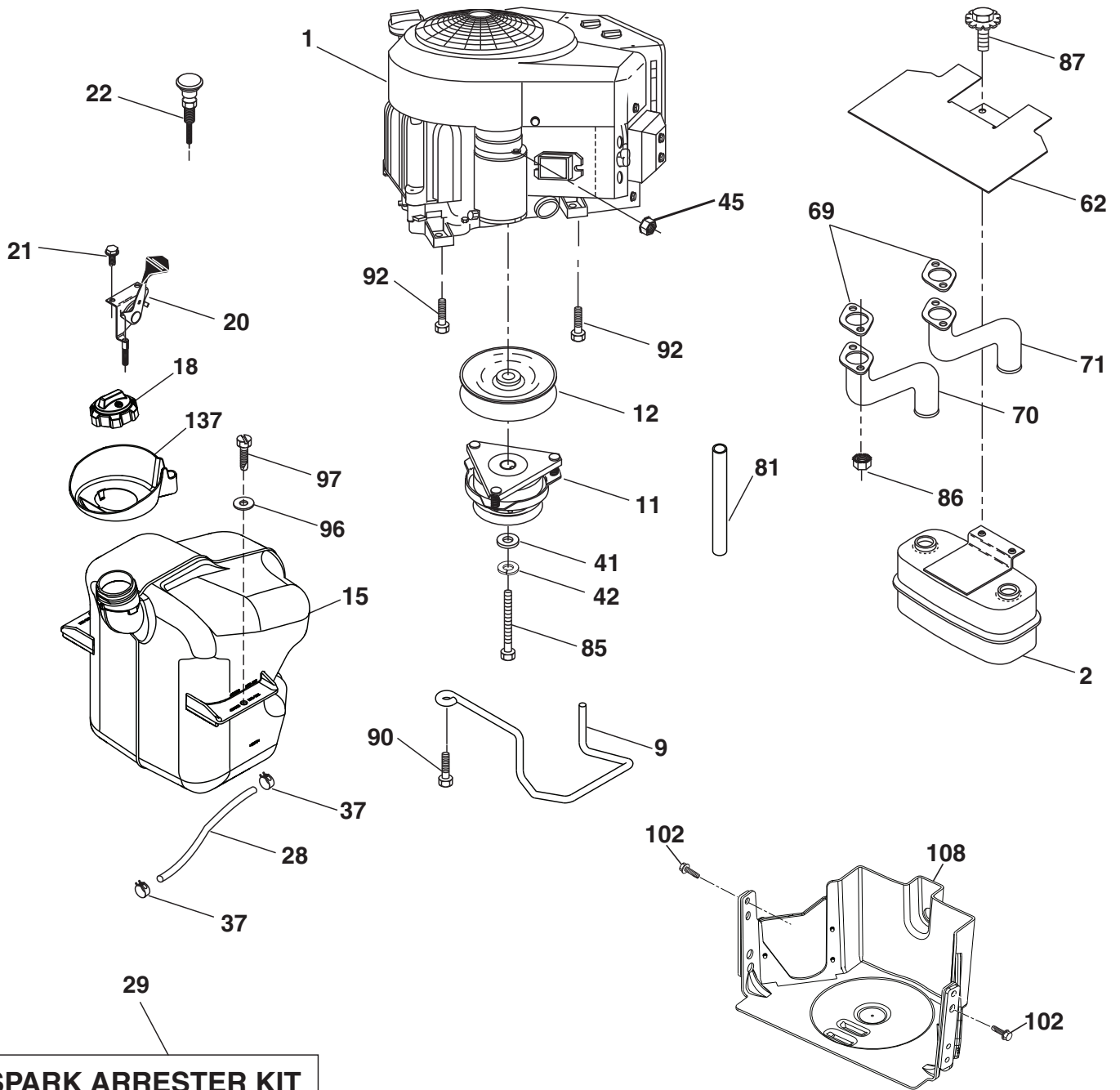

SPARK ARRESTER KIT

engine-tex_Kawa-2cyl_19

**TRACTOR - MODEL NO. CTH 224T (96051003600), PRODUCT NO. 960 51 00-36
ENGINE 24**

KEY NO.	PART NO.	DESCRIPTION
1	-----	Engine Kawasaki Model No. FS651V-BS50 (445368) (Order parts from engine manufacturer.)
2	532 44 59-62	Muffler
9	532 19 43-20	Keeper Belt Engine
11	532 40 00-08	Clutch Electric
12	532 40 50-97	Pulley Engine
15	532 43 58-16	Tank Fuel
18	532 44 14-62	Fuel Cap
20	532 41 21-65	Control Throttle
21	532 41 63-58	Screw # 10 x 0.750
22	532 18 95-41	Control Choke
28	532 13 70-40	Fuel Line
29	532 13 71-80	Spark Arrester Kit
37	532 12 34-87	Clamp Hose
41	532 12 61-97	Washer 1-1/2 OD x 15/32 ID x .250
42	810 04 07-00	Washer Lock 7/16
45	873 51 04-00	Nut Keps Hex 1/4-20 unc
62	532 43 40-17	Shield Heat Muffler
69	532 17 81-51	Gasket
70	532 42 47-65	Tube Exhaust LH
71	532 42 47-66	Tube Exhaust RH
81	532 14 84-56	Tube Drain Oil Easy
85	532 17 39-37	Bolt Hex 7/16-20 x 4 x Gr. 5-1.5 Thr
86	532 18 43-62	Nut Hex Flange Toplock M8-1.25
87	532 17 18-77	Bolt 5/16-18 unc x 3/4 w/Sems
90	817 00 06-16	Screw 3/8-16 x 1
92	817 12 06-16	Screw 3/8-16 x 1
96	819 09 14-16	Washer 9/32 x 7/8 x 16 Ga.
97	817 67 04-12	Screw 1/4-20 x 3/4
102	817 06 05-16	Screw 5/16-18 x 1
108	532 42 30-41	Cover Pulley Engine
137	532 44 14-61	Spill Cup

NOTE: All component dimensions given in U.S. inches
1 inch = 25.4 mm

TRACTOR - MODEL NO. CTH224T (96051003600), PRODUCT NO. 96051 00-36
STEERING ASSEMBLY [41]

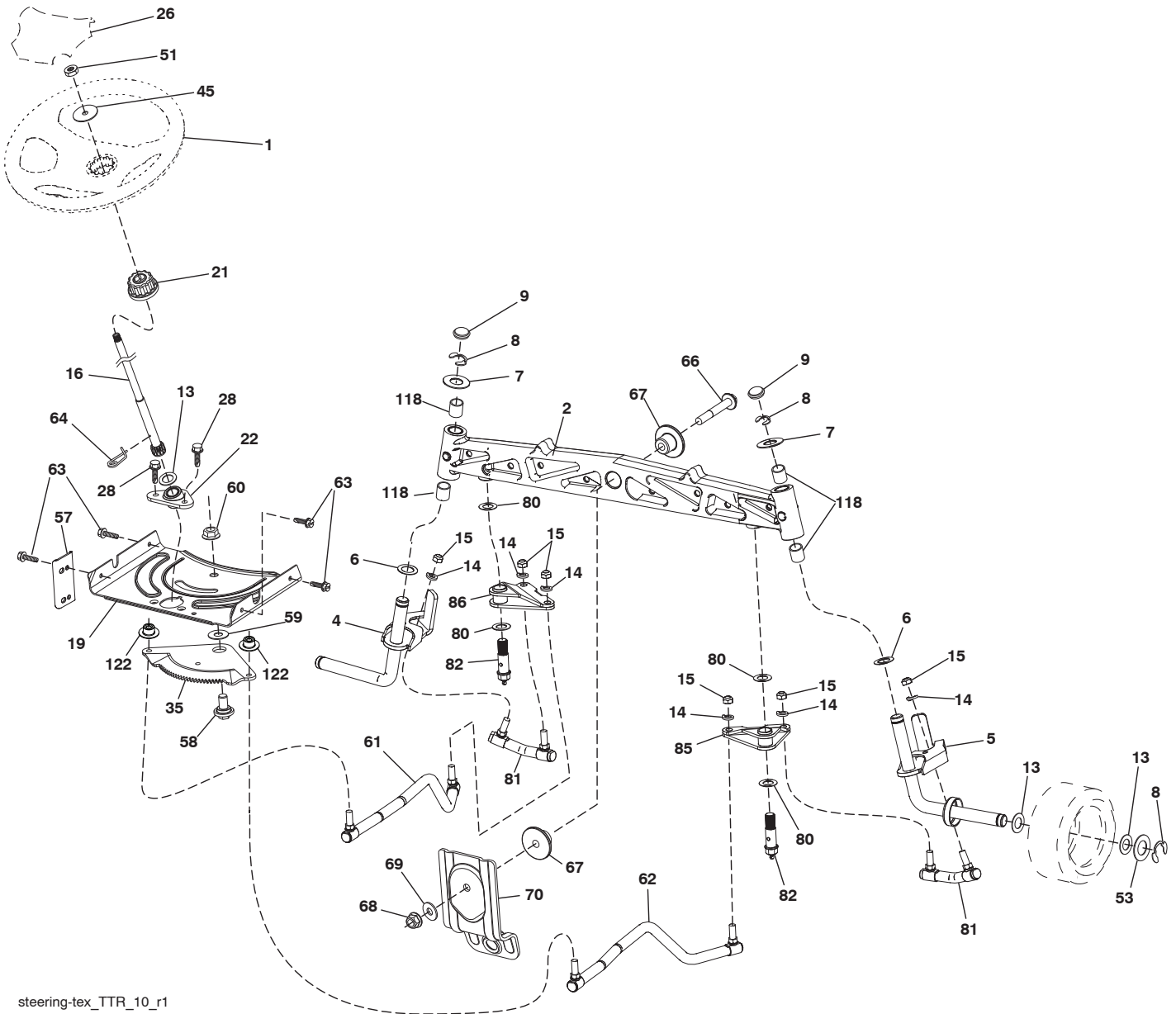

steering-tex_TTR_10_r1

TRACTOR - MODEL NO. CTH 224T (96051003600), PRODUCT NO. 960 51 00-36
STEERING ASSEMBLY 41

KEY NO.	PART NO.	DESCRIPTION
1	532 43 97-40	Wheel, Steering
2	532 43 68-70	Axle Asm., Front
4	532 43 68-73	Spindle Asm., LH
5	532 43 68-74	Spindle Asm., RH
6	532 12 49-31	Washer Thrust 0.75 x 1.23
7	532 12 17-48	Washer 25/32 x 1-5/8 x 16 Ga.
8	812 00 00-29	Ring, Klip #T5304-75
9	532 12 12-32	Cap, Spindle
13	532 12 17-49	Washer 25/32 x 1-1/4 x 16 Ga.
14	810 04 06-00	Washer, Lock 3/8
15	873 54 06-00	Nut, Crown Lock 3/8-24 unf
16	532 44 42-12	Shaft Steering
19	532 19 47-29	Plate Steering
21	532 43 77-47	Adapter, Wheel Steering
22	532 19 48-45	Bushing, Strg. Blk
26	532 43 97-43	Insert, Wheel Steering
28	817 00 06-12	Screw 3/8-16 x 3/4
35	532 44 07-70	Gear, Sector Plate
45	819 18 38-12	Washer 9/16 ID x 2-3/8 OD
51	873 94 08-00	Nut Hex Jam Toplock 1/2-20 UNF
53	532 18 89-67	Washer Hardened .793 x 1.637 x .060
57	532 40 74-65	Bracket Upstop
58	532 19 47-47	Bolt Shoulder Sector Pivot CFM
59	532 19 47-48	Washer Thrust Sector Steering
60	873 97 10-00	Nut Flange Lock 5/8-11
61	532 43 68-84	Draglink, LH
62	532 43 68-85	Draglink, RH
63	817 00 05-12	Screw 5/16-18 x 3/4
64	532 19 98-49	Retainer Clip Spring Steering
66	871 02 07-48	Bolt Hex Fghd 7/16-14 x 3 Serr
67	532 19 47-37	Bushing PM Front Axle
68	873 90 07-00	Nut Lock Flange 7/16-14 Gr. 5
69	532 19 91-62	Washer 1.5 x .505 x .118
70	532 19 61-97	Bracket Deck Susp. Front
80	532 00 13-70	Washer
81	532 43 68-87	Link Cross RH
82	532 43 68-77	Pivot Bolt
85	532 44 18-73	Pivot RH
86	532 44 18-72	Pivot LH
118	532 40 60-13	Bushing Axle
122	532 44 49-62	Cap Gear

NOTE: All component dimensions given in U.S. inches
1 inch = 25.4 mm

TRACTOR - MODEL NO. CTH224T (96051003600), PRODUCT NO. 96051 00-36
MOWER DECK 44

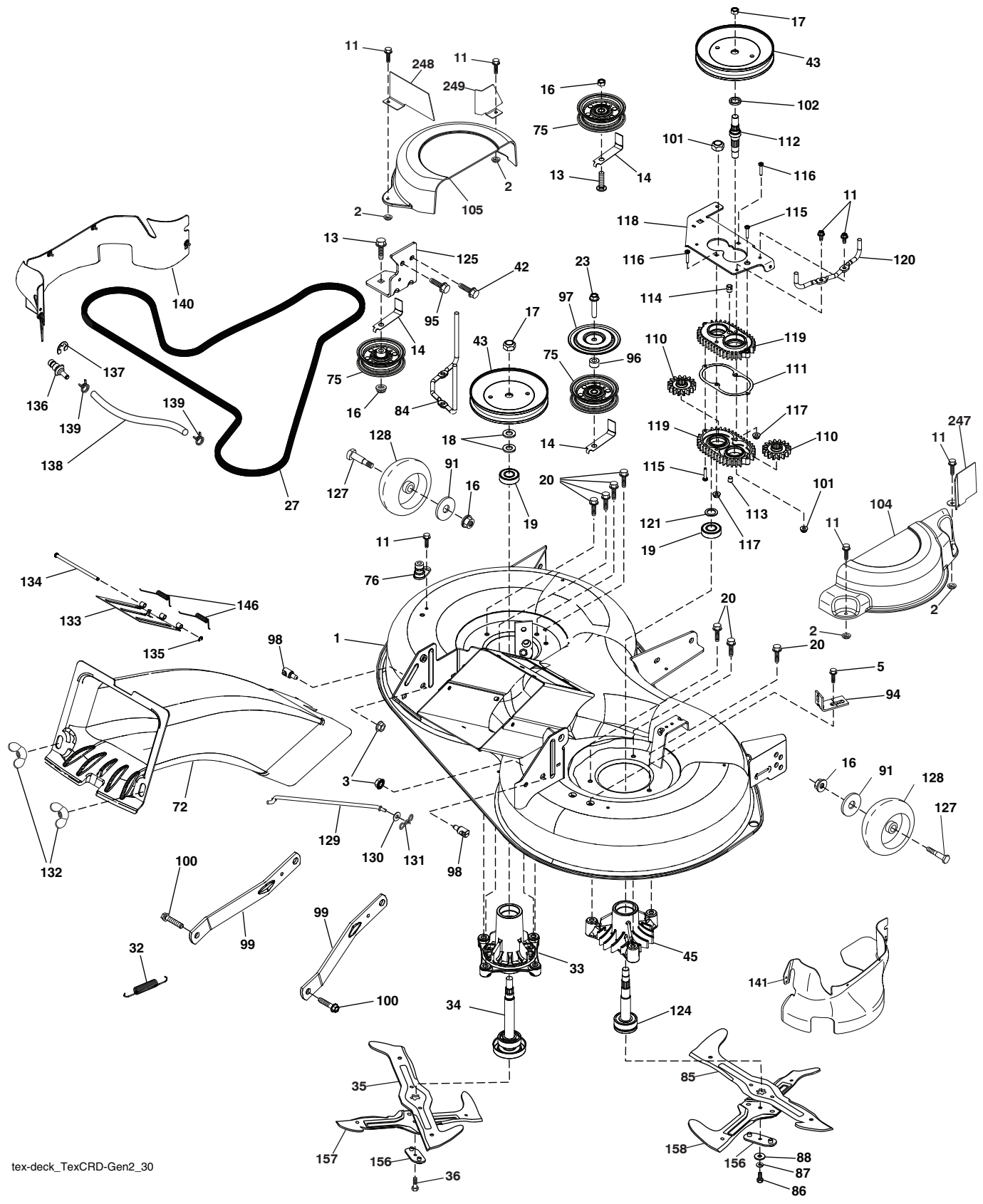

tex-deck_TexCRD-Gen2_30

TRACTOR - MODEL NO. CTH 224T (96051003600), PRODUCT NO. 960 51 00-36
MOWER DECK 44

KEY NO.	PART NO.	DESCRIPTION	KEY NO.	PART NO.	DESCRIPTION
1	532 44 82-09	Deck Weldment	111	532 43 69-79	Gasket Gearcase
2	532 42 30-62	Palnut 1/4	112	532 44 38-52	Shaft Gearcase
3	873 90 05-00	Nut Lock Hex Flange 5/16 - 18	113	532 43 85-33	Plug Oil
5	817 00 05-10	Bolt 5/16-18	114	532 43 85-34	Valve Relief
11	532 13 77-29	Screw Thd Roll 1/4 - 20 X 5/8	115	818 03 10-16	Screw Torx #10-24 x 1
13	872 11 06-12	Bolt Carr Sh 3/8 - 16 X 1 - 1/2 Gr. 5	116	872 11 04-14	Bolt 1/4-20 x 1.75 Gr. 5
14	532 15 60-85	Keeper Belt Idler	117	873 90 04-00	Nut Hex Flange 1/4-20 unc
16	873 90 06-00	Nut Lock FIG 3/8 - 16 unc	118	532 44 32-32	Arm Clutching
17	532 40 02-34	Nut Flange Lock Top	119	532 43 81-66	Gearcase Subasm
18	532 18 76-90	Washer Spacer Mandrel	120	532 44 32-36	Keeper Belt RH
19	532 11 04-85	Bearing Ball Mandrel	121	532 43 69-85	Washer
20	532 17 39-84	Screw Thread Roll	124	532 43 69-86	Non Greasable Mandrel Shaft
23	817 49 06-28	Screw Thdrol 3/8 - 16 X 1-3/4	125	532 43 69-94	Bracket Idler Chasses
27	532 44 58-86	V-Belt Drive	127	532 19 34-06	Bolt Shoulder 3/8-16 x 3-5/8 Gr. 5
32	532 44 62-05	Spring Return Deck	128	532 17 48-73	Wheel Guage
33	532 18 72-81	Housing Mandrel 4pt Service	129	532 44 32-37	Rod Anti-Sway
34	532 19 28-72	Shaft Asm Mndrl N/Greasable38	130	819 13 13-12	Washer 13/32 x 13/16 x 12 Ga.
35	532 18 05-83	Blade Mower LH	131	532 19 42-08	Pin Cotter 5/16 Bow Tie Lock
36	532 19 30-03	Bolt/Washer Asm 7/16 - 20 unf	132	532 17 88-99	Knob Handle
42	817 00 05-12	Screw 5/16-18 x 3/4	133	532 43 81-97	EZ Mulch Door
43	532 44 32-39	Pulley Mandrel	134	532 43 58-61	Pin Hinge
45	532 13 71-52	Housing Mandrel	135	532 43 79-88	E-Ring 5/16
72	532 44 39-03	Chute Upper	136	532 43 96-39	Washout Port Remote Hookup
75	532 13 14-94	Pulley Idler Flat	137	812 00 00-29	Ring Klip
76	532 43 96-40	Washout Port	138	532 44 76-67	Hose Washout Port
84	532 44 32-35	Keeper Belt Mandrel	139	532 44 07-42	Hosw 3/8 Clamp
85	532 18 05-84	Blade Mower RH	140	580 36 99-01	Guard Asm. LH
86	532 18 17-13	Bolt 3/8-24 x 1.50 Gr. 8	141	532 44 77-03	Guard Asm. LH
87	810 03 06-00	Washer Lock Hvy 3/8	146	532 44 58-96	Spring Tex CRD EZ Mulch
88	532 14 02-96	Washer Hard Blade Mower Vented	156	532 44 69-95	Adapter Crossblade
91	819 13 20-12	Washer 13/32 x 1-1/4 x 12 Ga.	157	532 44 69-93	Blade Cross LH
94	532 19 72-50	Bracket Clutch Cable	158	532 18 04-25	Blade Cross RH
95	817 00 06-12	Screw 3/8-16 x 3/4	247	581 26 34-02	Guard Steel
96	532 40 02-71	Spacer	248	581 26 36-02	LH Rear Steel Guard
97	532 18 20-61	Shield Idler Mower	249	581 26 35-02	LH Front Steel Guard
98	532 19 51-61	Stud Fastener	--	532 19 28-70	Mandrel Assembly (Includes Housing, Shaft Assembly, And Bearing Only - Pulley/Nut/Washer And Blade Bolt/Washers Not Included)
99	532 19 51-86	Arm Suspension Mower Rear			Replacement Mower Complete
100	532 19 65-39	Bolt Shoulder			
101	873 68 09-00	Nut Crownlock 9/16 - 18 unc			
102	532 40 25-11	Spacer Bearing Swing Plate	--	532 44 73-19	
104	581 71 40-01	Mandrel Cover RH			
105	532 44 14-78	Mandrel Cover LH			
110	532 41 53-56	Gear Output			

NOTE: All component dimensions given in U.S. inches
1 inch = 25.4 mm

TRACTOR - MODEL NO. CTH224T (96051003600), PRODUCT NO. 96051 00-36
MOWER LIFT 45

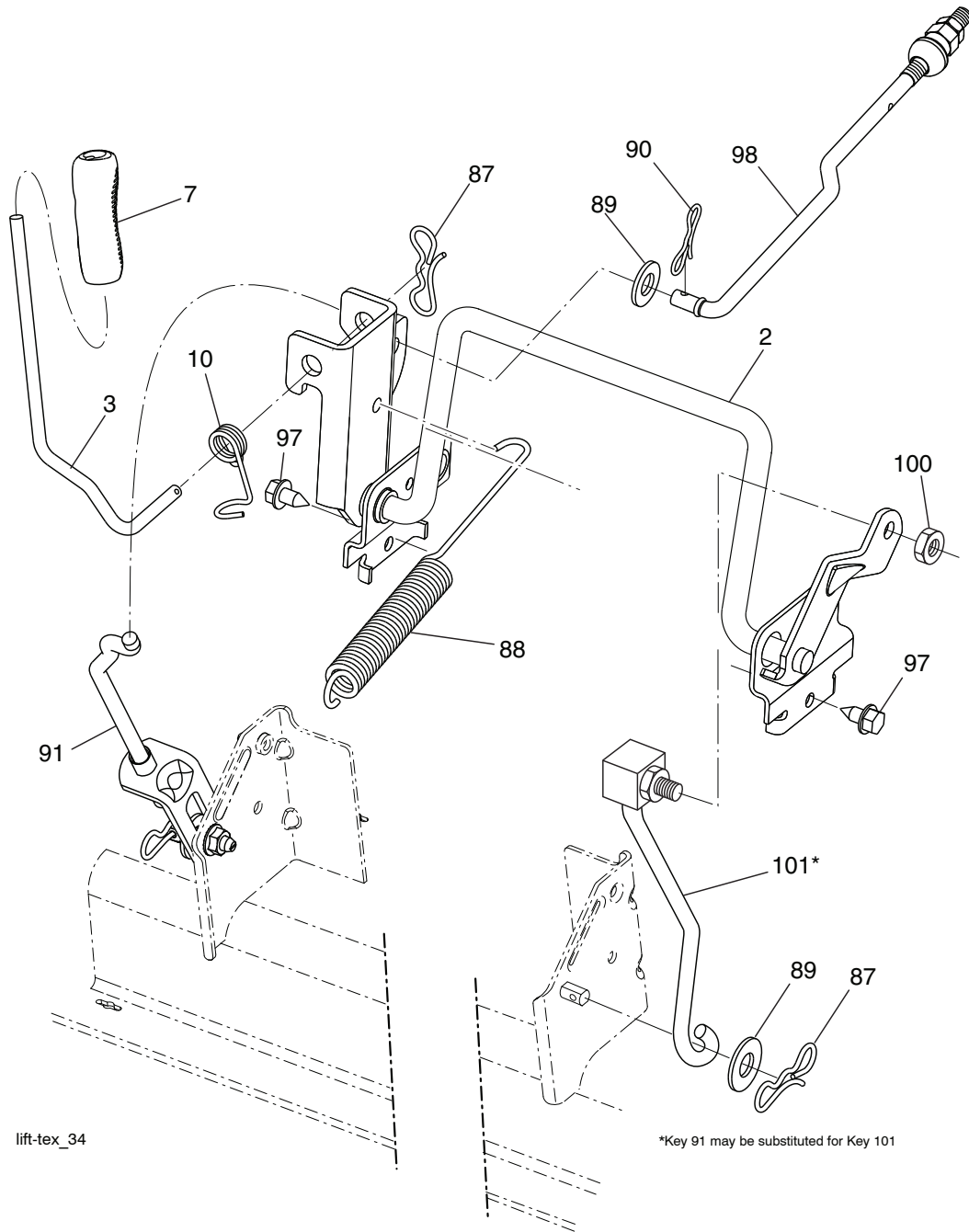

lift-tex_34

*Key 91 may be substituted for Key 101

KEY NO.	PART NO.	DESCRIPTION
2	532 43 69-96	Deck Lift Weldment
3	532 19 52-31	Lever Asm., Lift RH
7	532 41 15-55	Grip, Lever
10	532 19 63-14	Spring Torsion
87	532 19 42-09	Pin Cotter 7/16 Bow Tie Lock
88	532 44 54-96	Spring Lift Assist
89	819 19 19-12	Washer Clear Zinc
90	532 19 42-08	Pin Cotter 5/16 Bow Tie Lock
91	532 19 51-81	Link Lift Susp Mower Rear

KEY NO.	PART NO.	DESCRIPTION
97	817 49 06-08	Screw 3/8-16 x 1/2
98	532 19 52-70	Link Lift Susp. Front Mower
100	873 93 06-00	Nut Center Lock 3/8-16 unc
101	532 40 70-03	Link Asm Lift Fixed

NOTE: All component dimensions given in U.S. inches
 1 inch = 25.4 mm

TRACTOR - MODEL NO. CTH224T (96051003600), PRODUCT NO. 960 51 00-36
SEAT ASSEMBLY 42

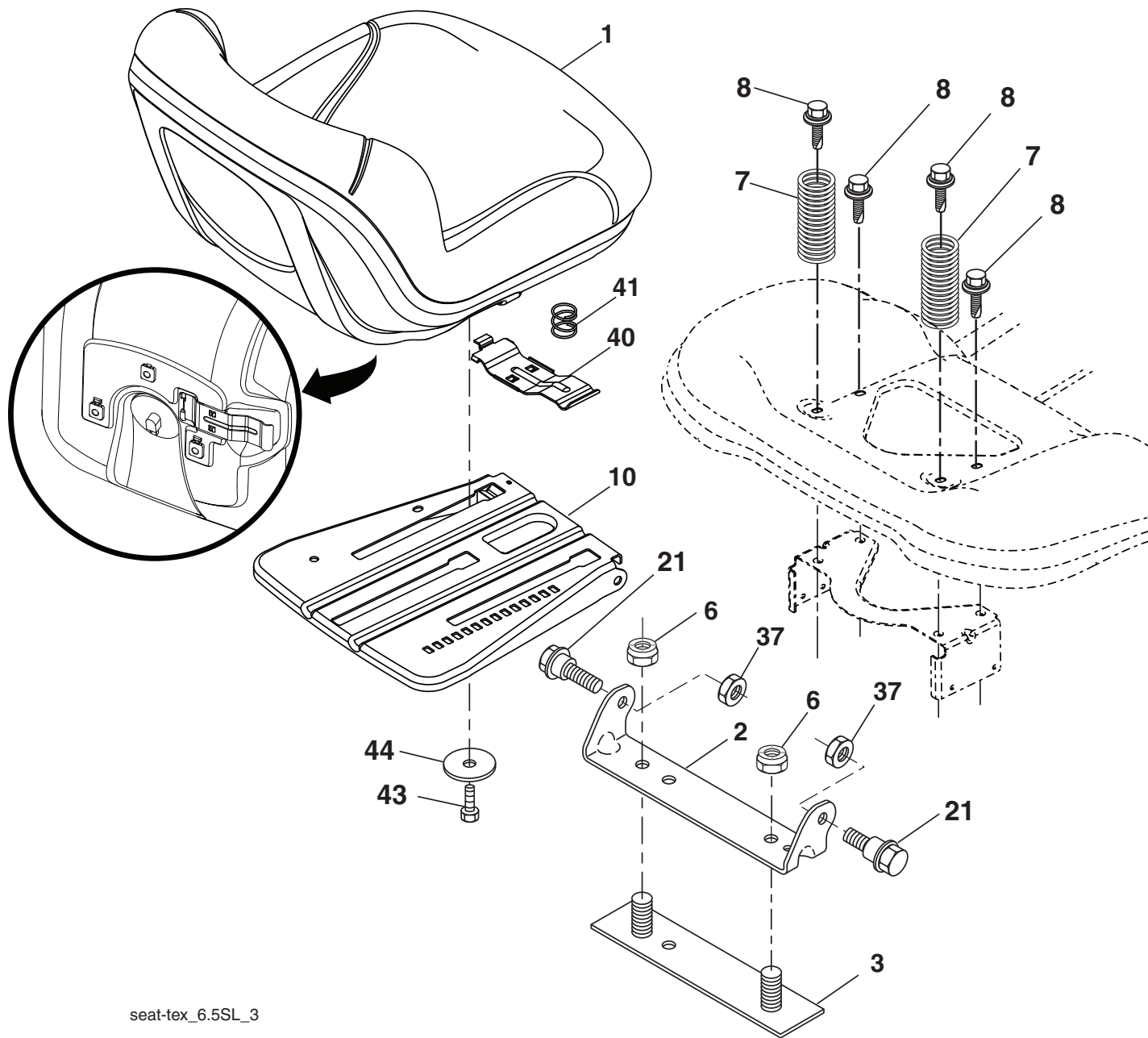

seat-tex_6.5SL_3

KEY NO.	PART NO.	DESCRIPTION
1	532 42 40-71	Seat
2	532 18 01-66	Bracket Pivot Fender
3	532 14 06-75	Strap, Asm Fender
6	873 80 06-00	Nut, Lock w/Ins. 3/8-16 unc
7	532 12 41-81	Spring, Seat Cprsn
8	532 17 18-77	Bolt 5/16-18 unc x 3/4 w/Sems
10	532 19 69-77	Pan, Seat
21	532 17 18-52	Bolt, Shoulder 5/16-18

KEY NO.	PART NO.	DESCRIPTION
37	873 80 05-00	Nut, Lock 5/16-18 unc
40	532 19 76-61	Handle Slide Seat
41	532 19 82-00	Spring Latch Seat
43	874 76 06-12	Bolt Fin Hex 3/8-16 unc x 3/4
44	819 13 38-12	Washer 13/32 x 2-3/8 x 12 Ga.

NOTE: All component dimensions given in U.S. inches
 1 inch = 25.4 mm

TRACTOR - MODEL NO. CTH224T (96051003600), PRODUCT NO. 96051 00-36
BAGGER **46**

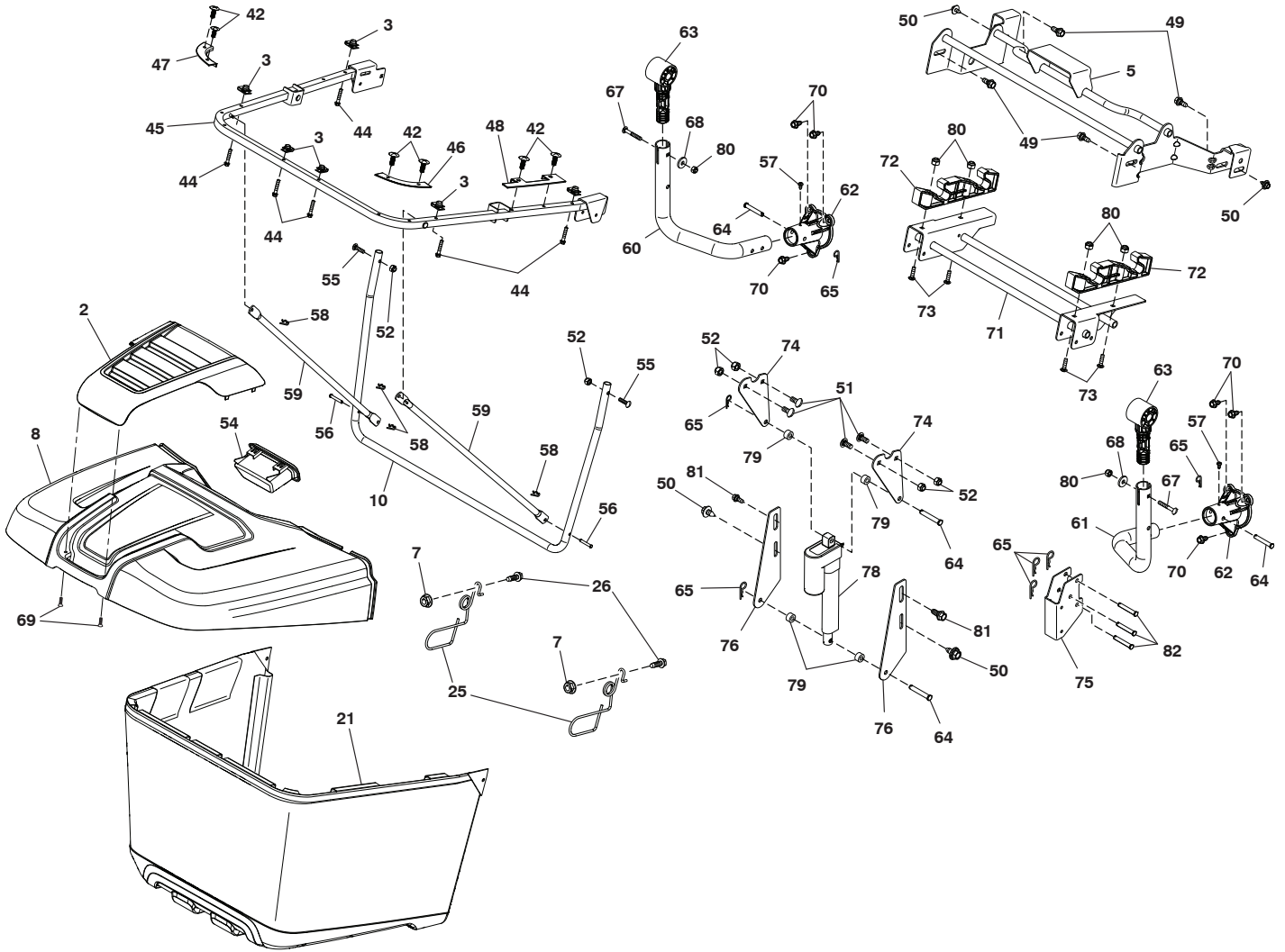

ElecBagger_TexCRD-Gen2_1

**TRACTOR - MODEL NO. CTH 224T (96051003600), PRODUCT NO. 960 51 00-36
BAGGER 46**

KEY NO.	PART NO.	DESCRIPTION
2	532 44 75-72	Applique
3	532 17 48-14	Clip
5	532 44 52-48	Bagger Cross Tube
7	873 90 04-00	Nut Hex Flange 1/4-20 unc
8	580 40 32-01	Bagger Top
10	532 44 37-55	Frame Front
21	532 44 59-43	Bag Assembly
25	532 44 55-28	Spring Latch Bagger
26	817 49 04-12	Screw Hex Thdrol 1/4-20 x 3/4
42	532 44 04-28	Clip
44	532 19 96-87	Bolt 1/4-20
45	532 44 37-54	Upper Frame
46	532 44 55-41	Bag Corner Close Out RH
47	532 44 40-79	Bag Corner Close Out LH
48	532 44 40-80	Top Bagger Side Close Out
49	532 17 18-73	Bolt Shoulder 5/16-18
50	532 17 18-77	Bolt 5/16-18 x 3/4 W/Sems
51	872 11 05-06	Bolt 5/16 x 18 x 3/4
52	873 80 05-00	Nut Lock Hex W/Ins 5/16-18 unc
54	532 44 72-18	Bagger Top Front Handle
55	872 14 05-12	Bolt 5/16-18 x 1-1/2
56	532 42 03-06	Pin Clevis .183 x 1.26
57	532 19 98-55	Screw 1/4-20 Panhead
58	532 08 51-79	Clip Retainer
59	532 44 47-63	Bagger Sprd Tube
60	532 44 41-05	Bagger Support Tube LH
61	532 44 41-06	Bagger Support Tube RH
62	532 44 45-42	Bracket Support
63	532 44 41-11	Bagger Pivot Elec Dump
64	532 43 04-22	Pin Clevis .375 x 2.375
65	532 12 47-88	Retainer Spring 1"
67	872 11 05-18	Bolt Carriage
68	819 11 16-10	Washer 11/32 x 1.00 x 10 Ga.
69	532 42 18-01	Screw #8 Flat Head Drill
70	817 00 06-12	Screw 3/8-16 x 3/4
71	532 44 52-38	Bagger Support Pivot
72	532 44 52-36	Bagger Catch Bracket
73	872 11 05-10	Bolt Carriage 5/16-18 X 1-1/4 Gr. 5
74	532 44 52-43	Upper Clevis Bracket
75	532 44 52-45	Lower Mounting Bracket
76	532 44 52-44	Lower Clevis Bracket
78	532 44 52-57	Actuator Elec Dump
79	532 44 73-68	Spacer .375 x .75 x .4375
80	873 90 05-00	Nut Lock Hex Flange 5/16-18
81	532 17 01-65	Bolt Shoulder 5/16-18
82	877 10 12-36	Clevis Pin 0.375 x 2.000

NOTE: All component dimensions given in U.S. inches
1 inch = 25.4 mm

