

**532 44 69-19**



# **Repair Parts Manual IPL Manual**

**GTH26V54 / 96048003500**

Please read the operator's manual carefully and make sure you understand the instructions before using the machine.

Lisez très attentivement et soyez certain de comprendre ces instructions avant d'utiliser cette machine.



**English**

# HOW TO USE THIS MANUAL

This manual is designed to provide the customer with a means to identify the parts on his/her tractor when ordering repair parts. The illustrations may or may not represent the actual assemblies; therefore, it is not recommended to use this manual as a guide to assemble or disassemble the tractor. Some hardware and parts are drawn larger in order to more readily identify them.

Each tractor has its own model number.

The model number for your tractor can be found on the fender under the seat.

When ordering parts, always give the following information:

- Product - "TRACTOR"
- MODEL NUMBER - "GTH26V54" (96048003500)"
- Part Number
- Part Description

## TABLE OF CONTENTS

SCHEMATIC .....	3
ELECTRICAL.....	4-5
CHASSIS .....	6-7
DRIVE.....	8-9
ENGINE.....	10-11
STEERING .....	12-13
MOWER DECK.....	14-15
MOWER LIFT.....	16
SEAT .....	17
DECALS.....	18

## COMMENT UTILISER CE MANUEL

Ce manuel a été dessiné pour fournir le client avec les moyens d'identification des pièces de détachées du tracteur quand il/elle a besoin de commander les pièces de rechange. Les illustrations ne peuvent pas représenter exactement le modèle que vous avez acheté. N'utilisez pas ce manuel comme un guide dans le montage et/ou démontage de votre tracteur. La visserie montrée est plus grande pour faciliter l'identification.

Chaque tracteur a un numéro de modèle particulier.

Le numéro de modèle du produit se trouvera sur l'aile, dessous le siège.

Lorsque vous commandez des pièces de rechange, donnez toujours les renseignements suivants:

- Produit - "TRACTEUR"
- NUMÉRO DU MODÈLE - "GTH26V54 (96048003500)"
- Numéro de la Pièce
- Description de la Pièce

## TABLE DE MATIERES

SCHÉMA .....	19
ELECTRIQUE .....	20-21
CHÂSSIS/ENCEINTES.....	22-23
ENTRAÎNEMENT .....	24-25
MOTEUR.....	26-27
ENSEMBLE DE LA DIRECTION.....	28-29
CARTER DE TONDEUSE.....	30-31
LEVAGE DE LA TONDEUSE.....	32
ENSEMBLE DU SIÈGE .....	33
DECALCOMANIES.....	34

# TRACTOR - MODEL NO. GTH26V54 (96048003500), PRODUCT NO. 960 48 00-35 SCHEMATIC

SCH12

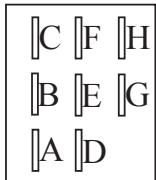
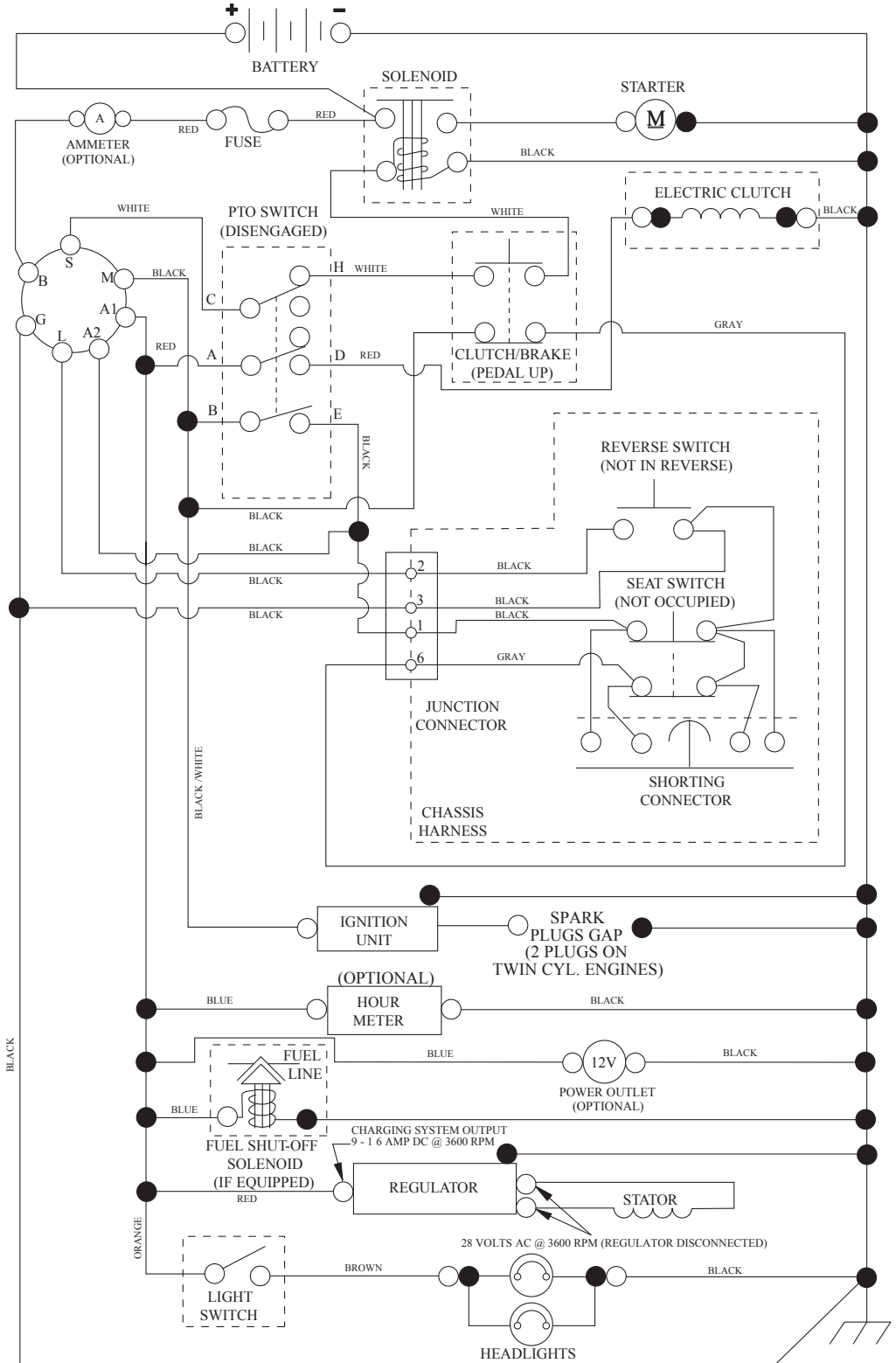

PTO SWITCH  
(MATING SIDE)

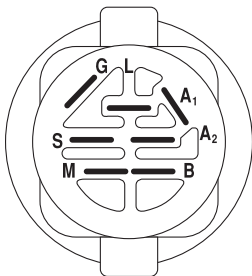

IGNITION SWITCH

POSITION	CIRCUIT	"MAKE"
OFF	M+G+A1	
RUN/OVERRIDE	B+A1	
RUN	B+A1	L+A2
START	B + S + A1	

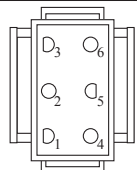

CHASSIS HARNESS  
CONNECTOR  
(MATING SIDE)

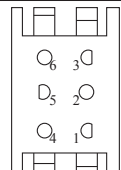

DASH HARNESS  
CONNECTOR

WIRING INSULATED CLIPS  
NOTE: IF WIRING INSULATED  
CLIPS WERE REMOVED FOR  
SERVICING OF UNIT, THEY  
SHOULD BE RE-INSTALLED TO  
PROPERLY SECURE YOUR  
WIRING.

●  
NON-REMOVABLE  
CONNECTIONS

○  
REMOVABLE  
CONNECTIONS

**TRACTOR - MODEL NO. GTH26V54 (96048003500), PRODUCT NO. 960 48 00-35  
ELECTRICAL**

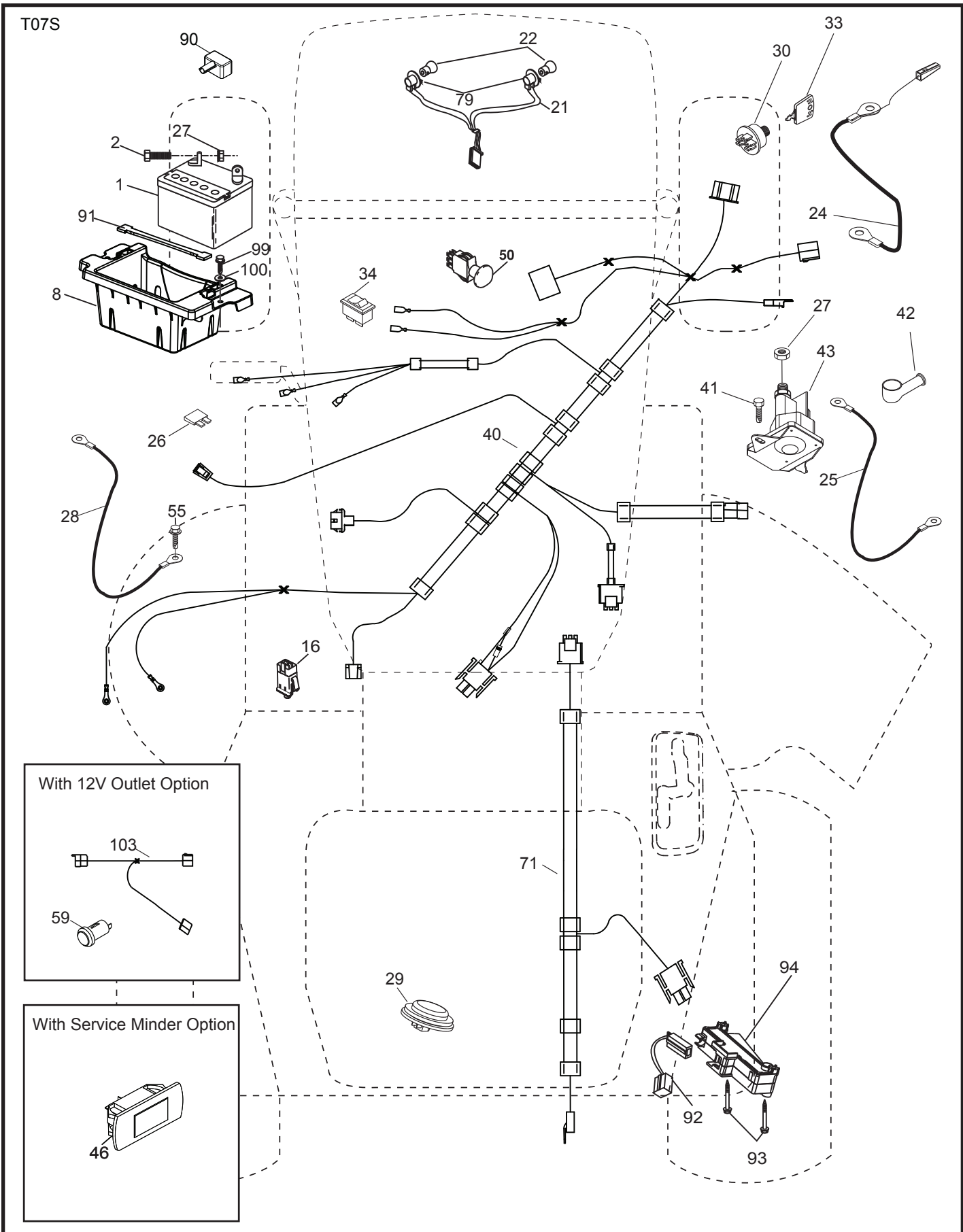

**TRACTOR - MODEL NO. GTH26V54 (96048003500), PRODUCT NO. 960 48 00-35  
ELECTRICAL**

<b>KEY NO.</b>	<b>PART NO.</b>	<b>DESCRIPTION</b>
1	532 16 34-65	Battery
2	874 76 04-12	Bolt Hex Hd 1/4-20 unc x 3/4
8	532 18 64-91	Battery Box
16	532 17 61-38	Switch Interlock
21	532 40 02-52	Harness Socket Light w/4152J
22	532 00 41-52	Bulb, Light # 1156
24	532 40 02-53	Cable Battery
25	532 41 28-95	Cable Starter
26	532 17 51-58	Fuse
27	873 51 04-00	Nut Keps Hex 1/4-20 unc
28	532 14 54-91	Cable Ground
29	532 40 15-45	Switch Seat
30	532 19 33-50	Switch Ign
33	532 41 19-35	Key/Chain
34	532 11 07-12	Switch Light/Reset
40	532 40 11-04	Harness Ign. Dash/Lift
41	817 72 04-08	Screw Thd Cut 1/4-20 x 1/2
42	532 13 15-63	Cover Terminal Red
43	532 19 25-07	Solenoid
46	532 40 17-63	Gauge Hourmeter
50	532 17 46-51	Switch PTO
55	817 06 05-12	Screw Thdrol 5/16-18 x 3/4
59	532 40 03-03	Outlet 12-Volt
71	532 19 42-76	Harness Ign Chassis/Lift
79	532 17 52-42	Socket Asm Bulb Twistlock
90	532 43 53-95	Cover Terminal Battery
91	532 19 02-70	Strap Battery
92	532 19 66-15	Harness Pigtail Console ROS
93	532 19 25-40	Screw Plastite 10-14 x 2.0
94	532 19 18-34	Module Reverse ROS
99	817 67 04-12	Screw Hexwsh Thdrol 1/4-20 x 3/4
100	819 09 14-16	Washer 9/32 x 7/8 x 16 Ga.
103	532 40 79-62	Harness Pigtail 12V Outlet

**NOTE:** All component dimensions given in U.S. inches.  
1 inch = 25.4 mm

**TRACTOR - MODEL NO. GTH26V54 (96048003500), PRODUCT NO. 960 48 00-35  
CHASSIS**

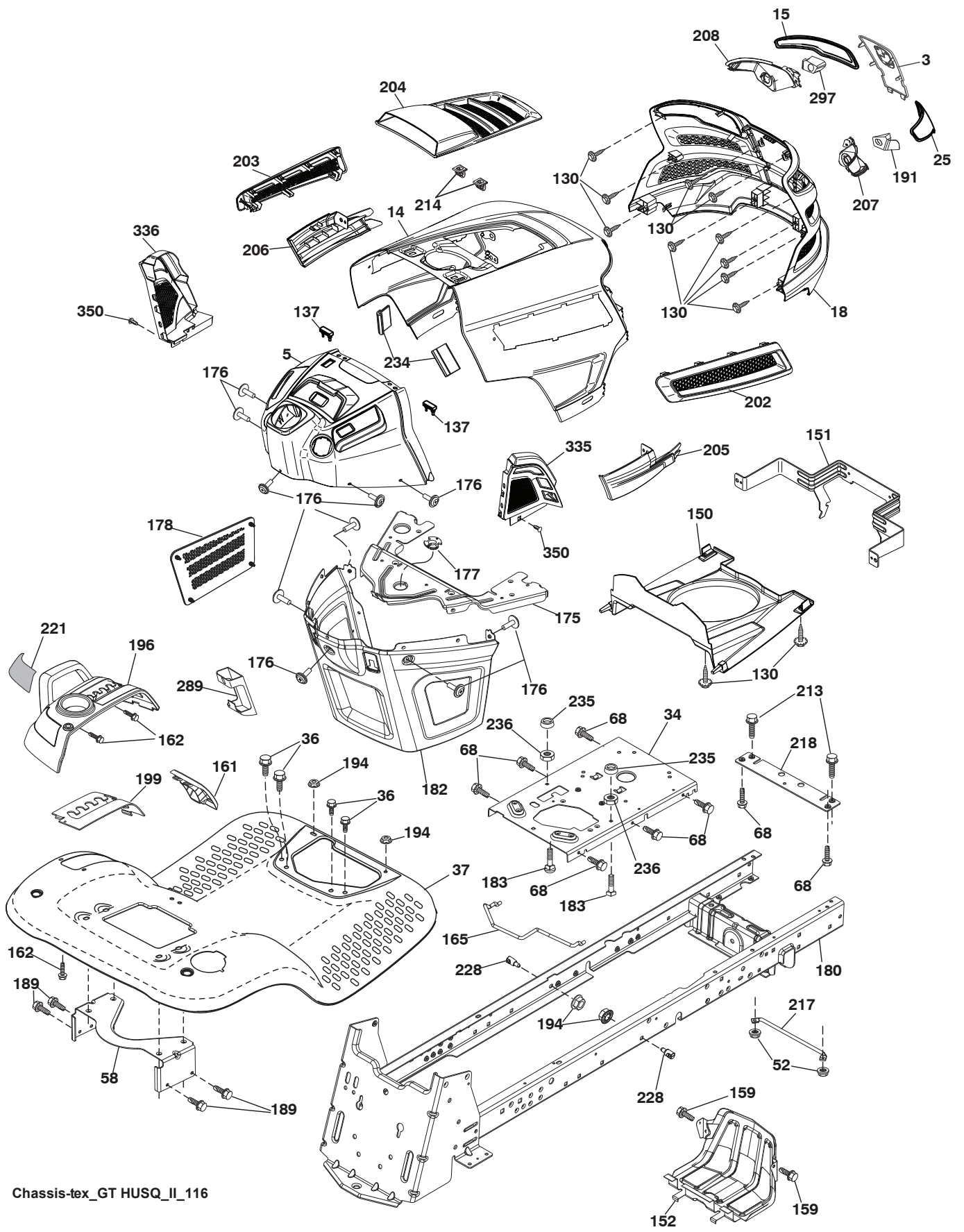

Chassis-tex\_GT HUSQ\_IL\_116

**TRACTOR - MODEL NO. GTH26V54 (96048003500), PRODUCT NO. 960 48 00-35  
CHASSIS**

<b>KEY NO.</b>	<b>PART NO.</b>	<b>DESCRIPTION</b>	<b>KEY NO.</b>	<b>PART NO.</b>	<b>DESCRIPTION</b>
3	532 43 97-52	Applique	191	532 43 74-55	Insert Reflective RH
5	532 43 74-71	Dash	194	873 90 05-00	Nut Lock 5/16-18
14	532 44 11-77	Hood	196	532 43 97-16	Console Asm. Deck Lift
15	532 43 97-33	Lens LH	199	532 19 82-59	Plate Deck Lift
18	532 43 77-62	Grille	202	532 43 97-28	Vent Side Hood RH
25	532 44 33-85	Lens RH	203	532 43 97-27	Vent Side Hood LH
34	532 44 72-53	Plate Engine	204	532 43 57-14	Vent Asm Hood Top
36	817 06 05-12	Screw 5/16-18 x 3/4	205	532 43 97-30	Skirt Hood Side RH
37	532 44 12-08	Fender	206	532 43 97-29	Skirt Hood Side LH
52	873 68-05-00	Nut Crown Lock 5/16-18	207	532 43 97-34	Bezel RH
58	532 19 43-14	Bracket Fender	208	532 43 97-35	Bezel LH
68	817 49 05-08	Screw 5/16-18 x 1/2	213	874 76 05-12	Bolt Hex Hd 5/16-18 unc x 3/4
130	532 41 63-58	Screw #10 x 0.750 BOS Thread	214	532 19 91-45	Clip Retainer
137	532 40 75-90	Bumper Dash	217	532 40 91-67	Rod Pivot
150	532 43 97-74	Duct Heat Hood	218	532 19 63-95	Hood Stop X Piece
151	532 43 66-70	Bracket, Pivot	221	532 19 89-09	Reflector LH
152	532 43 60-86	Shield Browning	228	532 19 51-61	Stud Fastener
159	817 00 05-12	Screw 5/16-18 x 3/4	234	532 40 47-42	Bumper Hood
161	532 43 99-29	Console Fuel Window	235	532 40 61-29	Spacer Fender
162	532 14 24-32	Screw Hex Wsh Hi-Lo 1/4 x 1/2	236	873 93 05-00	Nut Center Lock 5/16-18 unc
165	532 19 68-26	Bracket Support Tank	289	532 40 35-71	Plug Cruise/Phone
175	532 19 63-04	Crossmember	297	532 43 74-56	Insert Reflective LH
176	532 40 07-76	Screw 10-24 x 5/8 Wshd Qdrx	335	532 44 82-04	Cover Lower Dash RH
177	532 19 52-27	Bushing Steering	336	532 44 53-09	Cover Lower Dash LH
178	532 19 97-82	Cargo Asm. Net	350	532 44 51-43	Clip
180	532 19 54-77	Chassis	- - -	532 40 09-44	Kit Bumper
182	532 40 68-59	Dash Lower			
183	874 52 05-20	Bolt 5/16-18 x 1-1/4			
189	817 00 06-12	Screw 5/16-18 x 3/4			

**NOTE:** All component dimensions given in U.S. inches.  
1 inch = 25.4 mm

**TRACTOR - MODEL NO. GTH26V54 (96048003500), PRODUCT NO. 960 48 00-35 DRIVE**

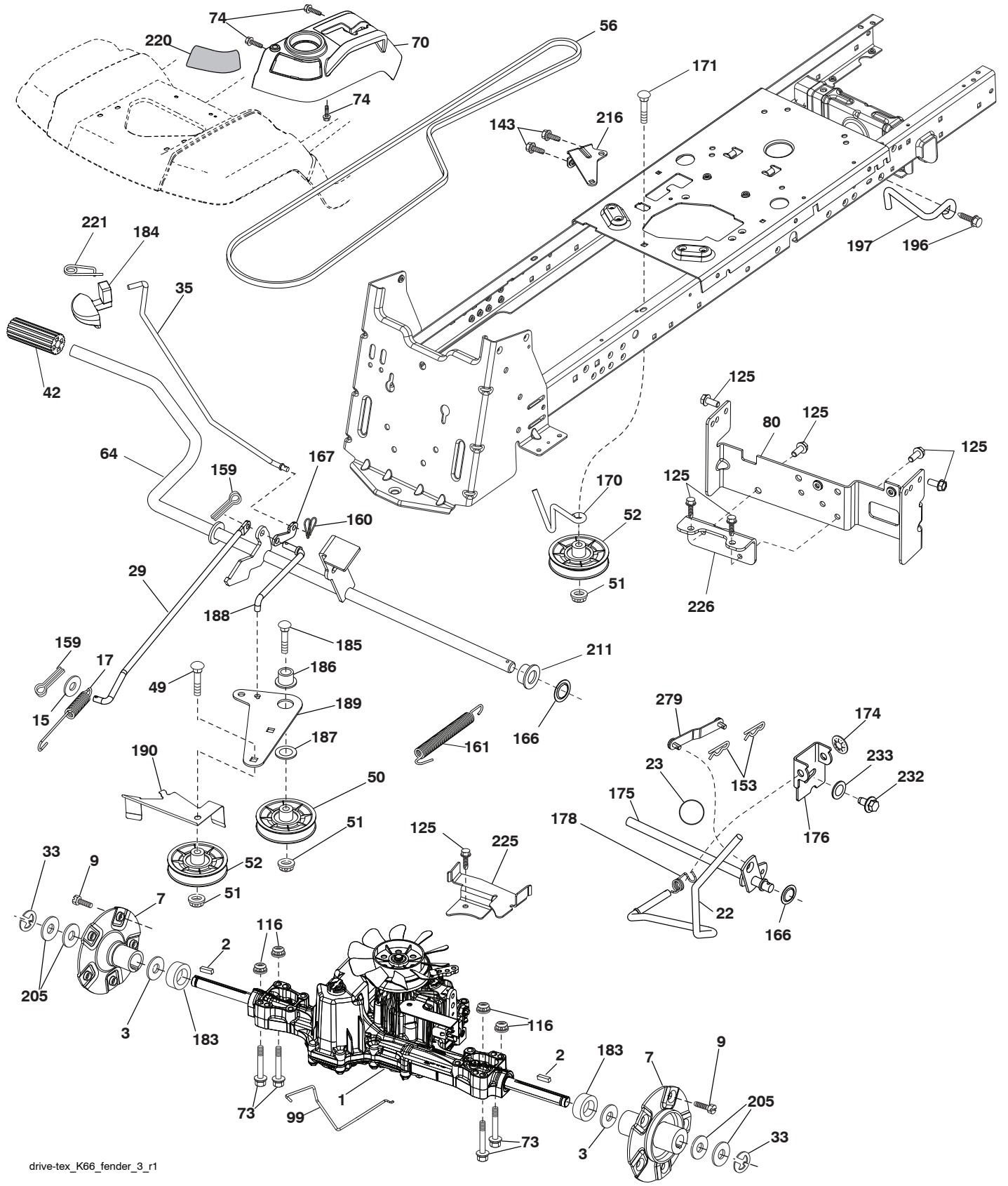

drive-tex\_K66\_fender\_3\_r1



# TRACTOR - MODEL NO. GTH26V54 (96048003500), PRODUCT NO. 960 48 00-35 DRIVE

KEY NO.	PART NO.	DESCRIPTION	KEY NO.	PART NO.	DESCRIPTION
1	---	Transaxle, TUFFTORQ K66AD (414145) (Order parts from trans-axle manufacturer.)	167	532 40 52-57	Latch Brake Parking
2	532 00 70-70	Key	170	532 19 43-22	Keeper Belt Centerspan
3	532 00 75-63	Washer Thrust Axle Hardened	171	872 11 06-16	Bolt 3/8-16 unc
7	532 19 98-37	Hub Asm. Wheel Rear	174	532 19 72-89	Nut Push
9	532 14 00-80	Bolt Hub Wheel Rear	175	532 40 85-39	Shaft Asm Shift
15	819 13 13-16	Washer 13/32 x 13/16 x 16 Ga.	176	532 19 62-14	Arm Clevis Rod Shift
17	532 40 10-72	Spring Brake	178	532 19 74-56	Spring Shift
22	532 19 73-29	Rod Shift	183	532 19 73-57	Spacer Split
23	532 14 08-45	Knob	184	532 44 14-55	Handle Parking Brake
29	532 40 72-45	Rod, Brake	185	872 11 06-22	Bolt Rdhd Sqnk 3/8-16 x 2-3/4 Gr. 5
33	812 00 00-53	Ring E	186	532 19 43-21	Spacer Retainer
35	532 43 54-86	Rod Brake Park	187	819 13 32-10	Washer
42	532 12 48-72	Cover Foot Pedal	188	532 19 43-23	Link Clutch Ground Drive
49	872 11 06-14	Bolt	189	532 19 43-17	Bellcrank Ground Drive
50	532 19 43-27	Pulley Idler Flat	190	532 19 43-18	Keeper Bellcrank Ground Drive
51	873 90 06-00	Lock Nut 3/8-16	196	817 00 06-16	Screw 3/8-16 x 1
52	532 19 43-26	Idler V-Groove	197	532 19 97-69	Link Clutch Anti-Rotation
56	532 12 59-07	V-Belt Drive	205	532 12 38-00	Washer 1-1/32 x 1-5/8 x 16 Ga.
64	532 19 62-00	Shaft Asm. Pedal Brake Control	211	532 19 62-12	Bushing Brake Shaft
70	532 43 96-60	Console Asm.	216	532 19 61-31	Bracket Pulley Idler
73	874 49 05-44	Bolt Hex 5/16-18 x Gr. 5	220	532 19 89-08	Reflector RH
74	532 14 24-32	Screw 1/4 x 1/2	221	532 40 31-87	Retainer Spring Clip Handle
80	532 40 71-82	Strap Torque	225	532 40 73-11	Keeper Belt Trans.
99	532 41 57-44	Rod Bypass	226	532 40 71-09	Bracket Mount Torque
116	873 90 05-00	Nut Lock Hex Flange 5/16-18	232	874 78 07-16	Bolt 7/16-14 x 1 Gr. 5
125	817 00 05-12	Screw 5/16-18 x 3/4	233	532 40 52-96	Washer Serrated
143	817 49 05-08	Screw 5/16-18 x 1/2	279	532 41 37-78	Link Shift
153	532 12 47-88	Retainer Spring			
159	876 02 04-12	Pin Cotter 1/8 x 3/4			
160	532 16 94-84	Retainer Clip			
161	532 10 57-09	Spring Return Clutch			
166	532 42 91-64	Nut Push			

**NOTE:** All component dimensions given in U.S. inches.  
1 inch = 25.4 mm

**TRACTOR - MODEL NO. GTH26V54 (96048003500), PRODUCT NO. 960 48 00-35  
ENGINE**

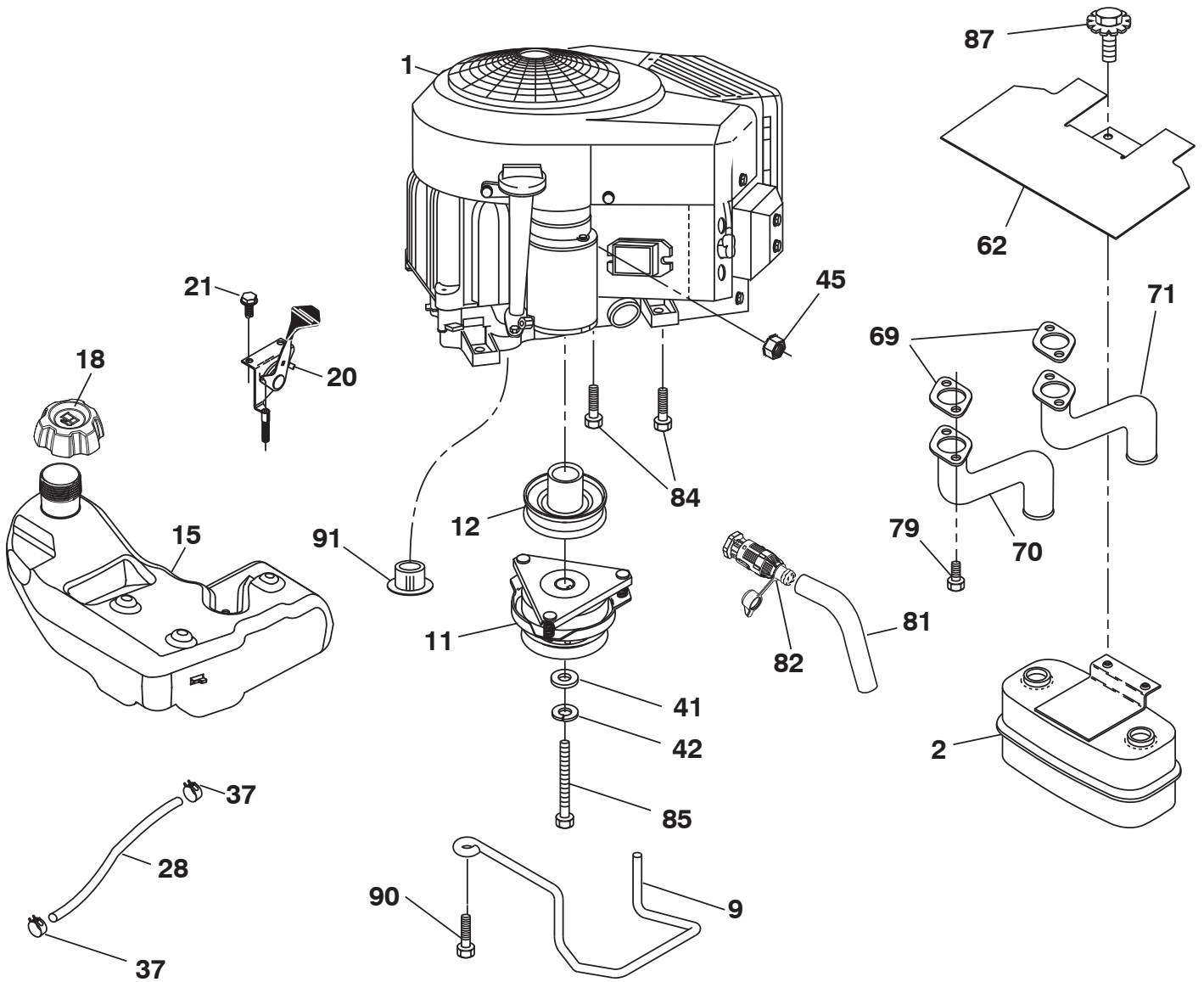

**SPARK ARRESTER KIT**

engine-tex\_bs-2cyl\_85

# TRACTOR - MODEL NO. GTH26V54 (96048003500), PRODUCT NO. 960 48 00-35 ENGINE

KEY NO.	PART NO.	DESCRIPTION
1	---	Engine B & S Model No. 44P777-0185-G5 (580326001) (Order parts from engine manufacturer.)
2	532 44 59-62	Muffler
9	532 19 43-20	Keeper Belt Engine
11	532 17 93-35	Clutch Electric
12	532 19 43-43	Pulley Engine
15	532 19 34-99	Tank Fuel 4.0
18	532 43 96-45	Cap Fuel
20	532 42 35-02	Control Throttle
21	532 41 63-58	Screw #10 x 0.750 BOS Thread
28	532 14 21-58	Fuel Line
29	532 13 71-80	Spark Arrester Kit
37	532 12 34-87	Clamp Hose
41	532 12 61-97	Washer 1-1/2 OD x 15/32 ID x .250
42	810 04 07-00	Washer Lock 7/16
45	873 51 04-00	Nut Keps Hex 1/4-20 unc
62	532 43 40-17	Shield Heat Muffler
69	532 16 53-91	Gasket
70	532 15 99-55	Tube Exhaust LH
71	532 16 05-89	Tube Exhaust RH
79	532 18 39-06	Screw Socket Head 5/16-18 x 1
81	532 14 84-56	Tube Drain Oil Easy
82	532 42 82-87	Plug Drain Oil
84	817 06 06-20	Screw 3/8-16 x 1/4
85	532 17 99-53	Bolt Hex 7/16-20 x 3.75 Gr. 5
87	532 17 18-77	Bolt 5/16-18 x 3/4
90	817 00 06-16	Screw 3/8-16 x 1
91	532 18 74-95	Bushing

**NOTE:** All component dimensions given in U.S. inches.  
1 inch = 25.4 mm

For engine service and replacement parts, call the toll free number for your engine manufacturer listed below:

Briggs & Stratton      1-800-233-3723

## Engine Power Rating Information

The gross power rating for individual gas engine models is labeled in accordance with SAE (Society of Automotive Engineers) code J1940 (Small Engine Power & Torque Rating Procedure), and rating performance has been obtained and corrected in accordance with SAE J1995 (Revision 2002-05). Torque values are derived at 3060 RPM; horsepower values are derived at 3600 RPM. Actual gross engine power will be lower and is affected by, among other things, ambient operating conditions and engine-to-engine variability. Given both the wide array of products on which engines are placed and the variety of environmental issues applicable to operating the equipment, the gas engine will not develop the rated gross power when used in a given piece of power equipment (actual "on-site" or net power). This difference is due to a variety of factors including, but not limited to, accessories (air cleaner, exhaust, charging, cooling, carburetor, fuel pump, etc.), application limitations, ambient operating conditions (temperature, humidity, altitude), and engine-to-engine variability. Due to manufacturing and capacity limitations, Briggs & Stratton may substitute an engine of higher rated power for this Series engine.

**TRACTOR - MODEL NO. GTH26V54 (96048003500), PRODUCT NO. 960 48 00-35**  
**STEERING ASSEMBLY**

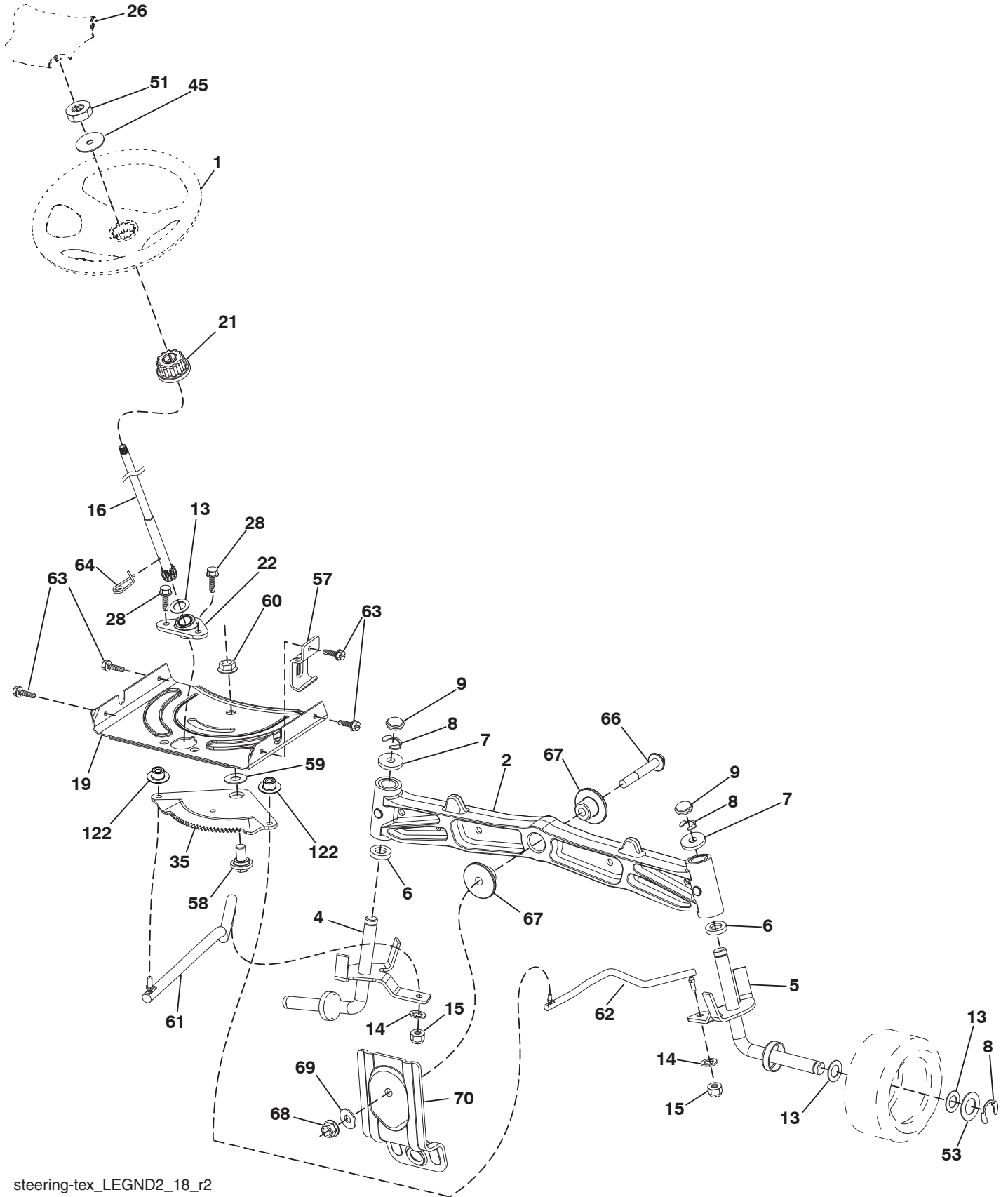

steering-tex\_LEGND2\_18\_r2

**TRACTOR - MODEL NO. GTH26V54 (96048003500), PRODUCT NO. 960 48 00-35  
STEERING ASSEMBLY**

<b>KEY NO.</b>	<b>PART NO.</b>	<b>DESCRIPTION</b>
1	532 43 97-40	Wheel, Steering
2	532 19 59-68	Axle Asm., Front
4	532 40 30-89	Spindle Asm., LH
5	532 40 30-90	Spindle Asm., RH
6	532 12 49-31	Bearing, Race Thrust Harden
7	532 12 17-48	Washer 25/32 x 1-5/8 x 16 Ga.
8	812 00 00-29	Ring, Klip #T5304-75
9	532 12 12-32	Cap, Spindle
13	532 12 17-49	Washer 25/32 x 1-1/4 x 16 Ga.
14	810 04 06-00	Washer, Lock Hvy Hlcl Spr 3/8
15	873 54 06-00	Nut, Crown Lock 3/8-24 unf
16	532 40 82-19	Shaft Steering
19	532 19 47-29	Plate Steering
21	532 18 67-37	Adapter, Wheel Steering
22	532 42 05-37	Steering Support Lower
26	532 43 97-43	Insert, Wheel Steering
28	817 00 06-12	Screw 3/8-16 x 3/4
35	532 19 47-32	Gear, Sector Plate
45	819 18 38-12	Washer 9/16 x 2-3/8 x 12 Ga.
51	873 94 08-00	Nut Hex Jam Toplock 1/2-20 unf
53	532 18 89-67	Washer Hardened .793 x 1.637 x .060
57	532 19 72-46	Bracket Upstop
58	532 19 47-47	Bolt Shoulder Sector Pivot CFM
59	532 19 47-48	Washer Thrust Sector Steering
60	873 97 10-00	Nut Flange Lock 5/8-11
61	532 19 47-40	Draglink, LH
62	532 19 47-41	Draglink, RH
63	817 00 05-12	Screw 5/16-18 x 3/4
64	532 19 98-49	Retainer Clip Spring Steering
66	871 02 07-48	Bolt Hex Fghd 7/16-14 x 3 Serr
67	532 19 47-37	Bushing PM Front Axle
68	873 90 07-00	Nut Lock Flange 7/16-14 Gr. 5
69	532 19 91-62	Washer 1.5 x .505 x .118
70	532 19 61-97	Bracket Deck Susp. Front
122	532 44 49-62	Cap Gear Sector

**NOTE:** All component dimensions given in U.S. inches.  
1 inch = 25.4 mm

**TRACTOR - MODEL NO. GTH26V54 (96048003500), PRODUCT NO. 960 48 00-35  
MOWER DECK**

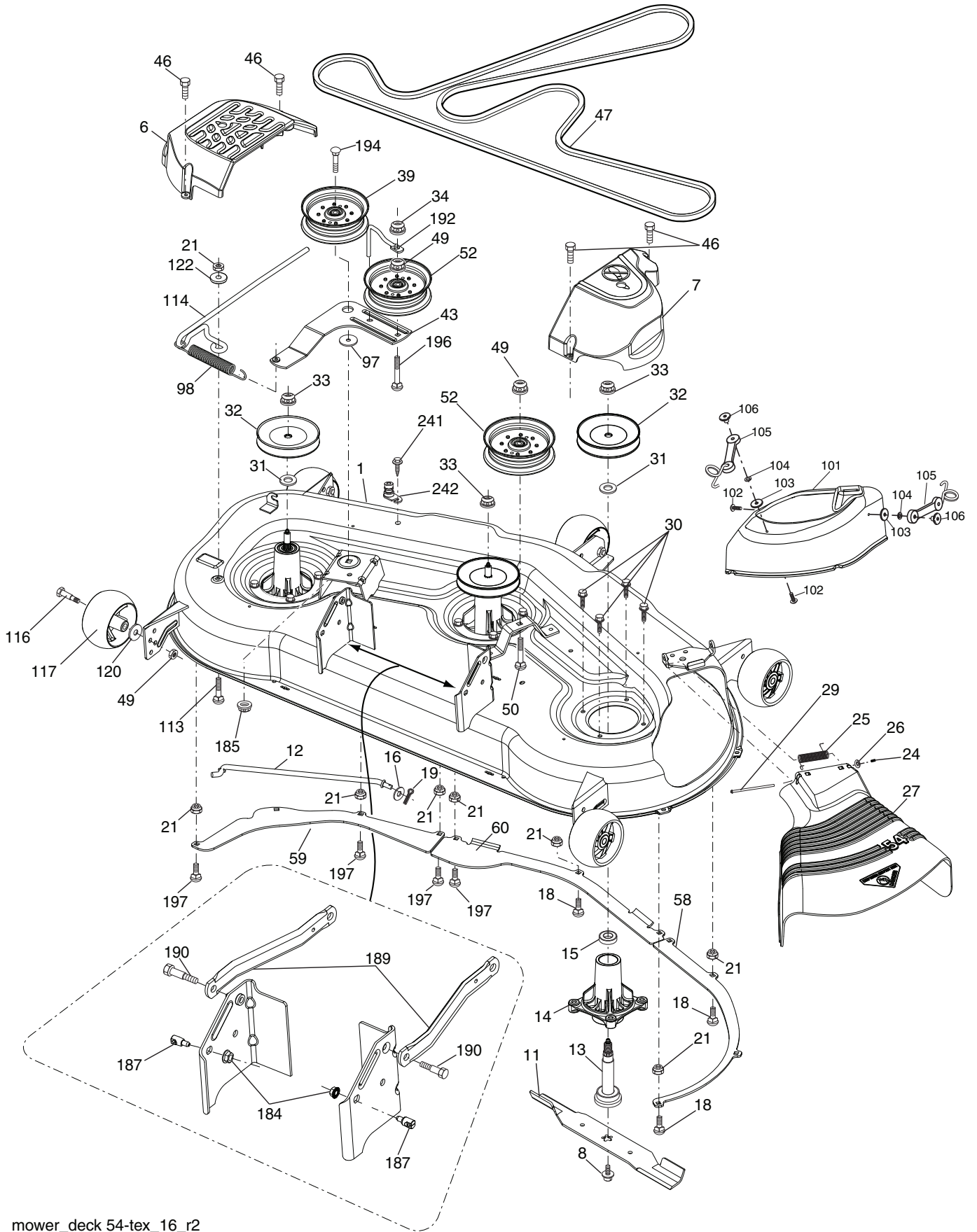

mower\_deck 54-tex\_16\_r2

**TRACTOR - MODEL NO. GTH26V54 (96048003500), PRODUCT NO. 960 48 00-35  
MOWER DECK**

<b>KEY NO.</b>	<b>PART NO.</b>	<b>DESCRIPTION</b>	<b>KEY NO.</b>	<b>PART NO.</b>	<b>DESCRIPTION</b>
1	532 44 50-61	Deck Weldment Mower	98	532 19 61-05	Spring Drive
6	532 19 60-66	Cover Mandrel LH	101	532 18 72-98	Cover Mulch
7	532 19 71-81	Cover Mandrel RH	102	871 08 10-10	Screw 10-24 x 5/8
8	532 19 30-03	Bolt 7/16 Asm. Blade	103	819 06 12-16	Washer #10
11	532 18 72-56	Blade Bagging	104	810 07 10-00	Washer #10
-	532 18 72-55	Blade Mulching	105	532 16 07-93	Latch Asm.
12	532 40 03-37	Rod Anti-Sway	106	532 12 50-04	Nut Weld .327/.304 #10-24
13	532 18 72-91	Shaft Asm. w/Lower Bearing	113	872 11 05-08	Bolt Rdhd Sqnk 5/16-18 x 3/4
14	532 18 72-81	Housing, Mandrel	114	532 18 75-56	Rod Tension Relief
16	819 13 13-12	Washer 3/8	116	532 19 34-06	Bolt, Shoulder
15	532 11 04-85	Bearing, Ball, Mandrel	117	532 17 48-73	Gauge Wheel
18	872 14 05-05	Bolt Carriage 5/16-18 x 5/8	120	819 13 20-12	Washer 13/32 x 1-1/4 x 12 Ga.
19	532 19 42-08	Pin Cotter 5/16 Bowtie	122	532 18 75-57	Bushing Tension Relief
21	873 68 05-00	Nut, Crownlock 5/16-18 unc	184	873 90 05-00	Nut Lock Hex Flange
24	532 10 53-04	Cap Sleeve	185	873 90 07-00	Nut Lock Flange 7/16-14 Gr. 5
25	532 17 81-02	Spring, Torsion	187	532 19 51-61	Stud Fastener w/"D" Anti-Rotation
26	532 11 04-52	Nut, Push	189	532 19 51-85	Arm Susp. Mower Rear
27	532 18 89-38	Deflector Shield	190	532 19 65-39	Bolt Shoulder
29	532 13 14-91	Rod, Hinge	192	532 19 84-68	Keeper Belt Idler
30	532 17 39-84	Screw, Thdroll Washer Head	194	874 49 07-36	Bolt Carr Sqnk 7/16-24 x 2
31	532 18 76-90	Washer, Spacer Mower Vented	196	872 14 06-20	Bolt Rdhd 3/8-16 x 2-1/2 Gr. 5
32	532 15 35-35	Pulley, Mandrel	197	872 14 05-08	Bolt 5/16-18 unc x 1
33	532 40 02-34	Nut, Flg. Top Lock	241	532 15 29-27	Screw #10-32.5 3/8 Flange
34	873 68 06-00	Nut Crownlock 3/8-16 unc	242	532 41 55-98	Port Washout
39	532 19 73-80	Pulley, Idler, 4.50	--	532 41 64-05	Coupling Quick
43	532 19 60-65	Arm, Idler	--	532 18 72-92	Mandrel Asm. Service Mandrel Assembly (Includes housing, shaft assembly, and bearing only - pul- ley/nut/washer and blade bolt/ washers not included)
46	532 13 77-29	Screw, Thdroll. 1/4-20 x 5/8	--	532 41 82-29	Replacement Mower, Complete
47	532 19 61-03	Belt Deck Drive			
49	873 90 06-00	Nut, Lock Flg. 3/8-16 unc			
50	872 11 06-16	Bolt Rdhd Sqnk 3/8-16 unc x 2			
52	532 19 73-79	Pulley Idler			
58	532 18 73-42	Baffle Right			
59	532 18 73-44	Baffle Left			
60	532 18 76-07	Baffle Center			
97	532 17 85-15	Washer Hardened			

**NOTE:** All component dimensions given in U.S. inches.  
1 inch = 25.4 mm

**TRACTOR - MODEL NO. GTH26V54 (96048003500), PRODUCT NO. 960 48 00-35  
MOWER LIFT**

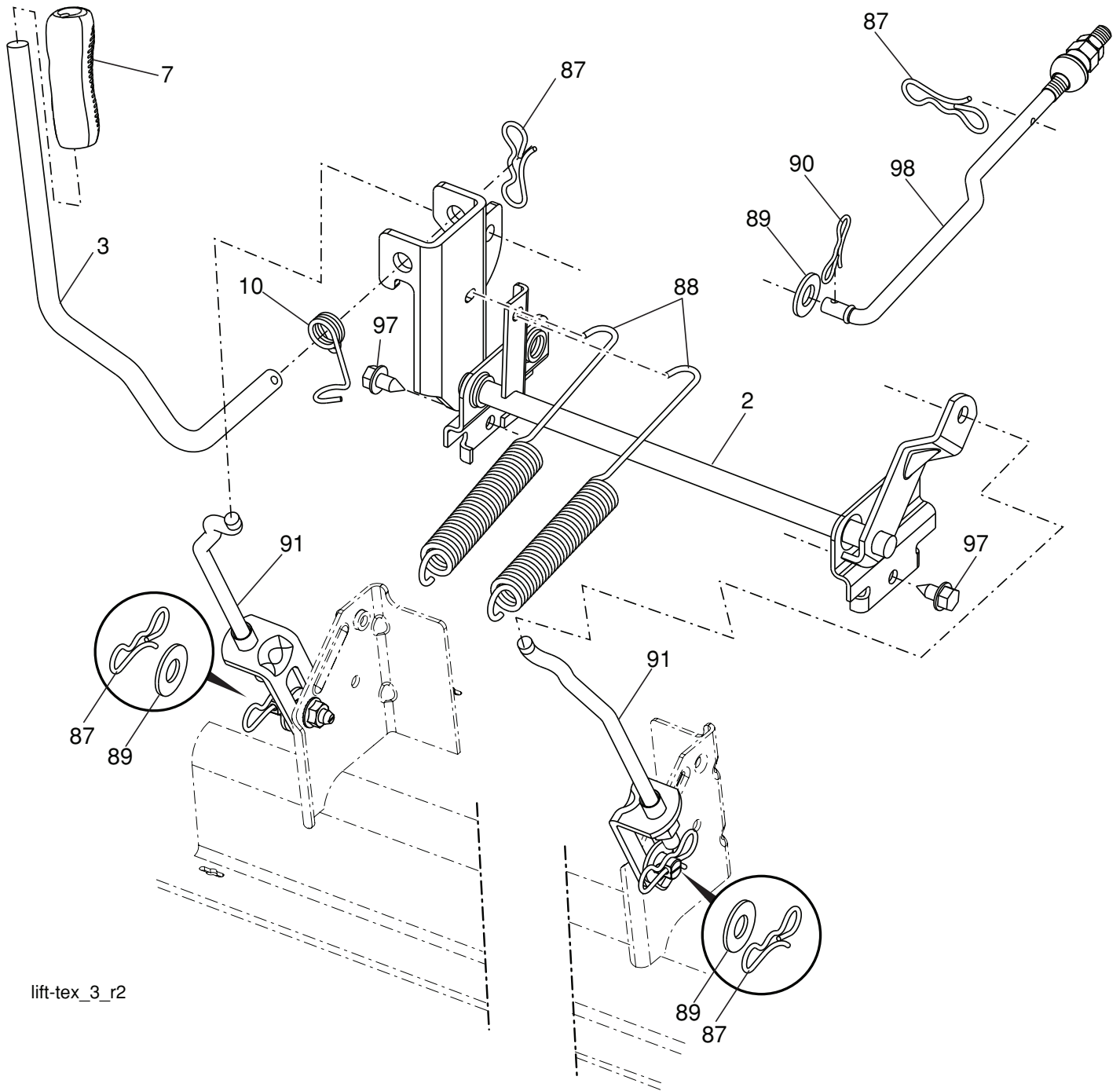

lift-tex\_3\_r2

KEY PART NO.	PART NO.	DESCRIPTION
2	532 42 20-27	Shaft Asm., Lift
3	532 19 52-30	Lever Asm., Lift RH
7	532 41 15-55	Grip, Lever
10	532 19 63-14	Spring Torsion
87	532 19 42-09	Pin Cotter 7/16 Bow Tie Lock
88	532 19 53-04	Spring Lift Assist
89	819 19 19-12	Washer Clear Zinc

KEY PART NO.	PART NO.	DESCRIPTION
90	532 19 42-08	Pin Cotter 5/16 Bow Tie Lock
91	532 40 34-07	Link Lift Susp Mower Rear
97	817 00 06-12	Screw 3/8-16 x 3/4
98	532 19 52-64	Link Lift Susp. Front Mower

**NOTE:** All component dimensions given in U.S. inches.  
1 inch = 25.4 mm



**TRACTOR - MODEL NO. GTH26V54 (96048003500), PRODUCT NO. 960 48 00-35  
SEAT ASSEMBLY**

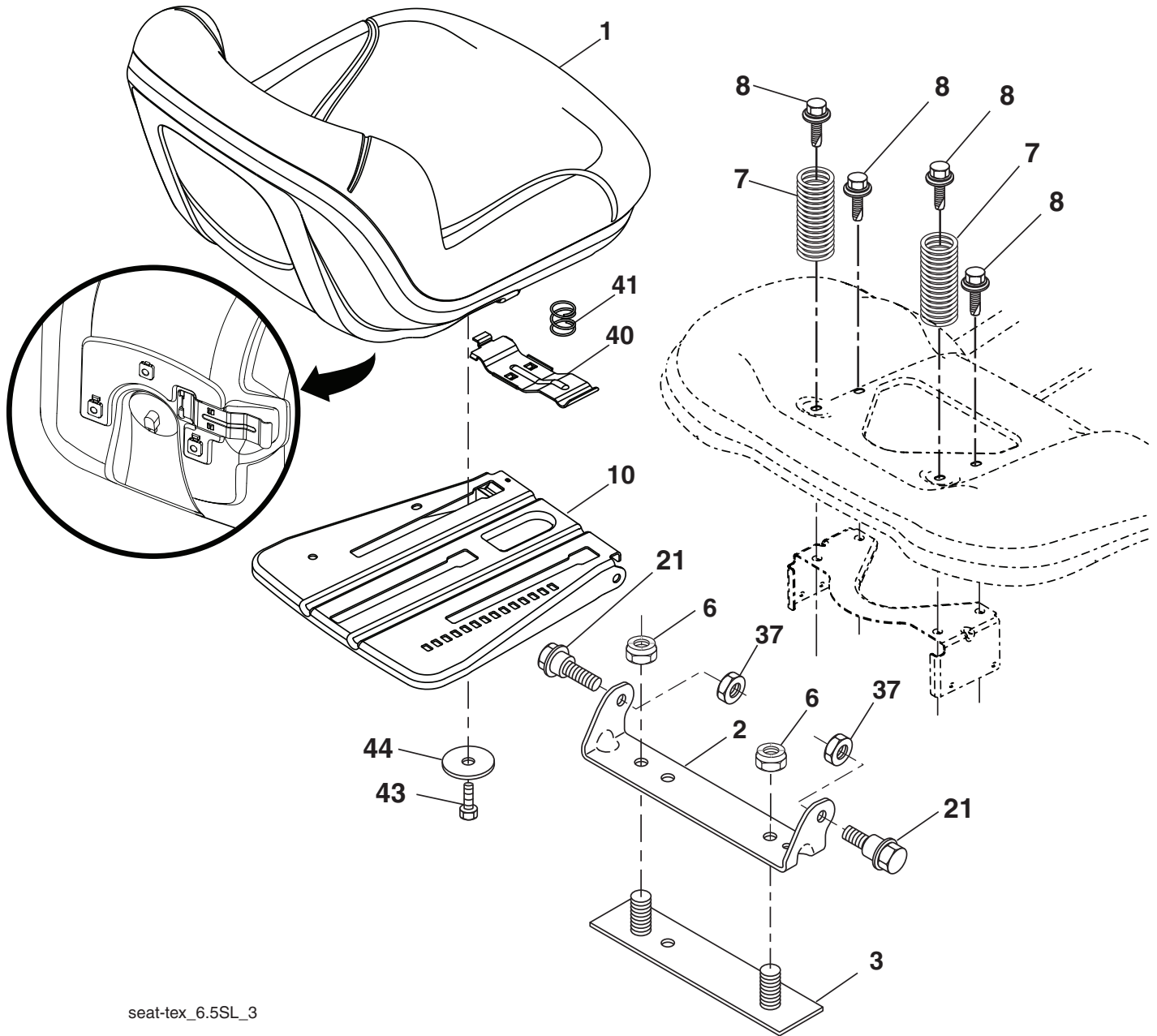

seat-tex\_6.5SL\_3

KEY NO.	PART NO.	DESCRIPTION
1	532 43 98-22	Seat
2	532 18 01-66	Bracket Pivot Fender
3	532 14 06-75	Strap, Asm Fender
6	873 80 06-00	Nut, Lock w/Ins. 3/8-16 unc
7	532 12 41-81	Spring, Seat Cprsn
8	532 17 18-77	Bolt 5/16-18 unc x 3/4 w/Sems
10	532 19 69-77	Pan, Seat
21	532 17 18-52	Bolt, Shoulder 5/16-18

KEY NO.	PART NO.	DESCRIPTION
37	873 80 05-00	Nut, Lock 5/16-18 unc
40	532 19 76-61	Handle Slide Seat
41	532 19 82-00	Spring Latch Seat
43	874 76 06-12	Bolt 3/8-16 x 3/4
44	819 13 38-12	Washer 13/32 x 2-3/8 x 12 Ga.

**NOTE:** All component dimensions given in U.S. inches.  
1 inch = 25.4 mm

**TRACTOR - MODEL NO. GTH26V54 (96048003500), PRODUCT NO. 960 48 00-35  
DECALS**

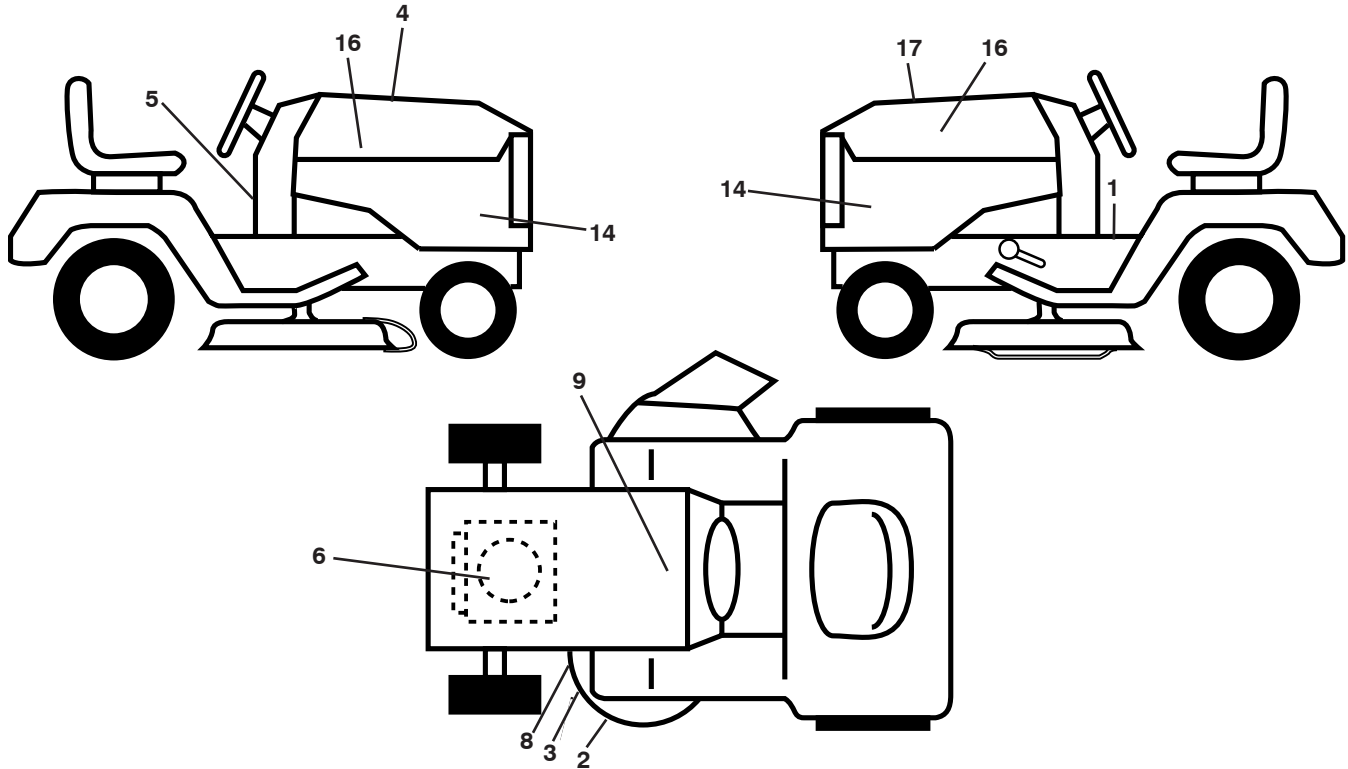

KEY PART NO.	NO.	DESCRIPTION
1	532 41 16-58	Decal, Fender Warning
2	532 19 87-85	Decal, Mower Sch.
3	532 17 05-63	Decal, Warning
4	532 42 38-29	Decal, Hood Cust Resp
5	532 43 52-86	Decal, Warning Spark Arrestor
6	532 43 50-97	Decal, Engine
8	532 17 84-55	Decal, Mower Caution
9	532 14 50-05	Decal, Battery Dnge/Poi

KEY PART NO.	NO.	DESCRIPTION
14	532 44 69-08	Decal, Panel Side
16	532 42 91-96	Decal, Hood Logo
17	532 44 68-04	Decal, Replacement
--	532 16 69-60	Decal, Bypass
--	532 43 98-82	Pad, Footrest, LH
--	532 44 15-42	Pad, Footrest, RH
--	532 44 69-18	Manual, Operator's (English/French)
--	532 44 69-19	Manual, Parts (English/ French)

**WHEELS AND TIRES**

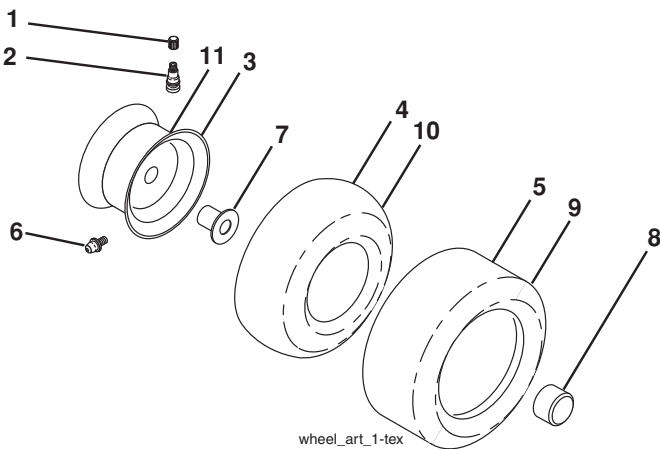

KEY PART NO.	NO.	DESCRIPTION
1	532 05 91-92	Cap, Valve, Tire
2	532 06 51-39	Stem, Valve
3	532 18 18-39	Rim Assembly, Front
4	532 00 81-34	Tube, Front (Service Item Only)
5	532 10 62-30	Tire, Front
6	532 12 49-57	Fitting, Grease (Front Wheel Only)
7	532 12 49-59	Bearing, Flange (Front Wheel Only)
8	532 17 50-39	Cap, Axle
9	532 10 55-88	Tire, Rear
10	532 00 71-54	Tube, Rear (Service Item Only)
11	532 14 45-10	Rim Assembly, Rear
--	532 14 43-34	Sealant, Tire (10 oz. Tube)

**NOTE:** All component dimensions given in U.S. inches.  
1 inch = 25.4 mm

