

Gasoline containing up to 10% ethanol (E10) is acceptable for use in this machine. The use of any gasoline exceeding 10% ethanol (E10) will void the product warranty.

Parts Manual

P-ZT26 BF / 966613701



Please read the operator's manual carefully and make sure you understand the instructions before using the machine.

When you need spare parts or support in service questions, warranty issues, etc., please consult the following professional:

This manual belongs to the machine with the manufacturing number:	Engine	Transmission

Manufacturing Number

The machine's manufacturing number can be found on the printed plate affixed to the engine compartment.

Stated on the plate, from the top are:

- The machine's type designation (I.D.).
- The manufacturer's type number (Model).
- The machine's serial number (Serial no.)

Please have the type designation and serial number available when ordering spare parts.

The engine's manufacturing number is stamped on one of the valve covers.

The plate states:

- The engine's model.
- The engine's type.
- Code

Please have these available when ordering spare parts.

The wheel motors and hydrostatic pumps have a barcode decal affixed at the rear.

CONTENTS

FRAME	4
ENGINE PLATE.....	6
STEERING	8
IGNITION SYSTEM.....	10
PARKING BRAKE	12
HYDRAULIC PUMP-MOTOR.....	14
HYDRAULIC FRAME	16
WHEELS AND TIRES	18
MOWER LIFT / DECK LIFT.....	20
MOWING DECK / CUTTING DECK	
48" DECK.....	22
52" DECK.....	24
61" DECK.....	26
SEAT	28
DECALS	30
PROTECTION FRAME	32
ACCESSORIES	
BLOWER	34
HOOD AND MOUNTS	36
GUARDS AND WEIGHTS	38
MULCH KIT.....	40

NOTE: ALL FASTENERS ARE GRADE 5 UNLESS OTHERWISE SPECIFIED.

FRAME

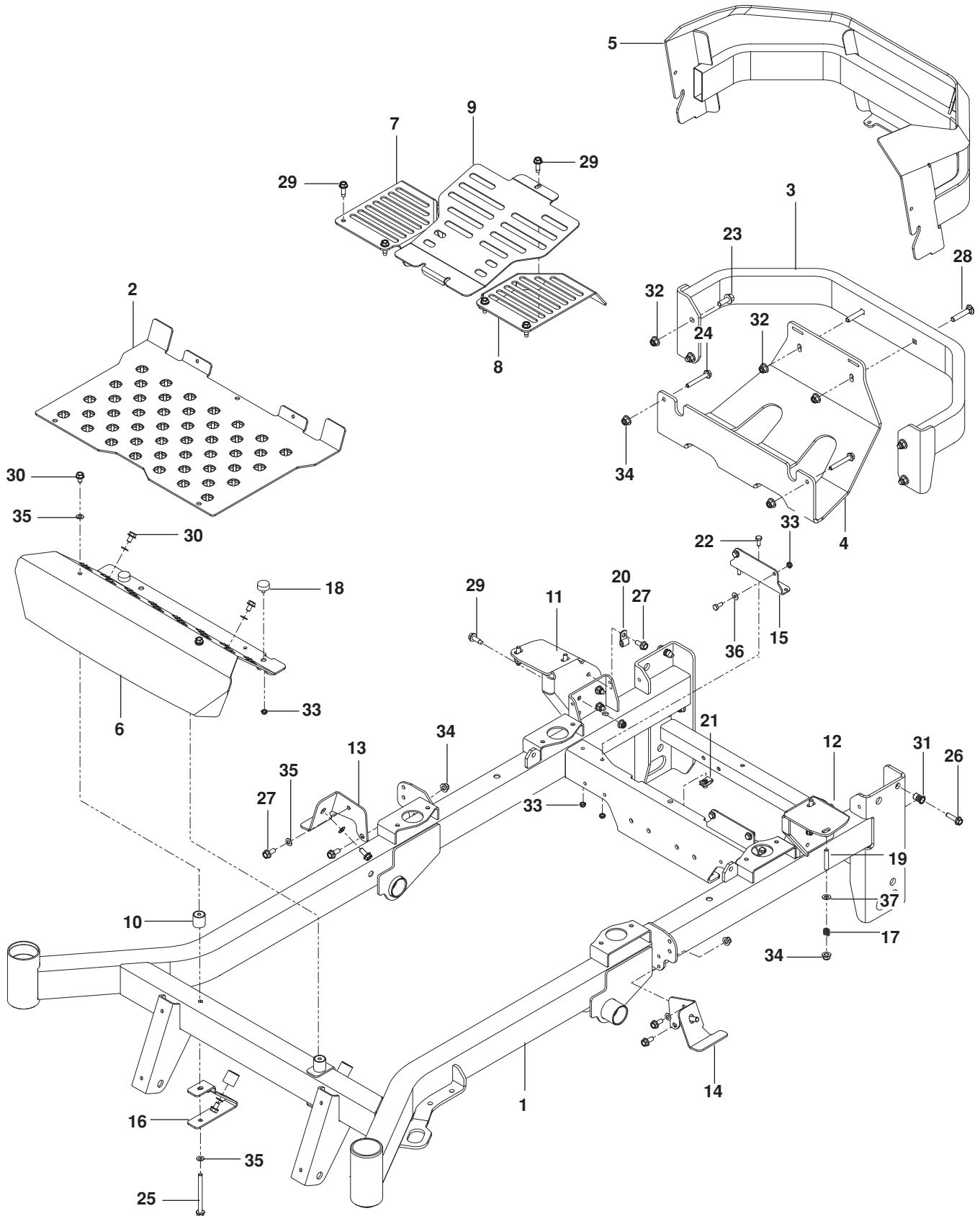

FRAME

ITEM	PART NO.	QTY.	DESCRIPTION	ITEM	PART NO.	QTY.	DESCRIPTION
1..	574 482801.....	1..	FRAME w/ SFTY DECAL ORG	20..	539 109867.....	1..	CLAMP, DOUBLE TUBE
2..	576 701302.....	1..	FLOOR PAN ORG	21..	539 104763.....	1..	RETAINER, U TYPE
3..	522 738902.....	1..	BUMPER, REAR ORG	22..	539 990072.....	8..	HCS 1/4-20 X 5/8
4..	576 701402.....	1..	PLATE, SKID GRY	23..	525 612801.....	4..	HHFS 3/8-16 x 1 HEX FLG
5..	574 433002.....	1..	GUARD, REAR GRY	24..	574 233801.....	2..	HHFS 5/16-18 x 2 1/4 HEX FLG
6..	574 215702.....	1..	FOOTREST ORG	25..	539 131780.....	2..	HHFS 5/16-18 x 3 3/4 HEX FLG
7..	576 701502.....	1..	COVER, FAN RT BLK	26..	525 544001.....	2..	HHFS 5/16-18 x 1 1/4 TPBLT
8..	576 701602.....	1..	COVER, FAN LT BLK	27..	525 464701.....	7..	HHFS 5/16-18 x 3/4 HEX FLG
9..	576 701702.....	1..	COVER, CENTER BLK	28..	539 100145.....	2..	RHSNB 3/8-16 x 2
10..	510 083201.....	4..	MOUNT, F/F INSERT	29..	539 113226.....	11..	BOLT 5/16-18 x 1 THD FRM
11..	529 279603.....	1..	MOUNT, TANK RT RR	30..	539 990858.....	6..	SCREW 5/16-18 x 1/2 SLF TAP
12..	529 279703.....	1..	MOUNT, TANK LT RR	31..	539 111028.....	2..	NUTSERT 5/16-18
13..	529 279903.....	1..	MOUNT, TANK RT FRT	32..	521 996501.....	2..	NUT 3/8-16 HEX FLG NYLOC
14..	529 280003.....	1..	MOUNT, TANK LT FRT	33..	539 108120.....	10..	NUT 1/4-20 HEX THIN NYLOC
15..	576 453602.....	2..	MOUNT, TANK BLK	34..	539 112899.....	14..	NUT 5/16-18 HEX FLG NYLOC
16..	510 040301.....	2..	BRACKET, REST MOUNT	35..	539 109600.....	8..	WASHER 5/16 DISC SPRING
17..	539 102845.....	4..	SPRING, TANK MOUNT	36..	539 990055.....	4..	WASHER 1/4 SAE FLAT
18..	575 811501.....	2..	BUMPER, 1/4-20 STUD 3/8"	37..	539 990188.....	4..	WASHER 5/16 SAE FLAT
19..	539 102502.....	4..	STUD, FUEL TANK				

ENGINE PLATE

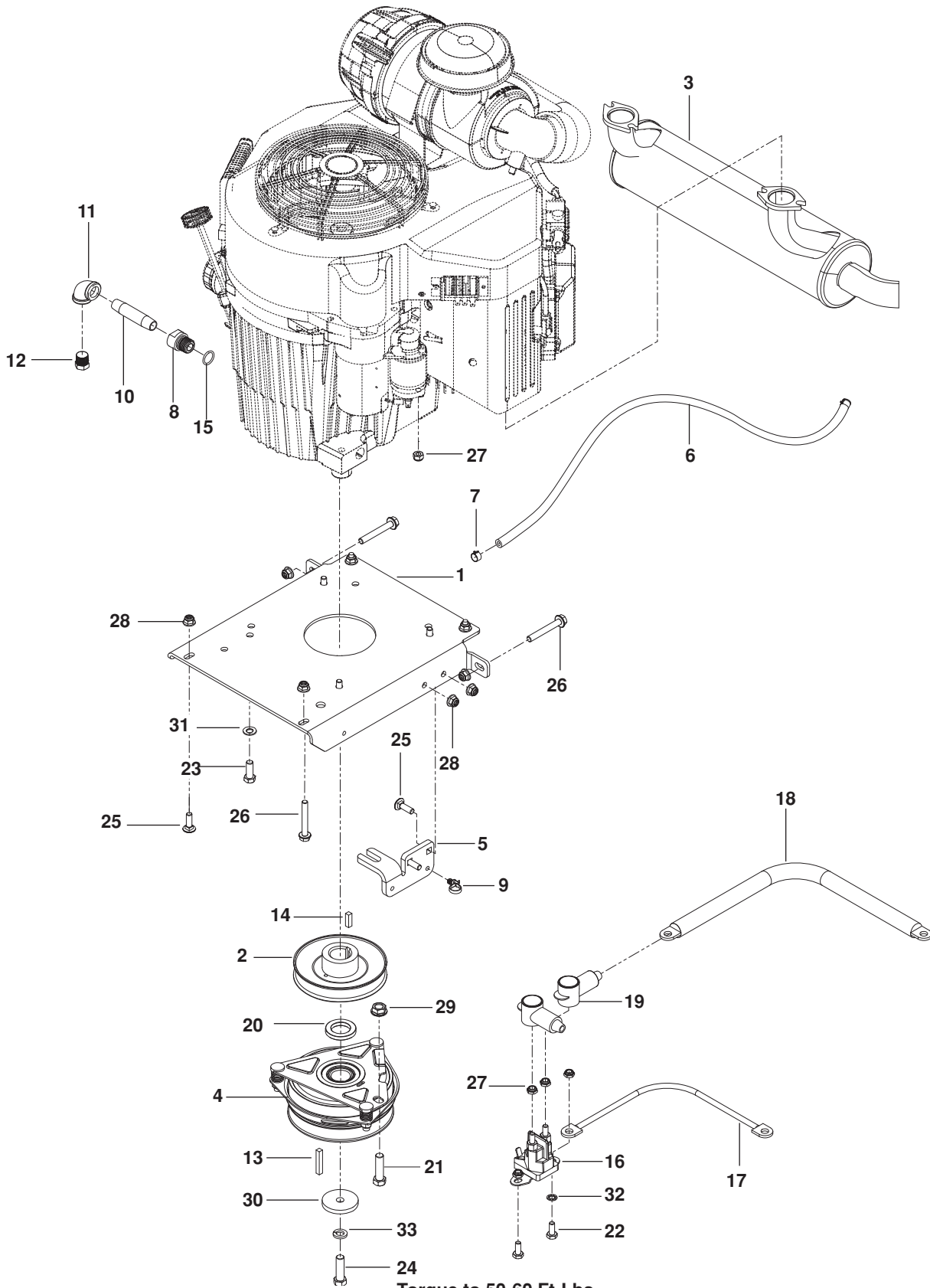

Torque to 50-60 Ft-Lbs

ENGINE PLATE

ITEM	PART NO.	QTY.	DESCRIPTION	ITEM	PART NO.	QTY.	DESCRIPTION
1..	510 004602.....	1..	PLATE, ENGINE BLK	19..	539 102759.....	2..	INSULATOR
2..	510 019801.....	1..	PULLEY, ENGINE	20..	525 313901.....	1..	SPACER
3..	525 750201.....	1..	MUFFLER	21..	539 104867.....	1..	HCS 7/16-14 x 1 1/4 HEX NYLOC
4..	539 113437.....	1..	CLUTCH, GT 3.5	22..	539 990072.....	2..	HCS 1/4-20 x 5/8
5..	522 676702.....	1..	STOP, CLUTCH	23..	539 990563.....	4..	HCS 3/8-16 x 1 HEX NYLOC
6..	539 105526.....	1..	FUEL LINE 18"	24..	539 100141.....	1..	HCS 7/16-20 x 1 1/2 HEX NYLOC
7..	539 912222.....	2..	CLAMP	25..	539 990208.....	4..	RHSNB 5/16-18 x 1
8..	539 119680.....	1..	ADAPTOR, OIL DRAIN	26..	574 233801.....	3..	HHFS 5/16-18 x 2 1/4 HEX FLG
9..	505 280001.....	1..	TIE WRAP w/ CLIP	27..	539 108120.....	5..	NUT 1/4-20 HEX THIN NYLOC
10..	539 118911.....	1..	PIPE 3/8 NPT x 3"	28..	539 112899.....	8..	NUT 5/16-18 HEX FLG NYLOC
11..	539 105072.....	1..	ELBOW 90°	29..	539 102582.....	1..	NUT 7/16-14 HEX WHIZ LK
12..	522 837001.....	1..	PLUG 3/8 NPTF DRAIN	30..	539 125626.....	1..	WASHER, BLADE
13..	539 910210.....	1..	KEY 1/4 SQ x 2	31..	539 102593.....	4..	WASHER 3/8 SPRING
14..	539 105308.....	1..	KEY 1/4 SQ x 1	32..	539 990053.....	1..	WASHER 1/4 INT TOOTH LK
15..	539 109618.....	1..	O-RING	33..	539 990247.....	1..	WASHER 7/16 SLW
16..	539 101714.....	1..	SOLENOID	NOT SHOWN			
17..	539 105409.....	1..	GROUND WIRE		525 554201.....	1..	ENGINE HARNESS, KAW
18..	539 102757.....	1..	CABLE, POSITIVE				

STEERING

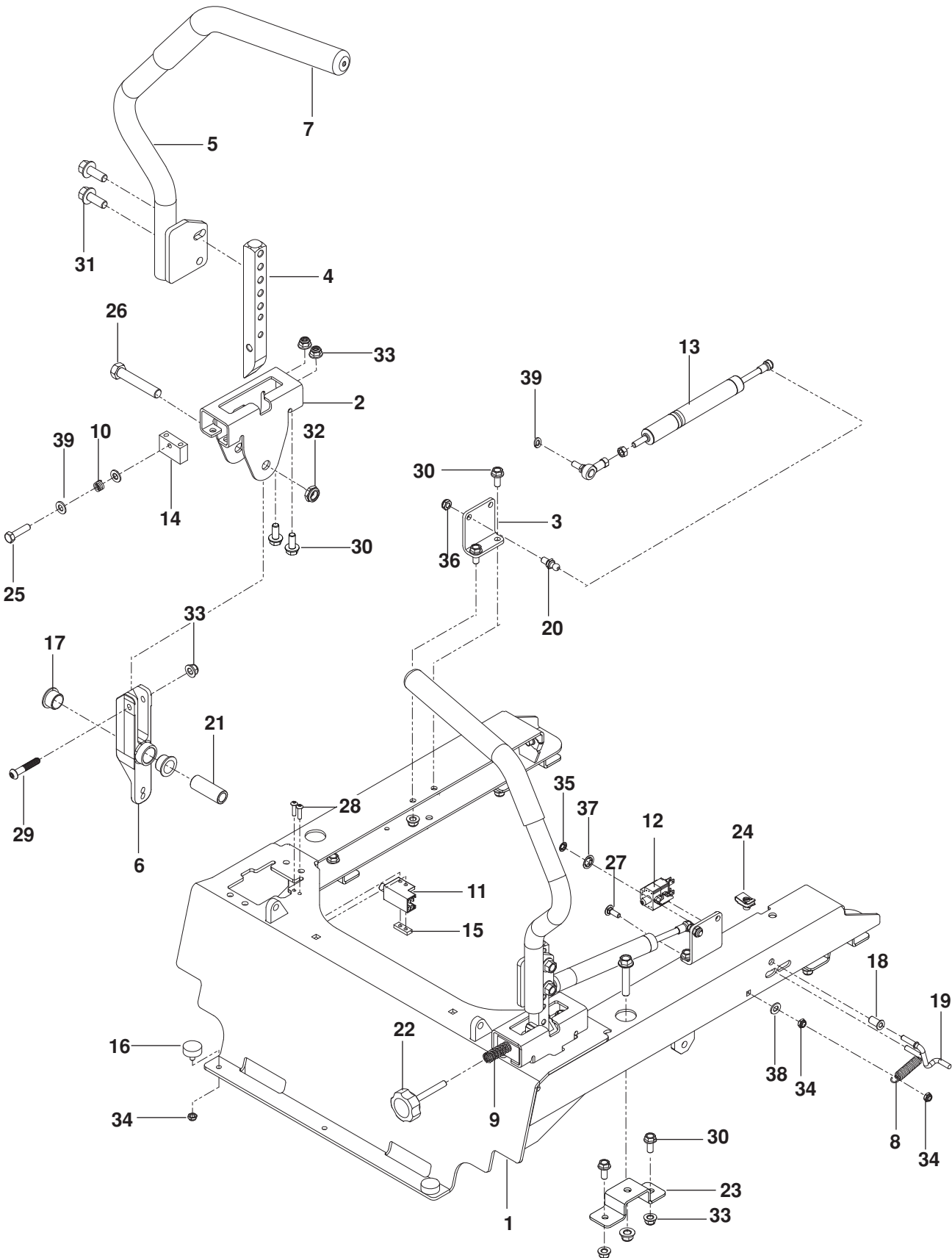

STEERING

ITEM	PART NO.	QTY.	DESCRIPTION	ITEM	PART NO.	QTY.	DESCRIPTION
1..	577 327702.....	1..	FRAME, SEAT MOUNT ORG	22..	539 131799.....	1..	KNOB
2..	577 251701.....	2..	BRACKET, CONTROL	23..	522 849702.....	4..	MOUNT, BLK
3..	577 265801.....	2..	BRACKET, DAMPENER	24..	539 104763.....	4..	RETAINER, U TYPE
4..	574 269401.....	2..	LEVER, MOTION	25..	539 100469.....	1..	HCS 5/16-18 x 1 1/4 TPBLT
5..	577 042403.....	1..	LEVER, w/ GRIP, RT	26..	539 101332.....	2..	HCS 1/2-13 x 2 3/4
	577 042303.....	1..	LEVER, w/ GRIP, LT	27..	539 990074.....	1..	RHSNB 1/4-20 x 3/4 GR2
6..	576 140302.....	2..	LEVER, CONTROL	28..	574 822701.....	4..	SCREW 10-24 x 3/4 SKT HD
7..	539 130894.....	2..	GRIP, LEVER	29..	576 850402.....	2..	SCREW 5/16-18 x 1 3/4 BTN HD
8..	539 020035.....	1..	SPRING	30..	525 464701.....	20..	HHFS 5/16-18 x 3/4 HEX FLG
9..	576 850301.....	1..	SPRING	31..	525 612801.....	4..	HHFS 3/8-16 x 1 HEX FLG
10..	539 102845.....	1..	SPRING	32..	539 108010.....	2..	NUT 1/2-13 HEX JAM NYL GR2
11..	532 109553.....	2..	SWITCH	33..	539 112899.....	20..	NUT 5/16-18 HEX FLG NYLOC
12..	539 113792.....	1..	SWITCH, BRAKE (3-POLE)	34..	539 108120.....	4..	NUT 1/4-20 HEX THIN NYLOC
13..	516 020301.....	2..	DAMPENER ASSY	35..	539 102234.....	1..	NUT 1/4 PUSH
14..	577 251801.....	2..	BLOCK, TRACKING	36..	539 990717.....	2..	NUT 5/16-18 HEX NYLOC
15..	539 131519.....	2..	PLATE, TAPPED	37..	539 913847.....	2..	NUT 3/8 RETAINER
16..	575 811501.....	2..	BUMPER	38..	539 990188.....	3..	WASHER 5/16 SAE FLAT
17..	539 131518.....	4..	BEARING, FLANGE	39..	539 990187.....	2..	WASHER 5/16 SLW
18..	511 594901.....	1..	BUSHING 1/4 FLANGE				NOT SHOWN
19..	511 595001.....	1..	LINK, SWITCH		510 093601.....	1..	HARNES, MAIN WIRING
20..	539 110607.....	2..	BALL STUD 10MM				
21..	577 252401.....	2..	SPACER, PIVOT				

IGNITION SYSTEM

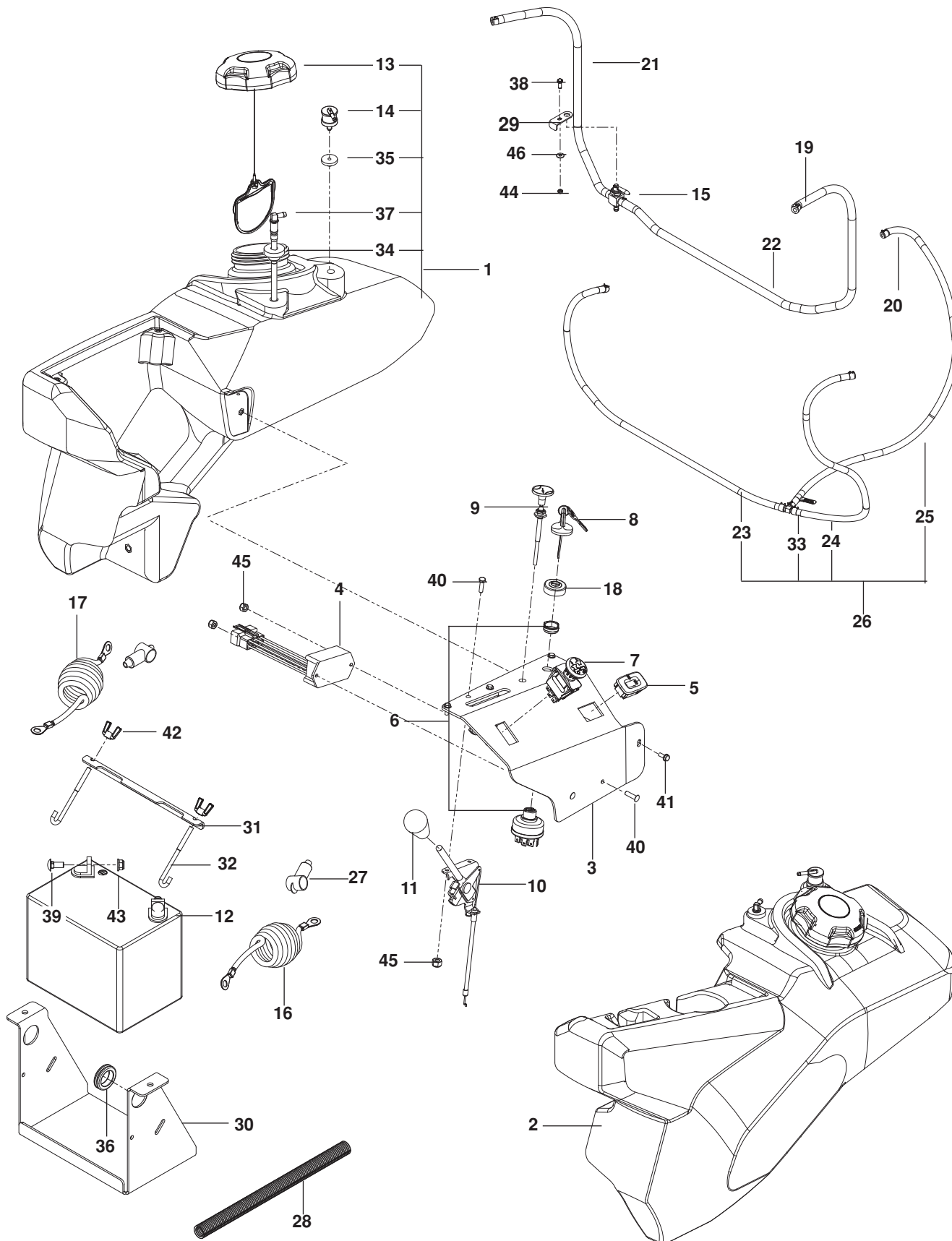

IGNITION SYSTEM

ITEM	PART NO.	QTY.	DESCRIPTION	ITEM	PART NO.	QTY.	DESCRIPTION
1..	576 369202.....	1..	TANK ASSY, RT GRY	24..	576 660601.....	1..	HOSE ³ / ₁₆ 39"
2..	576 369102.....	1..	TANK ASSY, LT GRY	25..	576 660604.....	1..	HOSE ³ / ₁₆ 30"
3..	529 280202.....	1..	PANEL, CONTROL	26..	576 547701.....	1..	VAPOR LINE ASSY
4..	574 514001.....	1..	TIMER, SEAT	27..	539 102759.....	2..	INSULATOR
5..	576 179401.....	1..	HOUR METER	28..	574 235301.....	1..	LOOM ⁵ / ₈ SPLIT
6..	574 455401.....	1..	SWITCH, IGNITION	29..	577 104002.....	1..	BRACKET, VALVE
7..	539 131627.....	1..	SWITCH, PTO 10 AMP	30..	510 029902.....	1..	BRACKET, BATTERY BLK
8..	574 455501.....	1..	KEY, IGNITION	31..	510 030001.....	1..	BRACKET, BATTERY MOUNT
9..	574 206901.....	1..	CABLE, CHOKE	32..	510 064001.....	2..	J HOOK
10..	574 207001.....	1..	CABLE, THROTTLE	33..	574 206602.....	1..	TEE ³ / ₁₆ FUEL LINE
11..	539 132624.....	1..	KNOB	34..	539 105245.....	2..	GROMMET, RUBBER
12..	539 102436.....	1..	BATTERY	35..	576 618201.....	2..	GROMMET, CHECK VALVE
13..	575 018101.....	2..	CAP w/ TETHER, FUEL	36..	539 105974.....	1..	GROMMET
14..	576 618101.....	2..	VALVE, FUEL CHECK	37..	525 865401.....	2..	FITTING, FUEL
15..	539 102679.....	1..	VALVE, FUEL	38..	539 990580.....	1..	HCS ¹ / ₄ -20 x ³ / ₄
16..	522 718701.....	1..	CABLE, POSITIVE	39..	539 990316.....	2..	RHSNB ⁵ / ₁₆ -18 x ³ / ₄
17..	522 710701.....	1..	CABLE, NEGATIVE	40..	574 822701.....	4..	SCREW 10-24 x ³ / ₄ SKT HD
18..	539 103178.....	1..	CAP, IGNITION SWITCH	41..	539 114341.....	3..	SCREW 10-24 x ³ / ₈ SKT HD
19..	539 912222.....	4..	CLAMP, HOSE	42..	539 990997.....	2..	WINGNUT ¹ / ₄ -20 NYLOC
20..	575 436501.....	6..	CLAMP, HOSE	43..	539 112899.....	2..	NUT ⁵ / ₁₆ -18 HEX FLG NYLOC
21..	577 103901.....	1..	LINE 22" FUEL	44..	539 108120.....	1..	NUT ¹ / ₄ -20 HEX THIN NYLOC
22..	577 103902.....	1..	LINE 38" FUEL	45..	539 976977.....	4..	NUT 10-24 HEX NYLOC
23..	576 660603.....	1..	HOSE ³ / ₁₆ 21"	46..	539 990598.....	1..	WASHER ¹ / ₄ FLAT

PARKING BRAKE

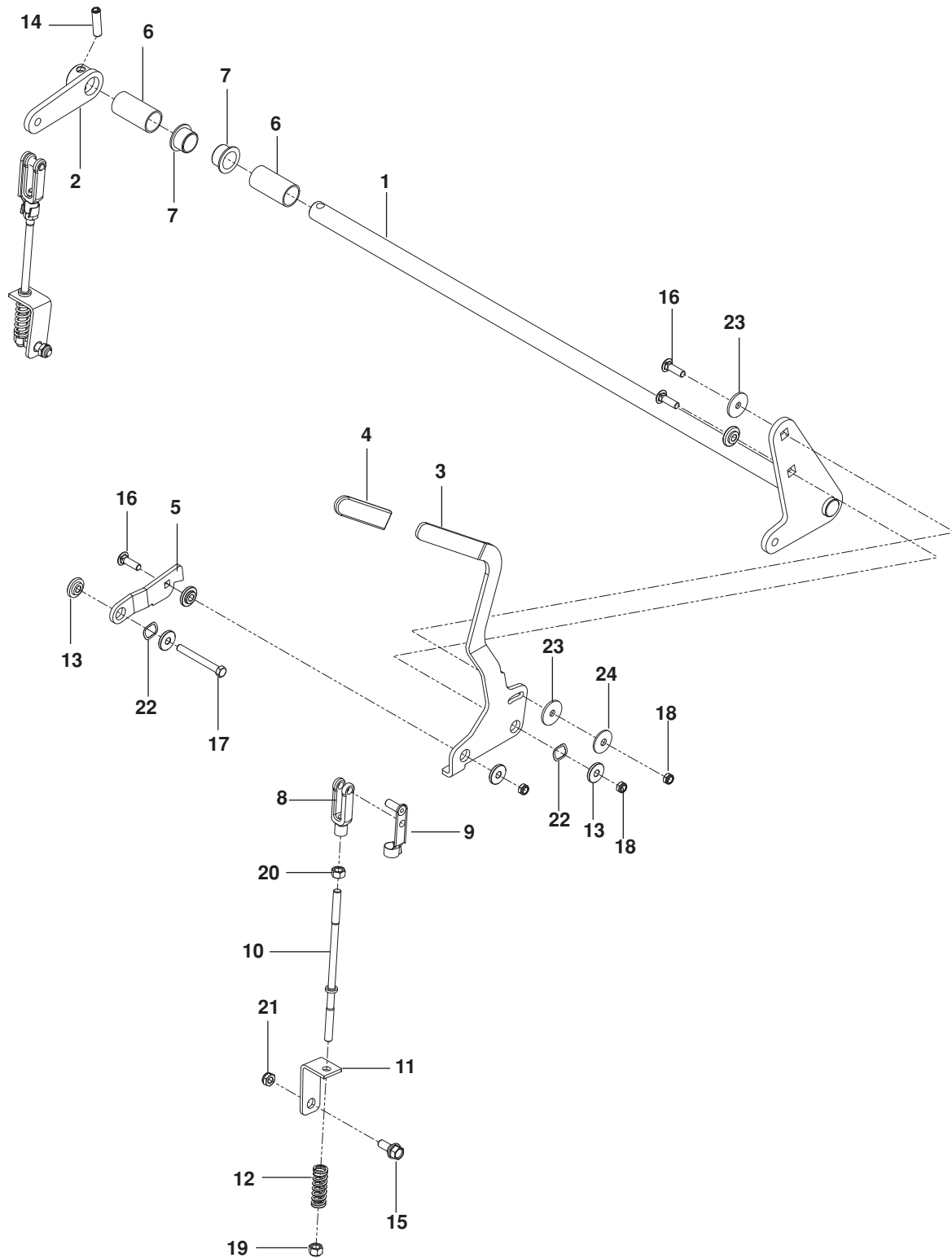

PARKING BRAKE

ITEM	PART NO.	QTY.	DESCRIPTION	ITEM	PART NO.	QTY.	DESCRIPTION
1..	576 416301.....	1..	SHAFT, BRAKE	13..	539 132161.....	6..	BUSHING, BRAKE
2..	576 416401.....	1..	ARM, RT BRAKE	14..	539 110631.....	1..	ROLL PIN ⁵ / ₁₆ " DIA.
3..	515 980002.....	1..	LEVER, BRAKE	15..	539 110303.....	2..	BOLT ⁵ / ₁₆ SHOULDER
4..	539 976526.....	1..	GRIP, LEVER	16..	539 100413.....	3..	RHSNB ³ / ₈ -16 x 1 ¹ / ₄
5..	515 980301.....	1..	LINK, FOLLOWER	17..	539 923463.....	1..	HHFS ³ / ₈ -16 x 3 ¹ / ₄
6..	576 764001.....	2..	SPACER, SHAFT	18..	539 200282.....	3..	NUT ³ / ₈ -16 HEX JAM NYLOC
7..	539 131518.....	2..	BEARING, FLANGE	19..	539 110943.....	2..	NUT ⁵ / ₁₆ -24 HEX NYLOC
8..	539 976481.....	2..	YOKE	20..	539 990223.....	2..	NUT ⁵ / ₁₆ -24 HEX
9..	522 705902.....	2..	CLEVIS SPRING	21..	539 115617.....	2..	NUT ⁵ / ₁₆ -18 HEX NYLOC
10..	576 459501.....	2..	LINKAGE, BRAKE	22..	539 133007.....	2..	WASHER, WAVE
11..	575 229802.....	2..	BRACKET, BRAKE	23..	525 490901.....	2..	WASHER, FRICTION
12..	575 230301.....	1..	SPRING	24..	539 912063.....	1..	WASHER, CONE

HYDRAULIC PUMP-MOTOR

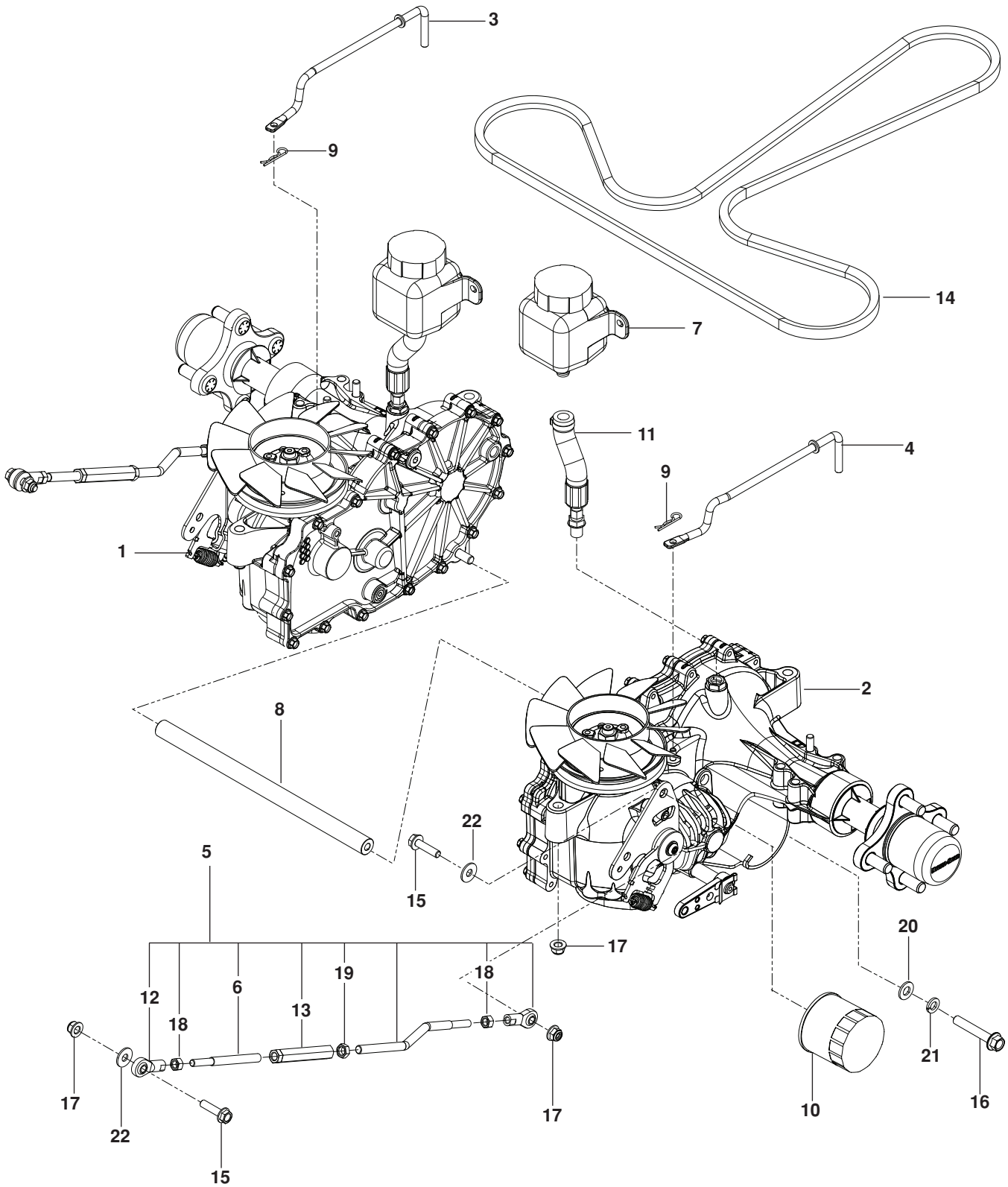

HYDRAULIC PUMP-MOTOR

ITEM	PART NO.	QTY.	DESCRIPTION	ITEM	PART NO.	QTY.	DESCRIPTION
1..	574 569102.....	1..	TRANS, ZT-3400, RT	12..	539 102590.....	4..	BALL END, RT
2..	574 569101.....	1..	TRANS, ZT-3400, LT	13..	539 109149.....	2..	TURNBUCKLE 3/8
3..	539 131618.....	1..	LINKAGE, RT BYPASS	14..	576 667201.....	1..	BELT
4..	539 131616.....	1..	LINKAGE, LT BYPASS	15..	525 544001.....	4..	HHFS 5/16-18 x 1 1/4 TPBLT
5..	576 415701.....	2..	LINKAGE, CONTROL ASSY	16..	539 108551.....	4..	HCS 3/8-16 x 2 1/4 GR8
6..	522 559201.....	2..	LINKAGE, CONTROL FT	17..	539 112899.....	6..	NUT 5/16-18 HEX FLG NYLOC
7..	574 811301.....	2..	TANK, EXPANSION	18..	539 990223.....	4..	NUT 5/16-24 HEX
8..	576 422701.....	1..	SHAFT, TIE ROD	19..	539 108732.....	2..	NUT 3/8-24 HEX JAM
9..	539 976988.....	2..	HAIRPIN COTTER	20..	539 990122.....	2..	WASHER 3/8 SAE FLT
10..	539 113466.....	2..	FILTER, HYDRO	21..	539 990118.....	2..	WASHER 3/8 SPLT LK
11..	576 943701.....	2..	HOSE, EXPANSION	22..	539 990692.....	4..	WASHER 5/16 STD FLT

HYDRAULIC FRAME

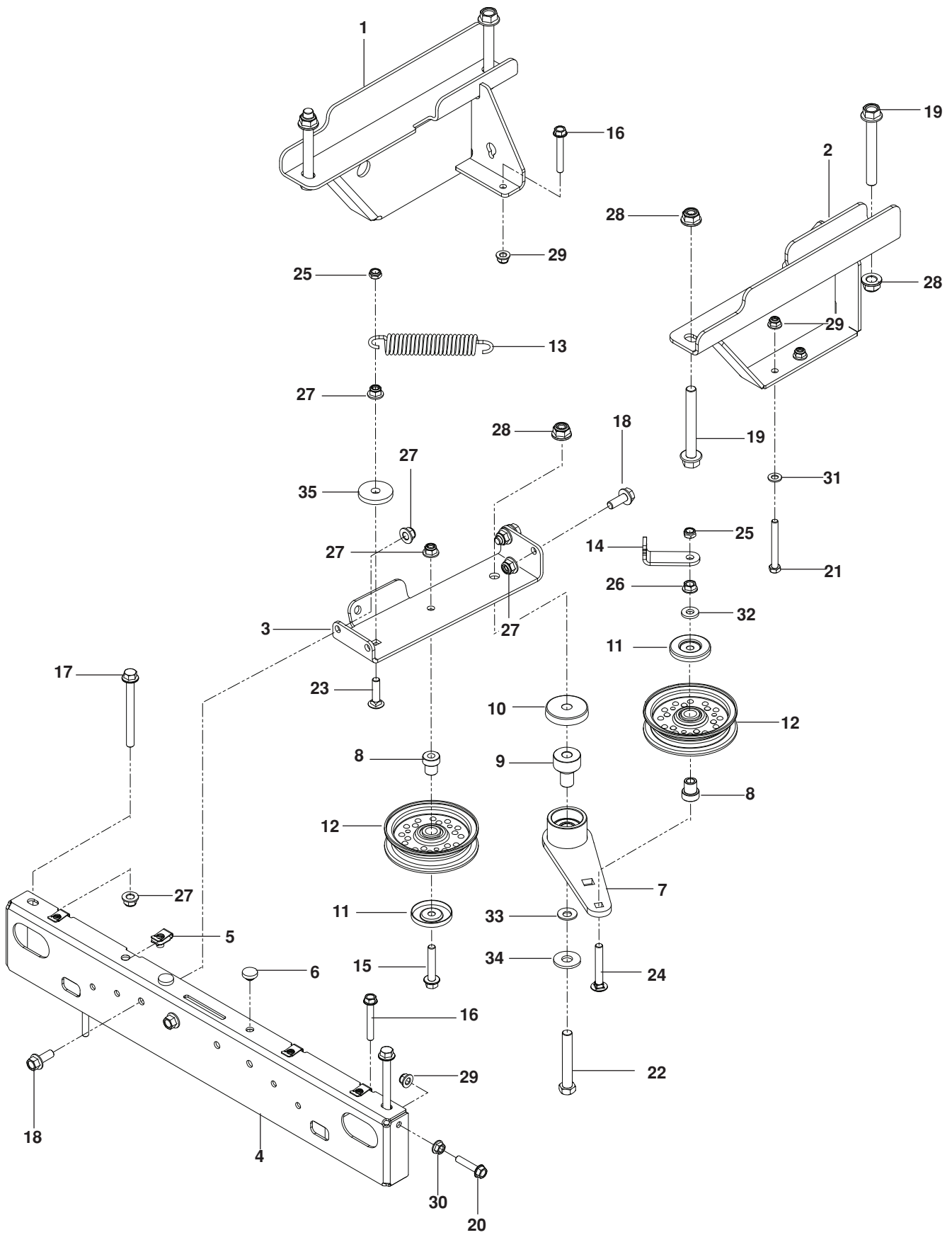

HYDRAULIC FRAME

ITEM	PART NO.	QTY.	DESCRIPTION	ITEM	PART NO.	QTY.	DESCRIPTION
1..	576 415802.....	1..	MOUNT, TRANS RT BLK	19..	525 544801.....	4..	HHFS ½-13 x 4 GR 8
2..	576 415902.....	1..	MOUNT, TRANS LT BLK	20..	525 465401.....	4..	HHFS 5/16-18 x 1½
3..	576 459902.....	1..	MOUNT, IDLER BLK	21..	539 101721.....	4..	HCS 5/16-18 x 2¾
4..	576 416203.....	1..	MOUNT, FT BLK	22..	539 103433.....	1..	HCS ½-13 x 3¼
5..	539 104763.....	4..	RETAINER, U TYPE	23..	539 109345.....	1..	RHSNB ¾-16 x 1½
6..	539 102587.....	2..	GROMMET, BUMPER	24..	539 128101.....	1..	BOLT ¾-16 x 2½ CARRIAGE
7..	510 041603.....	1..	ARM, IDLER w/ BEARINGS	25..	539 200282.....	2..	NUT ¾-16 HEX JAM NYLOC
8..	525 435601.....	2..	PIVOT, IDLER	26..	539 990613.....	1..	NUT ¾-16 HEX WHIZLK
9..	510 206301.....	1..	PIVOT, BEARING	27..	521 996501.....	8..	NUT ¾-16 HEX FLG NYLOC
10..	539 114662.....	1..	SHIELD, DUST	28..	521 991101.....	5..	NUT ½-13 HEX FLG NYLOC
11..	510 254501.....	2..	SHIELD, DUST	29..	539 112899.....	3..	NUT 5/16-18 HEX FLG NYLOC
12..	539 976688.....	2..	PULLEY, IDLER	30..	539 990585.....	1..	NUT 5/16-18 HEX WHIZLK
13..	575 470901.....	1..	SPRING, EXTENSION	31..	539 990188.....	4..	WASHER 5/16 SAE FLAT
14..	576 459801.....	1..	BRACKET, SPRING	32..	522 023401.....	1..	WASHER ¾ THICK
15..	525 866201.....	1..	HHFS ¾-16 x 2	33..	539 115528.....	1..	WASHER ½ BELLEVILLE
16..	574 233801.....	4..	HHFS 5/16-18 x 2¼ HEX FLG	34..	539 109554.....	1..	WASHER ½ FLAT
17..	521 996601.....	2..	HHFS ¾-16 x 4	35..	539 106504.....	1..	WASHER, HEAVY
18..	525 612801.....	4..	HHFS ¾-16 x 1				

WHEELS AND TIRES

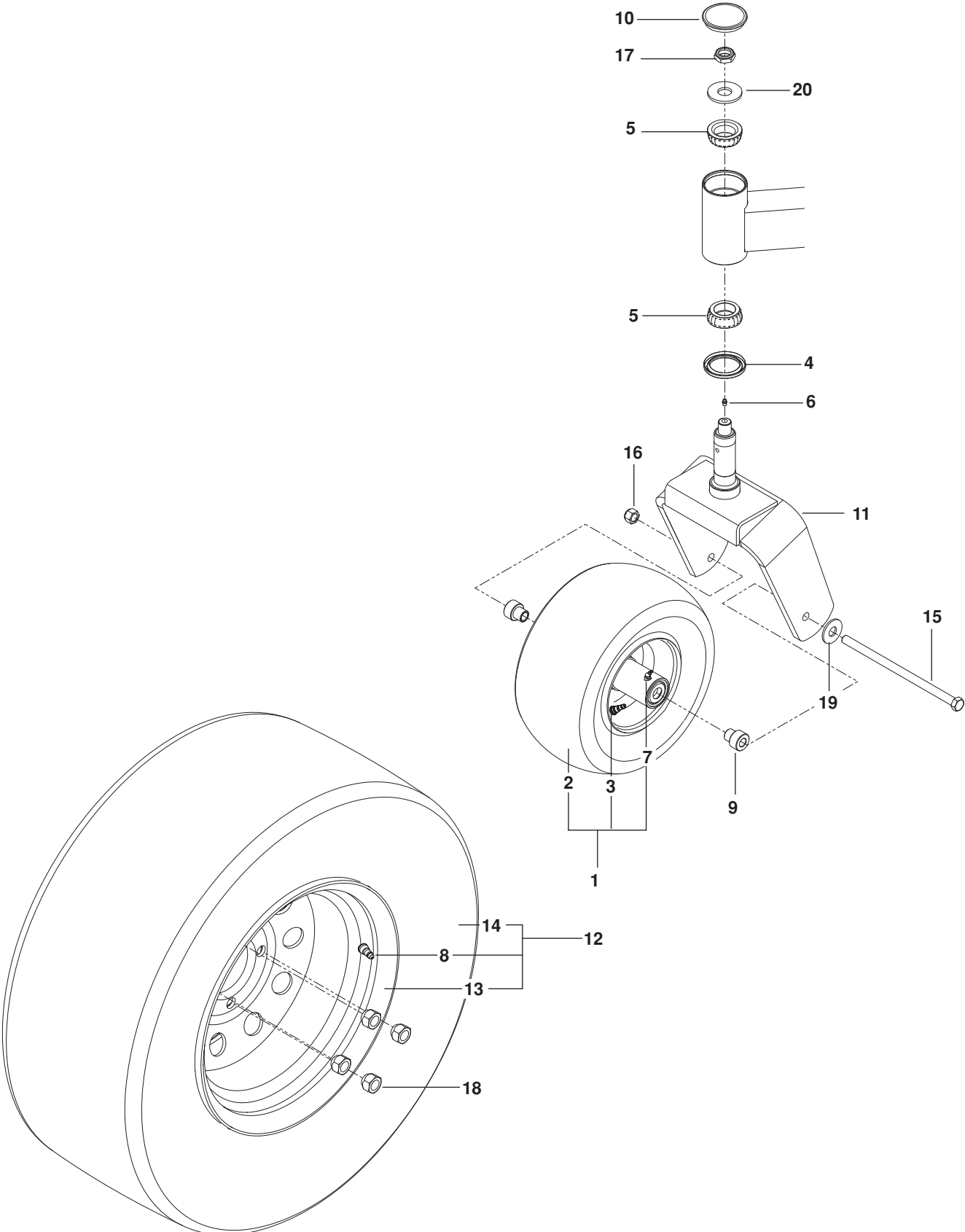

WHEELS AND TIRES

ITEM	PART NO.	QTY.	DESCRIPTION	ITEM	PART NO.	QTY.	DESCRIPTION
1..	539 105521.....	2..	TIRE ASSY 13 x 6.5	11..	525 611902.....	2..	FORK, CASTER
2..	539 105522.....	2..	TIRE	12..	522 905101.....	2..	TIRE ASSY 23 x 10.5
3..	539 105523.....	2..	RIM	13..	522 905102.....	2..	RIM 12 x 1.125 NEG OFFSET
4..	510 034301.....	2..	SEAL, BEARING	14..	539 107431.....	2..	TIRE 23 x 10.5 TURF MASTER
5..	510 034403.....	4..	CONE	15..	539 105517.....	2..	BOLT 1/2-13 x 9 1/2 HEX NYLOC
6..	539 101474.....	2..	ZERK	16..	521 991101.....	2..	NUT 1/2-13 HEX FLG NYLOC
7..	539 103300.....	2..	ZERK	17..	522 842601.....	2..	NUT 3/4-16 HEX THIN NYLOC
8..	539 912234.....	4..	STEM, VALVE	18..	539 101173.....	8..	NUT, LUG
9..	539 105518.....	4..	SPACER, AXLE	19..	539 990250.....	2..	WASHER 1/2 SAE
10..	510 034001.....	2..	CAP, DUST	20..	574 824701.....	2..	WASHER 3/4 HARDENED

MOWER LIFT / DECK LIFT

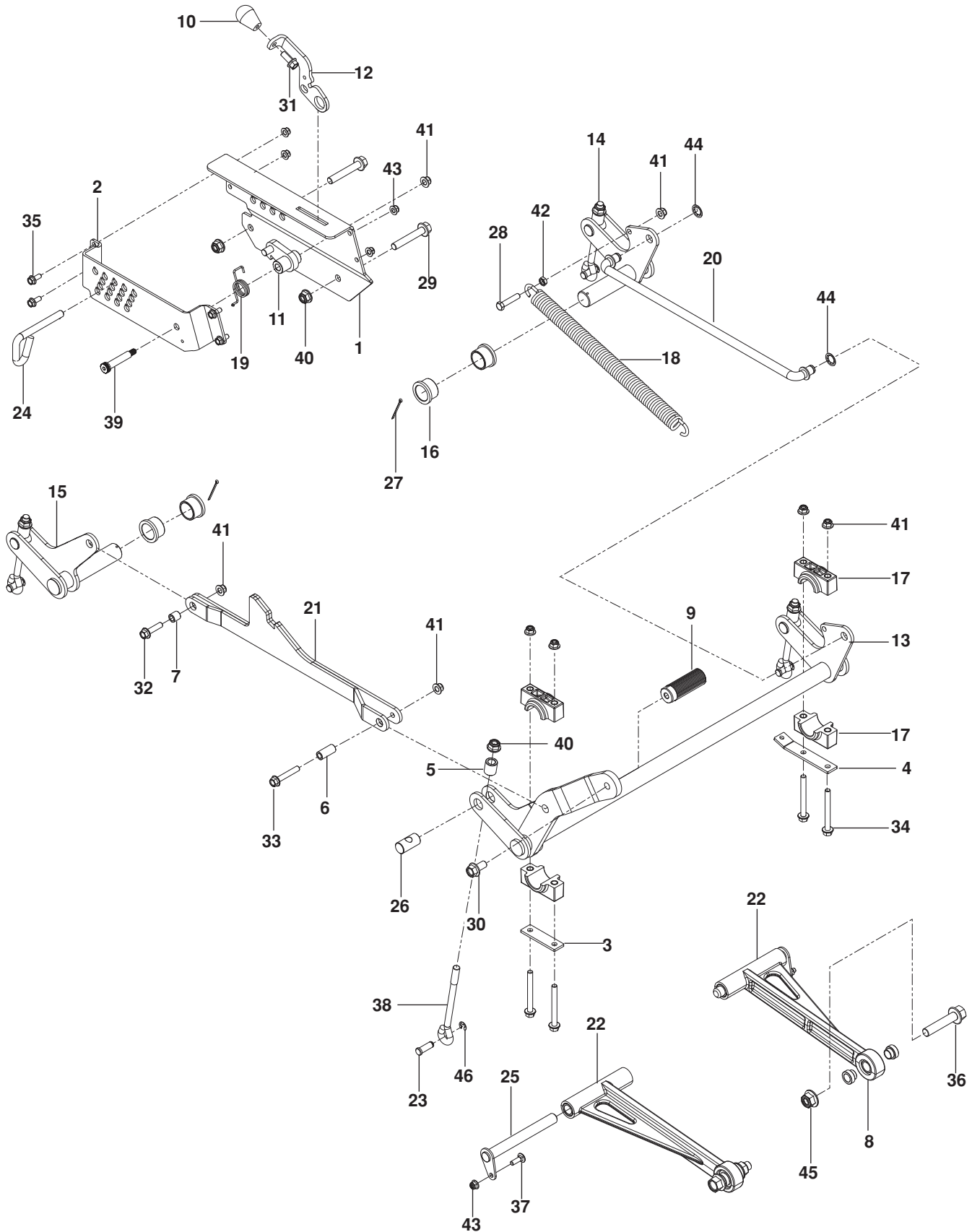

MOWER LIFT / DECK LIFT

ITEM	PART NO.	QTY.	DESCRIPTION	ITEM	PART NO.	QTY.	DESCRIPTION
1..	576 480002.....	1..	PLATE, HEIGHT, INNER ORG	24..	510 016501.....	1..	PIN, HEIGHT
2..	576 480102.....	1..	PLATE, HEIGHT, OUTER ORG	25..	515 988201.....	2..	PIN, STRUT
3..	525 822201.....	1..	PLATE, PILLOW BLOCK	26..	576 485601.....	4..	PIN, TRUNION
4..	576 646701.....	1..	PLATE, SPRING ANCHOR	27..	539 102889.....	2..	PIN 1/8 x 2 COTTER
5..	576 485801.....	4..	SPACER, EYEBOLT	28..	539 990730.....	1..	HCS 3/8-16 x 1 3/4
6..	576 623101.....	1..	SPACER, FRT LIFT STRAP	29..	525 828901.....	2..	HHFS 1/2-13 x 3
7..	576 623001.....	1..	SPACER, RR LIFT STRAP	30..	574 210601.....	1..	HHFS 1/2-13 x 1
8..	510 362501.....	4..	SPACER, STRUT	31..	525 612801.....	1..	HHFS 3/8-16 x 1
9..	510 408301.....	1..	PEDAL, DECK HEIGHT	32..	576 621601.....	1..	HHFS 3/8-16 x 1 1/2
10..	539 132624.....	1..	KNOB	33..	574 496901.....	1..	HHFS 3/8-16 x 2 1/4
11..	510 406801.....	1..	LATCH, TRANSPORT	34..	525 822101.....	4..	HHFS 3/8-16 x 3 1/2
12..	576 638901.....	1..	LEVER, RELEASE	35..	525 464701.....	4..	HHFS 5/16-18 x 3/4
13..	576 479201.....	1..	SHAFT, DECK LIFT FT	36..	525 829001.....	2..	HHFS 5/8-11 x 3 GD 8
14..	526 479901.....	1..	SHAFT, LIFT LT RR	37..	539 990208.....	2..	RHSNB 5/16-18 x 1
15..	526 479401.....	1..	SHAFT, LIFT RT RR	38..	576 479001.....	4..	EYEBOLT, DECK LIFT
16..	510 089401.....	4..	BUSHING, FLANGED	39..	516 035501.....	1..	BOLT 3/8-16 x 2 1/4 SHLDR
17..	510 023902.....	4..	BLOCK, PILLOW	40..	521 991101.....	6..	NUT 1/2-13 HEX FLG NYLOC
18..	576 676601.....	1..	SPRING, EXTENSION	41..	521 996501.....	8..	NUT 3/8-16 HEX FLG NYLOC
19..	510 376601.....	1..	SPRING, TORSION	42..	539 109332.....	1..	NUT 3/8-16 HEX JAM
20..	510 089801.....	1..	ROD, LIFT	43..	539 112899.....	6..	NUT 5/16-18 HEX FLG NYLOC
21..	576 622601.....	1..	STRAP, DECK	44..	539 109304.....	2..	NUT 5/8 PUSH
22..	510 106501.....	2..	STRUT ASSY	45..	525 829101.....	2..	NUT 5/8-11 FLG NYLOC
23..	510 090101.....	4..	PIN 7/16 CLEVIS	46..	522 705201.....	4..	E RING 7/16

MOWING DECK / CUTTING DECK

48" DECK

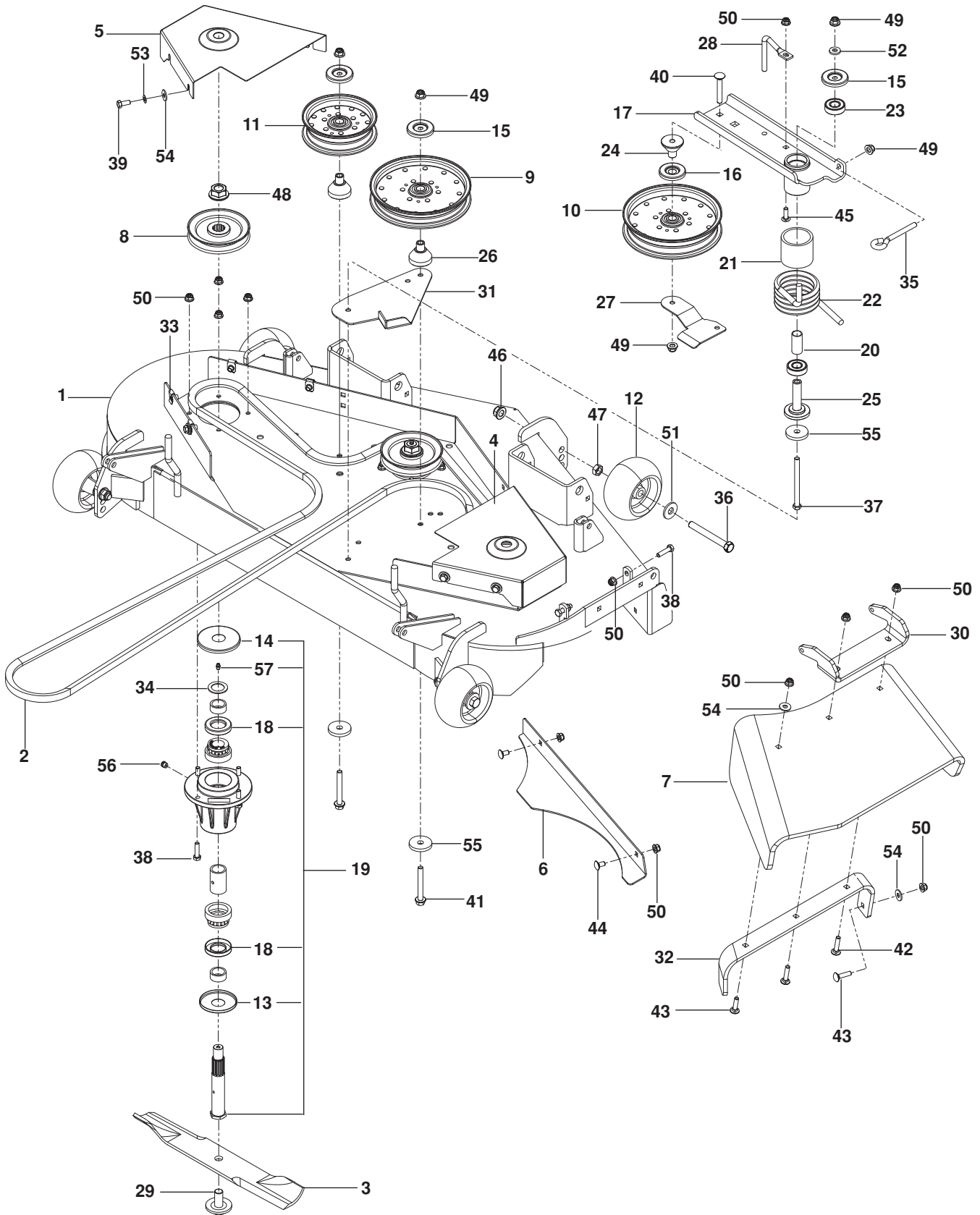

MOWING DECK / CUTTING DECK

ITEM	PART NO.	QTY.	DESCRIPTION	ITEM	PART NO.	QTY.	DESCRIPTION
1..	576 769201.....	1..	DECK w/ SFTY DECALS ORG	30..	539 130917.....	1..	BRACKET, PIVOT CHUTE
2..	576 479801.....	1..	BELT	31..	576 388702.....	1..	BRACKET, SPRING STOP BLK
3..	539 106040.....	3..	BLADE, 16¼"	32..	539 130920.....	1..	REINFORCEMENT, BRACKET
4..	539 113411.....	1..	BELT SHIELD , RT	33..	539 104763.....	8..	RETAINER, U TYPE
5..	539 113413.....	1..	BELT SHIELD, LT	34..	539 916561.....	3..	BUSHING 1" MACH 14 GA
6..	539 113427.....	1..	CONFINEMENT PLATE BLK	35..	574 202001.....	1..	EYE BOLT
7..	576 422501.....	1..	CHUTE, DISCHARGE	36..	539 108366.....	4..	HCS ½-13 x 4
8..	539 112141.....	3..	PULLEY	37..	539 101686.....	1..	HCS ¾-16 x 4½ GR 8
9..	510 015101.....	1..	PULLEY, IDLER 7"	38..	539 990627....	14..	HCS 5/16-18 x 1¼
10..	525 598201.....	1..	PULLEY, IDLER 7" NARROW	39..	539 976934.....	8..	HCS 5/16-18 x ¾
11..	539 103257.....	1..	PULLEY, IDLER	40..	539 128101.....	1..	BOLT ¾-16 x 2½ CARRIAGE
12..	539 107610.....	4..	WHEEL	41..	577 117701.....	2..	HHFS ¾-16 x 3
13..	539 108449.....	3..	DUST CAP, BOTTOM	42..	539 102933.....	2..	RHSNB 5/16-18 x 1½
14..	539 108450.....	3..	DUST CAP, TOP	43..	539 100472.....	2..	RHSNB 5/16-18 x 1¼
15..	510 254501.....	3..	SHIELD, DUST	44..	539 990799.....	2..	RHSNB 5/16-18 x 5/8
16..	510 262201.....	1..	SHIELD, DUST	45..	539 107271.....	1..	RHSNB 5/16-18 x 1
17..	525 464402.....	1..	ARM, IDLER BLK	46..	521 991101.....	4..	NUT ½-13 HEX FLG NYLOC
18..	539 108754.....	6..	SEAL, SHAFT	47..	539 990625.....	4..	NUT ½-13 HEX JAM
19..	539 131383.....	3..	HOUSING ASSY	48..	539 130653.....	3..	NUT ¾-16 FLANGE
20..	510 264201.....	1..	SPACER, IDLER BEARINGS	49..	521 996501.....	5..	NUT ¾-16 HEX FLG NYLOC
21..	525 465601.....	1..	SPACER, IDLER PIVOT	50..	539 112899....	21..	NUT 5/16-18 HEX FLG NYLOC
22..	525 310901.....	1..	SPRING, TORSION, IDLER	51..	539 109554.....	4..	WASHER ½ FLAT
23..	539 112050.....	1..	BEARING, BALL	52..	522 023401.....	1..	WASHER ¾ THICK
24..	510 263701.....	1..	BEARING, IDLER ARM	53..	539 109600.....	8..	WASHER 5/16 DISC SPRING
25..	522 729701.....	1..	BEARING, IDLER PIVOT	54..	539 990692....	10..	WASHER 5/16 STD FLT
26..	577 073401.....	4..	BEARING, IDLER STANDOFF	55..	539 106504.....	3..	WASHER, HEAVY
27..	574 262102.....	1..	BELT GUIDE, BLK	56..	539 977326.....	3..	POPPET, GREASE
28..	574 262201.....	1..	BELT KEEPER	57..	539 101474.....	3..	ZERK
29..	539 119007.....	3..	BLADE BOLT				

MOWING DECK / CUTTING DECK

52" DECK

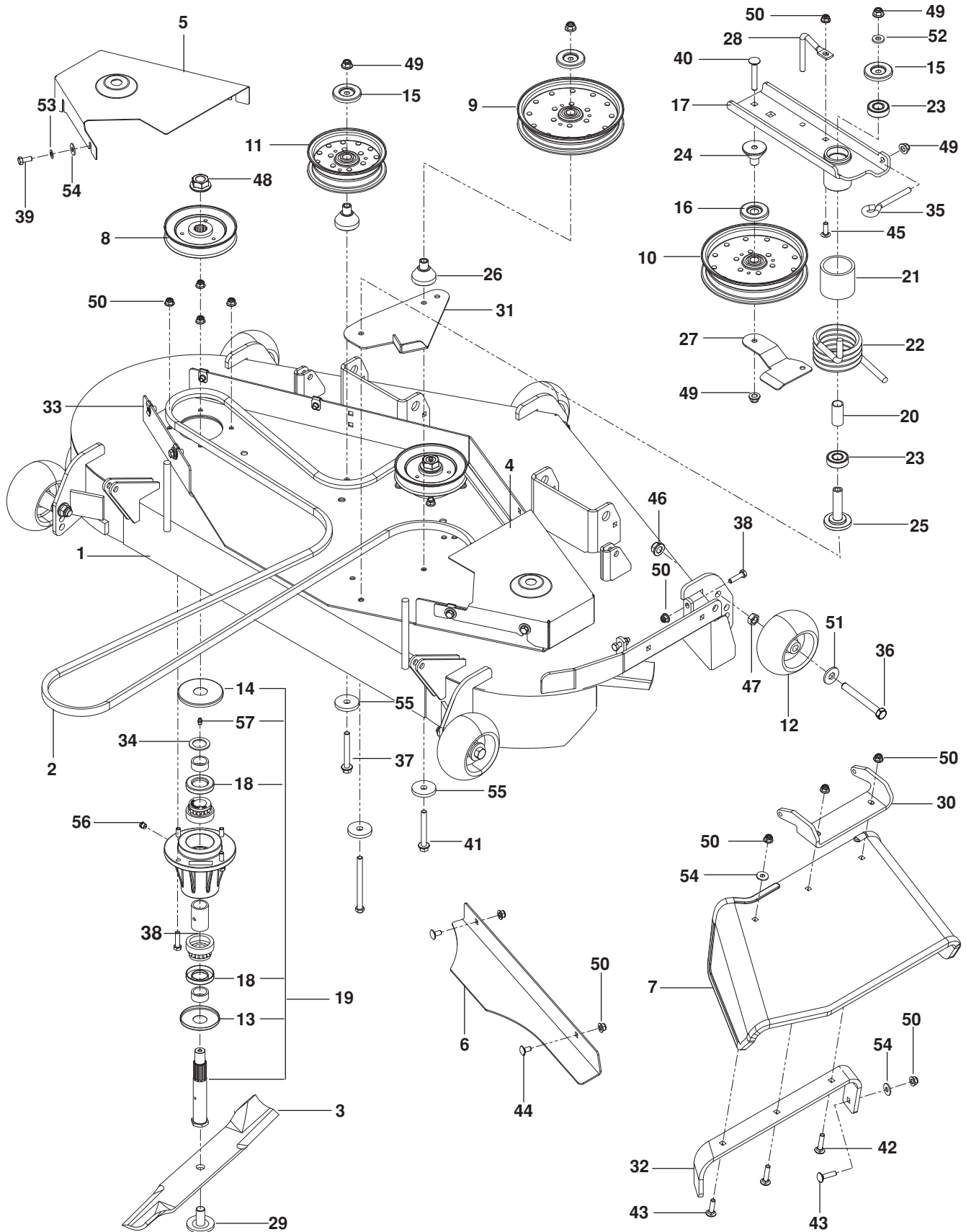

MOWING DECK / CUTTING DECK

ITEM	PART NO.	QTY.	DESCRIPTION	ITEM	PART NO.	QTY.	DESCRIPTION
1..	576 769202.....	1..	DECK w/ SFTY DECALS ORG	30..	539 130917.....	1..	BRACKET, PIVOT CHUTE
2..	576 479802.....	1..	BELT	31..	576 388702.....	1..	BRACKET, SPRING STOP BLK
3..	539 105712.....	3..	BLADE, 18"	32..	539 130920.....	1..	REINFORCEMENT, BRACKET
4..	521 969403.....	1..	BELT SHIELD, RT	33..	539 104763.....	8..	RETAINER, U TYPE
5..	521 969503.....	1..	BELT SHIELD, LT	34..	539 916561.....	3..	BUSHING 1" MACH 14 GA
6..	539 112417.....	1..	CONFINEMENT PLATE BLK	35..	574 202001.....	1..	EYE BOLT
7..	539 130901.....	1..	CHUTE, DISCHARGE	36..	539 108366.....	4..	HCS 1/2-13 x 4
8..	539 112124.....	3..	PULLEY	37..	539 101686.....	1..	HCS 3/8-16 x 4 1/2 GR 8 ZD
9..	510 015101.....	1..	PULLEY, IDLER 7"	38..	539 990627....	14..	HCS 5/16-18 x 1 1/4
10..	525 598201.....	1..	PULLEY, IDLER 7" NARROW	39..	539 976934.....	8..	HCS 5/16-18 x 3/4
11..	539 103257.....	1..	PULLEY, IDLER	40..	539 128101.....	1..	BOLT 3/8-16 x 2 1/2 CARRIAGE
12..	539 107610.....	5..	WHEEL	41..	577 117701.....	2..	HHFS 3/8-16 x 3
13..	539 108449.....	3..	DUST CAP, BOTTOM	42..	539 102933.....	2..	RHSNB 5/16-18 x 1 1/2
14..	539 108450.....	3..	DUST CAP, TOP	43..	539 100472.....	2..	RHSNB 5/16-18 x 1 1/4
15..	510 254501.....	3..	SHIELD, DUST	44..	539 990799.....	2..	RHSNB 5/16-18 x 5/8
16..	510 262201.....	1..	SHIELD, DUST	45..	539 107271.....	1..	RHSNB 5/16-18 x 1
17..	525 464402.....	1..	ARM, IDLER BLK	46..	521 991101.....	5..	NUT 1/2-13 HEX FLG NYLOC
18..	539 108754.....	6..	SEAL, SHAFT	47..	539 990625.....	5..	NUT 1/2-13 HEX JAM
19..	539 131383.....	3..	HOUSING ASSY	48..	539 130653.....	3..	NUT 3/4-16 FLANGE
20..	510 264201.....	1..	SPACER, IDLER BEARINGS	49..	521 996501.....	5..	NUT 3/8-16 HEX FLG NYLOC
21..	525 465601.....	1..	SPACER, IDLER PIVOT	50..	539 112899....	21..	NUT 5/16-18 HEX FLG NYLOC
22..	525 310901.....	1..	SPRING, TORSION, IDLER	51..	539 109554.....	5..	WASHER 1/2 FLAT
23..	539 112050.....	1..	BEARING, BALL	52..	522 023401.....	1..	WASHER 3/8 THICK
24..	510 263701.....	1..	BEARING, IDLER ARM	53..	539 109600.....	8..	WASHER 5/16 DISC SPRING
25..	522 729701.....	1..	BEARING, IDLER PIVOT	54..	539 990692....	10..	WASHER 5/16 STD FLT
26..	577 073401.....	4..	BEARING, IDLER STANDOFF	55..	539 106504.....	3..	WASHER, HEAVY
27..	574 262102.....	1..	BELT GUIDE, BLK	56..	539 977326.....	3..	POPPET, GREASE
28..	574 262201.....	1..	BELT KEEPER	57..	539 101474.....	3..	ZERK
29..	539 119007.....	3..	BLADE BOLT				

MOWING DECK / CUTTING DECK

61" DECK

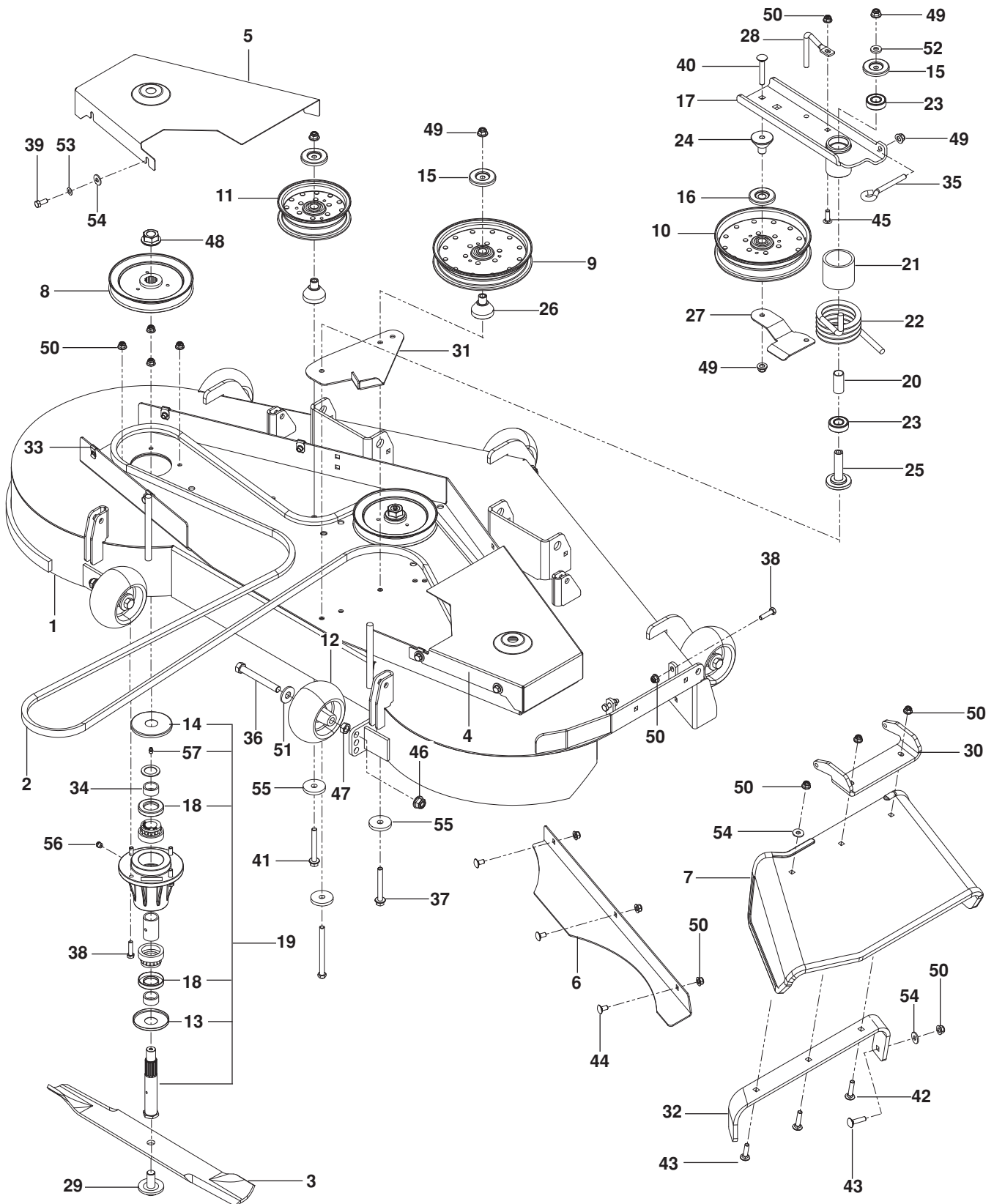

MOWING DECK / CUTTING DECK

ITEM	PART NO.	QTY.	DESCRIPTION	ITEM	PART NO.	QTY.	DESCRIPTION
1..	576 769203.....	1..	DECK w/ SFTY DECALS ORG	30..	539 130917.....	1..	BRACKET, PIVOT CHUTE
2..	576 479803.....	1..	BELT	31..	576 388702.....	1..	BRACKET, SPRING STOP BLK
3..	539 105711.....	3..	BLADE, 21"	32..	539 130920.....	1..	REINFORCEMENT, BRACKET
4..	521 970103.....	1..	BELT SHIELD, RT	33..	539 104763.....	8..	RETAINER, U TYPE
5..	521 970203.....	1..	BELT SHIELD, LT	34..	539 916561.....	3..	BUSHING 1" MACH 14 GA
6..	539 113317.....	1..	CONFINEMENT PLATE BLK	35..	574 202001.....	1..	EYE BOLT
7..	539 130901.....	1..	CHUTE, DISCHARGE	36..	539 108366.....	4..	HCS 1/2-13 x 4
8..	539 112125.....	3..	PULLEY	37..	539 101686.....	1..	HCS 3/8-16 x 4 1/2 GR 8 ZD
9..	510 015101.....	1..	PULLEY, IDLER 7"	38..	539 990627....	14..	HCS 5/16-18 x 1 1/4
10..	525 598201.....	1..	PULLEY, IDLER 7" NARROW	39..	539 976934.....	8..	HCS 5/16-18 x 3/4
11..	539 103257.....	1..	PULLEY, IDLER	40..	539 128101.....	1..	BOLT 3/8-16 x 2 1/2 CARRIAGE
12..	539 107610.....	5..	WHEEL, GAUGE	41..	577 117701.....	2..	HHFS 3/8-16 x 3
13..	539 108449.....	3..	DUST CAP, BOTTOM	42..	539 102933.....	2..	RHSNB 5/16-18 x 1 1/2
14..	539 108450.....	3..	DUST CAP, TOP	43..	539 100472.....	2..	RHSNB 5/16-18 x 1 1/4
15..	510 254501.....	3..	SHIELD, DUST	44..	539 990799.....	3..	RHSNB 5/16-18 x 5/8
16..	510 262201.....	1..	SHIELD, DUST	45..	539 107271.....	1..	RHSNB 5/16-18 x 1
17..	525 464402.....	1..	ARM, IDLER BLK	46..	521 991101.....	5..	NUT 1/2-13 HEX FLG NYLOC
18..	539 108754.....	6..	SEAL, SHAFT	47..	539 990625.....	5..	NUT 1/2-13 HEX JAM
19..	539 131383.....	3..	HOUSING ASSY	48..	539 130653.....	3..	NUT 3/4-16 FLANGE
20..	510 264201.....	1..	SPACER, IDLER BEARINGS	49..	521 996501.....	5..	NUT 3/8-16 HEX FLG NYLOC
21..	525 465601.....	1..	SPACER, IDLER PIVOT	50..	539 112899....	22..	NUT 5/16-18 HEX FLG NYLOC
22..	525 310901.....	1..	SPRING, TORSION, IDLER	51..	539 109554.....	5..	WASHER 1/2 FLAT
23..	539 112050.....	1..	BEARING, BALL	52..	522 023401.....	1..	WASHER 3/8 THICK
24..	510 263701.....	1..	BEARING, IDLER ARM	53..	539 109600.....	8..	WASHER 5/16 DISC SPRING
25..	522 729701.....	1..	BEARING, IDLER PIVOT	54..	539 990692....	10..	WASHER 5/16 STD FLT
26..	577 073401.....	4..	BEARING, IDLER STANDOFF	55..	539 106504.....	3..	WASHER, HEAVY
27..	574 262102.....	1..	BELT GUIDE, BLK	56..	539 977326.....	3..	POPPET, GREASE
28..	574 262201.....	1..	BELT KEEPER	57..	539 101474.....	3..	ZERK
29..	539 119007.....	3..	BLADE BOLT				

SEAT

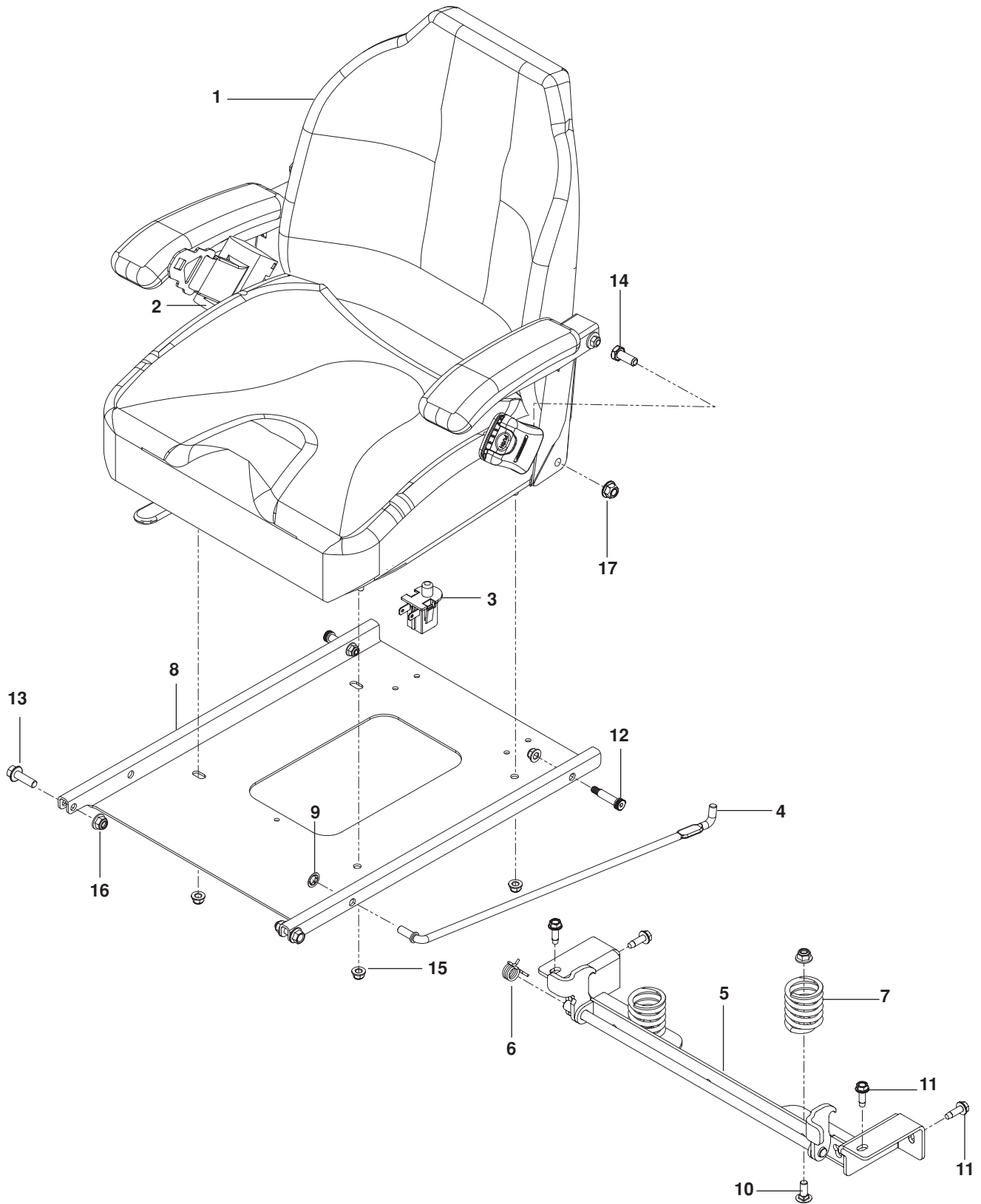

SEAT

ITEM	PART NO.	QTY.	DESCRIPTION	ITEM	PART NO.	QTY.	DESCRIPTION
1..	576 702001.....	1..	SEAT ASSY	10..	539 990645.....	2..	RHSNB $\frac{3}{8}$ -16 x 1
2..	576 783401.....	1..	SEAT BELT ASSY	11..	539 113226.....	4..	BOLT $\frac{5}{16}$ -18 x 1 THD FRM
3..	539 119741.....	1..	SWITCH, SEAT	12..	515 990601.....	2..	BOLT $\frac{3}{8}$ x $1\frac{1}{4}$ $\frac{5}{16}$ -18 SHLDR
4..	510 064101.....	1..	ROD, SEAT	13..	525 834201.....	2..	HHFS $\frac{3}{8}$ -16 x $1\frac{1}{4}$
5..	574 182202.....	1..	LATCH, SEAT	14..	539 100143.....	2..	HCS $\frac{7}{16}$ -14 x 1
6..	520 283101.....	1..	SPRING, TORSION	15..	539 112899.....	6..	NUT $\frac{5}{16}$ -18 HEX FLG NYLOC
7..	539 110300.....	2..	SPRING, SEAT	16..	521 996501.....	2..	NUT $\frac{3}{8}$ -16 HEX FLG NYLOC
8..	510 039302.....	1..	PAN, SEAT	17..	539 132019.....	2..	NUT $\frac{7}{16}$ -14 WHZ LK
9..	539 913847.....	2..	RETAINER $\frac{3}{8}$ NUT				

DECALS

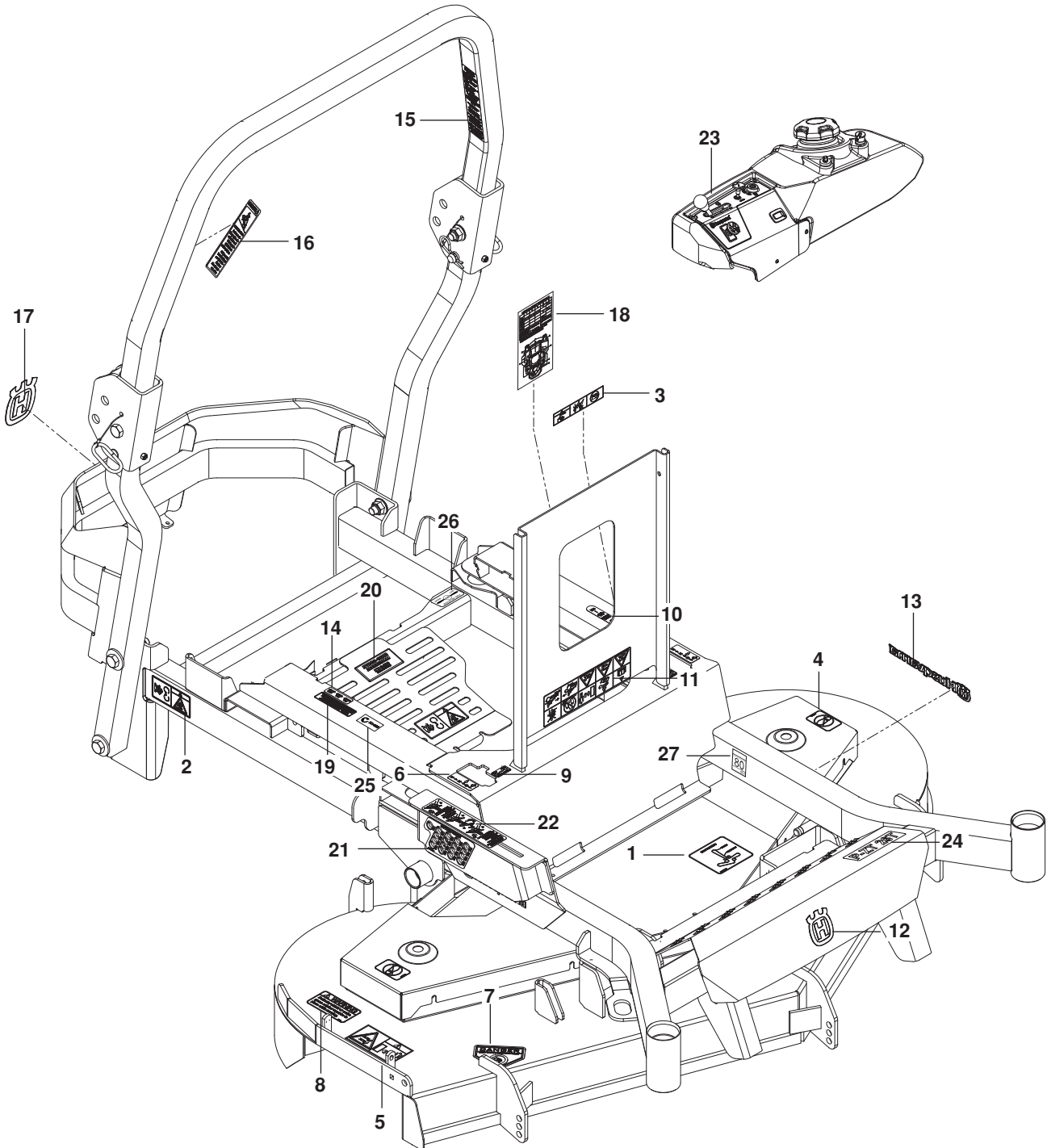

DECALS

ITEM	PART NO.	QTY.	DESCRIPTION	ITEM	PART NO.	QTY.	DESCRIPTION
1..	574 437301.....	1..	DECAL, BELT ROUTING	15..	574 569006.....	1..	DECAL, ROPS
2..	539 105744.....	1..	DECAL, BELT DRIVE WARN	16..	574 569002.....	1..	DECAL, ROPS WARNING
3..	539 105745.....	1..	DECAL, BATTERY WARNING	17..	574 455001.....	1..	DECAL, CROWN LG
4..	539 105743.....	2..	DECAL, NO STEP	18..	574 825901.....	1..	DECAL, SERVICE
5..	539 105746.....	1..	DECAL, SEVERING	19..	532 424102.....	1..	DECAL, SPARK ARRESTOR
6..	539 103333.....	2..	DECAL, MOTION CONTROL	20..	574 815501.....	1..	DECAL, ZT-3400
7..	539 913010.....	1..	DECAL, BLADE WARNING	21..	576 755301.....	1..	DECAL, HEIGHT
8..	539 113224.....	1..	DECAL, DEFLECTOR WARN	22..	576 763801.....	1..	DECAL, RELEASE LEVER
9..	539 110974.....	2..	DECAL, TRACKING	23..	510 246602.....	1..	DECAL, CONTROL
10..	539 120006.....	1..	DECAL, PARK BRAKE	24..	577 421101.....	1..	DECAL, P-ZT26
11..	539 107959.....	1..	DECAL, WARNING	25..	539 110279.....	1..	DECAL, ECM
12..	532 428676.....	1..	DECAL, CROWN SM	26..	577 150101.....	1..	DECAL, FUEL
13..	532 429196.....	2..	DECAL, HUSQVARNA	27..	532 124433.....	1..	DECAL, DB80
14..	574 569401.....	1..	DECAL, FUSE				

PROTECTION FRAME

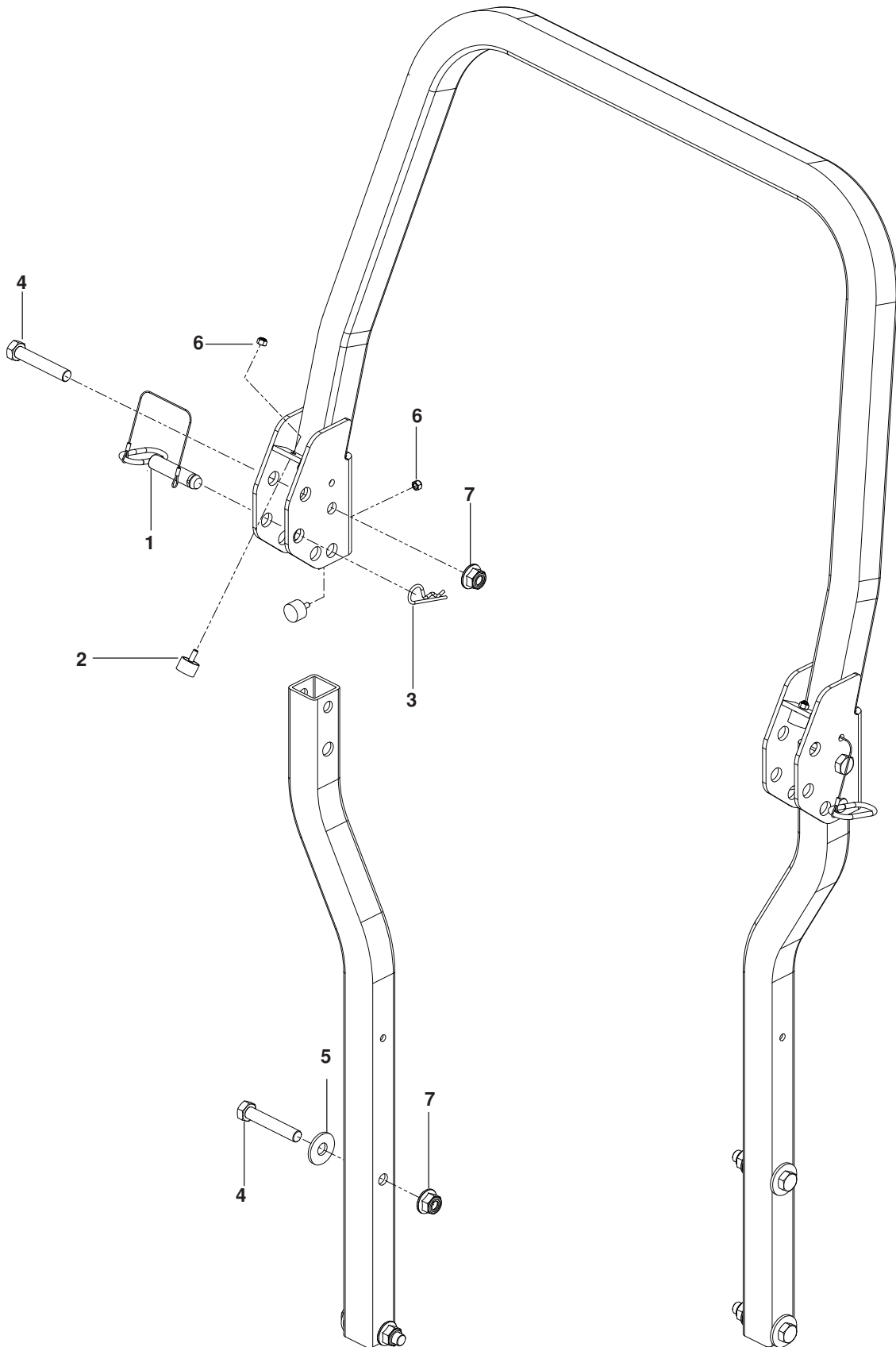

PROTECTION FRAME

ITEM	PART NO.	QTY.	DESCRIPTION	ITEM	PART NO.	QTY.	DESCRIPTION
1..	574 388001.....	2..	LATCH PIN w/ LANYARD	5..	539 102653.....	4..	WASHER ⁵ / ₈ STD FLAT
2..	522 801401.....	4..	BUMPER, MALE STUD 1/4-20	6..	539 976978.....	4..	NUT 1/4-20 HEX NYLOC
3..	539 200715.....	2..	PIN, HAIR	7..	525 829101.....	6..	NUT ⁵ / ₈ -11 FLG NYLOC
4..	539 115576.....	6..	HCS ⁵ / ₈ -11 x 3 1/2				

ACCESSORIES

BLOWER

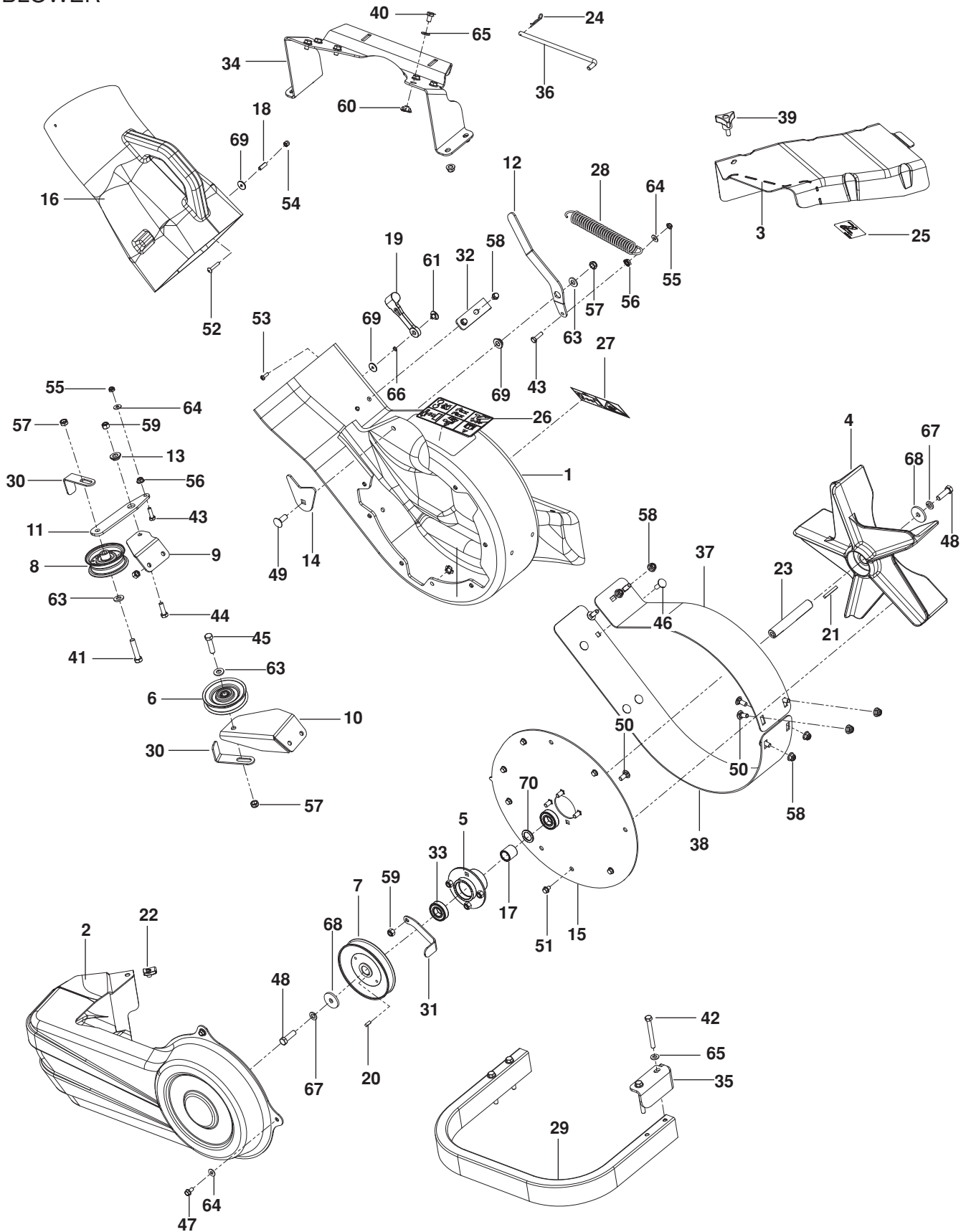

ACCESSORIES

ITEM	PART NO.	QTY.	DESCRIPTION	ITEM	PART NO.	QTY.	DESCRIPTION
1..	539 130344.....	1..	HOUSING w/DECALS	36..	522 909801.....	1..	PIN, RETENTION
2..	539 130293.....	1..	COVER, BELT	37..	525 618302.....	1..	SAND LINER, TOP
3..	539 130309.....	1..	COVER, BELT	38..	522 909702.....	1..	SAND LINER, BOTTOM
4..	539 130292.....	1..	IMPELLER	39..	539 104411.....	1..	KNOB w/ STUD
5..	539 130295.....	1..	HUB	40..	539 130315.....	6..	HCS $\frac{5}{16}$ -18 x $\frac{1}{2}$
6..	539 113683.....	1..	PULLEY, V-IDLER	41..	539 976949.....	1..	HCS $\frac{3}{8}$ -16 x $1\frac{3}{4}$
7..	539 130324.....	1..	PULLEY	42..	539 101721.....	4..	HCS $\frac{5}{16}$ -18 x $2\frac{3}{4}$
8..	539 919078.....	1..	PULLEY, IDLER	43..	539 990643.....	2..	HCS $\frac{1}{4}$ -20 x $\frac{7}{8}$
9..	539 130335.....	1..	MOUNT, IDLER UPPER	44..	539 990209.....	1..	HCS $\frac{5}{16}$ -18 x 1
10..	539 130336.....	1..	MOUNT, IDLER LOWER	45..	539 990655.....	1..	HCS $\frac{3}{8}$ -16 x $1\frac{1}{2}$
11..	539 130337.....	1..	ARM, IDLER	46..	539 990208.....	6..	RHSNB $\frac{5}{16}$ -18 x 1
12..	539 130338.....	1..	ARM, TENSION	47..	539 108461.....	3..	BOLT $\frac{1}{4}$ -20 x $\frac{1}{2}$ HWST
13..	539 130301.....	2..	BUSHING	48..	539 110321.....	2..	BOLT $\frac{3}{8}$ -24 x $1\frac{1}{4}$ HEX GR 8
14..	539 132124.....	1..	PLATE, BACKING	49..	539 990645.....	1..	RHSNB $\frac{3}{8}$ -16 x 1
15..	539 130341.....	1..	PLATE, OUTER	50..	539 990316.....	6..	RHSNB $\frac{5}{16}$ -18 x $\frac{3}{4}$
16..	522 909301.....	1..	CHUTE, MIDDLE	51..	539 990302.....	8..	SCREW $\frac{1}{4}$ -20 x $\frac{3}{8}$ THD FRM
17..	539 130323.....	1..	SPACER	52..	539 108083.....	1..	SCREW #10- 24 x $1\frac{1}{8}$
18..	539 108085.....	1..	SPACER, SPLIT	53..	539 976952.....	1..	SCREW #10-24 x .625 MACH
19..	539 108088.....	1..	LATCH, HOOD	54..	539 108086.....	1..	NUT #10- 24 ACORN
20..	539 115667.....	1..	KEY $\frac{3}{16}$ x $\frac{1}{2}$	55..	539 108120.....	2..	NUT $\frac{1}{4}$ -20 HEX THIN NYLOC
21..	539 125229.....	1..	KEY $1\frac{1}{2}$	56..	539 108735.....	2..	NUT $\frac{1}{4}$ -20 HEX FLANGE LK
22..	539 104763.....	1..	RETAINER, U TYPE	57..	539 200282.....	3..	NUT $\frac{3}{8}$ -16 HEX JAM NYLOC
23..	539 130316.....	1..	SHAFT, IMPELLER	58..	539 112899.....	10..	NUT $\frac{5}{16}$ -18 HEX FLG NYLOC
24..	539 976988.....	1..	HAIRPIN COTTER	59..	539 990717.....	9..	NUT $\frac{5}{16}$ -18 HEX NYLOC
25..	539 130349.....	1..	DECAL, BELT ROUTING	60..	539 130313.....	6..	NUT $\frac{5}{16}$ -18 TEE
26..	539 105785.....	1..	DECAL, WARNING	61..	539 108089.....	1..	NUT, PLATED
27..	539 106741.....	1..	DECAL, SEVERING	62..	539 130314.....	11..	NUT $\frac{1}{4}$ -20 TEE
28..	539 101977.....	1..	SPRING, TRACTION	63..	539 990122.....	3..	WASHER $\frac{3}{8}$ SAE FLT
29..	522 909402.....	1..	TUBE, RUB	64..	539 990055.....	5..	WASHER $\frac{1}{4}$ FLAT SAE
30..	539 131087.....	2..	KEEPER, BELT REAR	65..	539 990188.....	10..	WASHER $\frac{5}{16}$ SAE FLAT
31..	539 131085.....	1..	KEEPER, BELT, OUTER	66..	539 109552.....	1..	WASHER $\frac{3}{16}$ SLW
32..	539 130346.....	1..	KEEPER	67..	539 990118.....	2..	WASHER $\frac{3}{8}$ SLW
33..	539 130296.....	2..	BEARING	68..	539 110323.....	2..	WASHER, HARDENED
34..	522 909602.....	1..	BRACKET, MOUNT	69..	539 108084.....	2..	WASHER $\frac{3}{16}$ x $\frac{3}{4}$ x 16 GA
35..	522 909502.....	1..	BRACKET, RETENTION	70..	539 910935.....	1..	WASHER $\frac{3}{4}$ FLAT

ACCESSORIES

HOOD AND MOUNTS

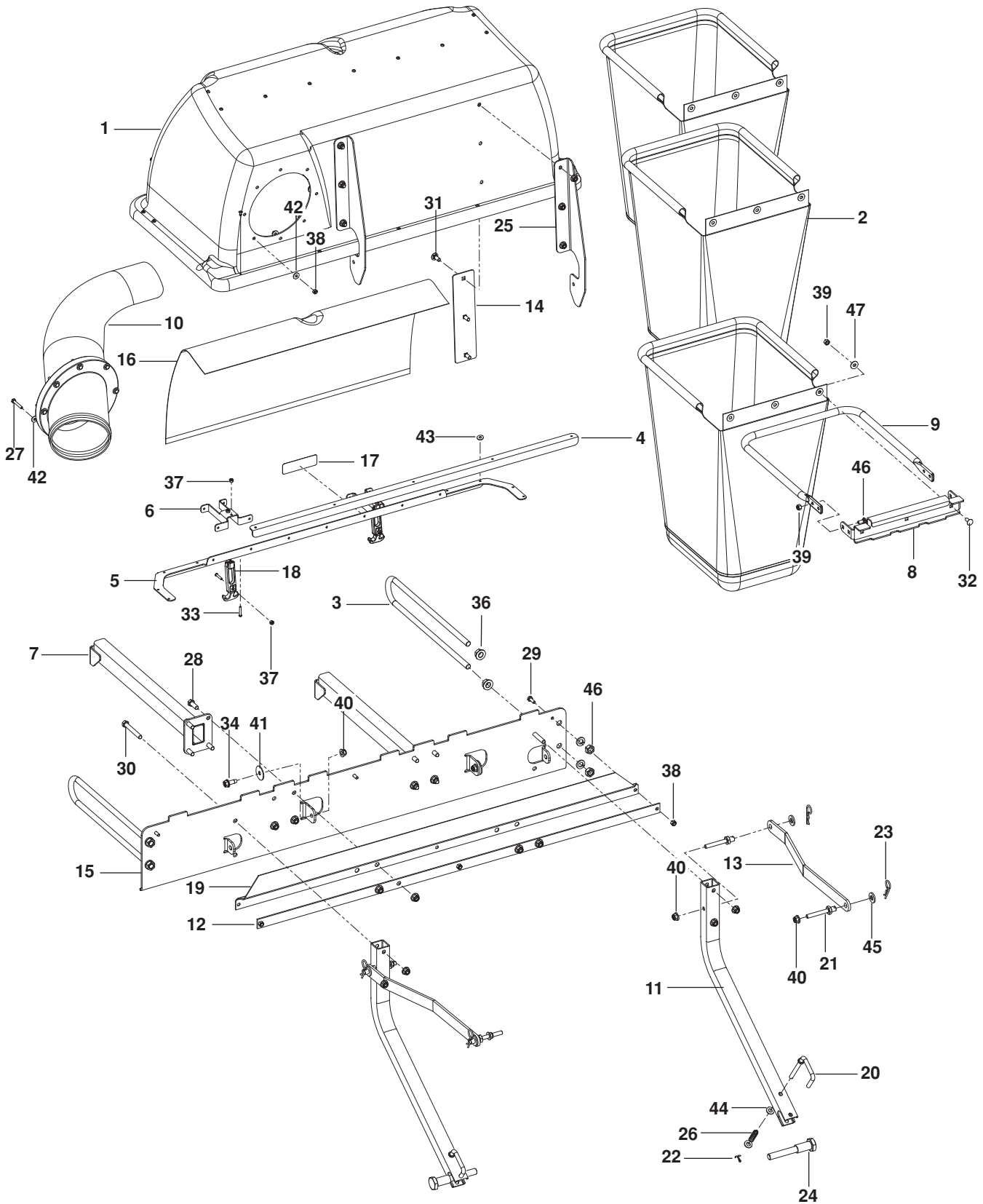

ACCESSORIES

ITEM	PART NO.	QTY.	DESCRIPTION	ITEM	PART NO.	QTY.	DESCRIPTION
1..	539 111172.....	1..	HOOD	25..	525 445402.....	2..	BRACKET, HINGE
2..	539 111300.....	3..	BAG, SMALL	26..	525 816001.....	2..	SPRING, COMPRESSION
3..	539 111158.....	2..	SUPPORT, OUTER	27..	539 991003.....	8..	HCS 1/4-20 x 1 3/4
4..	575 486802.....	1..	SUPPORT, HOOD REAR	28..	539 990563.....	8..	HCS 3/8-16 x 1
5..	539 111174.....	1..	SUPPORT, HOOD	29..	539 990580.....	3..	HCS 1/4-20 x 3/4
6..	539 111175.....	2..	SUPPORT, DRAW LATCH	30..	539 990629.....	4..	HCS 3/8-16 x 2 1/4
7..	539 111162.....	2..	ARM, SUPPORT	31..	539 990645.....	6..	RHSNB 3/8-16 x 1
8..	575 467702.....	3..	HANGER, BAG	32..	539 990316....	21..	RHSNB 5/16-18 x 3/4
9..	539 111166.....	3..	TUBE, BAG FRAME	33..	539 111186.....	6..	SCREW #10-24 x 1 1/8 MACH
10..	539 111182.....	1..	TUBE, INLET	34..	539 107476.....	2..	BOLT 3/8-16 x 1 THD FRM
11..	525 444502.....	2..	TUBE, HITCH	35..	539 990625.....	4..	NUT 1/2-13 HEX JAM
12..	539 111171.....	1..	STRAP, SEAL	36..	539 111187.....	4..	NUT 1/2-13 HEX WHIZLK
13..	525 444902.....	2..	STRAP	37..	539 976977.....	6..	NUT #10-24 HEX NYLOC
14..	539 111181.....	2..	PLATE, HOOD MOUNT	38..	539 976978....	11..	NUT 1/4-20 HEX NYLOC
15..	525 444702.....	1..	PLATE, HITCH MOUNT	39..	539 990717....	21..	NUT 5/16-18 NYLOC
16..	539 111183.....	1..	MESH, POLY DIAMOND	40..	521 996501....	24..	NUT 3/8-16 HEX FLG NYLOC
17..	539 111260.....	1..	DECAL, VENTILATION	41..	539 102998.....	2..	WASHER, FRICTION
18..	539 200478.....	2..	LATCH, DRAW	42..	539 990598....	16..	WASHER 1/4 FLAT
19..	539 111167.....	1..	SEAL, RUBBER	43..	539 110033.....	8..	WASHER #10 MACH SCR
20..	525 815901.....	2..	PIN, RETENTION	44..	539 990122.....	4..	WASHER 3/8 SAE FLT
21..	525 445001.....	4..	PIN, MOUNT	45..	539 990250.....	4..	WASHER
22..	539 990365.....	2..	PIN, COTTER 1/8 x 3/4	46..	539 990254.....	4..	WASHER 1/2 SLW
23..	539 976989.....	5..	HAIRPIN	47..	539 990692.....	9..	WASHER 5/16 FLAT
24..	525 445301.....	2..	BOLT, PIVOT				

ACCESSORIES

GUARDS AND WEIGHTS

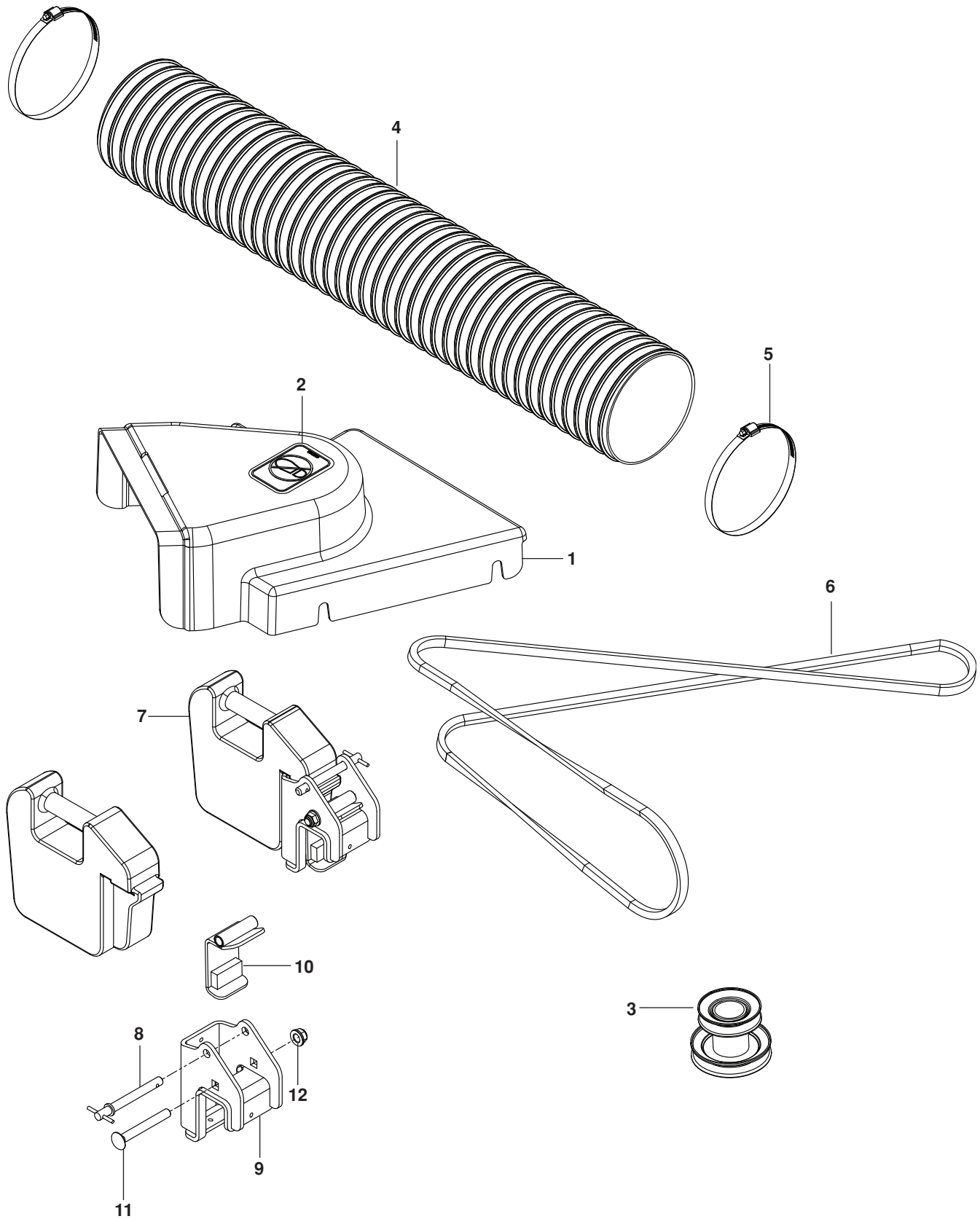

ACCESSORIES

ITEM	PART NO.	QTY.	DESCRIPTION
1..	539 130306.....	1..	SHIELD, LOWER 48
	539 130307.....	1..	SHIELD, LOWER, 52
	539 130308.....	1..	SHIELD, LOWER, 61
2..	539 105743.....	1..	DECAL, NO STEP
3..	576 747001.....	1..	STACK PULLEY, 48
	522 909901.....	1..	STACK PULLEY, 52
	522 910001.....	1..	STACK PULLEY, 61
4..	523 000201.....	2..	HOSE
5..	539 109901.....	2..	CLAMP, HOSE

ITEM	PART NO.	QTY.	DESCRIPTION
6..	539 130347.....	1..	DRIVE BELT 48, 52
	522 130348.....	1..	DRIVE BELT, 61
7..	539 092531.....	2..	WEIGHT CAST, FRONT
8..	575 509901.....	2..	PIN, DETENT
9..	575 509802.....	2..	BRACKET, WEIGHT, BLK
10..	575 509501.....	2..	LATCH
11..	539 108484.....	2..	RHSNB 1/2-13 x 4
12..	521 991101.....	2..	NUT 1/2-13 HEX FLG NYLOC

ACCESSORIES

MULCH KIT

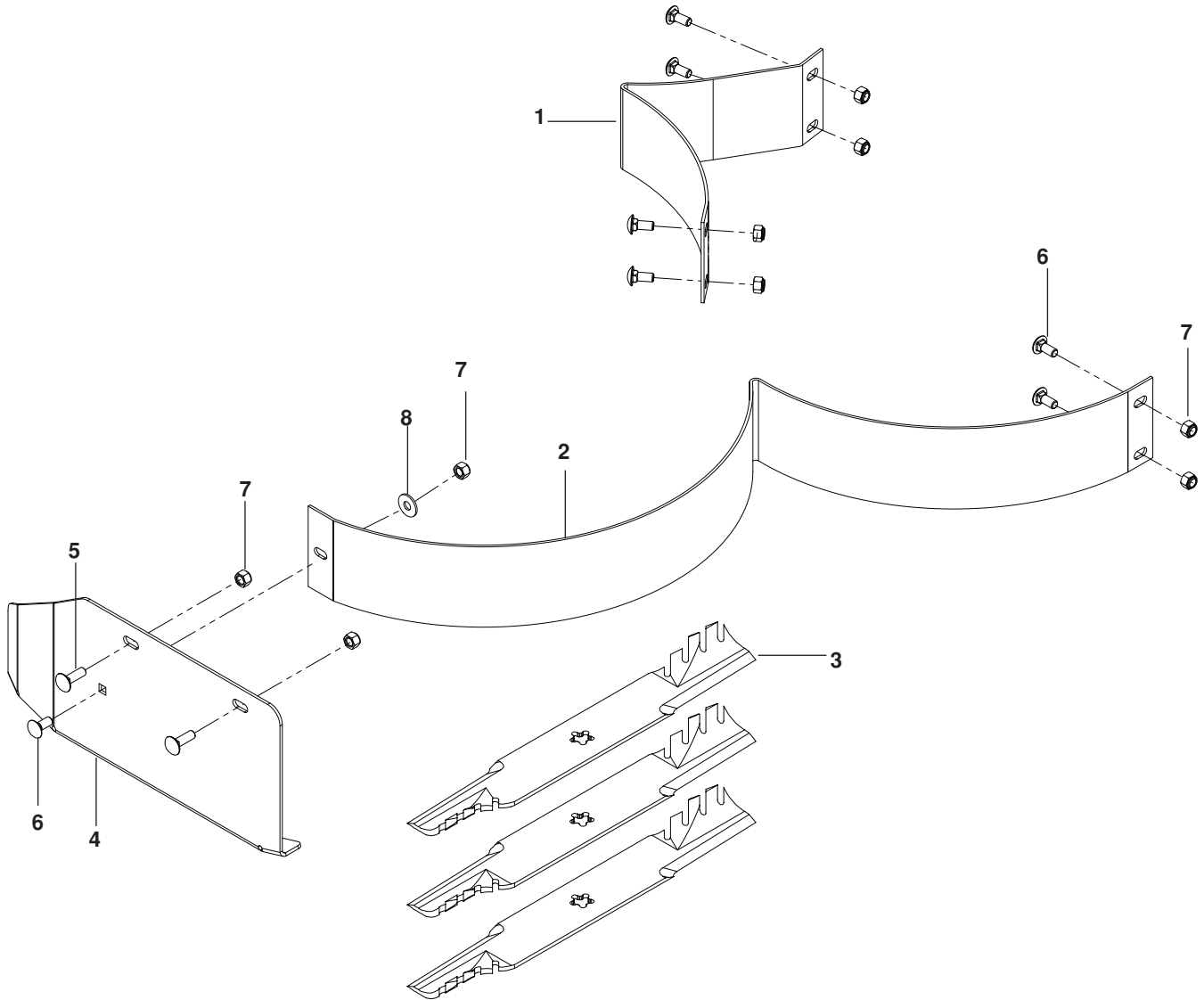

ACCESSORIES

ITEM	PART NO.	QTY.	DESCRIPTION	ITEM	PART NO.	QTY.	DESCRIPTION
1..	539 113417.....	1..	BAFFLE, MULCH 48 LT	4..	539 113428.....	1..	CAP, MULCH 48
	539 112421.....	1..	BAFFLE, MULCH 52 LT		539 112344.....	1..	CAP, MULCH, 52
	539 113313.....	1..	BAFFLE, MULCH 61, LT		539 113327.....	1..	CAP, MULCH, 61
2..	539 113419.....	1..	BAFFLE, MULCH 48 RT	5..	539 990208.....	2..	RHSNB ⁵ / ₁₆ -18 x 1
	539 112435.....	1..	BAFFLE, MULCH 52 RT	6..	539 990316.....	7..	RHSNB ⁵ / ₁₆ -18 X ³ / ₄
	539 113315.....	1..	BAFFLE, MULCH 61, RT	7..	539 990717.....	9..	NUT ⁵ / ₁₆ -18 NYLOC
3..	522 037401.....	3..	BLADE, GATOR 48	8..	539 990692.....	1..	WASHER ⁵ / ₁₆
	521 981501.....	3..	BLADE, GATOR 52				
	521 981601.....	3..	BLADE, GATOR 61				

