

REPAIR PARTS MANUAL
MODEL NO. YP18KH38 (96041031200)
LAWN TRACTOR

Yard Pro

HOW TO USE THIS MANUAL

This manual is designed to provide the customer with a means to identify the parts on his/her tractor when ordering repair parts. The illustrations may or may not represent the actual assemblies; therefore, it is not recommended to use this manual as a guide to assemble or disassemble the tractor. Some hardware and parts are drawn larger in order to more readily identify them.

Each tractor has its own model number.

The model number for your tractor can be found on the fender under the seat.

When ordering parts, always give the following information:

- Product - "Tractor"
- MODEL NUMBER - "YP18KH38 (96041031200)"
- Part Number
- Part Description

TABLE OF CONTENTS

SCHEMATIC	3
ELECTRICAL.....	4-5
CHASSIS	6-7
DRIVE.....	8-9
ENGINE.....	10-11
STEERING	12-13
MOWER DECK	14-15
MOWER LIFT.....	16
SEAT	17
DECALS.....	18
WARRANTY.....	BACK COVER

TRACTOR - - MODEL NUMBER YP18KH38 (96041031200), PRODUCT NO. 960 41 03-12 SCHEMATIC

SCH10

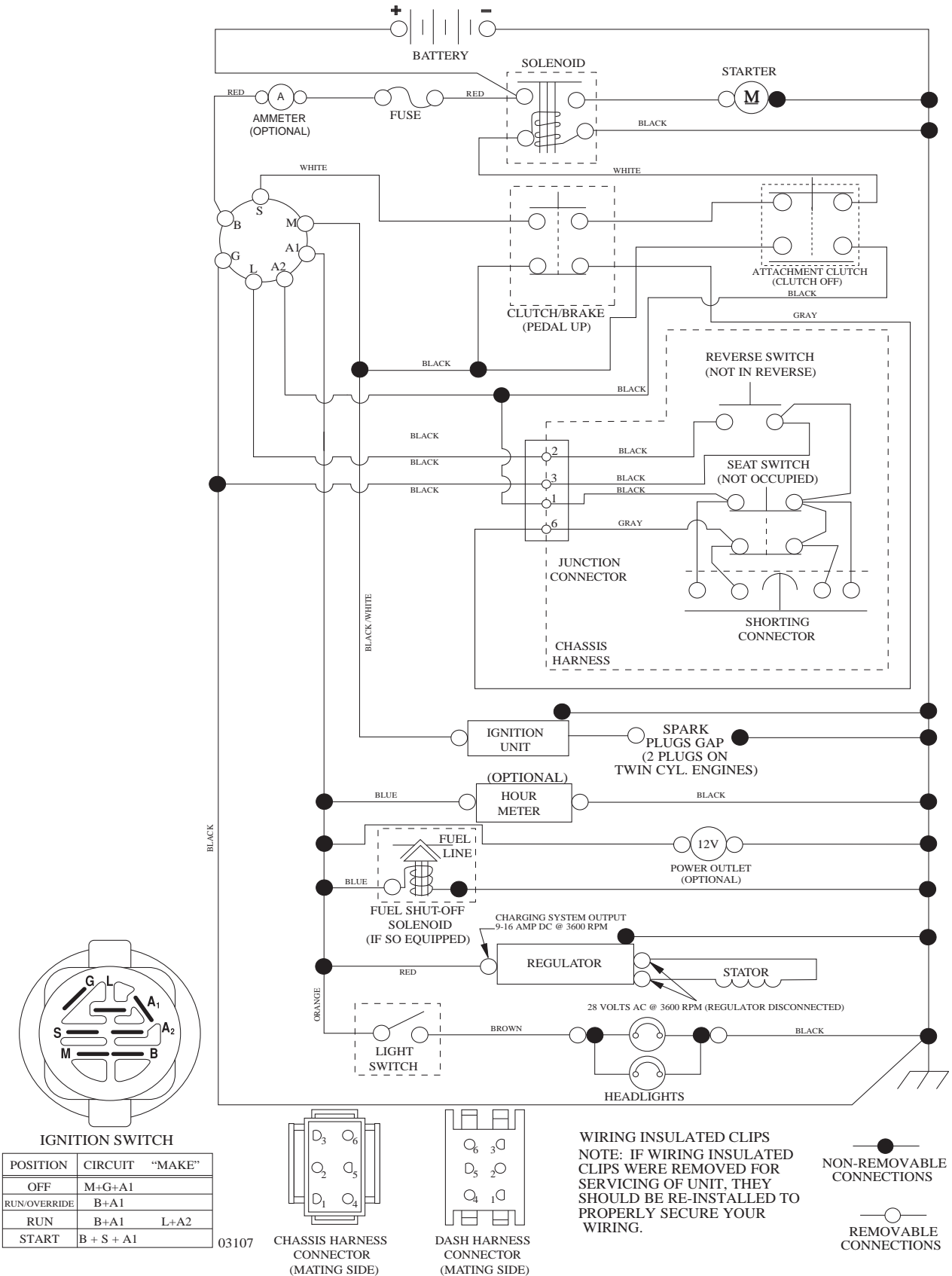

TRACTOR -- MODEL NUMBER YP18KH38 (96041031200), PRODUCT NO. 960 41 03-12
ELECTRICAL

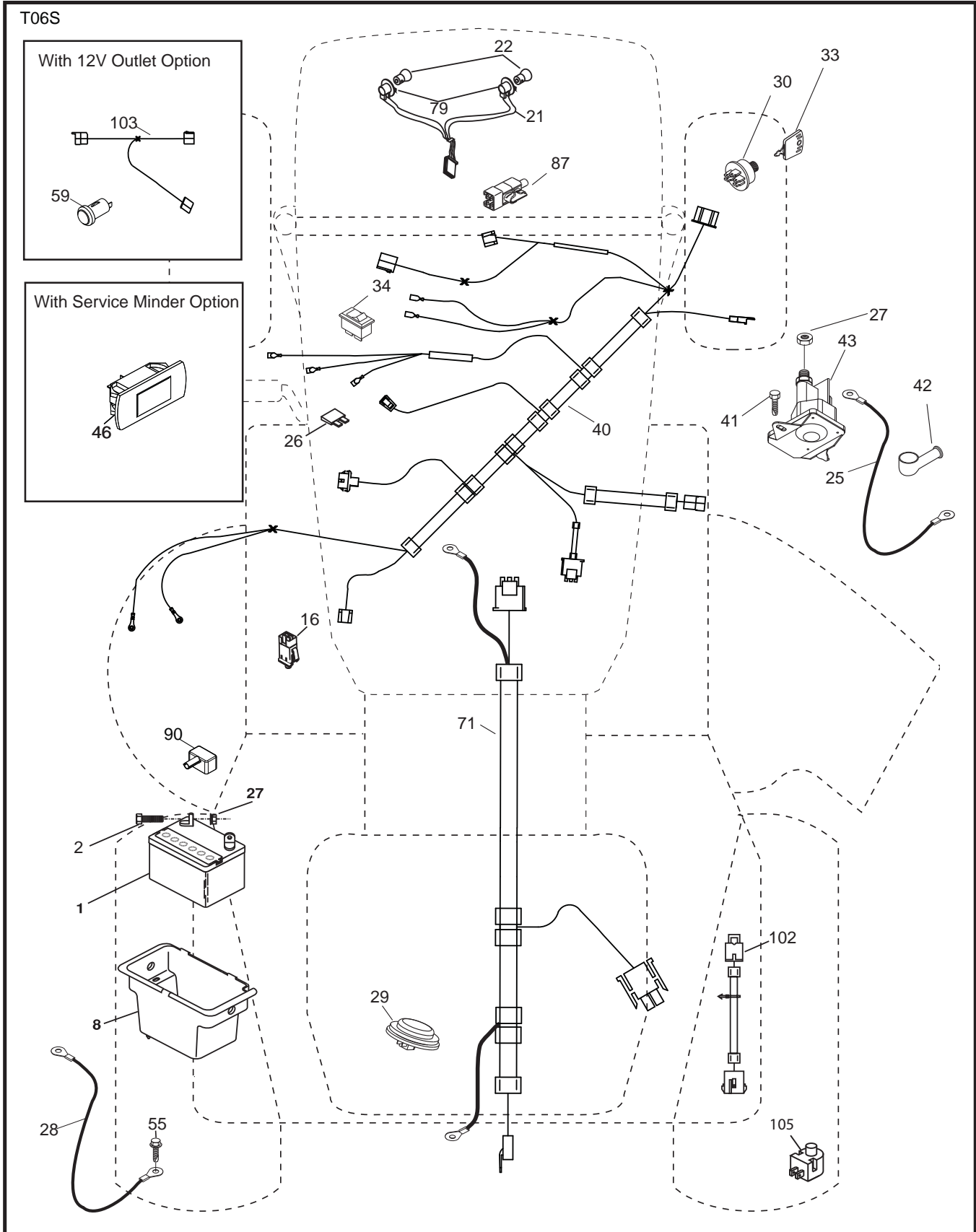

**TRACTOR - - MODEL NUMBER YP18KH38 (96041031200), PRODUCT NO. 960 41 03-12
ELECTRICAL**

KEY NO.	PART NO.	DESCRIPTION
1	532 16 34-65	Battery
2	874 76 04-12	Bolt Hex Hd 1/4-20 unc x 3/4
8	532 19 32-28	Box Battery
16	532 17 61-38	Switch Interlock
21	532 18 37-59	Harness Socket Light
22	532 00 41-52	Bulb, Light #1156
25	532 41 28-94	Cable Starter 6 Ga. BL/Red 14.5
26	532 17 51-58	Fuse
27	873 51 04-00	Nut Keps Hex 1/4-20 unc
28	532 19 88-85	Cable Ground 18" Rear Battery Blk 6 Ga.
29	532 40 15-45	Switch Seat
30	532 19 33-50	Switch Ign
33	532 41 19-33	Key/Chain
34	532 11 07-12	Switch Light/Reset
40	532 40 10-98	Harness Ign Dash
41	817 72 04-08	Screw 1/4-20 unc x 1/2
42	532 13 15-63	Cover Terminal Red
43	532 19 25-07	Solenoid
55	817 06 05-12	Screw 5/16-18 x 3/4
71	532 40 04-49	Harness Ign. Chass.
79	532 17 52-42	Socket Asm. Bulb
87	532 19 78-02	Switch Interlock Clutch
90	532 43 53-95	Cover Terminal
102	532 40 44-54	Harness Pigtail
105	532 40 75-68	Switch Reverse

NOTE: All component dimensions given in U.S. inches
1 inch = 25.4 mm

TRACTOR - - MODEL NUMBER YP18KH38 (96041031200), PRODUCT NO. 960 41 03-12
CHASSIS

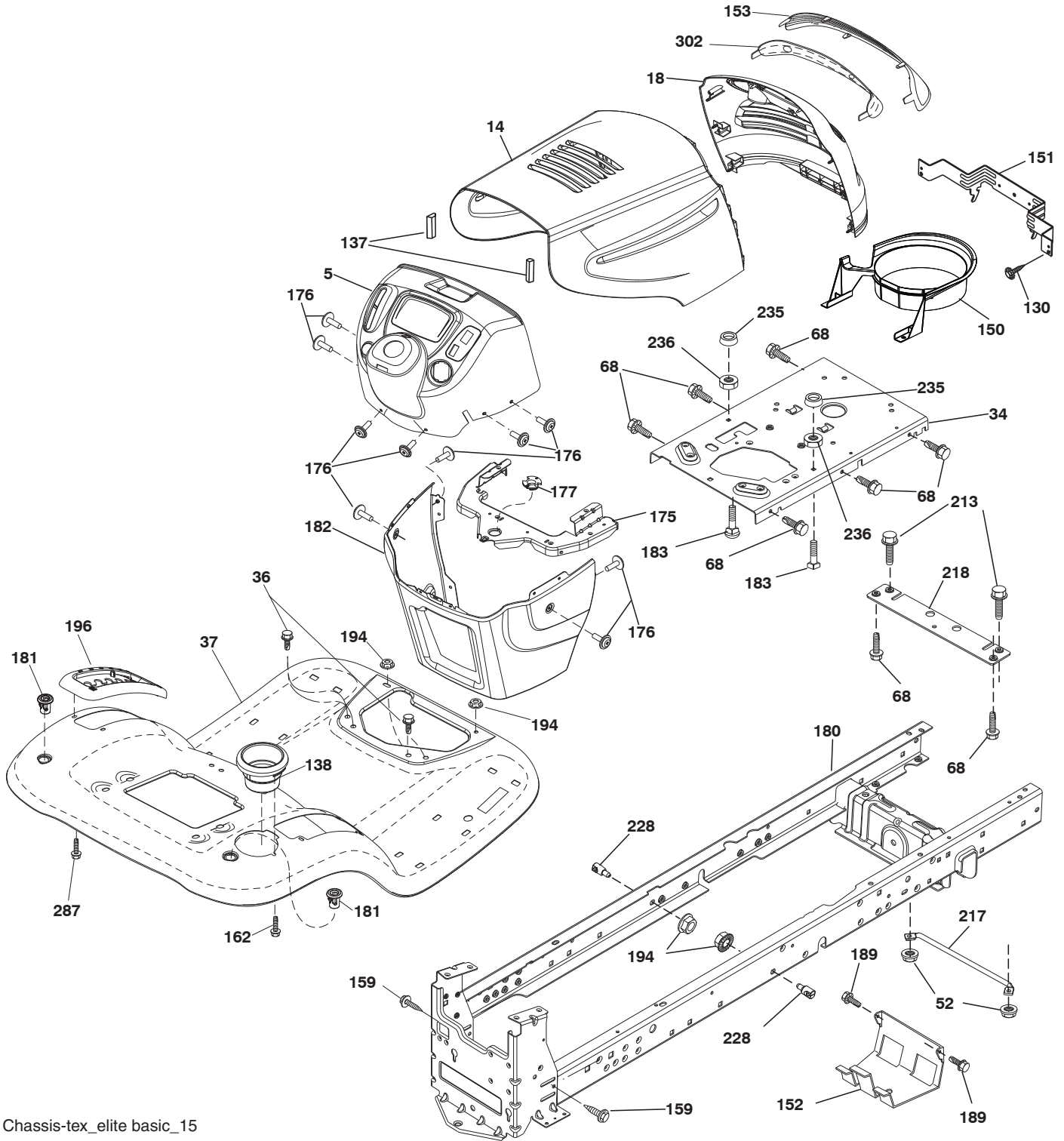

Chassis-tex_elite basic_15

**TRACTOR - - MODEL NUMBER YP18KH38 (96041031200), PRODUCT NO. 960 41 03-12
CHASSIS**

KEY NO.	PART NO.	DESCRIPTION
5	532 41 17-64	Dash
14	532 44 15-32	Hood
18	532 18 67-06	Grille
34	532 44 72-53	Plate Engine
36	817 06 05-12	Screw 5/16-18 x 3/4
37	532 44 34-76	Fender
52	873 68 05-00	Nut Lock 5/16-18
68	817 49 05-08	Screw Thdrol 5/16-18 x 1/2
130	532 41 63-58	Screw #10 x 0.750
137	532 18 49-21	Bumper Hood
138	532 40 97-30	Cupholder
150	532 18 44-62	Duct Heat Hood
151	532 40 78-07	Bracket Pivot
152	532 19 95-35	Shield Browning
153	532 18 58-46	Lens Grille
159	817 00 06-12	Screw Hexwsh Thdrol 3/8-16 x 3/4
162	532 14 24-32	Screw Hex Wsh Hi-Lo 1/4 x 1/2
175	532 19 32-43	Crossmember
176	532 40 07-76	Screw 10-24 x 5/8 Wshd Qdrx
177	532 19 52-28	Bushing Steering
180	532 19 54-57	Chassis
181	532 40 47-96	Bushing Mtg. Fender Crgo.
182	532 19 30-57	Dash Lower
183	874 52 05-20	Bolt 5/16-18 x 1-1/4
189	817 00 05-12	Screw 5/16-18 x 3/4
194	873 90 05-00	Nut Lock Hex Flange 5/16-18
196	532 41 45-79	Console Asm. Deck Lift
213	874 76 05-12	Bolt 5/16-18 x 3/4
217	532 40 91-67	Rod Pivot Hood
218	532 19 63-95	X-Piece Hood Step
228	532 19 51-61	Stud Fastener
235	532 40 61-29	Spacer Fender
236	873 93 05-00	Nut Center Lock 5/16-18
287	817 60 04-06	Screw 1/4-20 x 3/8
302	532 18 35-50	Insert Lens Reflective

NOTE: All component dimensions given in U.S. inches
1 inch = 25.4 mm

TRACTOR -- MODEL NUMBER YP18KH38 (96041031200), PRODUCT NO. 960 41 03-12
DRIVE

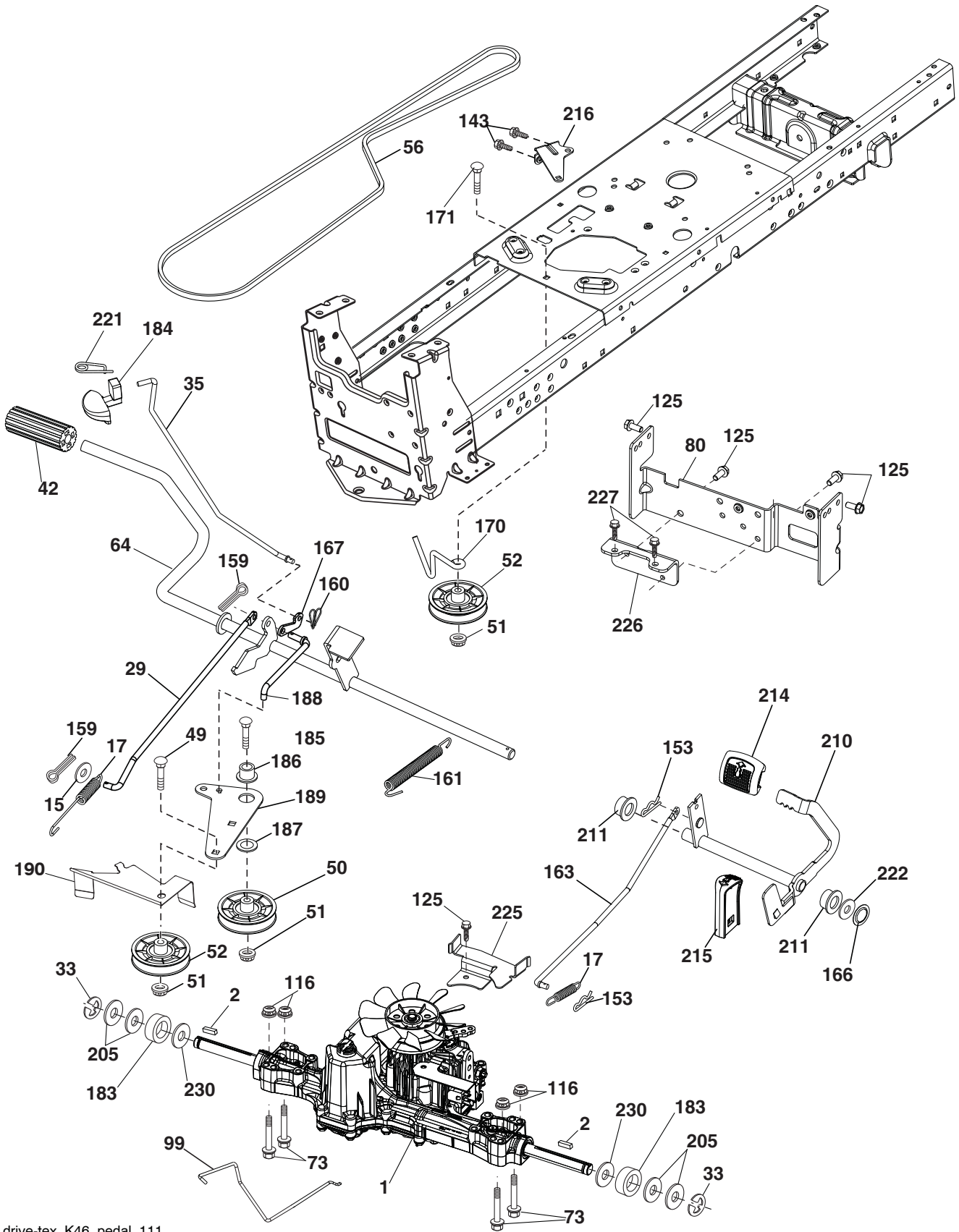

drive-tex_K46_pedal_111

**TRACTOR - - MODEL NUMBER YP18KH38 (96041031200), PRODUCT NO. 960 41 03-12
DRIVE**

KEY NO.	PART NO.	DESCRIPTION	KEY NO.	PART NO.	DESCRIPTION
1	---	Transaxle, TUFFTORQ K46 BT (426120) (Order parts from transaxle manufacturer)	167	532 40 52-57	Latch Brake Parking
2	532 12 35-83	Key	170	532 19 43-22	Keeper Belt Centerspan
15	819 13 13-16	Washer 13/32 x 13/16 x 16 Ga.	171	872 11 06-16	Bolt RDHD SQNK 3/8-16 unc x 2
17	532 41 36-78	Spring, Brake	183	532 13 70-57	Spacer Split
29	532 40 38-06	Rod, Brake	184	532 44 15-04	Handle Parking Brake
33	812 00 00-01	Ring E	185	872 11 06-22	Bolt Rdhd Sqnk 3/8-16 x 2-3/4 Gr. 5
35	532 19 77-22	Rod, Brake, Park	186	532 19 43-21	Spacer Retainer
42	532 12 48-72	Cover, Foot Pedal	187	819 13 32-10	Washer
49	872 11 06-14	Bolt	188	532 19 43-23	Link Clutch Ground Drive
50	532 19 43-27	Pulley Idler Flat	189	532 19 43-17	Bellcrank Ground Drive
51	873 90 06-00	Lock Nut 3/8-16	190	532 19 43-18	Keeper Bellcrank Ground Drive
52	532 19 43-26	Idler V-Groove 910" Offset	210	532 40 09-80	Rocker Asm. Pedal Control
56	532 13 09-69	V-Belt, Drive	211	532 12 01-83	Bearing Nylon
64	532 19 78-65	Shaft Asm. Pedal Brake Control	214	532 42 12-63	Pedal Forward Pad
73	874 49 05-40	Bolt 5/16-18 x 2-1/2 Gr. 5	215	532 40 17-23	Pedal Reverse
80	532 44 06-19	Strap Torque	216	532 19 61-31	Bracket Pulley Idler
99	532 41 57-42	Rod Asm. Bypass	221	532 40 31-87	Retainer Spring Clip Handle
116	873 90 05-00	Nut Lock Hex Flange 5/16-18	222	879 21 20-10	Washer 21/32 x 1-1/4 x 10 Ga.
125	817 00 05-12	Screw 5/16-18 x 3/4	225	532 40 33-19	Keeper Belt Trans.
143	817 49 05-08	Screw 5/16-18 x 1/2	226	532 40 15-64	Bracket Mount Torque
153	532 12 47-88	Retainer Spring	227	817 49 05-12	Screw Thd. 5/16-18 x 3/4
159	876 02 04-12	Pin Cotter 1/8 x 3/4	230	532 18 89-67	Washer Hardened
160	532 16 94-84	Retainer Clip			
161	532 10 57-09	Spring, Return, Clutch			
163	532 44 82-75	Rod Pedal Control			
166	532 42 91-64	Nut Push			

NOTE: All component dimensions given in U.S. inches
1 inch = 25.4 mm

TRACTOR - - MODEL NUMBER YP18KH38 (96041031200), PRODUCT NO. 960 41 03-12
ENGINE

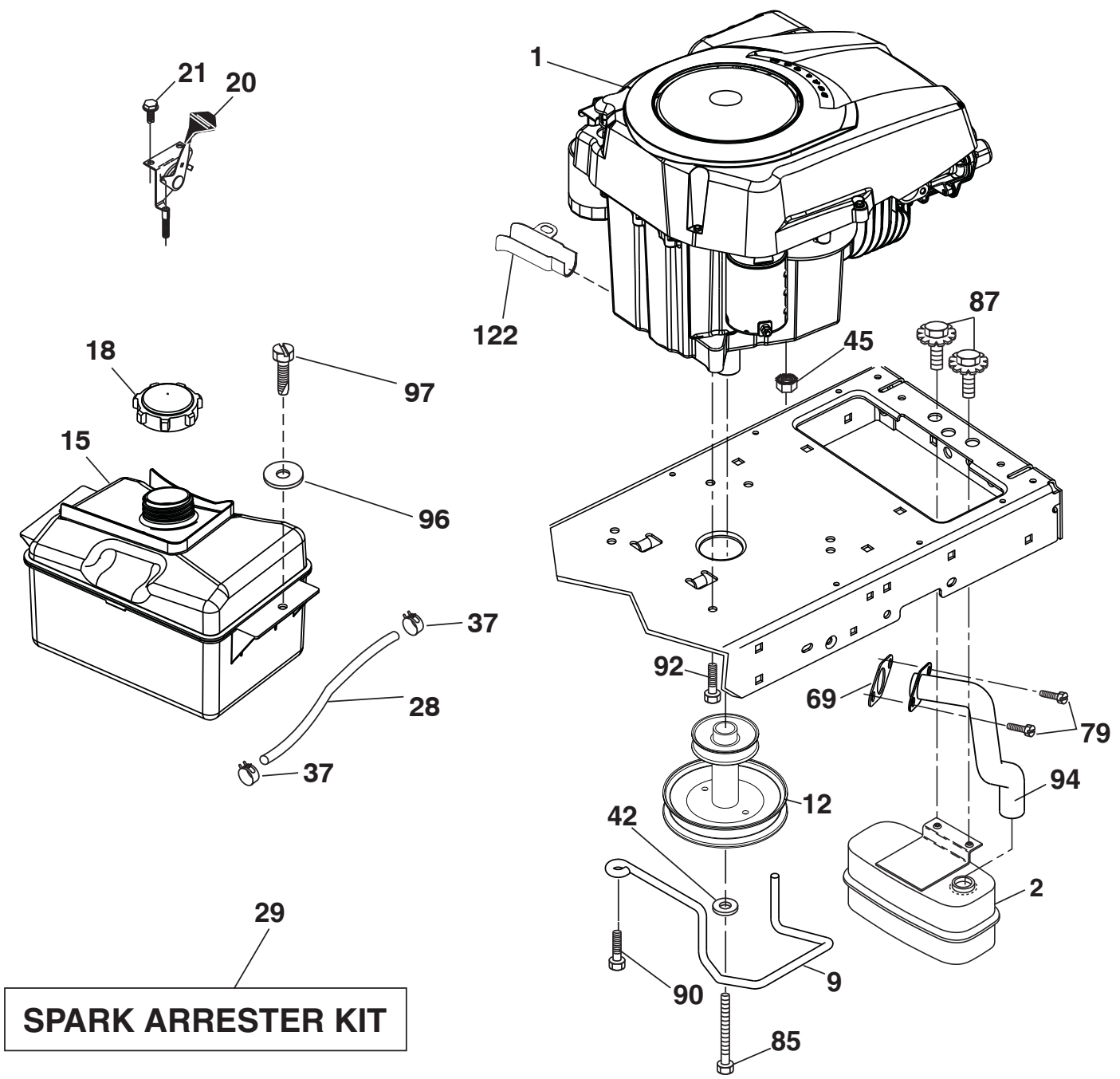

engine-tex_kohl_23_r3

**TRACTOR - - MODEL NUMBER YP18KH38 (96041031200), PRODUCT NO. 960 41 03-12
ENGINE**

KEY NO.	PART NO.	DESCRIPTION
1	-----	Engine Kohler Model No. SV540-3212 (438340)(Order parts from engine manufacturer.)
2	532 18 86-55	Muffler
9	532 19 43-20	Keeper Belt Engine
12	532 40 54-71	Pulley Engine
15	532 40 75-45	Tank Fuel
18	532 43 02-20	Cap Fuel
20	532 17 05-45	Control Throttle/Choke
21	532 41 63-58	Screw #10 x 0.750
28	532 13 70-40	Fuel Line
29	532 13 71-80	Spark Arrester Kit
37	532 12 34-87	Clamp Hose
42	810 04 07-00	Washer Lock 7/16
45	873 51 04-00	Nut Keps Hex 1/4-20 unc
69	532 18 59-09	Gasket
79	532 19 23-34	Screw Socket Hd 5/16-18 x .75
85	532 17 39-37	Bolt Hex 7/16-20 x 4 x Gr. 5-1.5
87	532 17 18-77	Bolt 5/16-18 unc x 3/4 w/Sems
90	817 00 06-16	Screw 3/8-16 x 1.0
92	817 12 06-16	Screw 3/8-16 x 1
94	532 18 86-54	Tube Extension Kohler Courage
96	819 09 14-16	Washer 9/32 x 7/8 x 16 Ga.
97	817 67 04-12	Screw 1/4-20 x 3/4
122	532 42 19-22	Extension Drain Oil

NOTE: All component dimensions given in U.S. inches
1 inch = 25.4 mm

For engine service and replacement parts, call the toll free
number for your engine manufacturer listed below:

Kohler Co. 1-800-544-2444

TRACTOR -- MODEL NUMBER YP18KH38 (96041031200), PRODUCT NO. 960 41 03-12
STEERING

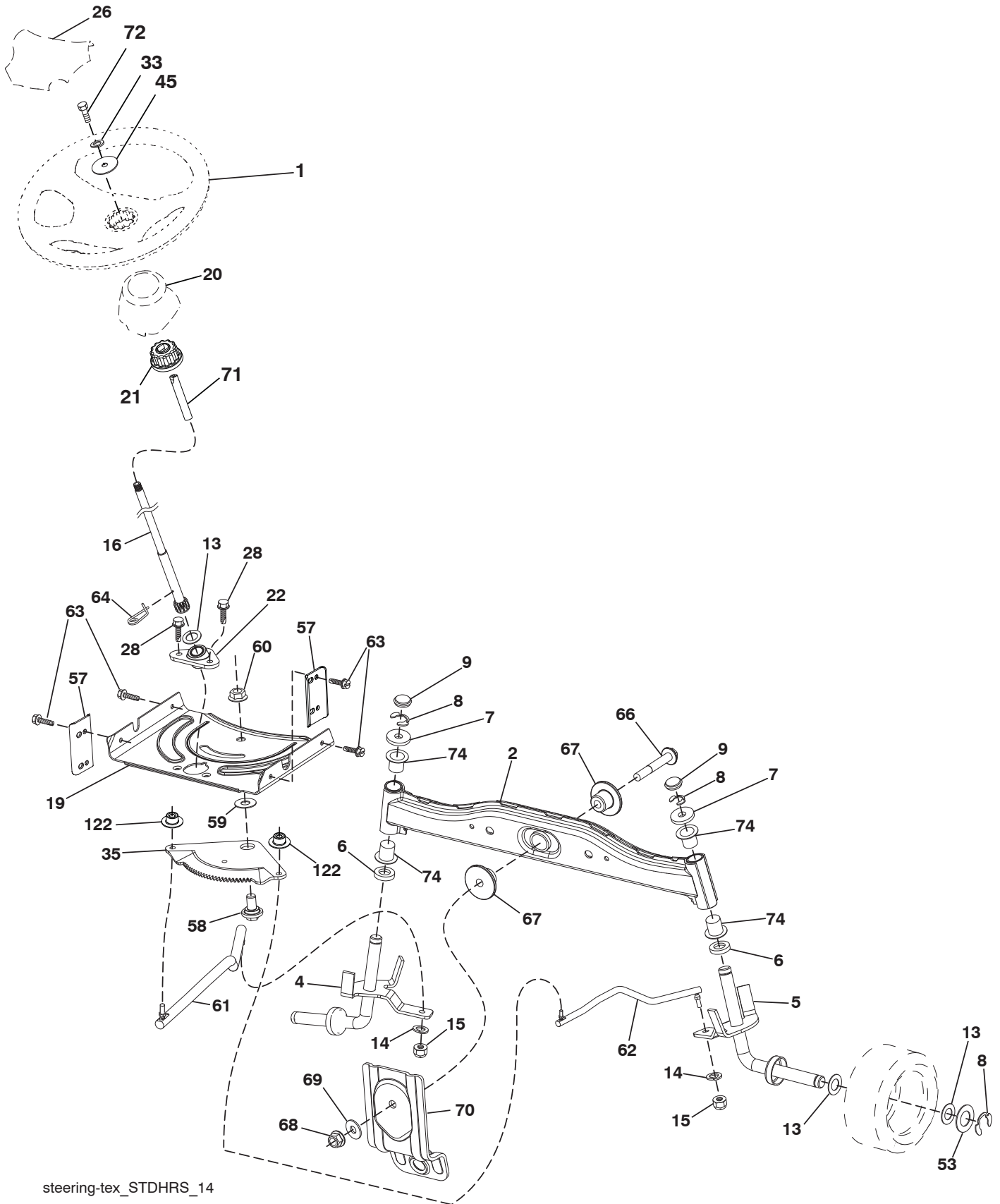

steering-tex_STDHRS_14

**TRACTOR - - MODEL NUMBER YP18KH38 (96041031200), PRODUCT NO. 960 41 03-12
STEERING**

KEY NO.	PART NO.	DESCRIPTION
1	532 42 45-43	Wheel, Steering
2	532 41 81-68	Axle Asm., Front
4	532 40 30-87	Spindle Asm., LH
5	532 40 30-88	Spindle Asm., RH
6	532 12 49-31	Washer Thrust 0.75 x 1.23
7	532 12 17-48	Washer 25/32 x 1-5/8 x 16 Ga.
8	812 00 00-29	Ring, Clip #T5304-75
9	532 12 12-32	Cap, Spindle
13	532 12 17-49	Washer 25/32 x 1-1/4 x 16 Ga.
14	810 04 06-00	Washer Lock 3/8
15	873 54 06-00	Nut, Crown Lock 3/8-24 unf
16	532 42 93-73	Shaft Steering
19	532 19 47-29	Plate Steering
20	532 41 12-91	Boot, Steering
21	532 18 67-37	Adapter, Wheel Steering
22	532 42 05-37	Strg. Supt. Lower
26	532 42 46-91	Insert, Wheel Steering
28	817 00 06-12	Screw 3/8-16 x 3/4
33	810 04 05-00	Washer Lock 5/16
35	532 19 47-32	Gear, Sector Plate
45	819 11 38-12	Washer 11/32 x 2-3/8 x 12 Ga.
53	532 18 89-67	Washer Hardened .793 x 1.637 x .060
57	532 40 74-65	Bracket Upstop
58	532 19 47-47	Bolt Shoulder Sector Pivot CFM
59	532 19 47-48	Washer Thrust Sector Steering
60	873 97 10-00	Nut Flange Lock 5/8-11
61	532 19 47-40	Draglink, LH
62	532 19 47-41	Draglink, RH
63	817 00 05-12	Screw 5/16-18 x 3/4
64	532 19 98-49	Retainer Clip Spring Steering
66	871 02 07-48	Bolt Hex Fghd 7/16-14 x 3 Serr
67	532 19 47-37	Bushing PM Front Axle
68	873 90 07-00	Nut Lock Flange 7/16-14 Gr. 5
69	532 19 91-62	Washer 1.5 x .505 x .118
70	532 19 61-97	Bracket Deck Susp. Front
71	532 19 07-52	Shaft Ext. Steering
72	532 42 89-82	Bolt 5/16-18 x 4 W/Patch
74	532 12 49-37	Bearing
122	532 44 49-62	Cap Gear

NOTE: All component dimensions given in U.S. inches
1 inch = 25.4 mm

TRACTOR - - MODEL NUMBER YP18KH38 (96041031200), PRODUCT NO. 960 41 03-12
MOWER DECK

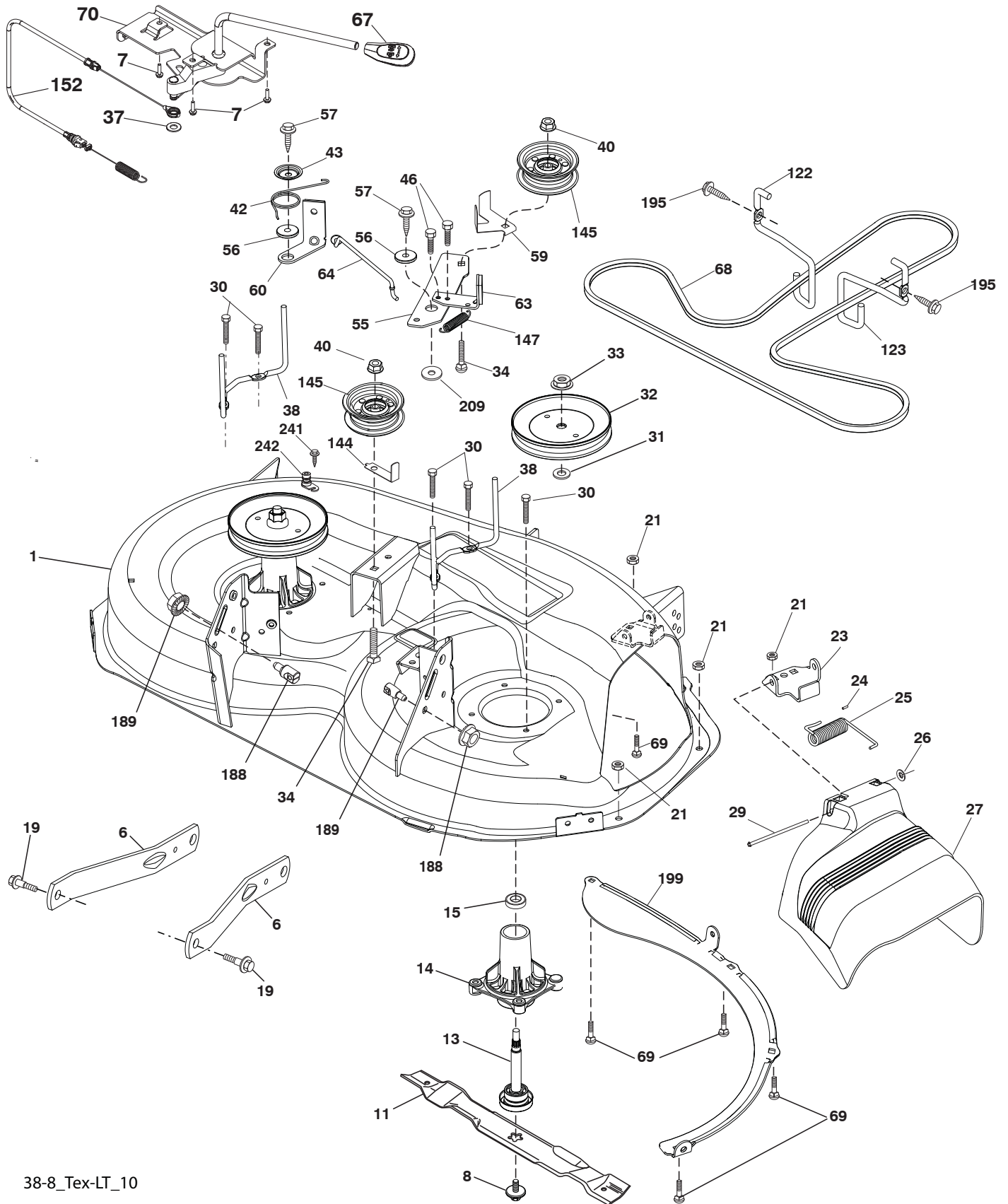

38-8_Tex-LT_10

**TRACTOR - - MODEL NUMBER YP18KH38 (96041031200), PRODUCT NO. 960 41 03-12
MOWER DECK**

KEY NO.	PART NO.	DESCRIPTION	KEY NO.	PART NO.	DESCRIPTION
1	532 19 42-51	Mower Housing	60	532 19 94-71	Arm Brake Mower
6	532 19 51-86	Arm Suspension	63	532 19 94-70	Arm Brake Mower
7	532 41 63-58	Screw #10 x 0.750 BOS Thread	64	532 19 97-90	Link Brake
8	532 19 30-03	Bolt/Washer Asm 7/16-20 unf	67	532 40 30-12	Handle Clutch Cable
11	532 19 39-57	Blade	68	532 40 83-81	V-Belt
13	532 19 28-72	Shaft Assembly, Mandrel	69	872 14 05-05	Bolt
14	532 18 72-81	Housing, Mandrel	70	532 19 83-32	Clutch Asm Manual
15	532 11 04-85	Bearing, Ball, Mandrel	122	532 19 72-58	Keeper Belt Engine LH
19	532 19 65-39	Bolt, Shoulder	123	532 19 72-59	Keeper Belt Engine RH
21	873 68 05-00	Nut, Crownlock 5/16-18 unc	144	532 19 34-14	Keeper Belt
23	532 19 25-57	Bracket, Deflector	145	532 19 31-97	Pulley, Idler, Flat
24	532 10 53-04	Cap, Sleeve	147	532 40 18-72	Spring Return
25	532 19 70-26	Spring, Torsion, Deflector	152	532 43 51-11	Manual Clutch Cable
26	532 11 04-52	Nut, Push	188	532 19 51-61	Stud Fastener
27	532 19 39-68	Shield, Deflector	189	873 90 05-00	Nut Lock Hex Flange
29	532 13 14-91	Rod, Hinge	195	817 00 06-12	Screw 3/8-16 x 3/4
30	532 17 39-84	Screw Thdrol Rolling Wsh Hd	199	532 40 00-95	Baffle Vortex
31	532 18 76-90	Washer, Spacer	209	819 13 32-10	Washer 13/32 x 2 x 10
32	532 19 97-89	Pulley, Mandrel	241	532 15 29-27	Screw TT #10-32.5.3/8 Flange
33	532 40 02-34	Nut, Toplock, Flanged	242	532 41 55-98	Port Washout
34	872 11 06-12	Bolt Carr Sh. 3/8-16 x 1-1/2 Gr. 5	--	532 19 28-70	Mandrel Assembly (Includes housing, shaft assembly, and bearing only - pulley/nut/washer and blade bolt/washers not included)
37	819 13 13-16	Washer	--	532 43 54-93	Replacement Mower, Complete
38	532 19 95-41	Keeper Belt LH Mandrel			
40	873 90 06-00	Nut, Lock Flg. 3/8-16 unc			
42	532 19 84-10	Spring Torsion Brake			
43	532 19 72-56	Spring Torsion Retainer			
46	532 13 77-29	Screw 1/4-20 x 5/8			
55	532 19 72-49	Arm, Idler			
56	532 19 90-92	Spacer, Retainer			
57	817 00 06-16	Screw 3/8-16 x 1			
59	532 14 10-43	Guard, Tuv Idler			

NOTE: All component dimensions given in U.S. inches
1 inch = 25.4 mm

**TRACTOR - - MODEL NUMBER YP18KH38 (96041031200), PRODUCT NO. 960 41 03-12
MOWER LIFT**

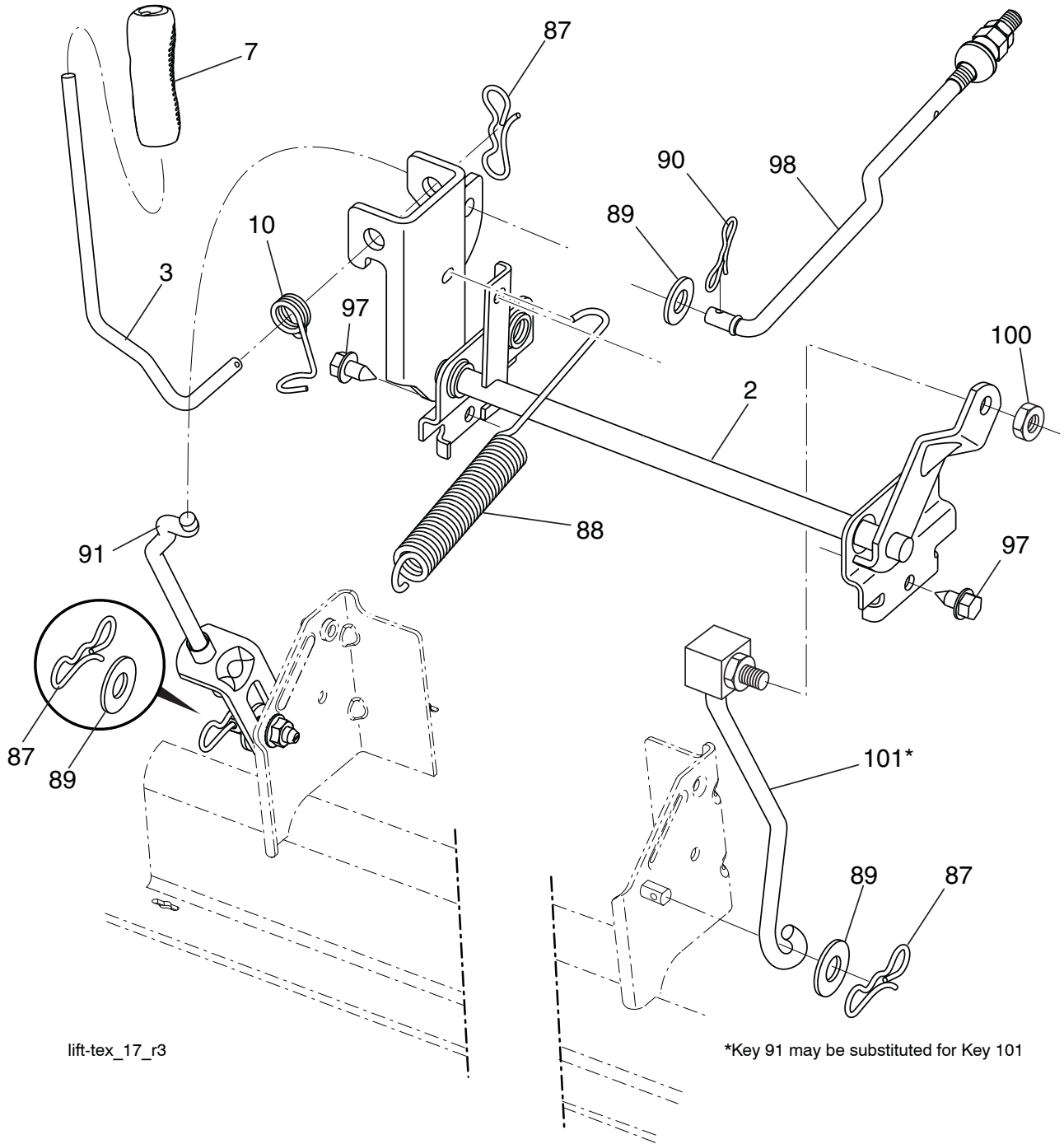

lift-tex_17_r3

*Key 91 may be substituted for Key 101

KEY NO.	PART NO.	DESCRIPTION
2	532 42 20-27	Shaft Asm., Cross Lift
3	532 19 52-31	Lever Asm., Lift RH
7	580 96 23-01	Grip, Lever
10	532 19 63-14	Spring Torsion
87	532 19 42-09	Pin Cotter 7/16 Bow Tie Lock
88	532 41 07-10	Spring Lift Assist
89	819 19 19-12	Washer Clear Zinc
90	532 19 42-08	Pin Cotter 5/16 Bow Tie Lock

KEY NO.	PART NO.	DESCRIPTION
91	532 19 51-81	Link Lift Susp Mower Rear
97	817 00 06-12	Screw 3/8-16 x .75 Smgml Tap/R.Z
98	532 19 52-70	Link Lift Susp. Front Mower
100	873 93 06-00	Nut Centerlock 3/8 -16 unc
101	532 40 70-03	Link Asm. Lift Fixed

NOTE: All component dimensions given in U.S. inches
1 inch = 25.4 mm

**TRACTOR - - MODEL NUMBER YP18KH38 (96041031200), PRODUCT NO. 960 41 03-12
SEAT**

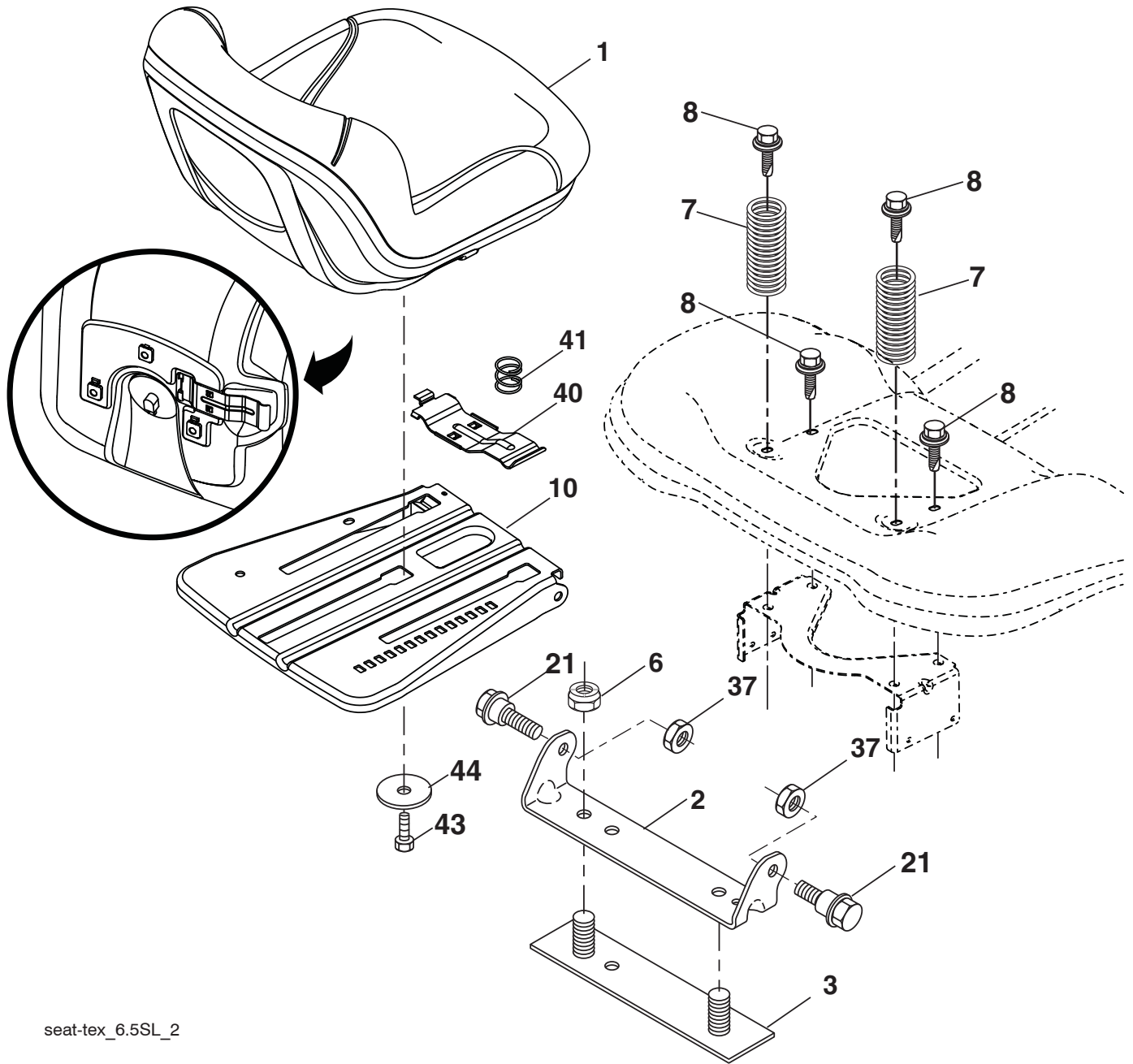

seat-tex_6.5SL_2

KEY NO.	PART NO.	DESCRIPTION
1	532 41 14-05	Seat
2	532 18 01-66	Bracket Pivot Fender
3	532 14 06-75	Strap, Asm Fender
6	873 80 06-00	Nut, Lock w/Ins. 3/8-16 unc
7	532 12 41-81	Spring, Seat Cprsn
8	532 17 18-77	Bolt 5/16-18 unc x 3/4 w/Sems
10	532 19 69-77	Pan, Seat
21	532 17 18-52	Bolt, Shoulder 5/16-18

KEY NO.	PART NO.	DESCRIPTION
37	873 80 05-00	Nut, Lock 5/16-18 unc
40	532 19 76-61	Handle Slide
41	532 19 82-00	Spring Latch
43	874 76 06-12	Bolt 3/8-16 unc x 3/4
44	819 13 38-12	Washer 13/32 x 2 3/8 x 12 Ga.

NOTE: All component dimensions given in U.S. inches
1 inch = 25.4 mm

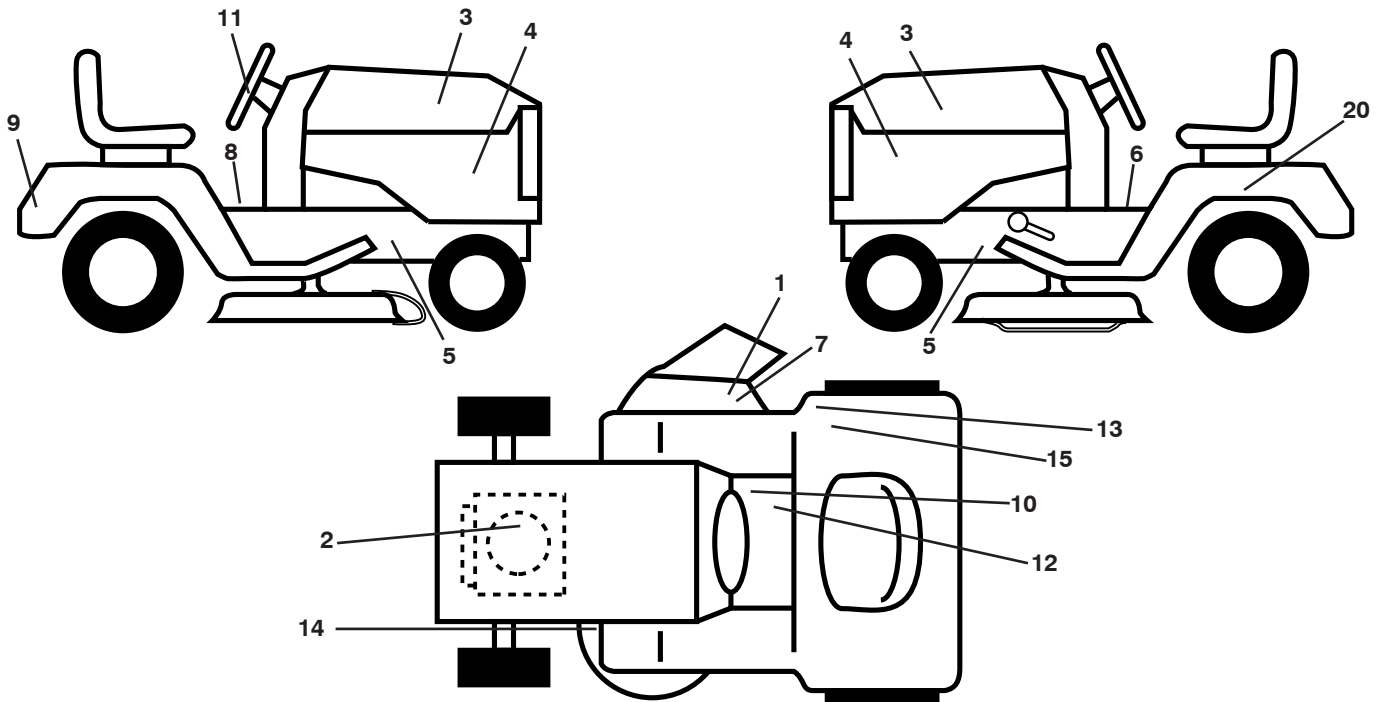

KEY NO.	PART NO.	DESCRIPTION
1	532 18 21-66	Decal Cut Finger
2	532 19 68-41	Decal Engine
3	532 43 92-76	Decal Hood
4	581 01 61-01	Decal Side Panel
5	532 15 97-36	Decal Chassis Hot Muffler
6	532 15 97-37	Decal Brake/Clutch Symbol
7	532 19 63-57	Decal Deflector Warning
8	532 40 03-89	Decal Fender Warning
9	532 43 92-98	Decal Fender Logo
10	532 14 08-37	Decal Saddle Brake Parking
11	532 43 92-82	Decal Ins Strg Whl

KEY NO.	PART NO.	DESCRIPTION
12	532 17 83-02	Decal Pedal Symbol
13	532 12 44-33	Decal 80 DBA Adjust.
14	532 19 43-02	Decal V-Belt Schematic
15	532 16 88-69	Decal Tick Mark
20	532 14 50-05	Decal Bat Dan/Psn
--	532 16 25-98	Decal Drawbar Load Limit
--	532 16 69-60	Decal Bypass
--	532 40 95-05	Pad Footrest LH
--	532 40 95-07	Pad Foot Pedal
--	581 04 31-26	Manual Operator's
--	581 04 32-26	Manual Parts

WHEELS AND TIRES

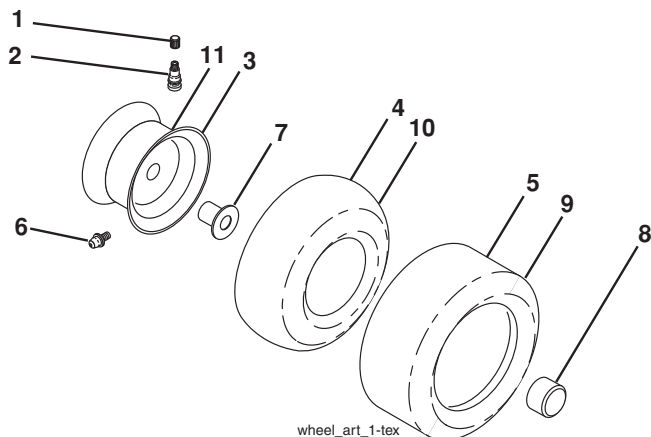

KEY NO.	PART NO.	DESCRIPTION
1	532 05 91-92	Cap Valve Tire
2	532 06 51-39	Stem Valve
3	532 43 96-73	Rim Asm 6" Front
4	532 05 99-04	Tube Front (Service Item Only)
5	532 10 62-22	Tire F T 15 x 6 0 - 6
6	532 12 49-57	Fitting Grease
7	532 12 49-59	Bearing Flange (Front Wheel Only)
8	532 17 50-39	Cap Axle
9	532 13 84-68	Tire R T 20 x 8-8C
10	532 12 49-26	Tube Rear (Service Item Only)
11	532 44 08-81	Rim Asm 8" Rear Service
--	532 14 43-34	Sealant, Tire (Not Shown)

NOTE: All component dimensions given in U.S. inches
1 inch = 25.4 mm

SERVICE NOTES

LIMITED WARRANTY

The Manufacturer warrants to the original consumer purchaser that this product as manufactured is free from defects in materials and workmanship. For a period of two (2) years from date of purchase by the original consumer purchaser, we will repair or replace, at our option, without charge for parts or labor incurred in replacing parts, any part which we find to be defective due to materials or workmanship. This Warranty is subject to the following limitations and exclusions.

1. This warranty does not apply to the engine, transaxle/transmission components, battery (except as noted below) or components parts thereof. Please refer to the applicable manufacturer's warranty on these items.
2. Transportation charges for the movement of any power equipment unit or attachment are the responsibility of the purchaser. Transportation charges for any parts submitted for replacement under this warranty must be paid by the purchaser unless such return is requested by the manufacturer.
3. Battery Warranty: On products equipped with a Battery, we will replace, without charge to you, any battery which we find to be defective in manufacture, during the first ninety (90) days of ownership. After ninety (90) days, we will exchange the Battery, charging you 1/12 of the price of a new Battery for each full month from the date of the original sale. Battery must be maintained in accordance with the instructions furnished.
4. The Warranty period for any products used for rental or commercial purposes is limited to 90 days from the date of original purchase.
5. This Warranty applies only to products which have been properly assembled, adjusted, operated, and maintained in accordance with the instructions furnished. This Warranty does not apply to any product which has been subjected to alteration, misuse, abuse, improper assembly or installation, delivery damage, or to normal wear of the product.
6. Exclusions: Excluded from this Warranty are belts, blades, blade adapters, normal wear, normal adjustments, standard hardware and normal maintenance.
7. In the event you have a claim under this Warranty, you must return the product to an authorized service dealer.

Should you have any unanswered questions concerning this Warranty, please contact:

HOP
Outdoor Products Customer Service Dept.
9335 Harris Corners Parkway
Charlotte, NC 28269 USA

In Canada contact:
HOP
5855 Terry Fox Way
Mississauga, Ontario
L5V 3E4

giving the model number, serial number and date of purchase of your product and the name and address of the authorized dealer from whom it was purchased.

THIS WARRANTY DOES NOT APPLY TO INCIDENTAL OR CONSEQUENTIAL DAMAGES AND ANY IMPLIED WARRANTIES ARE LIMITED TO THE SAME TIME PERIODS STATED HEREIN FOR OUR EXPRESSED WARRANTIES. Some areas do not allow the limitation of consequential damages or limitations of how long an implied Warranty may last, so the above limitations or exclusions may not apply to you. This Warranty gives you specific legal rights, and you may have other rights which vary from locale to locale.

This is a limited Warranty within the meaning of that term as defined in the Magnuson-Moss Act of 1975.

Yard Pro