

ILLUSTRATED PARTS LIST

MODEL NO. 96041020503

CUSTOMER CATALOG NO. LTH126

PRODUCT NO. 960 41 02-05

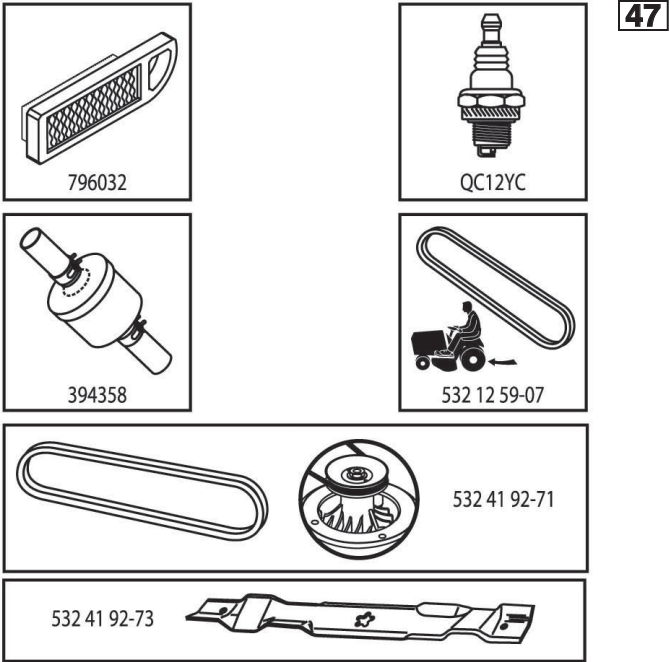

**TRACTOR - - MODEL NO. LTH126 (96041020503), PRODUCT NO. 960 41 02-05
DECALS 27**

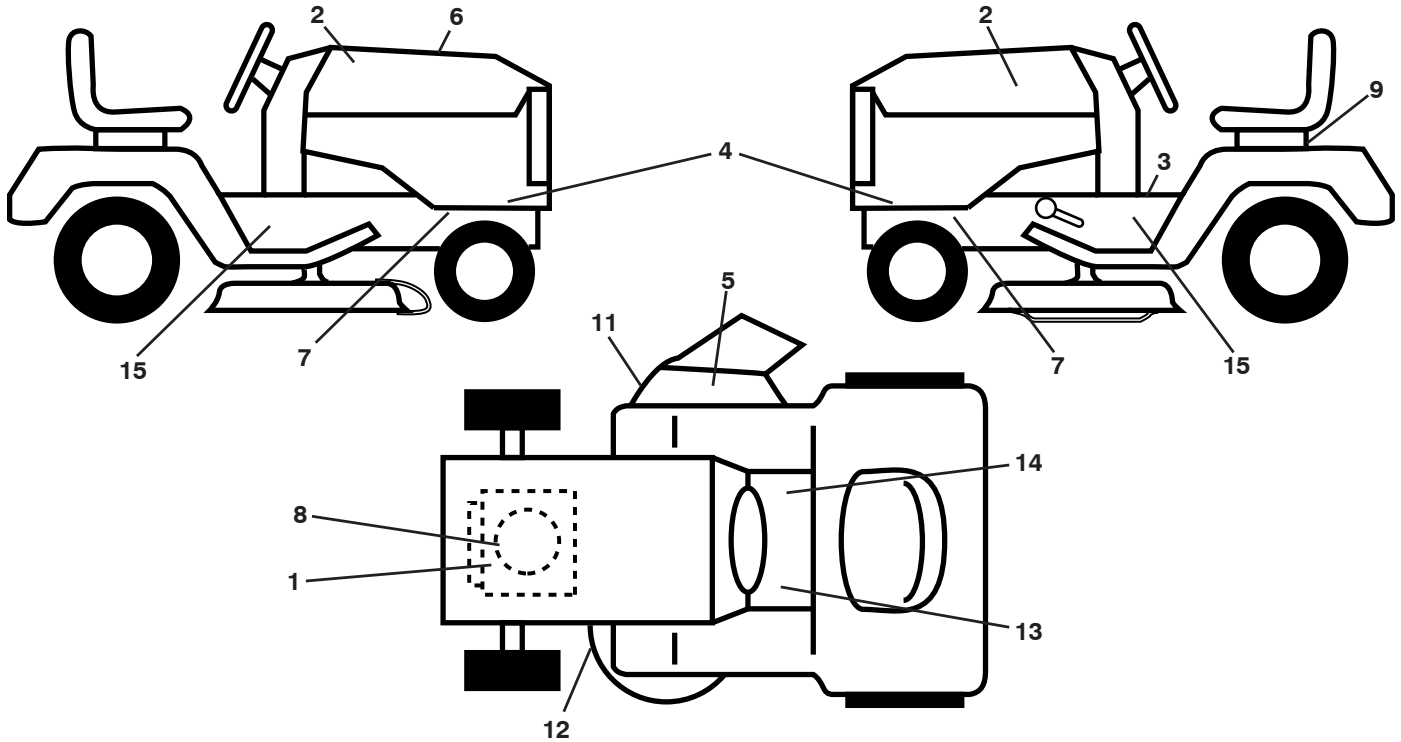

KEY NO.	PART NO.	DESCRIPTION
1	581 57 97-01	Decal, Warning Engine
2	581 62 73-01	Hood Emblem
3	581 57 81-01	Decal, Warning Symbols
4	532 43 79-19	Decal, Hood Panel Side
5	584 90 46-01	Decal, Deflect. Warning
6	532 44 25-47	Decal, Replacement
7	581 57 96-01	Decal, Chassis Hot Muffler
8	532 43 74-10	Decal, Engine
9	532 14 50-05	Decal, Battery Dnge/Poi
11	581 57 93-01	Decal, Warning Deflect/Cutfinger

KEY NO.	PART NO.	DESCRIPTION
12	581 58 00-04	Decal, Mower V-Belt Schematic
13	581 72 40-01	Decal, Brake/Clutch
14	581 57 80-01	Decal, Saddle Brake Parking
15	581 57 98-01	Decal, Warning Service/Fire
--	581 72 48-01	Decal, Bypass
--	581 72 46-01	Decal, Drawbar Load Limit
--	532 43 96-81	Pad, Footrest, LH
--	532 43 96-82	Pad, Footrest, RH
--	532 44 49-21	Manual, Operator's (Euro)

WHEELS AND TIRES

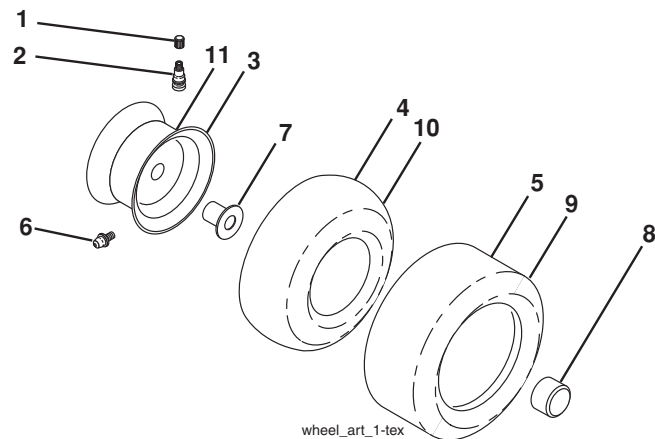

KEY NO.	PART NO.	DESCRIPTION
1	532 05 91-92	Cap Valve Tire
2	532 06 51-39	Stem Valve
3	532 42 52-61	Rim Asm 6" x 3.25 Front
4	532 42 16-52	Tube Front (Service Item Only)
5	532 12 34-10	Tire Front 13 x 5.0-6
6	532 12 49-57	Fitting Grease (Front Wheel Only)
7	532 12 49-59	Bearing Flange (Front Wheel Only)
8	532 17 50-39	Cap Axle Blk 1 50 x 1 00
9	532 10 62-30	Tire Rear 16 x 6 - 5
10	532 00 71-54	Tube Rear (Service Item Only)
11	532 42 52-62	Rim Asm 8" x 5.375 Rear
--	532 14 43-34	Sealant, Tire (10 oz. Tube)

NOTE: All component dimensions given in U.S. inches
1 inch = 25.4 mm

TRACTOR - - MODEL NO. LTH126 (96041020503), PRODUCT NO. 960 41 02-05

SCHEMATIC **38**

SCH12

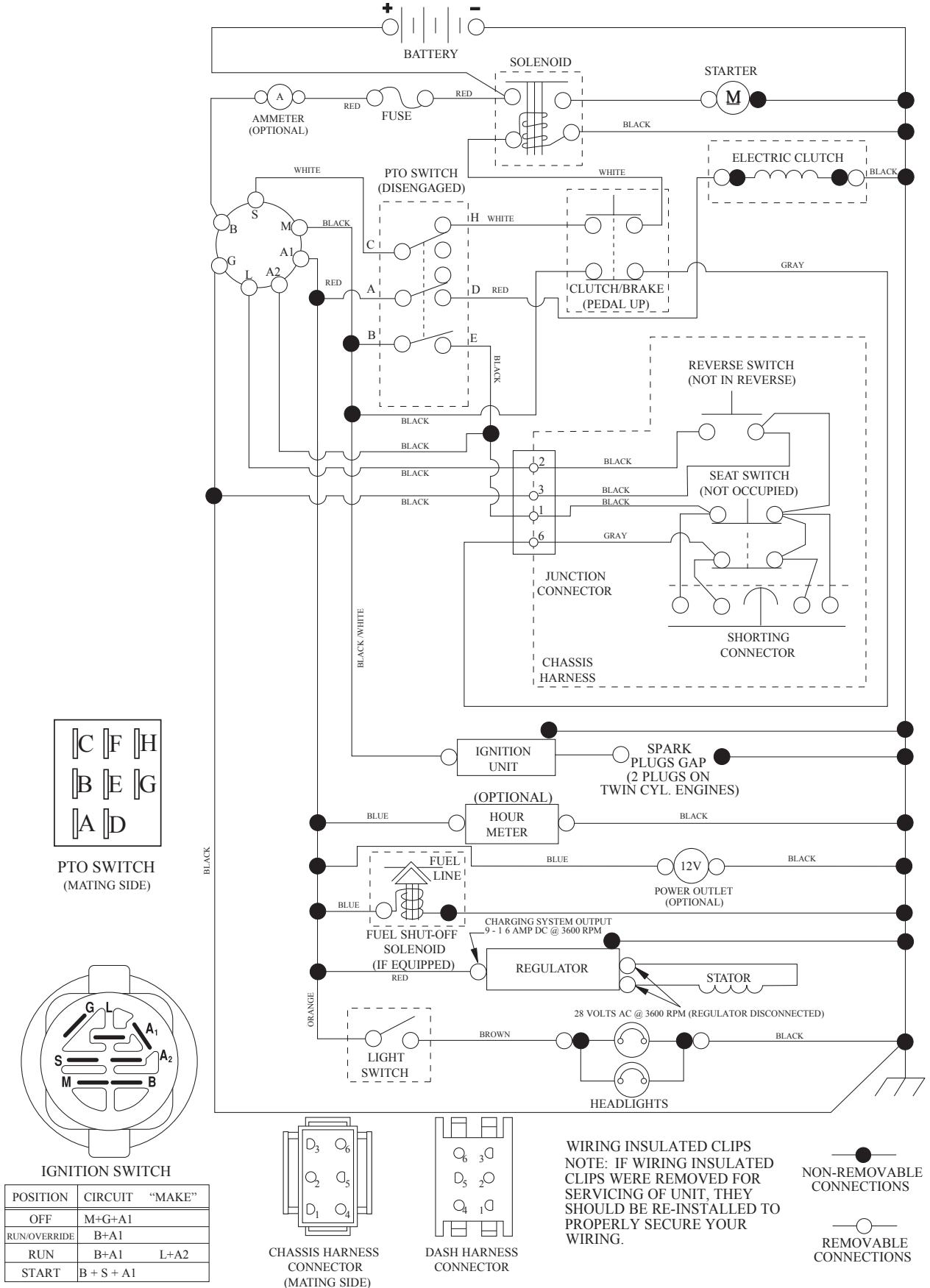

TRACTOR - - MODEL NO. LTH126 (96041020503), PRODUCT NO. 960 41 02-05
ELECTRICAL 32

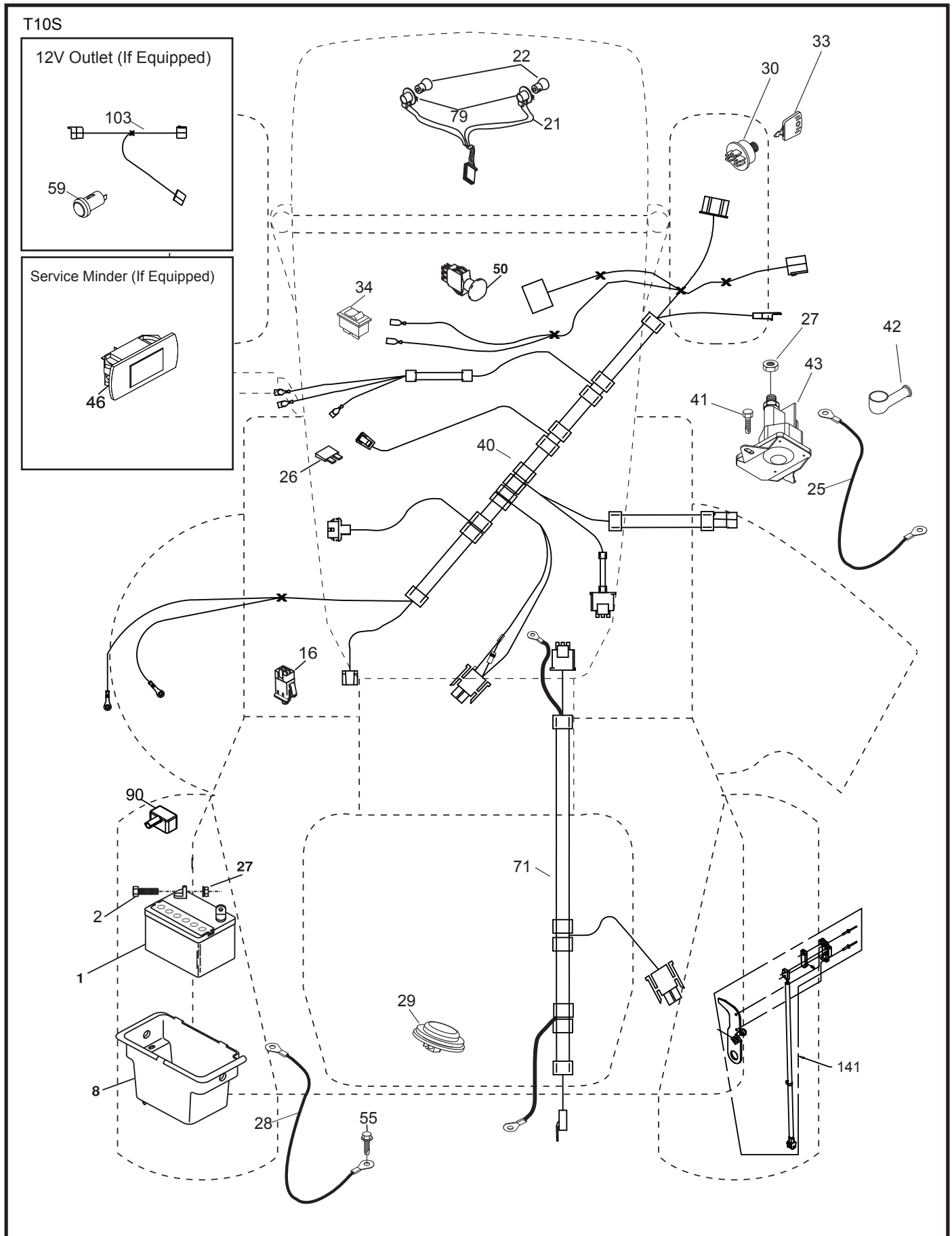

**TRACTOR - - MODEL NO. LTH126 (96041020503), PRODUCT NO. 960 41 02-05
ELECTRICAL 32**

KEY NO.	PART NO.	DESCRIPTION
1	532 16 34-65	Battery
2	874 76 04-12	Bolt Hex Head 1/4-20 x 3/4
8	532 19 32-28	Box Battery
16	532 17 61-38	Switch Interlock Push-In
21	532 40 02-52	Harness Socket Light w/4152J
22	532 00 41-52	Bulb Light
25	585 55 54-01	Cable Starter
26	532 17 51-58	Fuse
27	873 51 04-00	Nut Keps Hex 1/4-20 unc
28	532 19 88-85	Cable, Ground
29	532 40 15-45	Switch, Seat
30	532 19 33-50	Switch, Ign
33	532 41 19-35	Key/Chain
34	532 11 07-12	Switch Light/Reset
40	532 40 11-04	Harness Ign. Dash
41	817 72 04-08	Screw
42	532 13 15-63	Cover
43	532 19 25-07	Solenoid
46	532 40 17-63	Gauge Hourmeter
50	532 17 46-51	Switch PTO
55	817 06 05-12	Screw Thdrol 5/16-18 x 3/4
71	532 44 15-44	Harness Chassis
79	532 17 52-42	Socket Asm Bulb Twistlock
90	532 43 53-95	Cover, Terminal Battery
141	532 41 69-77	Kit T2 ROS

NOTE: All component dimensions given in U.S. inches
1 inch = 25.4 mm

TRACTOR - - MODEL NO. LTH126 (96041020503), PRODUCT NO. 960 41 02-05
CHASSIS AND ENCLOSURES 39

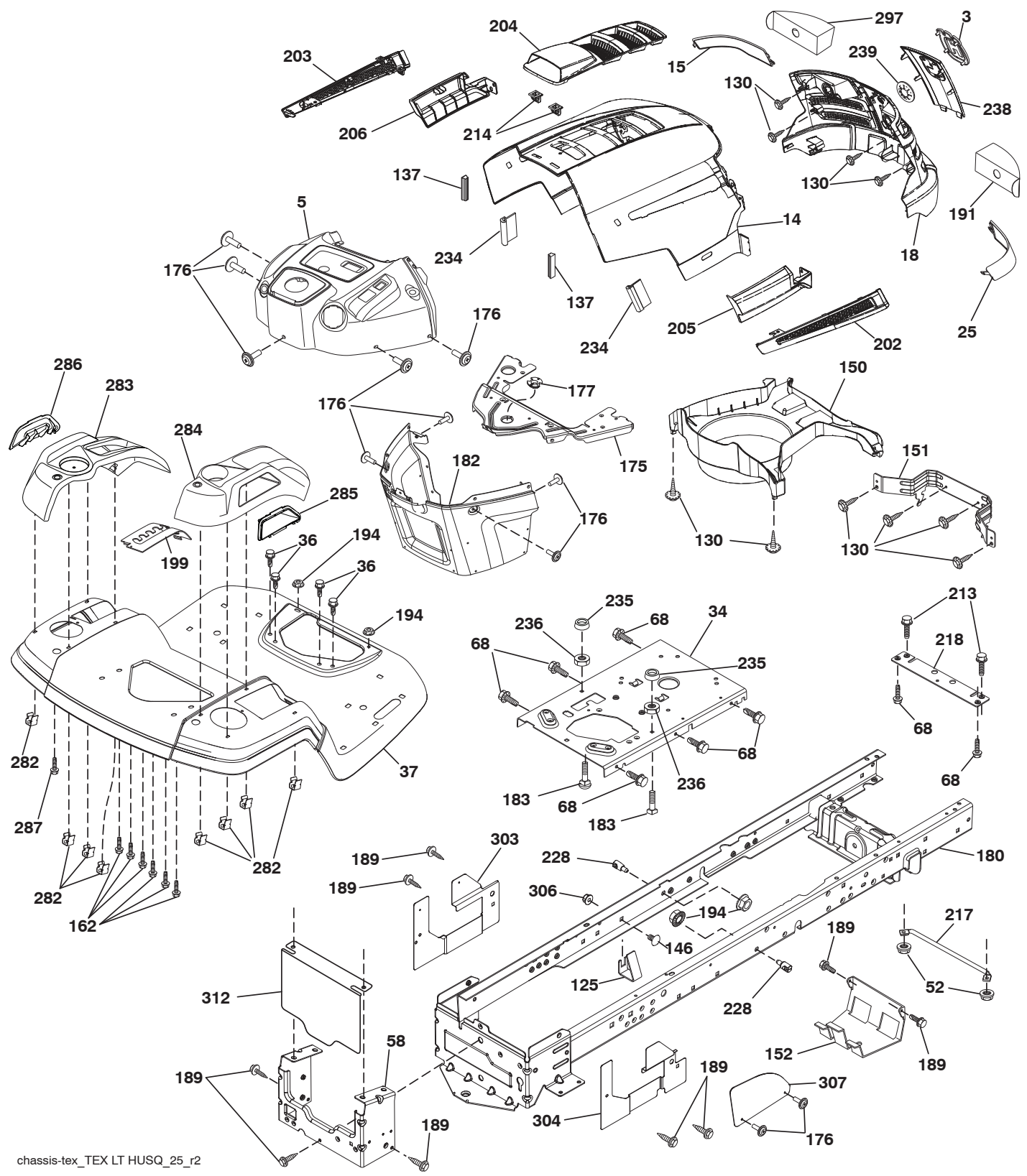

chassis-tex_TEX LT HUSQ_25_r2

**TRACTOR - - MODEL NO. LTH126 (96041020503), PRODUCT NO. 960 41 02-05
CHASSIS AND ENCLOSURES 39**

KEY NO.	PART NO.	DESCRIPTION	KEY NO.	PART NO.	DESCRIPTION
3	581 05 63-01	Logo	203	532 44 13-43	Vent Side Hood LH
5	532 43 89-66	Dash	204	532 44 13-75	Vent Top Hood
14	532 44 12-67	Hood	205	532 44 13-44	Skirt Side RH
15	532 44 14-28	Lens LH	206	532 44 13-45	Skirt Side LH
18	532 44 13-68	Grille	213	874 76 05-12	Bolt 5/16-18 x 3/4
25	532 44 14-27	Lens RH	214	532 19 91-45	Clip Retainer
34	580 91 08-01	Plate Engine	217	532 40 91-67	Rod Pivot Hood
36	817 06 05-12	Screw 5/16-18 x 3/4	218	532 19 63-95	X-Piece Hood Stop
37	532 44 12-66	Fender	228	532 19 51-61	Stud Fastener
52	873 68 05-00	Nut Crown Lock 5/16	234	532 40 47-42	Bumper Hood
58	532 41 22-80	Drawbar, Upper	235	532 40 61-29	Spacer Fender
68	817 49 05-08	Screw THDROL 5/16-18 x 1/2	236	873 93 05-00	Nut Lock 5/16-18 unc
125	581 68 48-01	Clip Fuel Line	238	532 44 13-74	Trim
130	532 41 63-58	Screw #10 x .750 BOS Thread	239	532 40 48-83	Clip Tinnerman
137	532 40 75-90	Bumper Dash	282	532 41 41-10	Clip Retainer Console
146	581 85 79-01	Bolt	283	532 44 20-39	Console Deck Lift
150	532 40 66-62	Air Duct	284	532 43 98-23	Console Shift
151	532 40 78-07	Bracket Pivot	285	532 41 63-15	Console Insert RH
152	532 19 95-35	Shield Browning	286	532 41 63-17	Console Insert LH
162	532 14 24-32	Screw	287	817 60 04-06	Screw Hex Washhead 1/4-20 x 3/8
175	532 19 94-72	Crossmember	297	532 40 66-65	Insert Reflective LH
176	532 40 07-76	Screw 10-24 x 5/8	303	532 42 51-51	Shield Chassis French LH
177	532 19 52-28	Bushing Steering	304	532 42 51-52	Shield Chassis French RH
180	532 41 46-85	Chassis	306	873 90 06-00	Nut Lock
182	532 40 71-76	Dash Lower	307	532 42 45-70	Shield Upper Pedal
183	874 52 05-20	Bolt Full Thread 5/16-18 x 1-1/4	312	532 42 59-26	Shield Drawbar
189	817 00 05-12	Screw 5/16-18 x 3/4			
191	532 41 65-01	Insert Reflective RH			
194	873 90 05-00	Nut Lock Hex Flange 5/16-18			
199	532 41 34-85	Plate Deck Lift			
202	532 44 13-42	Vent Side Hood RH			

NOTE: All component dimensions given in U.S. inches
1 inch = 25.4 mm

TRACTOR - - MODEL NO. LTH126 (96041020503), PRODUCT NO. 960 41 02-05
DRIVE 40

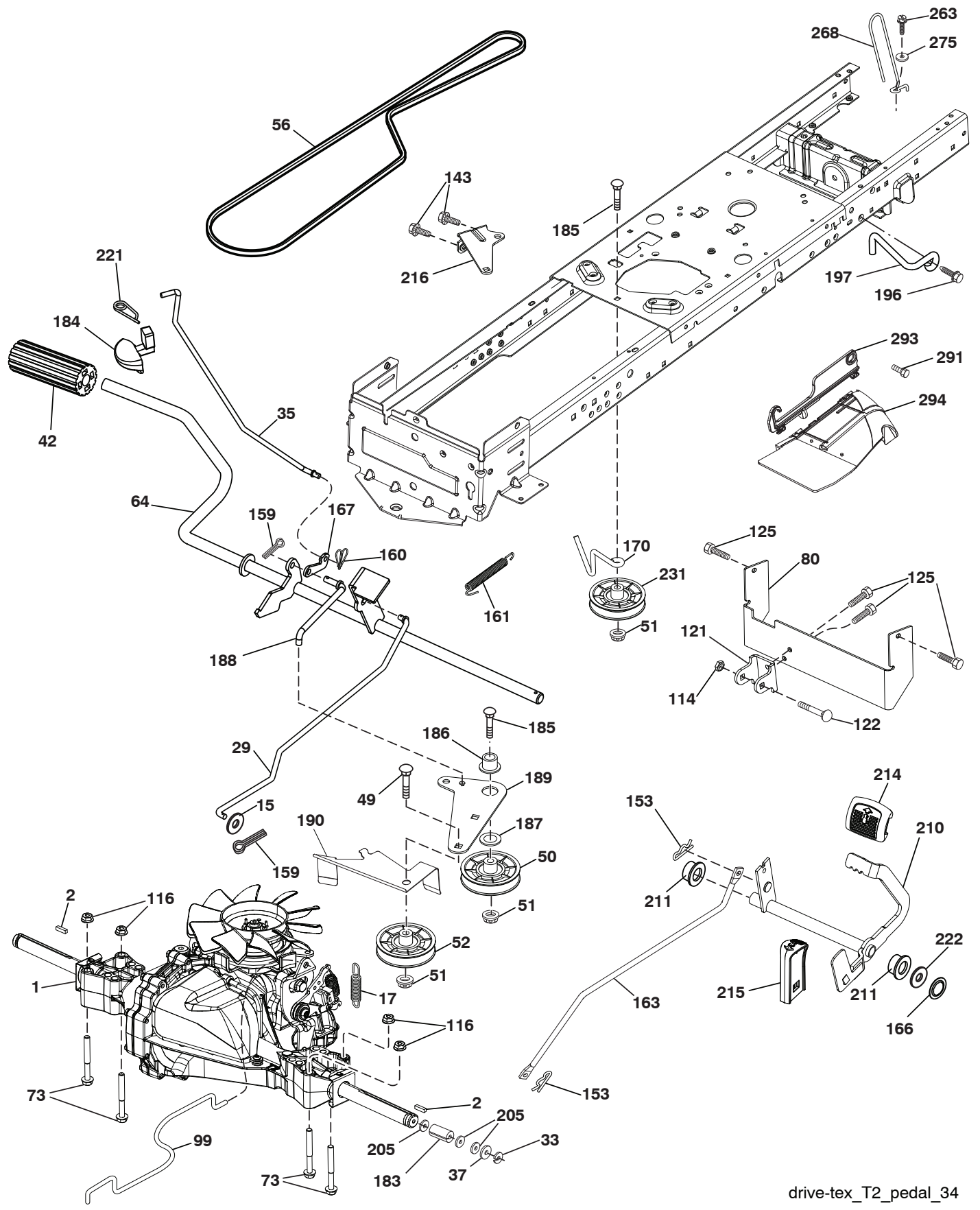

drive-tex_T2_pedal_34

**TRACTOR - - MODEL NO. LTH126 (96041020503), PRODUCT NO. 960 41 02-05
DRIVE 40**

KEY NO.	PART NO.	DESCRIPTION	KEY NO.	PART NO.	DESCRIPTION
1	---	Transaxle, Hydro Gear T2-BDBE-1X2B-18X1 (587392201) (Order parts from transaxle manufacturer.)	167	532 40 52-57	Latch Brake Parking
2	532 12 35-83	Key	170	532 41 34-30	Keeper Belt Centerspan
15	819 13 13-16	Washer 13/32 x 13/16 x 16 Ga.	183	532 15 69-72	Spacer Axle
17	532 19 72-96	Spring, Brake	184	532 44 14-07	Handle Parking Brake
29	532 42 32-39	Rod, Brake	185	872 11 06-22	Bolt
33	812 00 00-01	Ring E	186	532 19 43-21	Spacer Retainer
35	532 40 10-31	Rod, Brake, Park	187	819 13 32-10	Washer
37	532 12 17-49	Washer 25/32 x 1-1/4 x 16 Ga.	188	532 19 43-23	Link Clutch Ground Drive
42	532 12 48-72	Cover, Foot Pedal	189	532 19 43-17	Bellcrank Ground Drive
49	872 11 06-14	Bolt	190	532 19 43-18	Keeper Bellcrank Ground Drive
50	532 19 43-27	Pulley Idler Flat	196	817 00 06-16	Screw 3/8-16 x 1
51	873 90 06-00	Lock Nut 3/8-16	197	585 65 86-01	Link Clutch Anti-Rotation
52	532 19 43-26	Idler V-Groove Offset	205	532 12 17-48	Washer 25/32 x 1-5/8 x 16 Ga.
56	532 12 59-07	V-Belt, Drive	210	532 40 09-80	Rockr Asm. Pdeal Control
64	532 19 78-65	Shaft Asm. Pedal Brake Control	211	532 12 01-83	Bearing Nylon
73	874 49 05-44	Bolt 5/16-18 Gr. 5	214	532 42 12-63	Pad Pedal Forward
80	581 55 07-01	Strap Torque	215	532 40 17-23	Pad Pedal Reverse
99	532 40 84-18	Rod Asm Bypass Spring	216	532 19 61-31	Bracket Pulley Idler
114	873 80 05-00	Nut Lock 5/16-18 unc	221	532 40 31-87	Retainer Spring Clip Handle
116	873 90 05-00	Nut Lock Hex Flange 5/16-18	222	879 21 20-10	Washer 21/32 x 1-1/4 10 Ga.
121	532 17 56-11	Bracket Strap Torque	231	532 40 72-87	Idler V-Groove 1.688
122	872 01 05-20	Bolt 5/16-18 x 2.50	263	817 00 06-12	Screw 3/8-16 x 3/4
125	817 00 05-12	Screw 5/16-18 x 3/4	268	532 18 24-02	Guard Muffler
143	817 49 05-08	Screw Thdrol 5/16-18 x 1/2	275	819 13 16-14	Washer 13/32 x 1 x 14 Ga.
153	532 12 47-88	Retainer Spring	291	532 17 01-65	Bolt Shoulder 5/16-18
159	876 02 04-12	Pin Cotter 1/8 x 3/4	293	532 42 25-48	Hinge RH French
160	532 16 94-84	Retainer Clip	294	532 43 03-03	Guard Asm RH
161	532 10 57-09	Spring, Return, Clutch			
163	532 41 33-22	Rod Pedal Control			
166	532 42 91-64	Nut Push .625			

NOTE: All component dimensions given in U.S. inches
1 inch = 25.4 mm

**TRACTOR - - MODEL NO. LTH126 (96041020503), PRODUCT NO. 960 41 02-05
ENGINE 24**

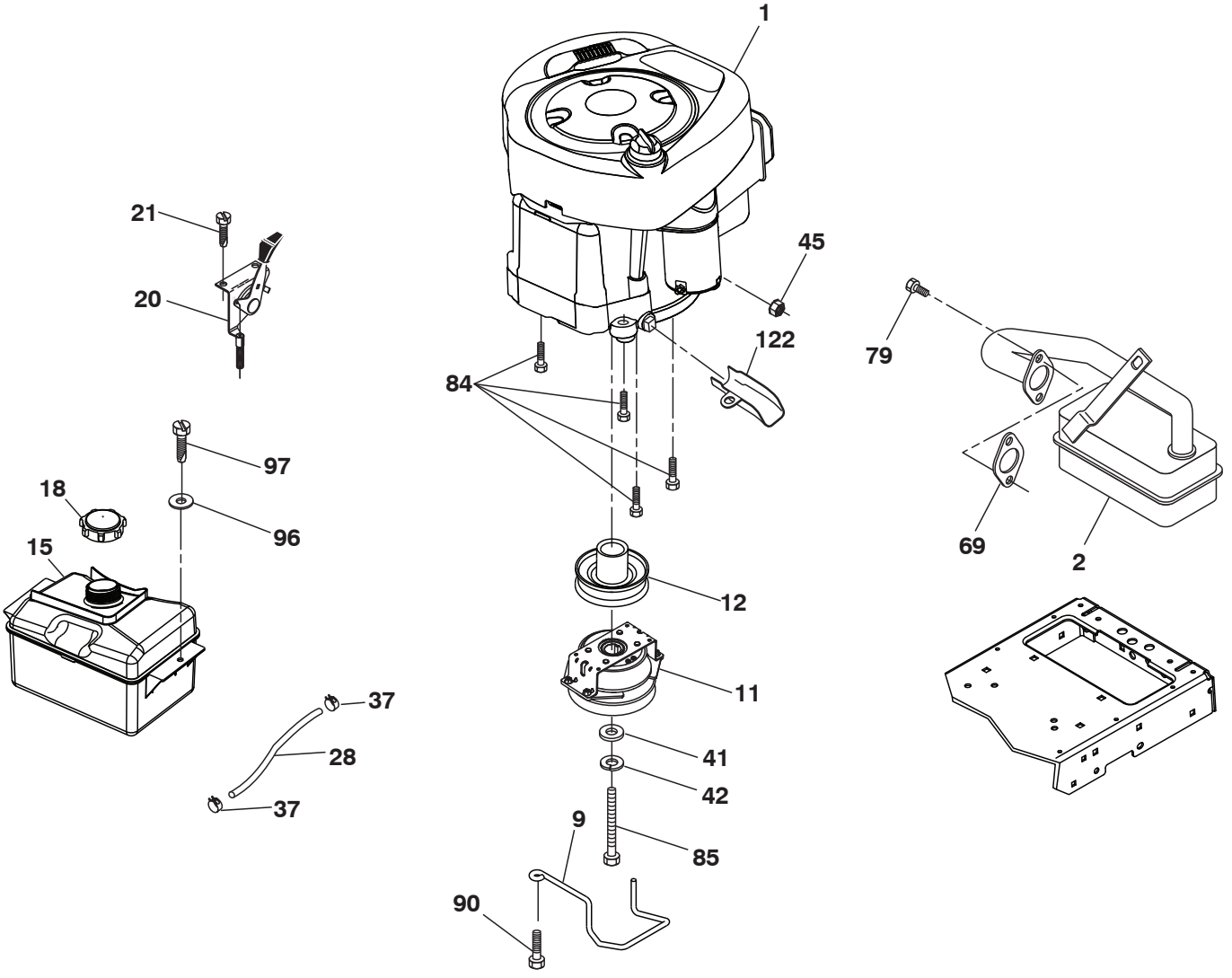

29

OPTIONAL EQUIPMENT
Spark Arrester

engine-tex_BS_99

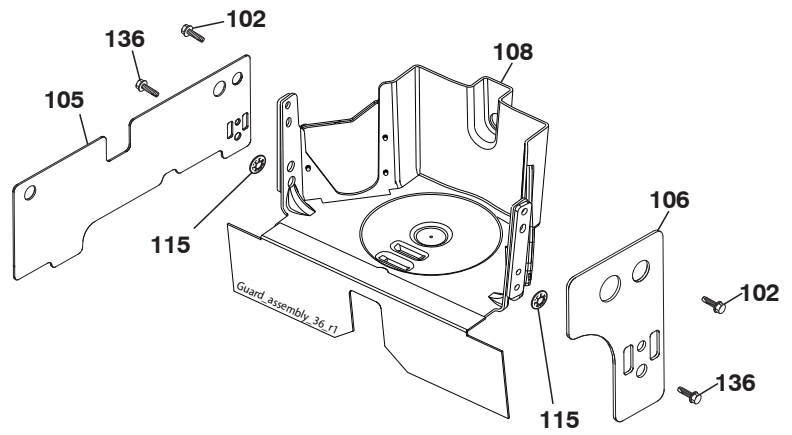

**TRACTOR - - MODEL NO. LTH126 (96041020503), PRODUCT NO. 960 41 02-05
ENGINE 24**

KEY NO.	PART NO.	DESCRIPTION
1	- - - - -	Engine Briggs Model No. 21R707-0006-B1(585403801) (Order parts from engine manufacturer)
2	532 17 97-58	Muffler
9	584 91 16-01	Keeper Belt Engine
11	587 24 15-01	Clutch Electric
12	532 40 29-80	Pulley Engine
15	532 40 75-45	Tank Fuel
18	532 43 02-20	Cap Fuel
20	532 18 38-97	Control Throttle
21	532 41 63-58	Screw #10 x 0.750 BOS Thread
28	532 13 70-40	Fuel Line
29	532 13 71-80	Spark Arrester Kit
37	532 12 34-87	Clamp Hose
41	532 12 61-97	Washer 1-1/2 OD x 15/32 ID x 250
42	810 04 07-00	Washer Lock 7/16
45	873 51 04-00	Nut Keps Hex 1/4-20 unc
69	532 16 52-91	Gasket
79	532 19 23-34	Screw 5/16-18 x 3/4
84	817 06 06-20	Screw 3/8-16 x 1/4
85	581 33 28-04	Bolt 7/16-20 x 3.5 Gr. 5
90	817 00 06-16	Screw 3/8-16 x 1
96	819 09 14-16	Washer 9/32 x 7/8 x 16 Ga.
97	817 67 04-12	Screw 1/4-20 x 3/4
102	817 00 05-12	Screw 5/16-18 x 3/4
105	532 42 08-94	Shield Side LH
106	532 43 02-57	Shield Side RH
108	532 43 16-89	Cover Pulley Engine
115	532 42 30-62	Pal Nut 1/4
122	532 42 19-22	Extension Drain Oil
136	532 13 77-29	Screw Thd Roll 1/4-20 x 5/8

NOTE: All component dimensions given in U.S. inches
1 inch = 25.4 mm

Engine Power Rating Information

The gross power rating for individual gas engine models is labeled in accordance with SAE (Society of Automotive Engineers) code J1940 (Small Engine Power & Torque Rating Procedure), and rating performance has been obtained and corrected in accordance with SAE J1995 (Revision 2002-05). Torque values are derived at 3060 RPM; horsepower values are derived at 3600 RPM. Actual gross engine power will be lower and is affected by, among other things, ambient operating conditions and engine-to-engine variability. Given both the wide array of products on which engines are placed and the variety of environmental issues applicable to operating the equipment, the gas engine will not develop the rated gross power when used in a given piece of power equipment (actual “on-site” or net power). This difference is due to a variety of factors including, but not limited to, accessories (air cleaner, exhaust, charging, cooling, carburetor, fuel pump, etc.), application limitations, ambient operating conditions (temperature, humidity, altitude), and engine-to-engine variability. Due to manufacturing and capacity limitations, Briggs & Stratton may substitute an engine of higher rated power for this Series engine.

TRACTOR - - MODEL NO. LTH126 (96041020503), PRODUCT NO. 960 41 02-05
STEERING ASSEMBLY **41**

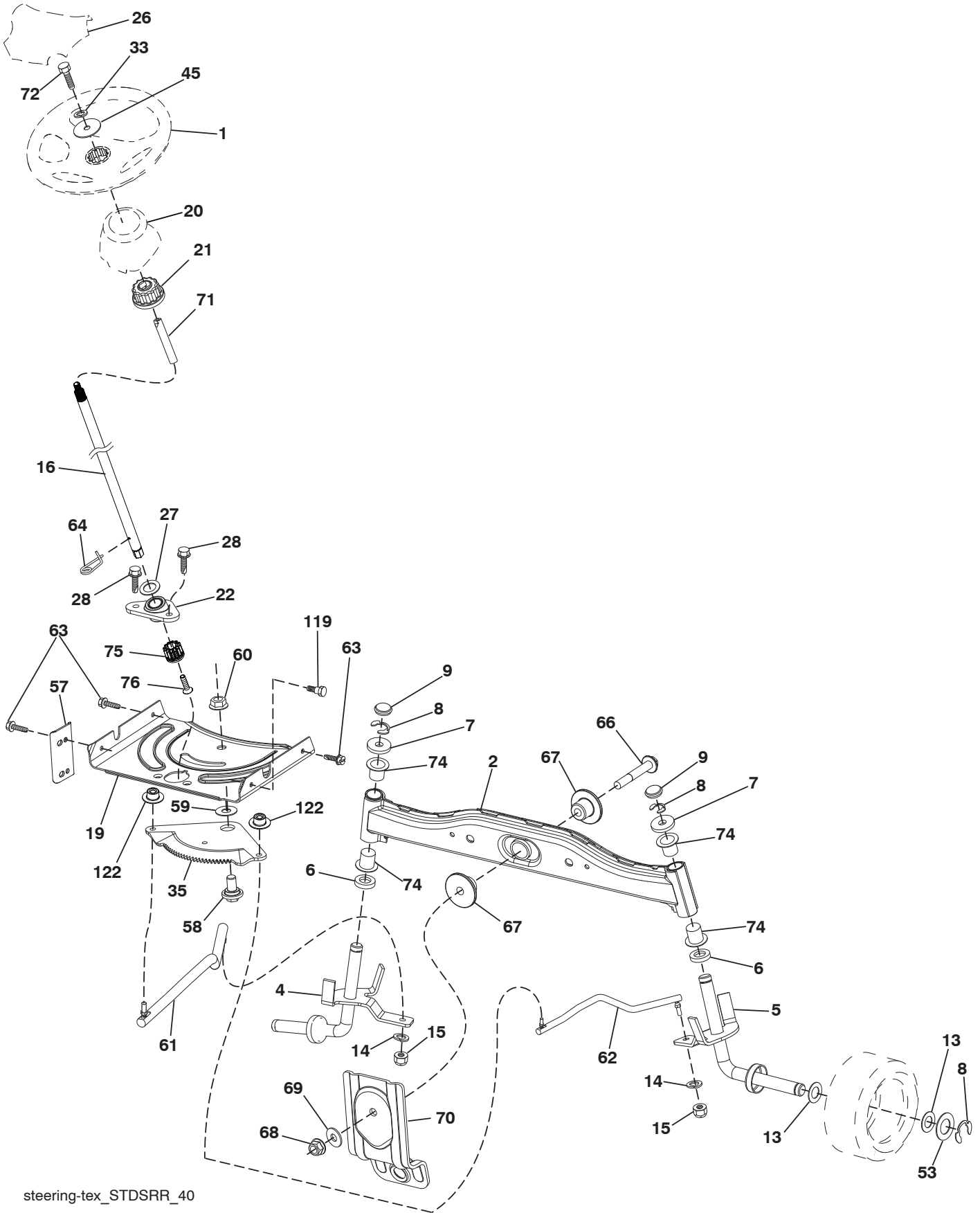

steering-tex_STDSRR_40

**TRACTOR - - MODEL NO. LTH126 (96041020503), PRODUCT NO. 960 41 02-05
STEERING ASSEMBLY **41****

KEY NO.	PART NO.	DESCRIPTION
1	532 43 97-40	Wheel, Steering
2	532 41 81-68	Axle Asm., Front
4	532 41 68-45	Spindle Asm., LH
5	532 41 68-46	Spindle Asm., RH
6	532 12 49-31	Washer Thrust
7	532 12 17-48	Washer 25/32 x 1-5/8 x 16 Ga.
8	812 00 00-29	Ring, Klip #T5304-75
9	532 12 12-32	Cap, Spindle
13	532 12 17-49	Washer 25/32 x 1-1/4 x 16 Ga.
14	810 04 06-00	Washer, Lock Hvy Hlcl Spr 3/8
15	873 54 06-00	Nut, Crown Lock 3/8-24 unf
16	585 86 92-02	Steering Shaft
19	532 19 47-29	Plate Steering
20	532 44 14-25	Boot, Steering
21	532 18 67-37	Adapter, Wheel Steering
22	585 02 98-02	Bearing Shaft
26	532 43 97-43	Insert, Wheel Steering
27	819 21 16-16	Washer 21/32 x 1 x 16 Ga.
28	817 00 06-12	Screw 3/8-16 x 3/4
33	810 04 05-00	Washer Lock 5/16
35	532 19 47-32	Gear, Sector Plate
45	819 11 38-12	Washer 11/32 ID x 2 x 3/8 OD x 12 Ga.
53	532 18 89-67	Washer Hardened .793 x 1.637 x .060
57	532 40 74-65	Bracket Upstop
58	532 19 47-47	Bolt Shoulder Sector Pivot CFM
59	532 19 47-48	Washer Thrust Sector Steering
60	873 97 10-00	Nut Flange Lock 5/8-11
61	532 19 47-40	Draglink, LH
62	532 19 47-41	Draglink, RH
63	817 00 05-12	Screw 5/16-18 x 3/4
64	532 19 98-49	Retainer Clip Spring Steering
66	871 02 07-48	Bolt Hex Fghd 7/16-14 x 3 Serr
67	532 19 47-37	Bushing PM Front Axle
68	873 90 07-00	Nut Lock Flange 7/16-14 Gr. 5
69	532 19 91-62	Washer 1.5 x .505 x .118
70	532 41 70-65	Bracket Deck Susp. Front
71	532 19 07-52	Shaft Extension Steering
72	532 42 89-82	Bolt Fin Hx 5/16-18 x 4
74	532 12 49-37	Bearing
75	580 68 37-01	Pinion
76	580 68 36-01	Screw Head Sock
119	532 17 01-65	Bolt Shoulder 5/16-18
122	532 44 49-62	Cap Gear

NOTE: All component dimensions given in U.S. inches
1 inch = 25.4 mm

TRACTOR - - MODEL NO. LTH126 (96041020503), PRODUCT NO. 960 41 02-05
MOWER DECK 44

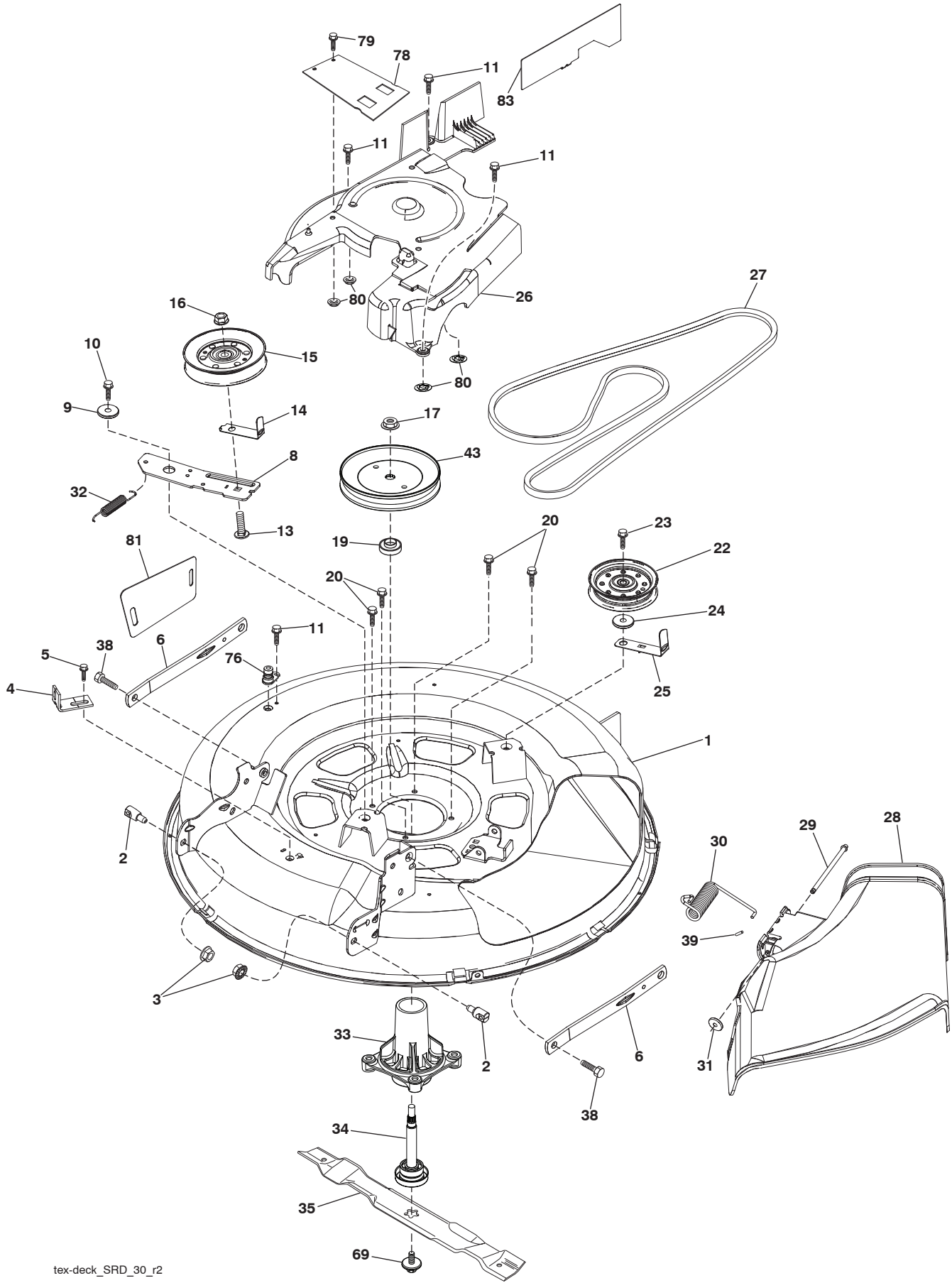

tex-deck_SRD_30_r2

**TRACTOR - - MODEL NO. LTH126 (96041020503), PRODUCT NO. 960 41 02-05
MOWER DECK 44**

KEY NO.	PART NO.	DESCRIPTION	KEY NO.	PART NO.	DESCRIPTION
1	532 44 20-48	Deck Weldment 30"Srd	30	532 19 70-26	Spring Torsion Dfl 38/42/46 Gr
2	532 19 51-61	Stud Fastner w/'D'anti-Rotatio	31	532 11 04-52	Nut Push Phos & Oil
3	873 90 05-00	Nut Lock Hex Flange 5/16 - 18	32	532 19 72-51	Spring Mower Drive Electric
4	532 41 76-45	Bracket Clutch Cable	33	532 18 72-81	Housing Mandrel 4pt Service
5	817 00 05-10	Bolt 5/16-18	34	587 25 65-01	Shaft Asm Mndrl N/Greaseable38
6	532 41 88-63	Arm Susp Mower Rear Srd	35	532 41 92-73	Blade Mower Hp/Mulch Srd
8	532 42 02-52	Arm Idler 30"Srd	38	532 19 65-39	Bolt Shoulder
9	532 19 90-92	Spacer Retainer	39	532 10 53-04	Cap Sleeve
10	817 00 06-16	Screw 3/8 - 16 X 1 Smgml Tap/R Blk	43	532 41 68-77	Pulley Mandrel 6 5 Pd 30"
11	532 13 77-29	Screw Thd Roll 1/4 - 20 X 5/8	69	584 30 93-01	Screw 7/16-20 x 1 Hx
13	872 11 06-12	Bolt Carr Sh 3/8 - 16 X 1 - 1/2 Gr5	76	532 41 55-98	Washout Port
14	532 15 60-85	Keeper Belt Idler	78	532 42 25-66	Guard Deck Arm Clutch
15	532 14 67-63	Pulley Idler V-Groove Dim 4.25	79	532 14 24-32	Screw Hex Wsh Hi-Lo 1/4 x 1/2 unc
16	873 90 06-00	Nut Lock FIG 3/8 - 16 unc	80	532 42 30-62	Pal Nut 1/4
17	532 40 02-34	Nut Flange Lock Top	81	532 42 53-67	Shield Assy Suspension
19	585 32 39-01	Bearing Ball Mandrel	83	532 43 24-67	Assy Shield LH
20	532 17 39-84	Screw Thd Roll Dod Pt Hex	--	587 25 33-01	Mandrel Assembly (Includes Housing (key#14), Shaft Assembly (key#13), And Bearing Only (key#15) - Pulley/Nut/Washer And Blade Bolt/Washers Not Included)
22	532 17 58-20	Pulley Idler Flat Unplated	--	532 43 81-35	Replacement Mower Complete
23	817 49 06-28	Screw Thdrol 3/8 - 16 X 1-3/4			
24	819 13 20-12	Washer 13/32 X 1 - 1/4 X 12 Ga			
25	532 42 02-53	Keeper Belt 30"Srd			
26	532 42 02-55	Cover Mandrel Mwr			
27	532 41 92-71	V-Belt Drive			
28	532 41 73-44	Shield Asm Deflect Mwr 30s Blk			
29	532 42 08-95	Pin Hinge 30			

NOTE: All component dimensions given in U.S. inches
1 inch = 25.4 mm

TRACTOR - - MODEL NO. LTH126 (96041020503), PRODUCT NO. 960 41 02-05
MOWER LIFT 45

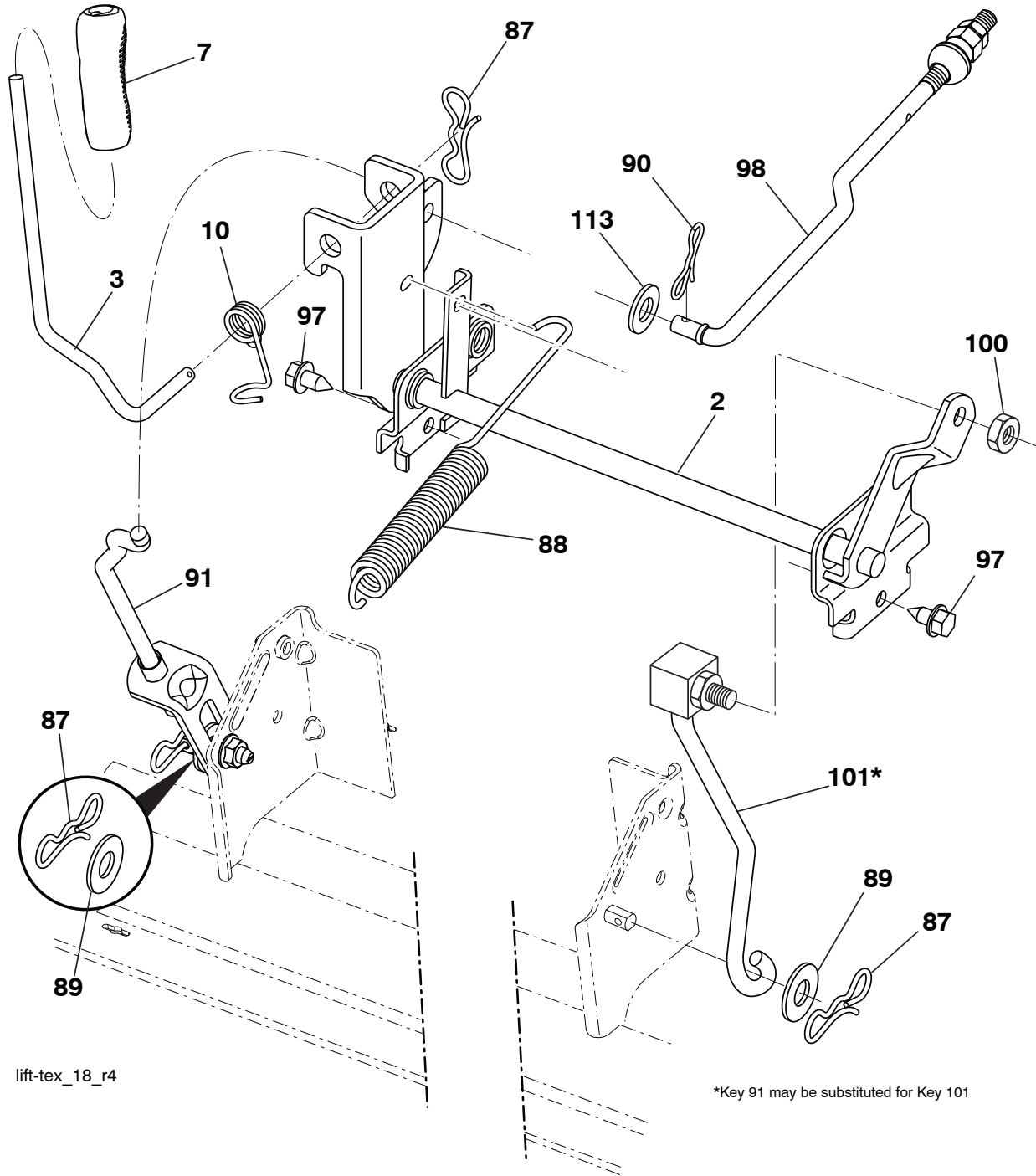

lift-tex_18_r4

*Key 91 may be substituted for Key 101

KEY NO.	PART NO.	DESCRIPTION
2	532 42 20-27	Shaft Asm., Lift
3	532 19 52-31	Lever Asm., Lift RH
7	580 96 23-01	Grip,
10	532 19 63-14	Spring Torsion
87	532 19 42-09	Pin Cotter 7/16 Bow Tie Lock
88	532 41 07-10	Spring Lift Assist
89	819 19 19-12	Washer Clear Zinc
90	532 19 42-08	Pin Cotter 5/16 Bow Tie Lock
91	532 19 51-81	Link Asm Lift LH Rear

KEY NO.	PART NO.	DESCRIPTION
97	817 00 06-12	Screw Hex Wsh. THDR 3/8-16 x 3/4
98	532 19 52-64	Link Lift Susp. Front Mower
100	873 93 06-00	Nut Centerlock 3/8-16 unc
101	532 40 70-03	Link Asm Lift FXD
113	819 17 19-12	Washer 17/32 x 1-3/16 x 12 Ga.

NOTE: All component dimensions given in U.S. inches
 1 inch = 25.4 mm

**TRACTOR - - MODEL NO. LTH126 (96041020503), PRODUCT NO. 960 41 02-05
SEAT ASSEMBLY 42**

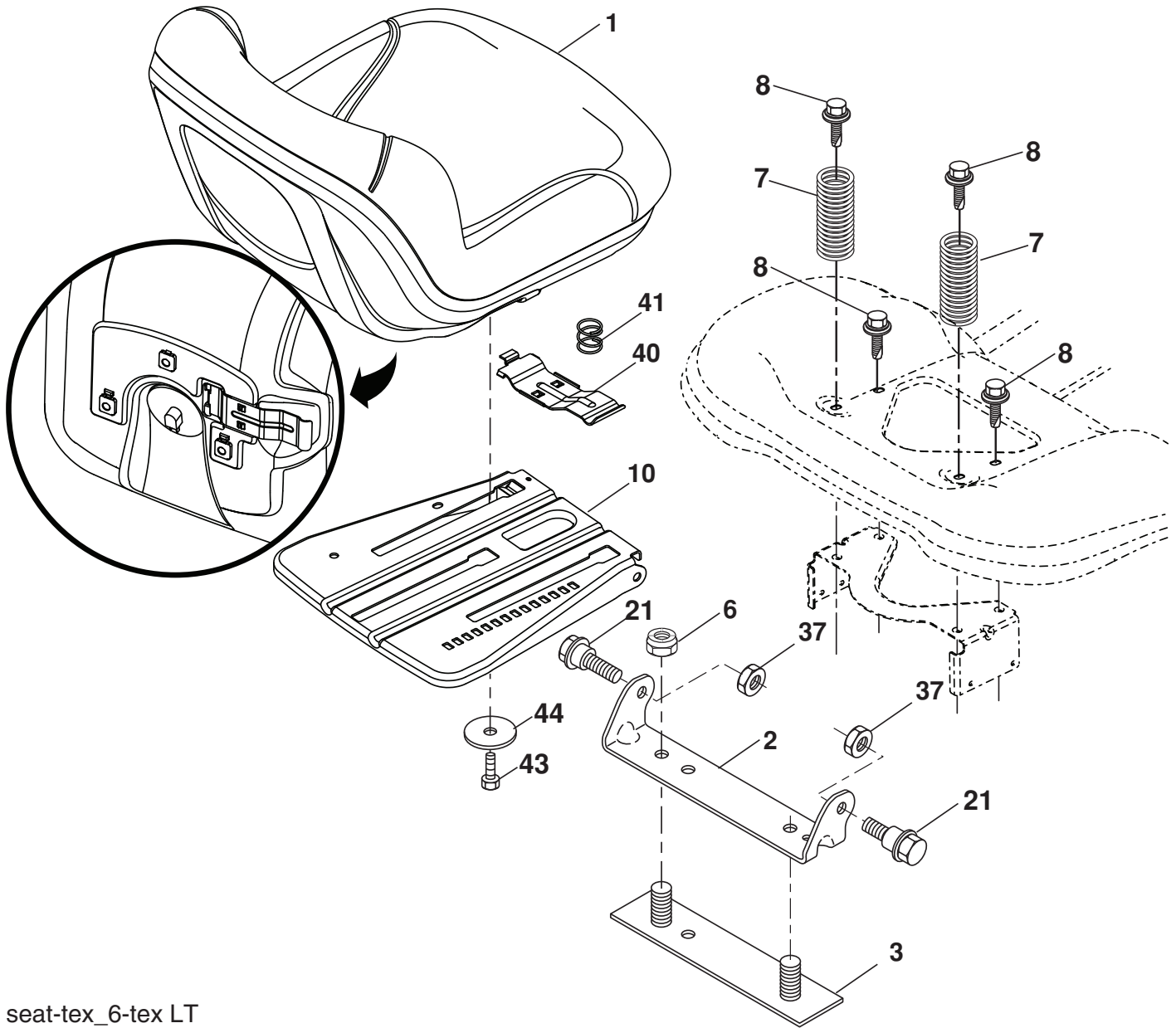

seat-tex_6-tex LT

KEY NO.	PART NO.	DESCRIPTION
1	532 43 98-19	Seat
2	532 18 01-66	Bracket Pivot Fender
3	532 14 06-75	Strap, Asm Fender
6	873 80 06-00	Nut, Lock w/Ins. 3/8-16 unc
7	532 12 41-81	Spring, Seat Cprsn
8	532 17 18-77	Bolt 5/16-18 unc x 3/4 w/Sems
10	532 19 69-77	Pan, Seat
21	532 17 18-52	Bolt, Shoulder 5/16-18

KEY NO.	PART NO.	DESCRIPTION
37	873 80 05-00	Nut, Lock 5/16-18 unc
40	532 19 76-61	Handle Slide Seat
41	532 19 82-00	Spring Latch Seat
43	874 76 06-12	Bolt Fin Hex 3/8-16 unc x 3/4
44	819 13 38-12	Washer 13/32 x 2-3/8 x 12 Ga.

NOTE: All component dimensions given in U.S. inches
1 inch = 25.4 mm

