

ILLUSTRATED PARTS LIST

MFG. ID NO. 96041027201/02

CUSTOMER CATALOG NO. YTH2246TDR

PRODUCT NO. 960 41 02-72

**TRACTOR - - MODEL NO. YTH2246TDR (96041027201/02), PRODUCT NO. 960 41 02-72
DECALS 27**

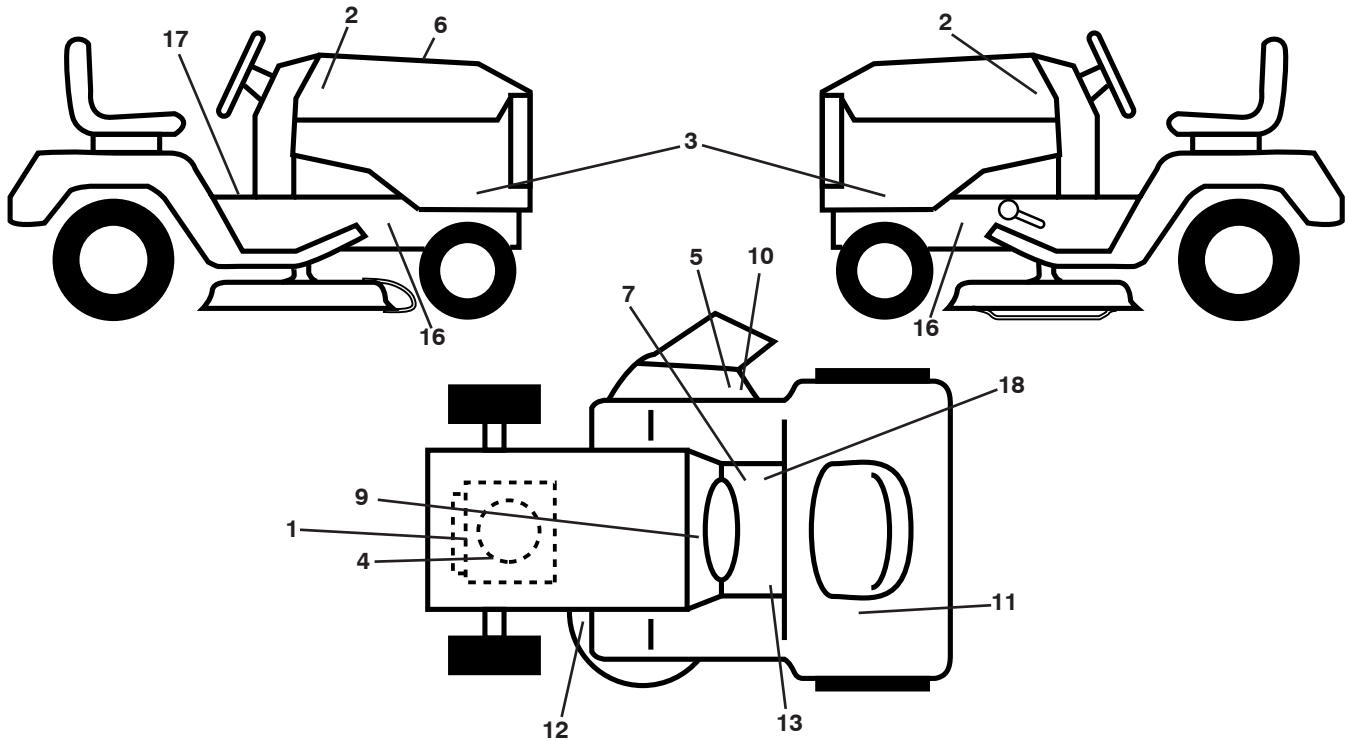

KEY NO.	PART NO.	DESCRIPTION	KEY NO.	PART NO.	DESCRIPTION
1	532 43 29-14	Decal, Engine	13	581 57 81-01	Decal, Warning Symbols
2	581 62 73-01	Decal, Badge	16	581 57 96-01	Decal, Chassis
3	532 44 40-40	Decal, Panel SD	17	581 57 80-01	Decal, Saddle Brake
4	581 57 97-01	Decal, Eng. HP	18	581 57 86-01	Decal, Oper. Cruise
5	584 90 46-01	Decal, Deck/Deflect. Warning	--	581 72 46-01	Decal, Drawbar
6	532 44 38-37	Decal, Replacement	--	581 72 48-01	Decal, Bypass
7	581 72 40-01	Decal, Brake/Clutch	--	532 43 98-82	Pad, Footrest, LH
9	532 14 50-05	Decal, Battery Dnge/Poi	--	532 43 98-81	Pad, Footrest, RH
10	581 57 92-01	Decal, Defl.	--	583 91 59-28	Manual, Operator's (English)
11	581 72 42-01	Decal, Warn. Fuel Reserve			
12	581 58 00-01	Decal, Mower V-Belt Schematic			

WHEELS AND TIRES

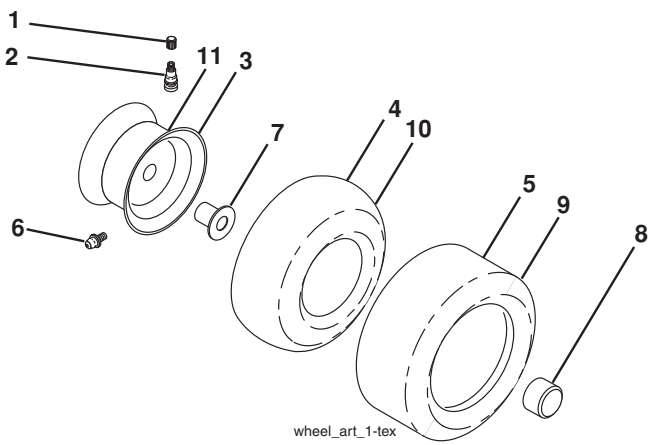

KEY NO.	PART NO.	DESCRIPTION
1	532 05 91-92	Cap Valve Tire
2	532 06 51-39	Stem Valve
3	532 13 83-36	Rim Front Service
4	532 05 99-04	Tube Front (Service Item Only)
5	532 10 62-22	Tire Front
6	532 12 49-57	Fitting Grease (Front Wheel Only)
7	532 12 49-59	Bearing Flange (Front Wheel Only)
8	532 17 50-39	Cap Axle Blk 1 50 x 1 00
9	532 12 20-82	Tire Rear
10	532 12 49-26	Tube Rear (Service Item Only)
11	532 13 83-37	Rim Asm 8" rear Service
--	532 14 43-34	Sealant, Tire (10 oz. Tube)

NOTE: All component dimensions given in U.S. inches
1 inch = 25.4 mm

TRACTOR - - MODEL NO. YTH2246TDR (96041027201/02), PRODUCT NO. 960 41 02-72

SCHEMATIC **38**

SCH13

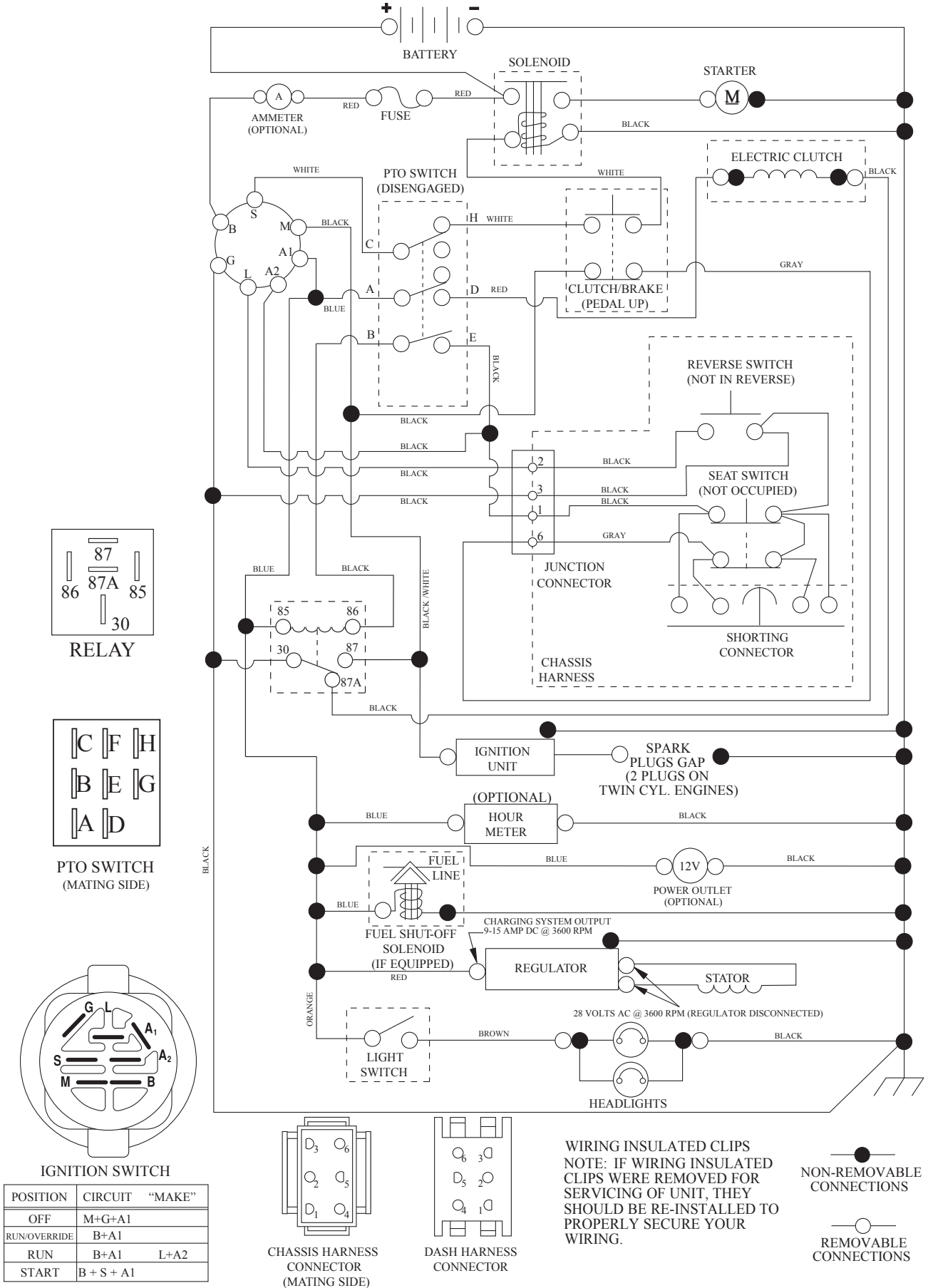

TRACTOR - - MODEL NO. YTH2246TDR (96041027201/02), PRODUCT NO. 960 41 02-72
ELECTRICAL 32

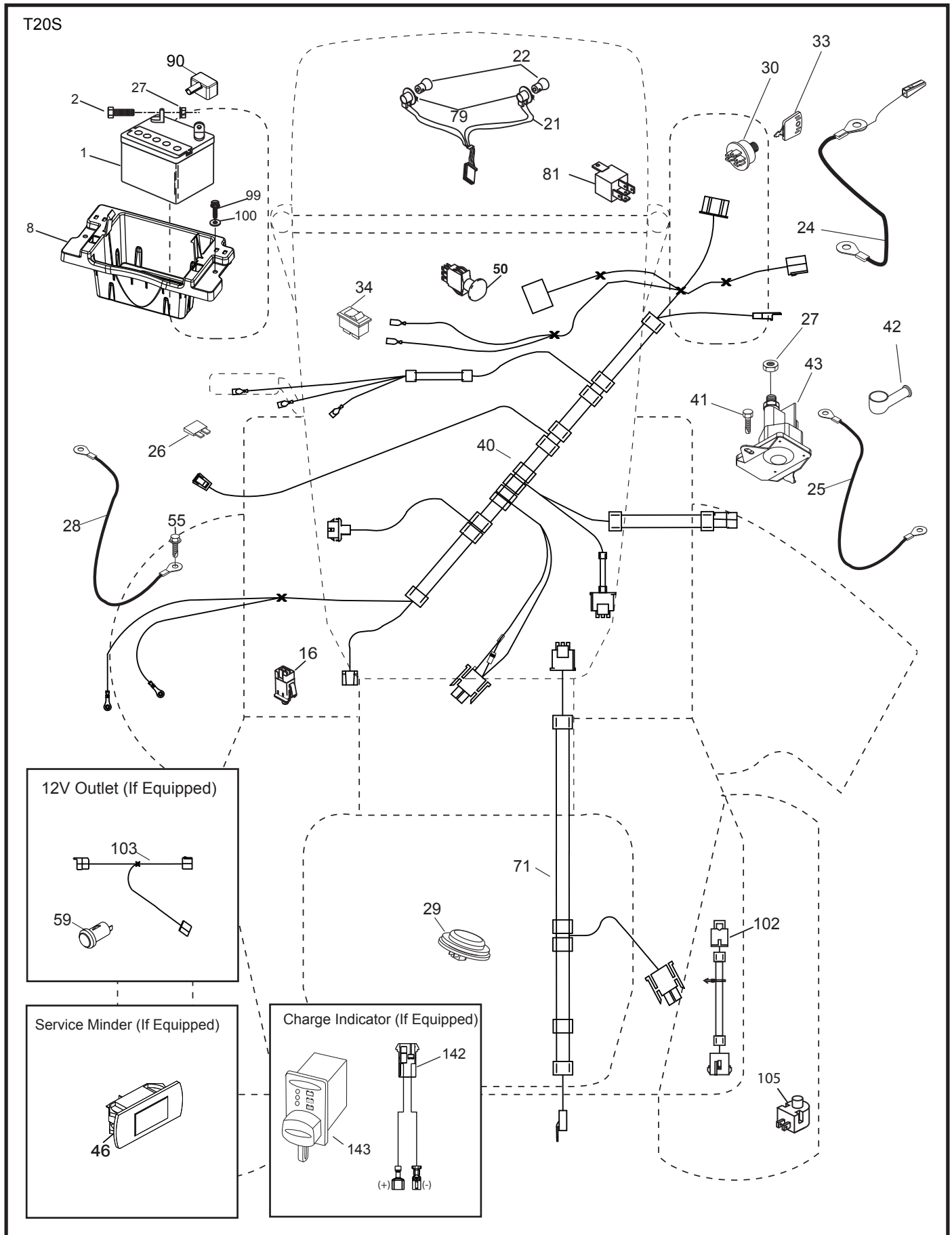

**TRACTOR - - MODEL NO. YTH2246TDR (96041027201/02), PRODUCT NO. 960 41 02-72
ELECTRICAL 32**

KEY NO.	PART NO.	DESCRIPTION
1	532 16 34-65	Battery
2	874 76 04-12	Bolt Hex Head 1/4-20 x 3/4
8	587 20 51-01	Box Battery
16	532 17 61-38	Switch Interlock Push-In
21	532 40 02-52	Harness Socket Light w/4152J
22	532 00 41-52	Bulb Light
24	585 55 56-01	Cable Battery
25	585 55 55-01	Cable Starter
26	532 17 51-58	Fuse
27	873 51 04-00	Nut Keps Hex 1/4-20 unc
28	532 41 65-88	Cable, Ground
29	532 40 15-45	Switch, Seat
30	532 19 33-50	Switch, Ign
33	532 41 19-33	Key\Chain
34	532 11 07-12	Switch Light / Reset
40	581 02 28-01	Harness Ign. Dash
41	817 72 04-08	Screw Thd Cut 1/4-20 x 1/2
42	532 13 15-63	Cover, Terminal
43	532 19 25-07	Solenoid
46	532 40 17-63	Gauge Servicere minder Hrmtr
50	532 17 46-51	Switch PTO
55	817 06 05-12	Screw Thdrol 5/16-18 x 3/4 TYTT
59	532 40 03-03	Outlet 12-Volt
71	532 19 42-76	Harness Ign. Chassis
79	532 17 52-42	Socket Asm Bulb Twistlock
81	532 40 96-15	Relay Harness Sealed
90	532 43 53-95	Cover Terminal
99	817 67 04-12	Screw Hexwsh Thdrol 1/4-20 x 3/4
100	819 09 14-16	Washer 9/32 x 7/8 x 16 Ga.
102	532 40 44-54	Harness Pigtail
103	532 40 79-62	Harness Pigtail 12-Volt
105	532 40 75-68	Switch Reverse TT Pedal Control
142	583 85 78-01	Charge Port Pigtail
143	532 44 80-59	Indicator Battery

NOTE: All component dimensions given in U.S. inches
1 inch = 25.4 mm

TRACTOR - - MODEL NO. YTH2246TDR (96041027201/02), PRODUCT NO. 960 41 02-72
CHASSIS AND ENCLOSURES **39**

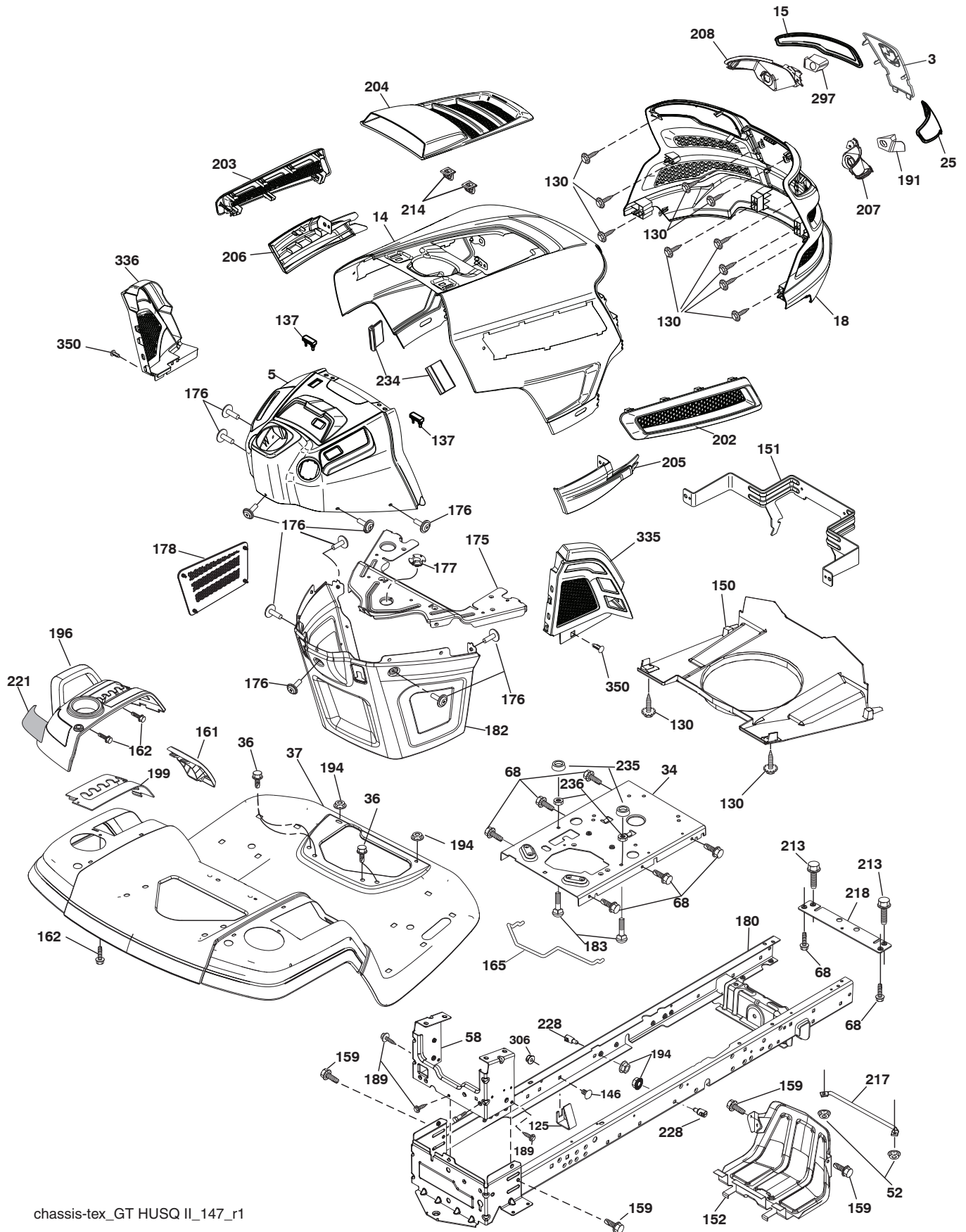

chassis-tex_GT HUSQ II_147_r1

**TRACTOR - - MODEL NO. YTH2246TDR (96041027201/02), PRODUCT NO. 960 41 02-72
CHASSIS AND ENCLOSURES 39**

KEY NO.	PART NO.	DESCRIPTION	KEY NO.	PART NO.	DESCRIPTION
3	532 43 97-52	Applique	191	532 43 74-55	Insert Reflective LH
5	532 43 74-86	Dash	194	873 90 05-00	Nut Lock Hex Flange 5/16-18
14	532 44 11-77	Hood	196	532 43 96-74	Console Asm Decklift
15	532 43 97-33	Lens LH	199	532 19 82-59	Plate Deck Lift
18	532 43 77-62	Grille	202	532 43 97-28	Vent Side Hood RH
25	532 44 33-85	Lens RH	203	532 43 97-27	Vent Side Hood LH
34	580 91 08-01	Plate Engine	204	532 43 57-14	Vent Top Hood
36	817 06 05-12	Screw 5/16-18 x 3/4	205	532 43 97-30	Skirt Hood Side RH
37	532 44 12-08	Fender	206	532 43 97-29	Skirt Hood Side LH
52	873 68 05-00	Nut Lock 5/16-18	207	532 43 97-34	Bezel RH
58	532 41 22-81	Drawbar Upper	208	532 43 97-35	Bezel LH
68	817 49 05-08	Screw Thdrol 5/16-18 x 1/2	213	874 76 05-12	Bolt 5/16-18 x 3/4
125	581 68 48-01	Clip Fuel Line	214	532 19 91-45	Clip Retainer Tinner
130	532 41 63-58	Screw 10 x .750 BOS Thread	217	532 40 91-67	Rod Pivot
137	532 40 75-90	Bumper Dash	218	532 19 63-95	X-Piece Hood Stop
146	581 85 79-01	Bolt	221	532 19 89-09	Reflective LH
150	532 43 97-74	Air Duct	228	532 19 51-61	Stud Fastner
151	532 43 66-70	Bracket Pivot Hood	234	532 40 47-42	Bumper Hood
152	532 43-98-70	Shield Browning	235	532 40 61-29	Spacer Fender
159	817 00 06-12	Screw Hexwsh Thdr 3/8-16 x 3/4	236	873 93 05-00	Nut Lock 5/16-18 unc
161	532 43 99-29	Window, Fuel	297	532 43 74-56	Insert Reflective RH
162	532 14 24-32	Screw Hex Wsh 1/4 x 1/2 unc	306	873 90 06-00	Nut Lock
165	532 19 68-26	Support Tank Rear	335	532 44 82-04	Cover RH Close Out
175	532 19 63-04	Crossmember	336	532 44 53-09	Cover LH Close Out
176	532 40 07-76	Screw 10-24 x 5/8	350	532 44 51-43	Clip X-mas Tree
177	532 19 52-28	Bushing Steering	--	532 43 18-83	Kit Bumper
178	532 19 97-82	Cargo Net Asm.			
180	532 41 50-64	Chassis			
182	532 40 68-59	Dash Lower			
183	874 52 05-20	Bolt 5/16-18 x 1-1/4 Full Thd.			
189	817 00 05-12	Screw 5/16-18 x 3/4			

NOTE: All component dimensions given in U.S. inches
1 inch = 25.4 mm

**TRACTOR - - MODEL NO. YTH2246TDR (96041027201/02), PRODUCT NO. 960 41 02-72
DRIVE **40****

KEY NO.	PART NO.	DESCRIPTION	KEY NO.	PART NO.	DESCRIPTION
1	---	Transaxle, TUFFTORQ K46CR (501051401) (Order parts from transaxle manufacturer.)	184	532 44 14-55	Handle Parking Brake
2	532 12 35-83	Key	185	872 11 06-22	Bolt Rdhd Sqnk 3/8-16 x 2-3/4 Gr. 5
15	819 13 13-16	Washer 13/32 x 13/16 x 16 Ga.	186	532 19 43-21	Spacer Retainer
17	532 41 36-78	Spring, Brake	187	819 13 32-10	Washer
26	532 19 96-79	Spring Return Cruise	188	532 19 43-23	Link Clutch Ground Drive
29	532 40 38-06	Rod, Brake	189	532 19 43-17	Bellcrank Ground Drive
33	812 00 00-01	Ring E	190	532 19 43-18	Keeper Bellcrank Ground Drive
35	583 86 45-01	Rod, Brake, Park	196	817 00 06-16	Screw 3/8-16 x 1
42	532 12 48-72	Cover, Foot Pedal	197	585 65 86-01	Link Clutch Anti-Rotation
49	872 11 06-14	Bolt	205	532 12 17-48	Washer
50	532 19 43-27	Pulley Idler Flat	206	532 44 85-96	Bracket Mount Latch Cruise
51	873 90 06-00	Lock Nut 3/8-16	207	532 19 78-68	Latch Control Cruise
52	532 19 43-26	Idler V-Groove	208	532 19 78-69	Gear Sector Control Cruise
56	532 13 09-69	V-Belt, Drive	209	532 19 95-92	Rod Control Cruise
64	532 19 78-65	Shaft Asm. Pedal Brake Control	210	532 19 78-60	Rocker Asm. Pedal Control
70	532 43 96-61	Console Asm	211	532 12 01-83	Bearing Nylon
73	874 49 05-40	Bolt Hex 5/16-18 x 2. 1/2 Gr. 5	213	532 40 31-19	Knob Control Cruise
74	532 14 24-32	Screw Hex 1/4 x 1/2 unc	214	532 41 68-63	Pedal Forward
92	874 76 05-20	Bolt Fin Hex 5/16-18 unc x 1.25	215	532 40 17-23	Pedal Reverse
99	532 41 57-42	Rod Spring Bypass	216	532 19 61-31	Bracket Pulley Idler
116	873 90 05-00	Nut Lock Hex Flange 5/16-18	220	532 19 89-08	Reflector RH
125	817 00 05-12	Screw 5/16-18 x 3/4	221	532 40 31-87	Retainer Spring Clip Handle
143	817 49 05-08	Screw 5/16-18 x 1/2	222	879 21 20-10	Washer 21/32 x 1-1/4 x 10 Ga.
153	532 12 47-88	Retainer Spring	225	532 40 33-19	Keeper Belt Trans.
159	876 02 04-12	Pin Cotter 1/8 x 3/4	227	817 49 05-12	Screw 5/16-18 x 3/4
160	532 16 94-84	Retainer Clip	230	532 18 89-67	Washer Hardened
161	532 10 57-09	Spring, Return, Clutch	284	532 41 76-93	Nut U-CHNL 1/4-20
163	532 44 82-75	Rod Pedal Control	307	874 18 04-12	Screw Mach. CR. 1/4-20 x 3/4
166	532 42 91-64	Nut Push	325	585 66 85-02	Torque Strap K46 LT RH
167	532 40 52-57	Latch Brake Parking	326	585 67 08-02	Bracket Trq Stp 46 20" Tire RH
170	532 19 43-22	Keeper Belt Centerspan	336	587 25 96-01	Bolt 5/16-18 x 1-3/4 Flanged
171	872 11 06-16	Bolt RDHD SQNK 3/8-16 unc x 2			
183	532 13 70-57	Spacer Split			

NOTE: All component dimensions given in U.S. inches
1 inch = 25.4 mm

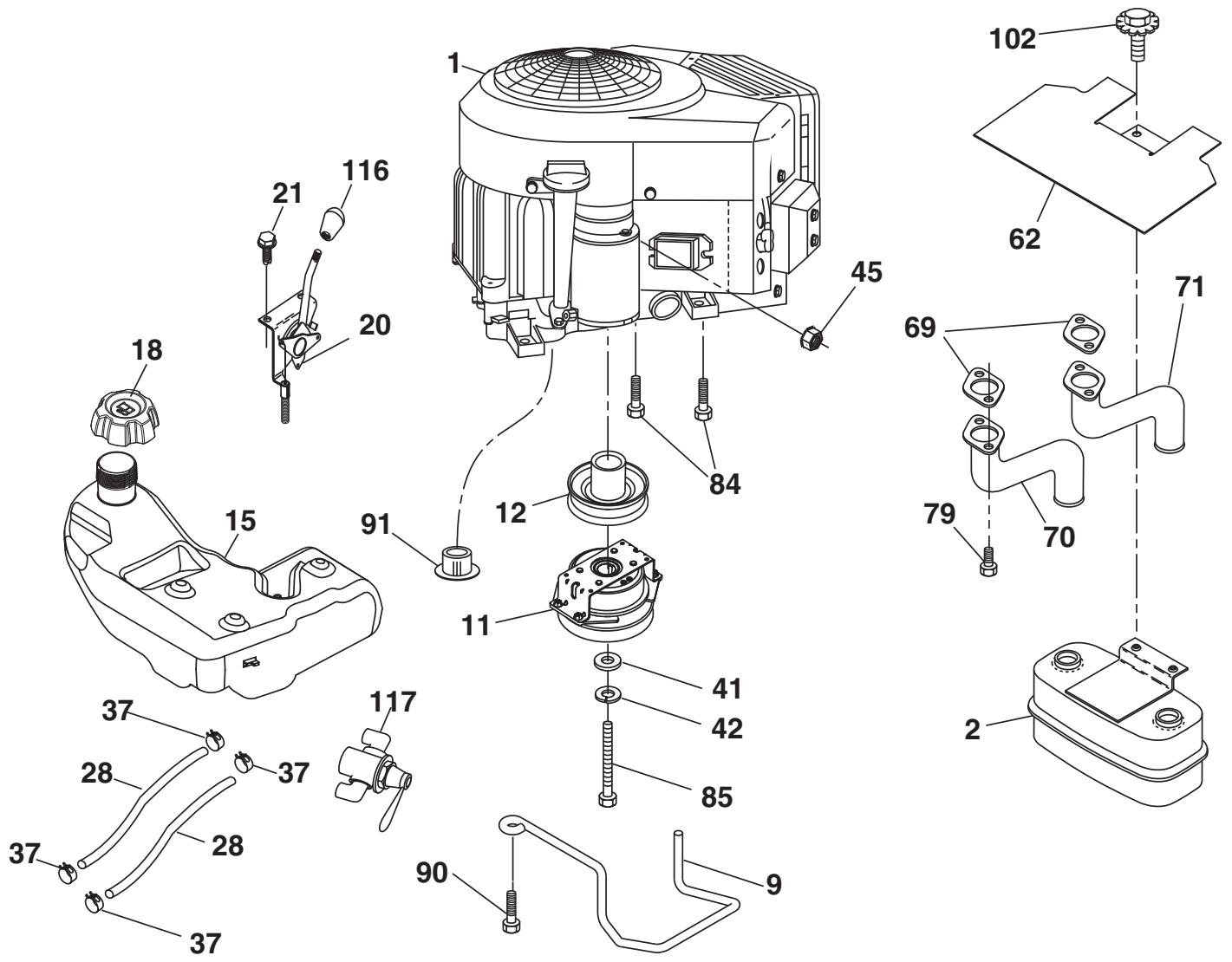

SPARK ARRESTER KIT

engine-tex_bs-2cyl_116_r1

**TRACTOR - - MODEL NO. YTH2246TDR (96041027201/02), PRODUCT NO. 960 41 02-72
ENGINE 24**

KEY NO.	PART NO.	DESCRIPTION
1	---	Engine B&S 40H777-1575-G5 (442152) (Order parts from engine manufacturer.)
2	532 44 59-62	Muffler
9	532 19 43-20	Keeper Belt Engine
11	587 24 16-01	Clutch Electric
12	532 40 50-97	Pulley Engine
15	532 42 28-04	Tank Fuel
18	532 43 96-45	Cap Asm Fuel
20	532 42 43-40	Control Throttle/Choke
21	532 41 63-58	Screw #10 x .750 BOS Thread
28	532 40 11-35	Fuel Line
29	532 13 71-80	Spark Arrester Kit
37	532 12 34-87	Clamp Hose
41	532 12 61-97	Washer 1-1/2 OD x 15/32 ID x .250
42	810 04 07-00	Washer Lock 7/16
45	873 51 04-00	Nut Keps Hex 1/4-20 unc
62	532 43 40-17	Heat Shield
69	532 16 53-91	Gasket
70	581 88 11-01	Exhaust Tube LH
71	581 88 10-01	Exhaust Tube RH
79	532 18 39-06	Screw Socket Head 5/16-18 x 1
84	817 06 06-20	Screw 3/8-16 x 1-1/4
85	532 17 99-53	Bolt 7/16-20 x 3.75 Gr.
90	817 00 06-16	Screw 3/8-16 x 1
91	532 18 74-95	Bushing
102	817 00 05-12	Screw 5/16-18 x 3/4
116	539 13 26-24	Knob Shift
117	532 42 08-28	Valve Fuel Reserve

NOTE: All component dimensions given in U.S. inches
1 inch = 25.4 mm

Engine Power Rating Information

The gross power rating for individual gas engine models is labeled in accordance with SAE (Society of Automotive Engineers) code J1940 (Small Engine Power & Torque Rating Procedure), and rating performance has been obtained and corrected in accordance with SAE J1995 (Revision 2002-05). Torque values are derived at 3060 RPM; horsepower values are derived at 3600 RPM. Actual gross engine power will be lower and is affected by, among other things, ambient operating conditions and engine-to-engine variability. Given both the wide array of products on which engines are placed and the variety of environmental issues applicable to operating the equipment, the gas engine will not develop the rated gross power when used in a given piece of power equipment (actual “on-site” or net power). This difference is due to a variety of factors including, but not limited to, accessories (air cleaner, exhaust, charging, cooling, carburetor, fuel pump, etc.), application limitations, ambient operating conditions (temperature, humidity, altitude), and engine-to-engine variability. Due to manufacturing and capacity limitations, Briggs & Stratton may substitute an engine of higher rated power for this Series engine.

TRACTOR - - MODEL NO. YTH2246TDR (96041027201/02), PRODUCT NO. 960 41 02-72
STEERING ASSEMBLY **41**

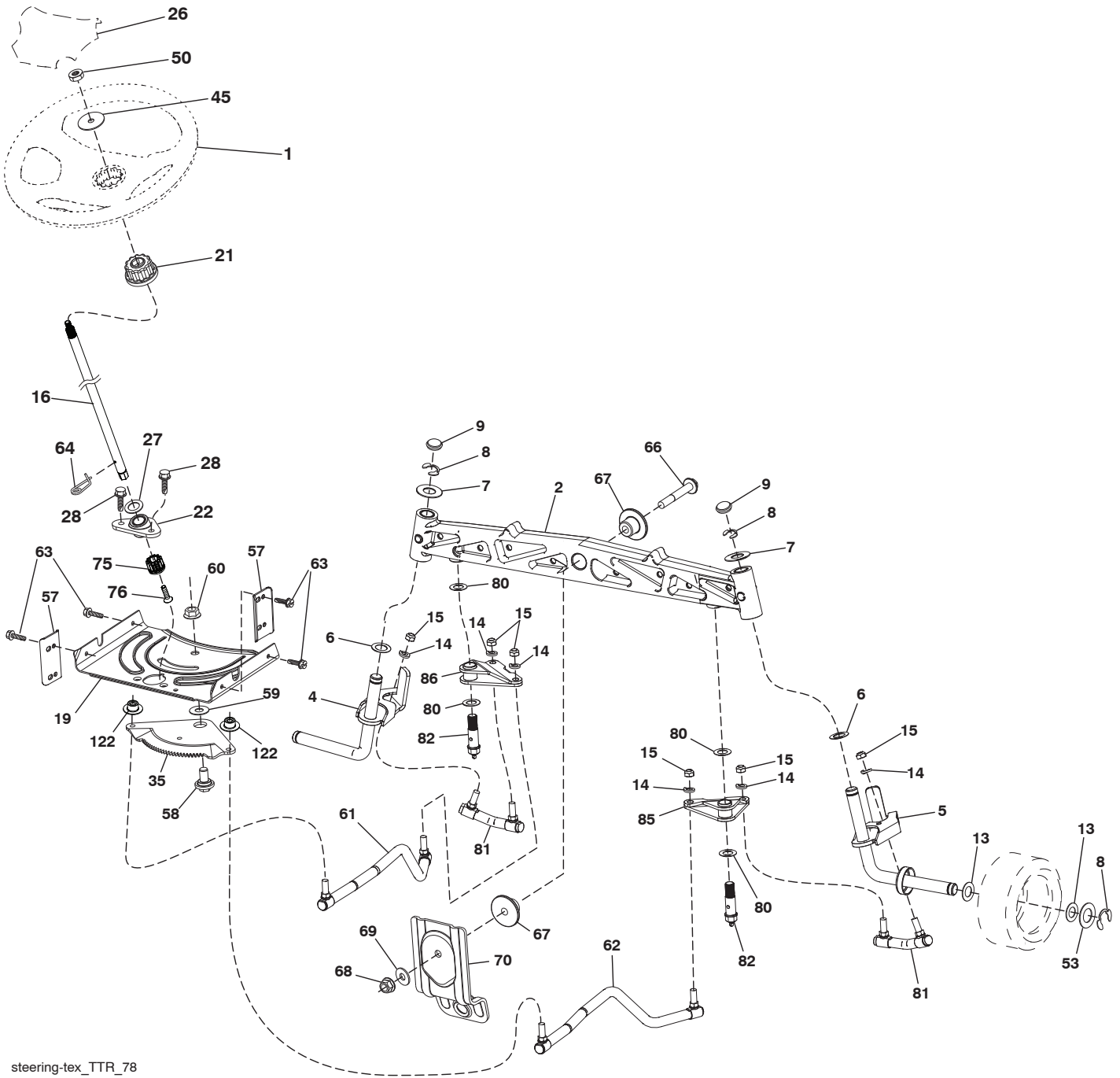

steering-tex_TTR_78

**TRACTOR - - MODEL NO. YTH2246TDR (96041027201/02), PRODUCT NO. 960 41 02-72
STEERING ASSEMBLY 41**

KEY NO.	PART NO.	DESCRIPTION
1	532 43 97-40	Wheel, Steering
2	532 43 68-70	Axle Asm., Front
4	532 43 68-73	Spindle Asm., LH
5	532 43 68-74	Spindle Asm., RH
6	532 12 49-31	Bearing, Race Thrust Harden
7	532 12 17-48	Washer 25/32 x 1-5/8 x 16 Ga.
8	812 00 00-29	Ring, Klip #T5304-75
9	532 12 12-32	Cap, Spindle
13	532 12 17-49	Washer 25/32 x 1-1/4 x 16 Ga.
14	810 04 06-00	Washer, Lock Hvy Hlcl Spr 3/8
15	873 54 06-00	Nut, Crown Lock 3/8-24 unf
16	587 01 60-02	Steering Shaft
19	532 19 47-29	Plate Steering
21	532 43 77-47	Adapter, Wheel Steering
22	585 02 99-01	Bearing Shaft
26	532 43 97-43	Insert, Wheel Steering
27	819 21 16-16	Washer 21/32 x 1 x 16 Ga.
28	817 00 06-12	Screw 3/8-16 x 3/4
35	532 44 07-70	Gear, Sector
45	819 18 38-12	Washer 9/16 ID x 2-3/8 OD 12 Ga.
50	873 90 06-00	Nut Lock Flg 3/8-16 unc
53	532 18 89-67	WasherHardened.793x1.637x.060
57	532 40 74-65	Bracket Upstop
58	532 19 47-47	Bolt Shoulder Sector Pivot CFM
59	532 19 47-48	Washer Thrust Sector Steering
60	873 97 10-00	Nut Flange Lock 5/8-11
61	532 43 68-84	Draglink LH
62	532 43 68-85	Draglink, RH
63	817 00 05-12	Screw 5/16-18 x 3/4
64	532 19 98-49	Retainer Clip Spring Steering
66	871 02 07-48	Bolt Hex Fghd 7/16-14 x 3 Serr
67	532 19 47-37	Bushing PM Front Axle
68	873 90 07-00	Nut Lock Flange 7/16-14 Gr. 5
69	532 19 91-62	Washer 1.5 x .505 x .118
70	532 19 61-97	Bracket Deck Susp. Front
75	580 68 37-01	Pinion
76	580 68 36-01	Screw Head Sock
80	532 00 13-70	Washer Thrust
81	532 43 68-87	Link Cross RH
82	532 43 68-77	Pivot Bolt
85	532 44 18-73	Pivot RH
86	532 44 18-72	Pivot LH
122	532 44 49-62	Cap Gear Sector

NOTE: All component dimensions given in U.S. inches
1 inch = 25.4 mm

**TRACTOR - - MODEL NO. YTH2246TDR (96041027201/02), PRODUCT NO. 960 41 02-72
MOWER DECK **44****

KEY NO.	PART NO.	DESCRIPTION	KEY NO.	PART NO.	DESCRIPTION
1	532 44 23-82	Mower Housing	59	532 14 10-43	Guard, Tuv Idler (94)
2	532 40 55-07	Cover Mandrel LH	62	874 52 06-36	Bolt 3/8-16 unc x 2-1/4 Gr. 5
3	532 40 55-06	Cover Mandrel RH	68	532 40 51-43	V-Belt
4	874 76 05-12	Bolt Hex Hd 5/16-18 unc	69	872 14 05-05	Bolt
6	532 19 51-86	Arm Suspension	116	532 12 48-42	Bolt, Shoulder
11	532 40 53-80	Blade Mower Hi Lift	117	532 18 86-06	Wheel, Gauge
12	584 30 93-01	Screw	118	873 93 06-00	Nut Centerlock 3/8-16 unc
13	587 25 65-01	Shaft Assembly, Mandrel	119	819 12 14-14	Washer 3/8 x 7/8 x 14 Ga.
14	532 18 72-81	Housing, Mandrel	145	532 19 31-97	Pulley Idler
15	585 32 39-01	Bearing, Mandrel	147	532 19 72-51	Spring Return
19	532 19 65-39	Bolt, Shoulder	188	532 19 51-61	Stud Fastener
21	873 68 05-00	Nut	189	873 90 05-00	Nut Lock Hex Flange
23	532 19 25-57	Bracket, Deflector	197	819 13 13-12	Washer 13/32 x 13/16 x 12 Ga.
24	532 10 53-04	Cap, Sleeve	198	532 40 31-49	Baffle Center Front
25	532 19 70-26	Spring, Torsion, Deflector	199	532 40 31-50	Baffle Front RH
26	532 11 04-52	Nut, Push	200	532 41 35-24	Washer 13/32x1x1/2 11 GAHRD
27	532 40 53-57	Shield, Deflector	241	532 15 29-27	Screw
29	532 13 14-91	Rod, Hinge	242	532 41 55-98	Washout Port
30	532 17 39-84	Screw Thdrol Rolling Wsh Hd	--	587 25 33-01	Mandrel Assembly (Includes housing (Key #14), shaft assembly (Key #13), and bearing only (Key #15) - pulley/nut/washer and blade bolt/washers not included)
32	532 19 74-73	Pulley, Mandrel			
33	532 40 02-34	Nut, Toplock, Flanged			
34	872 11 06-12	Bolt Carr Sh. 3/8-16 x 1-1/2 Gr. 5			
36	532 19 73-79	Pulley, Idler, Flat			
38	532 43 25-20	Belt Keeper LH			
40	873 90 06-00	Nut, Lock Flg. 3/8-16 unc	--	532 44 43-80	Replacement Mower, Complete
46	532 13 77-29	Screw Thd Roll 1/4-20 x 5/8			
55	532 19 72-49	Arm, Idler			
56	532 19 90-92	Spacer, Retainer			
57	817 00 06-16	Screw Hexwsh Thd 3/8-16 x 1			

NOTE: All component dimensions given in U.S. inches
1 inch = 25.4 mm

TRACTOR - - MODEL NO. YTH2246TDR (96041027201/02), PRODUCT NO. 960 41 02-72
MOWER LIFT 45

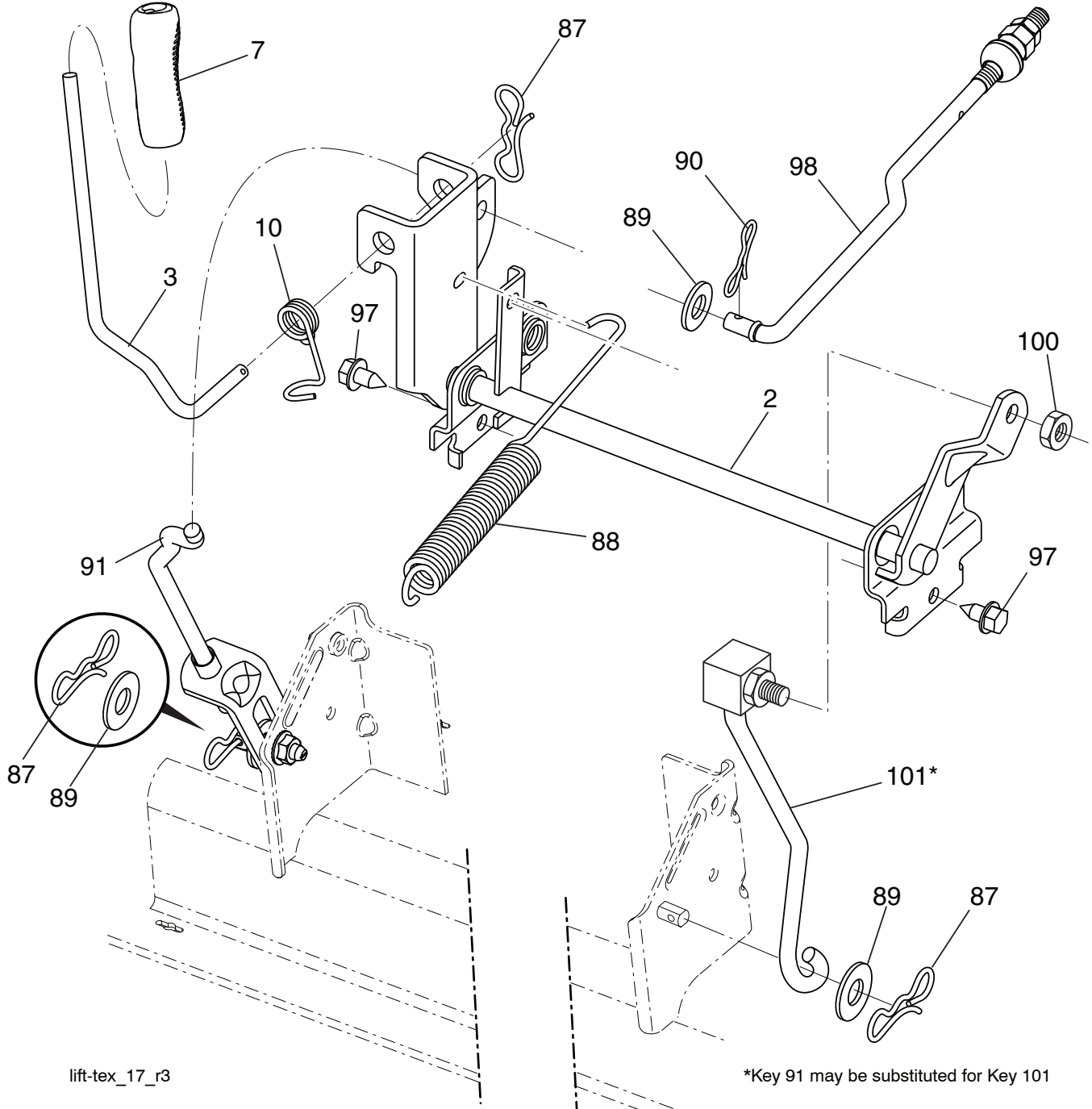

lift-tex_17_r3

KEY NO.	PART NO.	DESCRIPTION
2	532 42 20-27	Shaft Asm., Lift
3	532 19 52-30	Lever Lift Handle
7	580 96 23-01	Grip, Lever
10	532 19 63-14	Spring Torsion
87	532 19 42-09	Pin Cotter 7/16 Bow Tie Lock
88	532 41 07-10	Spring Lift Assist
89	819 19 19-12	Washer Clear Zinc
90	532 19 42-08	Pin Cotter 5/16 Bow Tie Lock
91	532 19 51-81	Link Lift Susp Mower Rear

KEY NO.	PART NO.	DESCRIPTION
97	817 00 06-12	Screw 3/8-16 x 3/4
98	532 19 52-70	Link Asm. Susp. Front Mower
100	873 93 06-00	Nut Centerlock 3/8-16 unc
101	532 40 70-03	Link Lift Asm Fxd

NOTE: All component dimensions given in U.S. inches
 1 inch = 25.4 mm

**TRACTOR - - MODEL NO. YTH2246TDR (96041027201/02), PRODUCT NO. 960 41 02-72
SEAT ASSEMBLY 42**

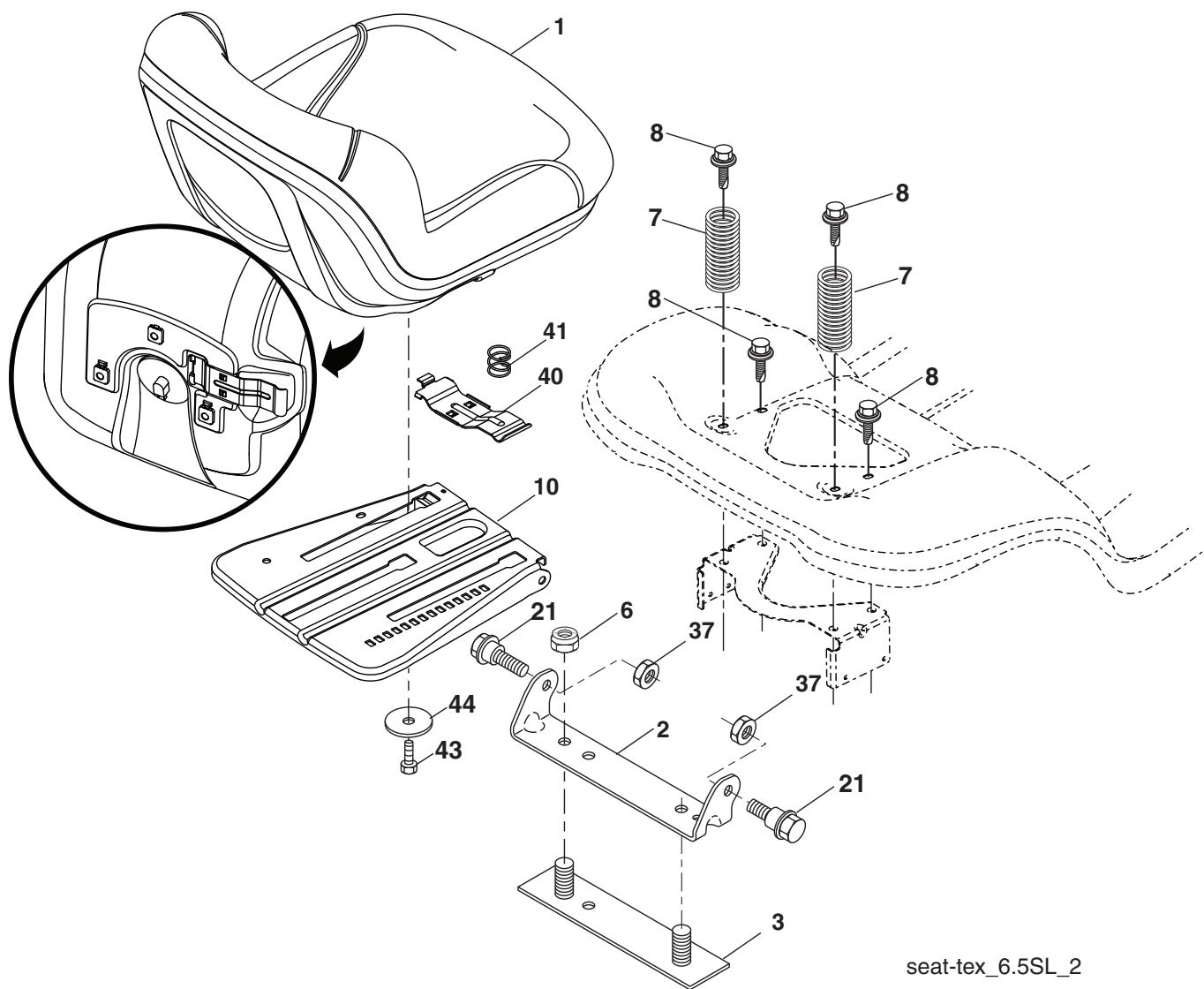

KEY NO.	PART NO.	DESCRIPTION
1	532 43 98-22	Seat
2	532 18 01-66	Bracket Pivot Fender
3	532 14 06-75	Strap, Asm Fender
6	873 80 06-00	Nut, Lock W/Ins. 3/8-16 unc
7	532 12 41-81	Spring, Seat Cprsn
8	532 17 18-77	Bolt 5/16-18 unc x 3/4 w/Sems
10	532 19 69-77	Pan, Seat
21	532 17 18-52	Bolt, Shoulder 5/16-18

KEY NO.	PART NO.	DESCRIPTION
37	873 80 05-00	Nut, Lock 5/16-18 unc
40	532 19 76-61	Handle Slide Seat
41	532 19 82-00	Spring Latch Seat
43	874 76 06-12	Bolt Fin Hex 3/8-16 unc x 3/4
44	819 13 38-12	Washer 13/32 x 2-3/8 x 12 Ga.

NOTE: All component dimensions given in U.S. inches
1 inch = 25.4 mm

