

ILLUSTRATED PARTS LIST

MODEL NO. 96041003009

CUSTOMER CATALOG NO. LTH152

PRODUCT NO. 960 41 00-30

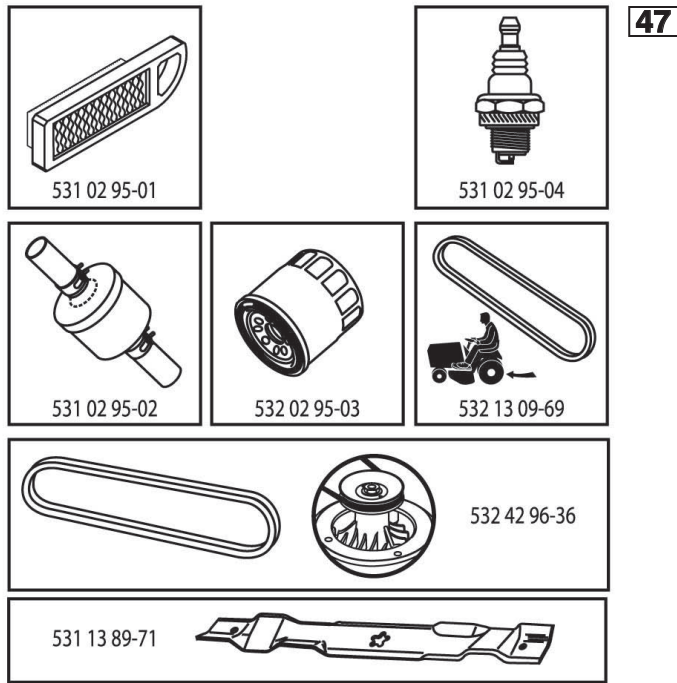

433512

**TRACTOR - - MODEL NO. LTH152 (96041003009), PRODUCT NO. 960 41 00-30
DECALS 27**

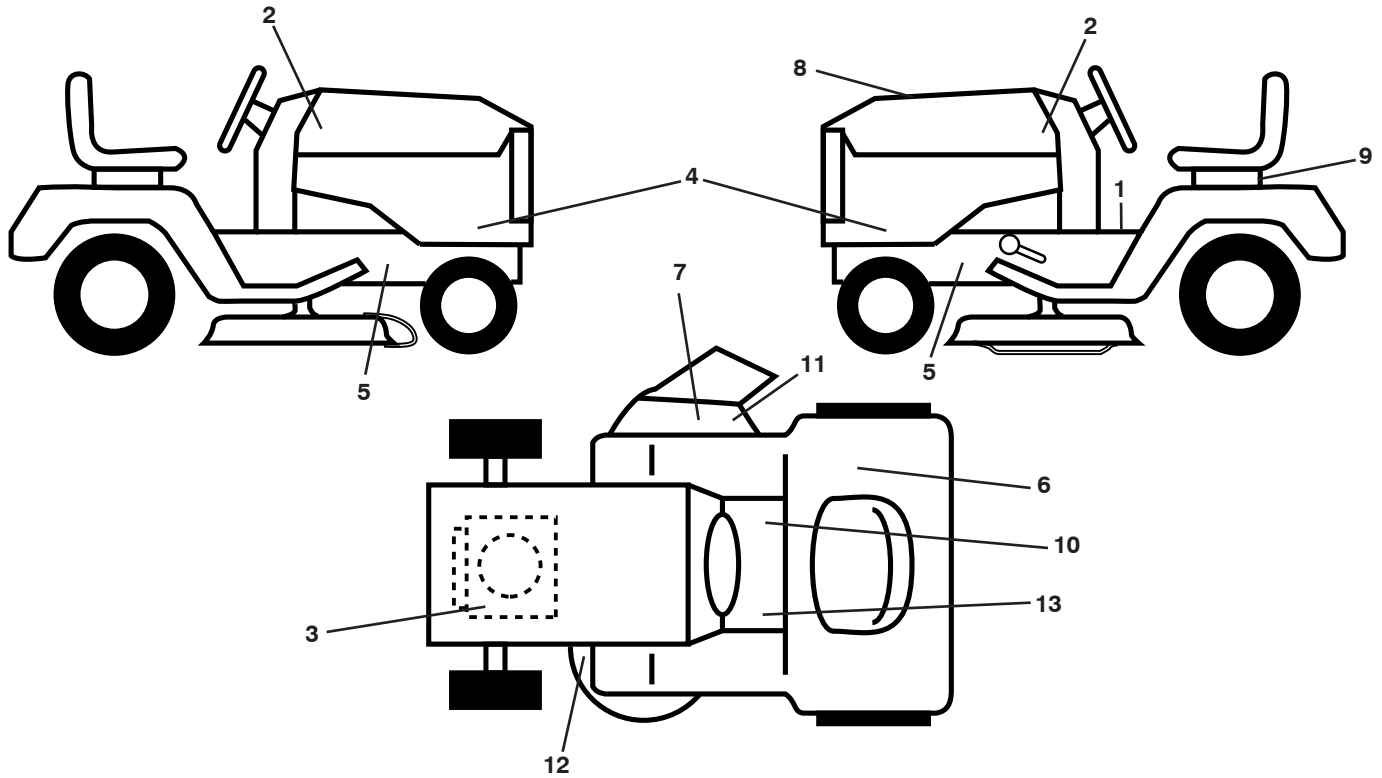

KEY NO.	PART NO.	DESCRIPTION
1	532 40 03-89	Decal, Operators
2	581 62 73-01	Emblem, Hood
3	532 19 68-41	Decal, Warning Eng. Symbols
4	532 43 79-18	Decal, Hood Panel
5	532 15 97-36	Decal, Chassis Hot Muffler
6	532 18 04-32	Decal, Fender 100 DB/CE
7	532 18 21-66	Decal, Cutfinger CE
8	532 43 35-12	Decal, Rpl
9	532 14 50-05	Decal, Battery Dnge/Poi
10	532 14 08-37	Decal, Saddle Brake Parking
11	532 19 63-57	Decal, Warning

KEY NO.	PART NO.	DESCRIPTION
12	532 16 03-96	Decal, Mower V-Belt Schematic
13	532 15 97-37	Decal, Brake/Clutch Symbol
--	532 16 69-60	Decal, Bypass
--	532 43 96-81	Pad, Footrest, LH
--	532 43 99-66	Pad, Footrest, RH
--	532 16 25-98	Decal, Drawbar Load Limit
--	532 43 10-55	Manual Oper. Euro
--	532 43 10-56	Manual Oper. Scand
--	532 43 10-57	Manual Oper. E-Bloc
--	532 43 10-58	Manual Oper. Baltic

WHEELS AND TIRES

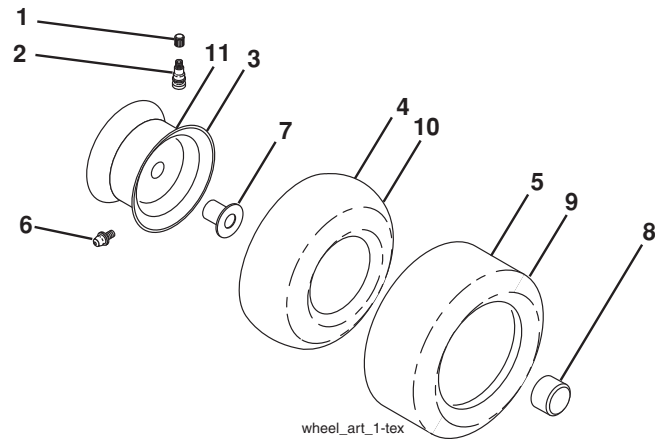

KEY NO.	PART NO.	DESCRIPTION
1	532 05 91-92	Cap Valve Tire
2	532 06 51-39	Stem Valve
3	532 13 83-36	Rim Asm 6" Front
4	532 05 99-04	Tube Front (Service Item Only)
5	532 10 62-22	Tire F T 15 x 6 0 - 6
6	532 12 49-57	Fitting Grease (Front Wheel Only)
7	532 12 49-59	Bearing Flange (Front Wheel Only)
8	532 17 50-39	Cap Axle Blk 1 50 x 1 00
9	532 42 05-31	Tire R 18 x 9.5-8 Turf Saver
10	532 12 49-26	Tube Rear (Service Item Only)
11	532 13 83-37	Rim Asm 8" Rear
--	532 14 43-34	Sealant, Tire (10 oz. Tube)

NOTE: All component dimensions given in U.S. inches
1 inch = 25.4 mm

TRACTOR - - MODEL NO. LTH152 (96041003009), PRODUCT NO. 960 41 00-30 SCHEMATIC **38**

SCH10

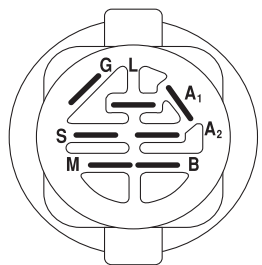
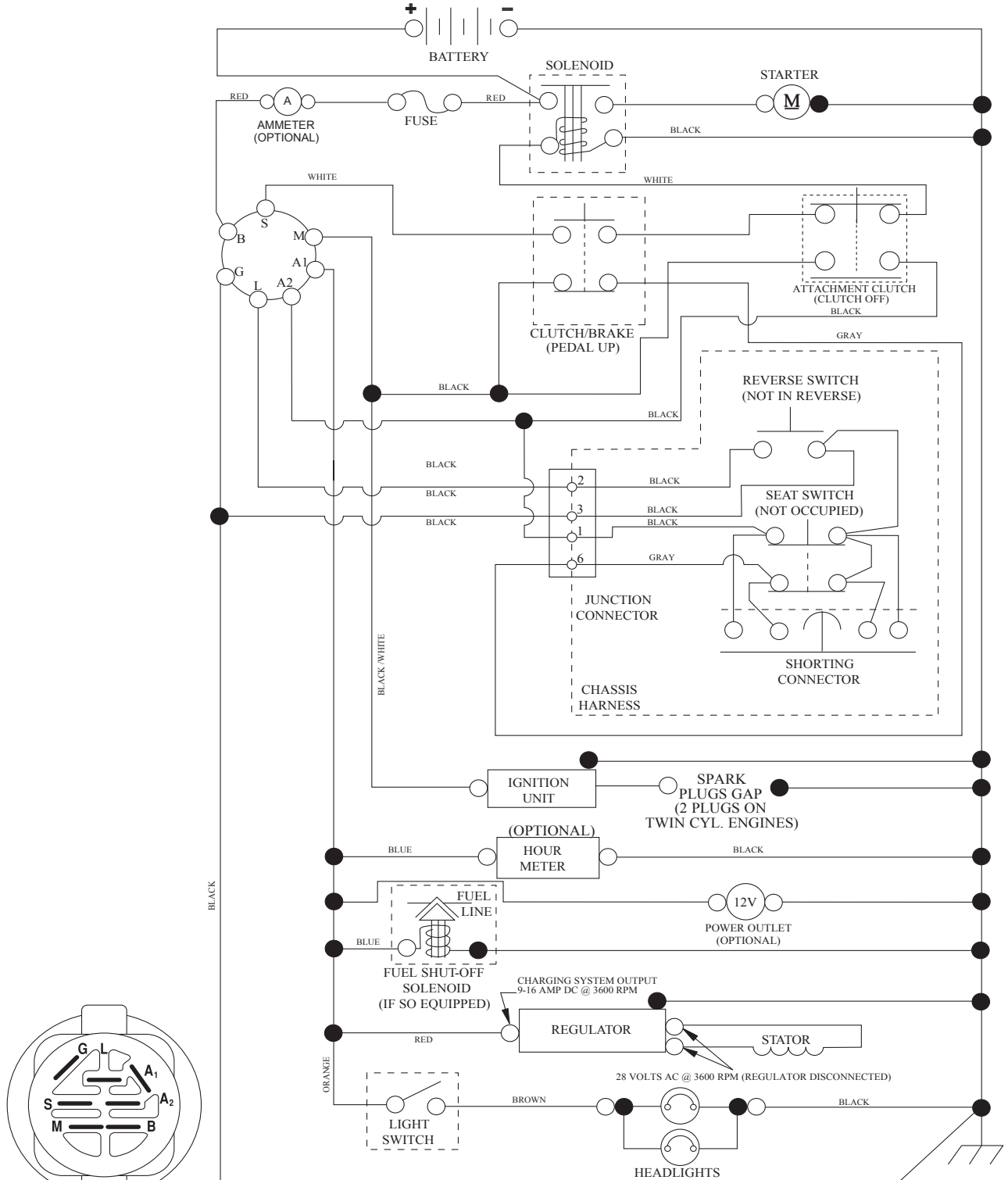

IGNITION SWITCH

POSITION	CIRCUIT	"MAKE"
OFF	M+G+A1	
RUN/OVERRIDE	B+A1	
RUN	B+A1	L+A2
START	B + S + A1	

03107

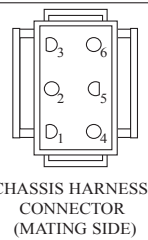

CHASSIS HARNESS CONNECTOR (MATING SIDE)

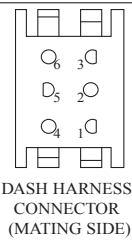

DASH HARNESS CONNECTOR (MATING SIDE)

WIRING INSULATED CLIPS
NOTE: IF WIRING INSULATED CLIPS WERE REMOVED FOR SERVICING OF UNIT, THEY SHOULD BE RE-INSTALLED TO PROPERLY SECURE YOUR WIRING.

●
NON-REMOVABLE CONNECTIONS

○
REMOVABLE CONNECTIONS

TRACTOR - - MODEL NO. LTH152 (96041003009), PRODUCT NO. 960 41 00-30
ELECTRICAL **32**

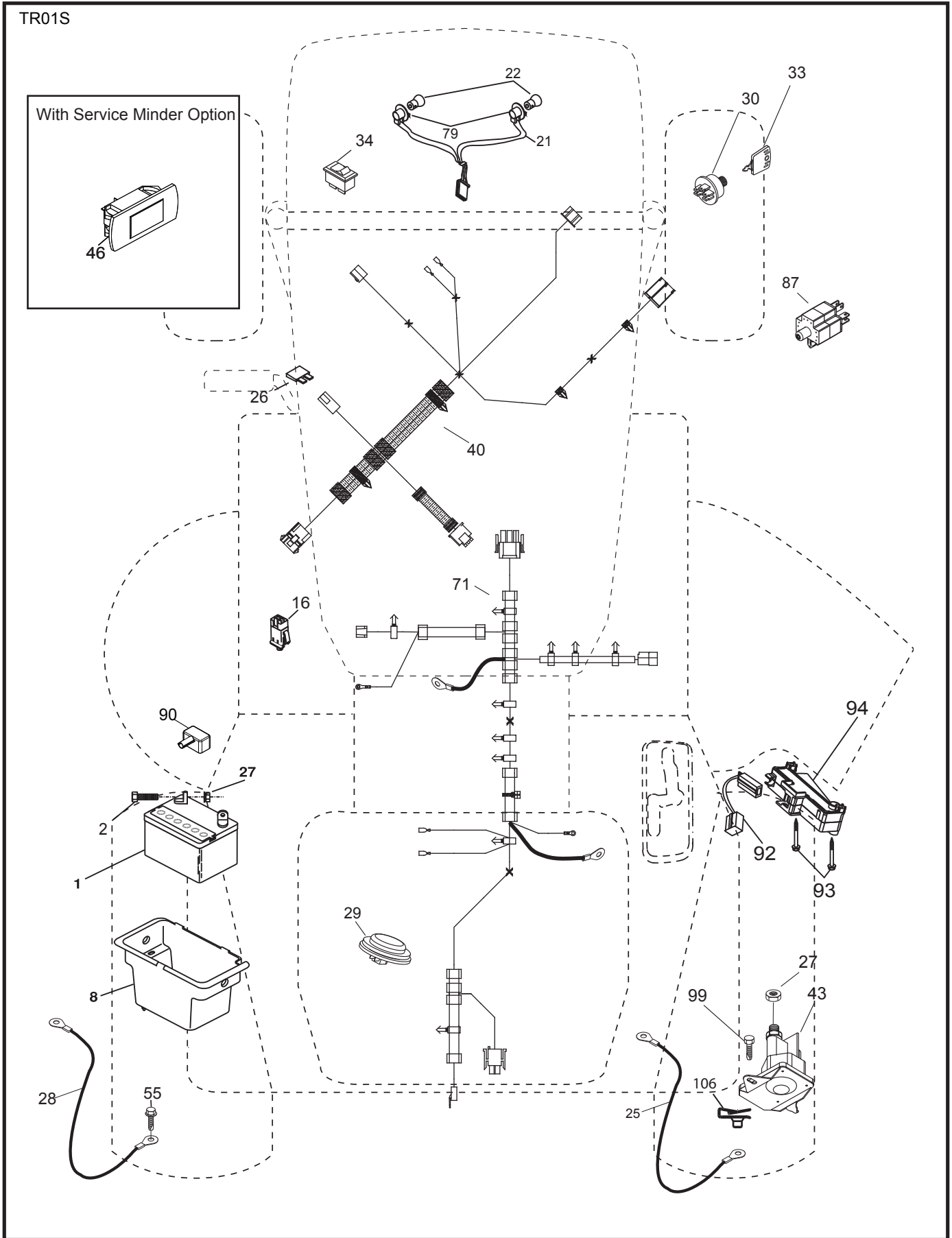

**TRACTOR - - MODEL NO. LTH152 (96041003009), PRODUCT NO. 960 41 00-30
ELECTRICAL 32**

KEY NO.	PART NO.	DESCRIPTION
1	532 16 34-65	Battery
2	874 76 04-12	Bolt Hex Head 1/4-20 x 3/4
8	532 19 32-28	Box Battery
16	532 17 61-38	Switch Interlock Push-In
21	532 40 02-52	Harness Socket Light w/4152J
22	532 00 41-52	Bulb Light
25	581 49 80-01	Cable Starter
26	532 17 51-58	Fuse
27	873 51 04-00	Nut Keps Hex 1/4-20 unc
28	532 42 16-86	Cable, Ground
29	532 40 15-45	Switch, Seat
30	532 19 33-50	Switch, Ign
33	532 41 19-35	Key/Chain
34	532 11 07-12	Switch Light/Reset
40	581 02 31-01	Harness Ign. Dash
43	532 19 25-07	Solenoid
55	817 06 05-12	Screw Thdrol 5/16-18 x 3/4 TYTT
71	581 02 30-01	Harness Ign. Chassis
79	532 17 52-42	Socket Asm
87	532 19 78-02	Switch Interlock Clutch Cable
90	532 43 53-95	Cover Terminal
92	532 19 66-15	Harness Pigtail Reverse Switch
93	532 19 25-40	Screw Plastite 10-14 x 2.0
94	532 19 18-34	Module Reverse ROS
99	817 67 04-12	Screw Hexwsh Thdrol 1/4-20 x 3/4
106	532 17 48-14	Palnut 1/4 Lugs

NOTE: All component dimensions given in U.S. inches
1 inch = 25.4 mm

TRACTOR - - MODEL NO. LTH152 (96041003009), PRODUCT NO. 960 41 00-30
CHASSIS AND ENCLOSURES **39**

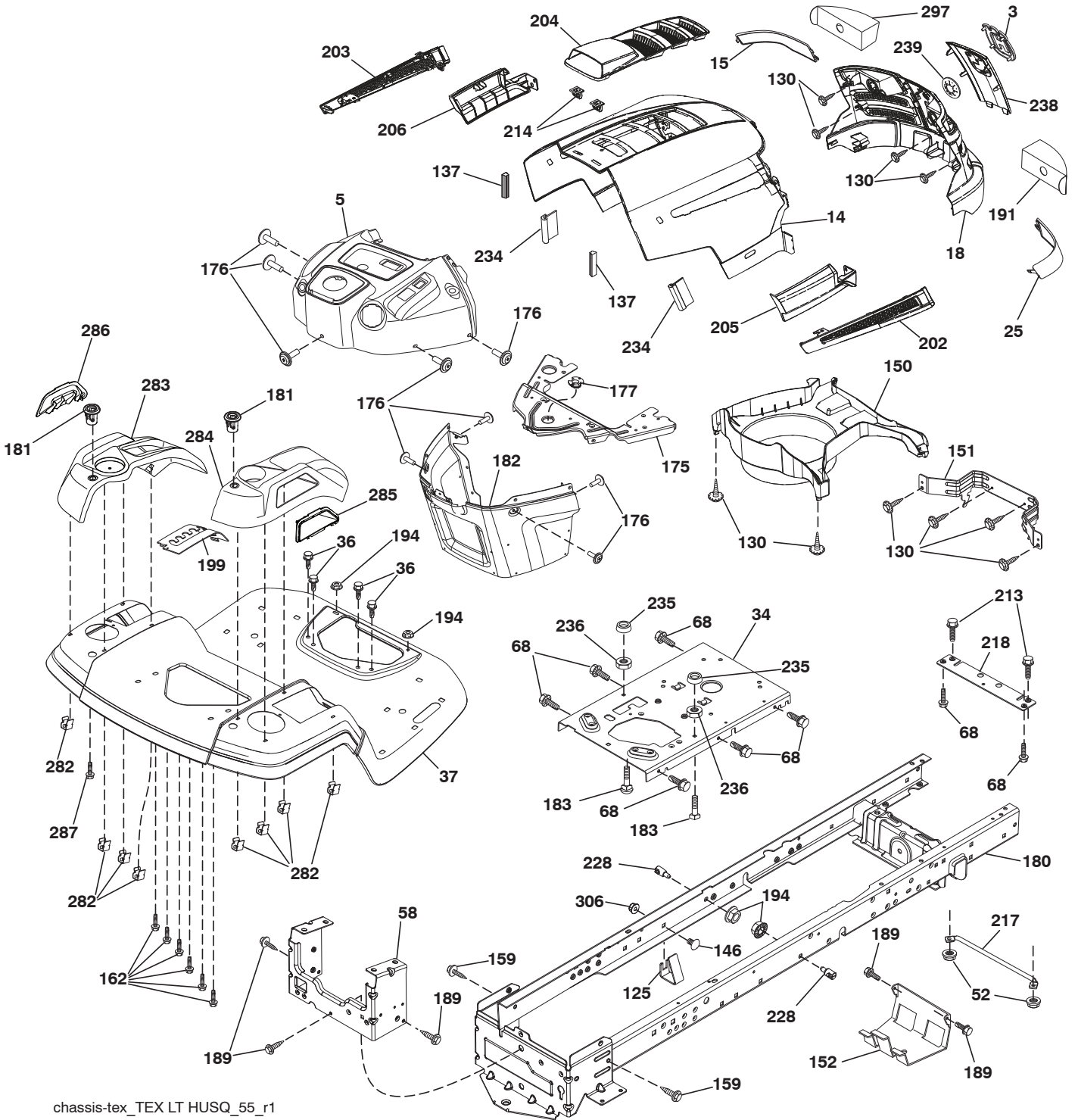

chassis-tex_TEX LT HUSQ_55_r1

**TRACTOR - - MODEL NO. LTH152 (96041003009), PRODUCT NO. 960 41 00-30
CHASSIS AND ENCLOSURES 39**

KEY NO.	PART NO.	DESCRIPTION
3	581 05 63-01	Logo
5	532 43 89-64	Dash
14	532 44 12-67	Hood
15	532 44 14-28	Lens LH
18	532 44 13-68	Grille
25	532 44 14-27	Lens RH
34	532 44 72-53	Plate Engine
36	817 06 05-12	Screw 5/16-18 x 3/4
37	532 44 12-66	Fender
52	873 68 05-00	Nut Crown Lock 5/16
58	532 41 22-80	Drawbar, Upper
68	817 49 05-08	Screw THDROL 5/16-18 x 1/2
125	581 68 48-01	Clip Fuel Line
130	532 41 63-58	Screw 10 x .750 BOS Thread
137	532 40 75-90	Bumper Dash
146	581 85 79-01	Bolt
150	532 40 75-37	Air Duct
151	532 40 78-07	Bracket Pivot
152	532 19 95-35	Shield Browning
159	817 00 06-12	Screw 3/8-7/16 x 3/4
162	532 14 24-32	Screw
175	532 19 94-72	Crossmember
176	532 40 07-76	Screw 10-24 x 5/8
177	532 19 52-28	Bushing Steering
180	532 41 50-63	Chassis
181	532 43 97-46	Bushing Fender
182	532 40 71-76	Dash Lower
183	874 52 05-20	Bolt 5/16-18 x 1-1/4
189	817 00 05-12	Screw 5/16-18 x 3/4
191	532 41 65-01	Insert Reflective RH
194	873 90 05-00	Nut Lock Hex Flange 5/16-18
199	532 41 34-85	Plate Deck Lift
202	532 44 13-42	Vent Side Hood RH
203	532 44 13-43	Vent Side Hood LH
204	532 44 13-75	Vent Top Hood
205	532 44 13-44	Skirt Side RH
206	532 44 13-45	Skirt Side LH
213	874 76 05-12	Bolt 5/16-18 x 3/4
214	532 19 91-45	Clip Retainer
217	532 40 91-67	Rod Pivot Hood
218	532 19 63-95	X-Piece Hood Stop
228	532 19 51-61	Stud Fastener
234	532 40 47-42	Bumper Hood
235	532 40 61-29	Spacer Fender
236	873 93 05-00	Nut Lock 5/16-18 UNC
238	532 44 13-74	Trim
239	532 40 48-83	Clip Tinnerman
282	532 41 41-10	Clip Retainer Console
283	532 43 91-52	Console Deck Lift
284	532 43 91-48	Console Shift
285	532 41 63-15	Console Insert R.H.
286	532 41 63-17	Console Insert L.H.
287	817 60 04-06	Screw Hex Washhead 1/4-20 x 3/8
297	532 40 66-65	Insert Reflective LH
306	873 90 06-00	Nut
- - -	532 43 99-76	Plug Dash SRVMNDR

NOTE: All component dimensions given in U.S. inches
1 inch = 25.4 mm

TRACTOR - - MODEL NO. LTH152 (96041003009), PRODUCT NO. 960 41 00-30
DRIVE **40**

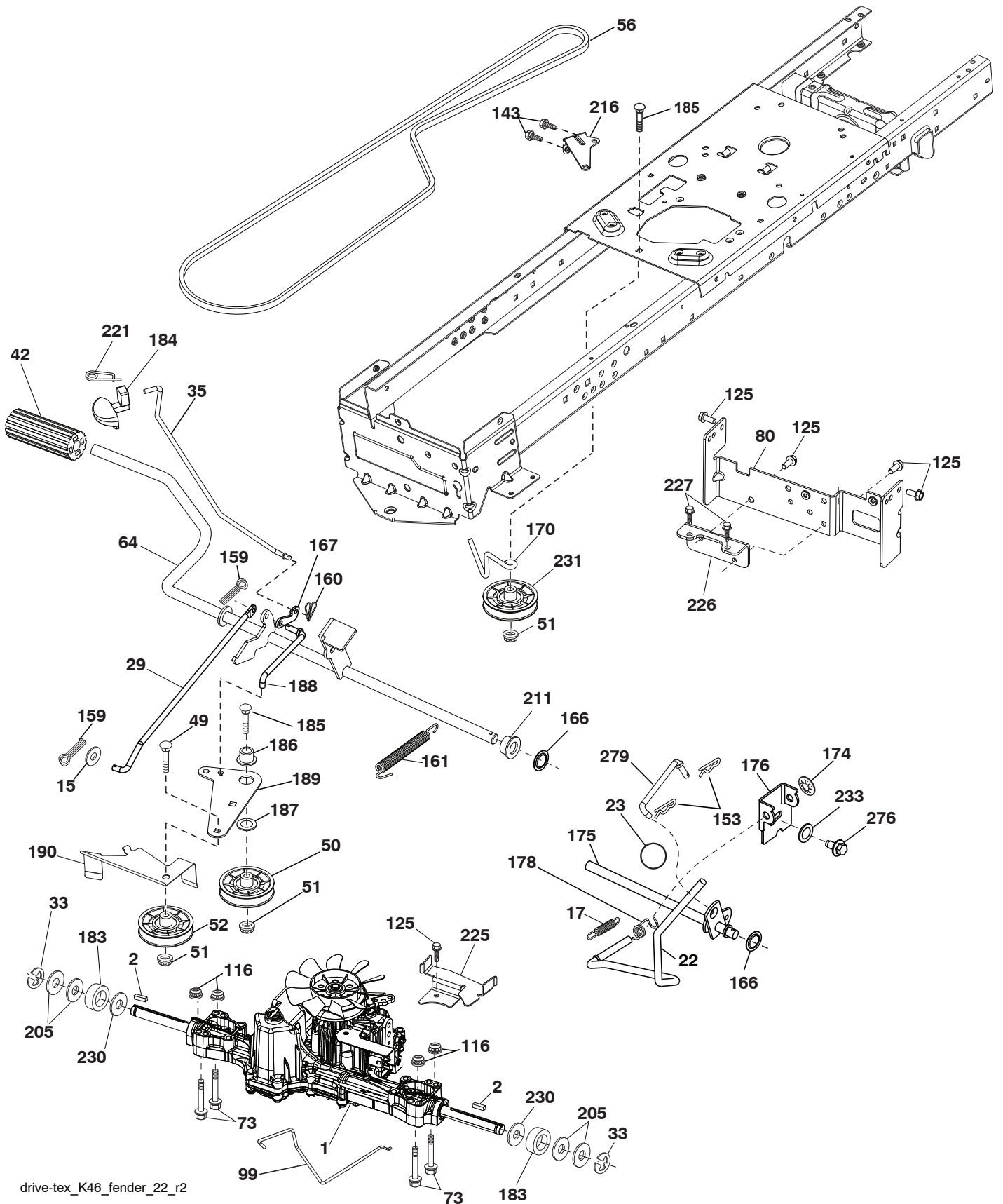

drive-tex_K46_fender_22_r2

**TRACTOR - - MODEL NO. LTH152 (96041003009), PRODUCT NO. 960 41 00-30
DRIVE **40****

KEY NO.	PART NO.	DESCRIPTION	KEY NO.	PART NO.	DESCRIPTION
1	-----	Transaxle, TuffTorq K46BA (448348)(Order parts from trans-axle manufacturer.)	170	532 41 34-30	Keeper Belt Centerspan
2	532 12 35-83	Key Square	174	532 19 72-89	Nut Push
15	819 13 13-16	Washer 13/32 x 13/16 x 16 Ga.	175	532 40 85-39	Shaft Asm Shift
17	532 41 36-78	Spring, Brake	176	532 19 62-14	Arm Clevis Rod Shift
22	532 19 76-60	Rod Shift	178	532 19 74-56	Spring Shift
23	532 12 12-74	Knob	183	532 13 70-57	Spacer Split
29	532 40 38-06	Rod, Brake	184	532 44 14-07	Handle Parking Brake
33	812 00 00-01	Ring E	185	872 11 06-22	Bolt
35	532 40 10-31	Rod, Brake, Park	186	532 19 43-21	Spacer Retainer
42	532 12 48-72	Cover, Foot Pedal	187	819 13 32-10	Washer
49	872 11 06-14	Bolt	188	532 19 43-23	Link Clutch Ground Drive
50	532 19 43-27	Pulley Idler Flat	189	532 19 43-17	Bellcrank Ground Drive
51	873 90 06-00	Lock Nut 3/8-16	190	532 19 43-18	Keeper Bellcrank Ground Drive
52	532 19 43-26	Idler V-Groove 910" Offset	205	532 12 17-48	Washer 25/32 x 1-5/8 x 16 Ga.
56	532 13 09-69	V-Belt, Drive	211	532 19 62-12	Bushing Brake Shaft
64	532 19 62-00	Shaft Asm. Pedal Brake Control	216	532 19 61-31	Bracket Pulley Idler
73	874 49 05-40	Bolt 5/16-18 x 1/2 Gr. 5	221	532 40 31-87	Retainer Spring Clip Handle
80	532 44 06-19	Strap Torque	225	532 40 33-19	Keeper Belt Trans.
99	532 41 57-42	Rod Spring Bypass	227	817 49 05-12	Screw 5/16-18 x 3/4
116	873 90 05-00	Nut Lock Hex Flange 5/16-18	226	532 40 15-64	Bracket Mount Torque
125	817 00 05-12	Screw 5/16 - 18 x 3/4	230	532 18 89-67	Washer Hardened
143	817 49 05-08	Screw 5/16 - 18 x 1/2	231	532 40 72-87	Idler V-Groove 1.688" Offset
153	532 12 47-88	Retainer Spring 1"	233	532 40 52-96	Washer Serrated
159	876 02 04-12	Pin Cotter 1/8 x 3/4	276	874 78 07-16	Bolt 7/16-14 x 1 Gr. 5
160	532 16 94-84	Retainer Clip	279	532 41 31-50	Link Shift
161	532 10 57-09	Spring, Return, Clutch			
166	532 42 91-64	Nut Push			
167	532 40 52-57	Latch Brake Parking			

NOTE: All component dimensions given in U.S. inches
1 inch = 25.4 mm

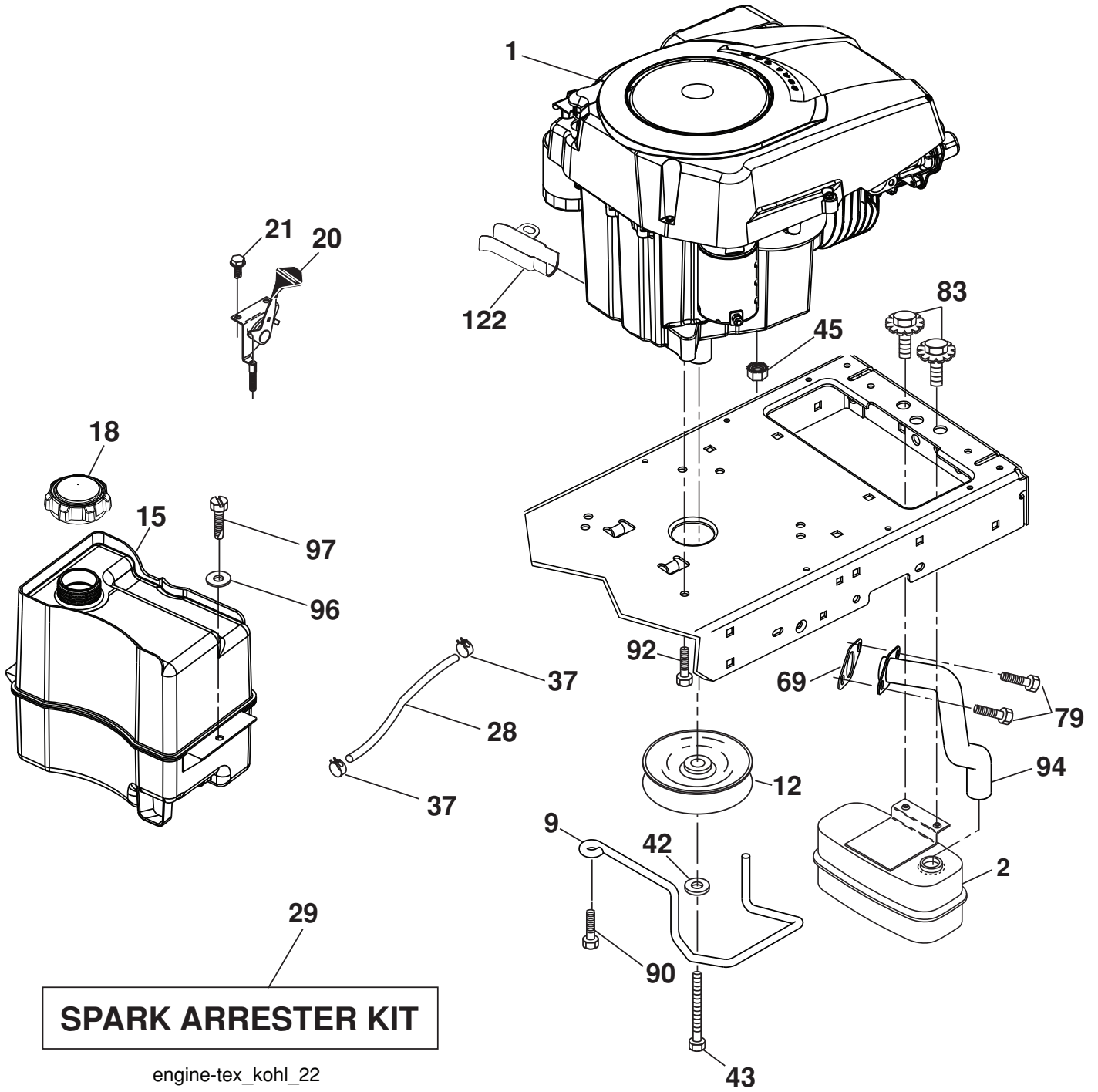

SPARK ARRESTER KIT

engine-tex_kohl_22

**TRACTOR - - MODEL NO. LTH152 (96041003009), PRODUCT NO. 960 41 00-30
ENGINE 24**

KEY NO.	PART NO.	DESCRIPTION
1	-----	Engine Kohler Model No. SV470-3212 (438330)(Order parts from engine manufacturer.)
2	532 18 86-55	Muffler
9	532 19 43-20	Keeper Belt Engine
12	532 40 54-71	Pulley Engine
15	532 40 75-45	Tank Fuel 1.5
18	532 43 02-20	Cap Asm
20	532 18 38-97	Control Throttle
21	532 41 63-58	Screw #10 x 0.750
28	532 13 70-40	Fuel Line
29	532 13 71-80	Spark Arrester Kit
37	532 12 34-87	Clamp Hose
42	810 04 07-00	Bolt 5/16-18 unc x 3/4 w/Sems
43	532 17 39-37	Bolt Hex 7/16-20 x 4 Gr. 5
45	873 51 04-00	Nut Keps Hex 1/4-20 unc
69	532 18 59-09	Gasket
79	532 19 23-34	Screw 5/16 - 18 x .75
83	532 17 18-77	Bolt 5/16-18 unc x 3/4 w/Sems
90	817 00 06-16	Screw 3/8-16 x 1
92	817 12 06-16	Screw 3/8-16 x 1
94	532 18 86-54	Tube Exhaust
96	819 09 14-16	Washer 9/32 x 7/8 x 16 Ga.
97	817 67 04-12	Screw 1/4-20 x 3/4
122	532 42 19-22	Extension Drain Oil

NOTE: All component dimensions given in U.S. inches
1 inch = 25.4 mm

TRACTOR - - MODEL NO. LTH152 (96041003009), PRODUCT NO. 960 41 00-30
STEERING ASSEMBLY **41**

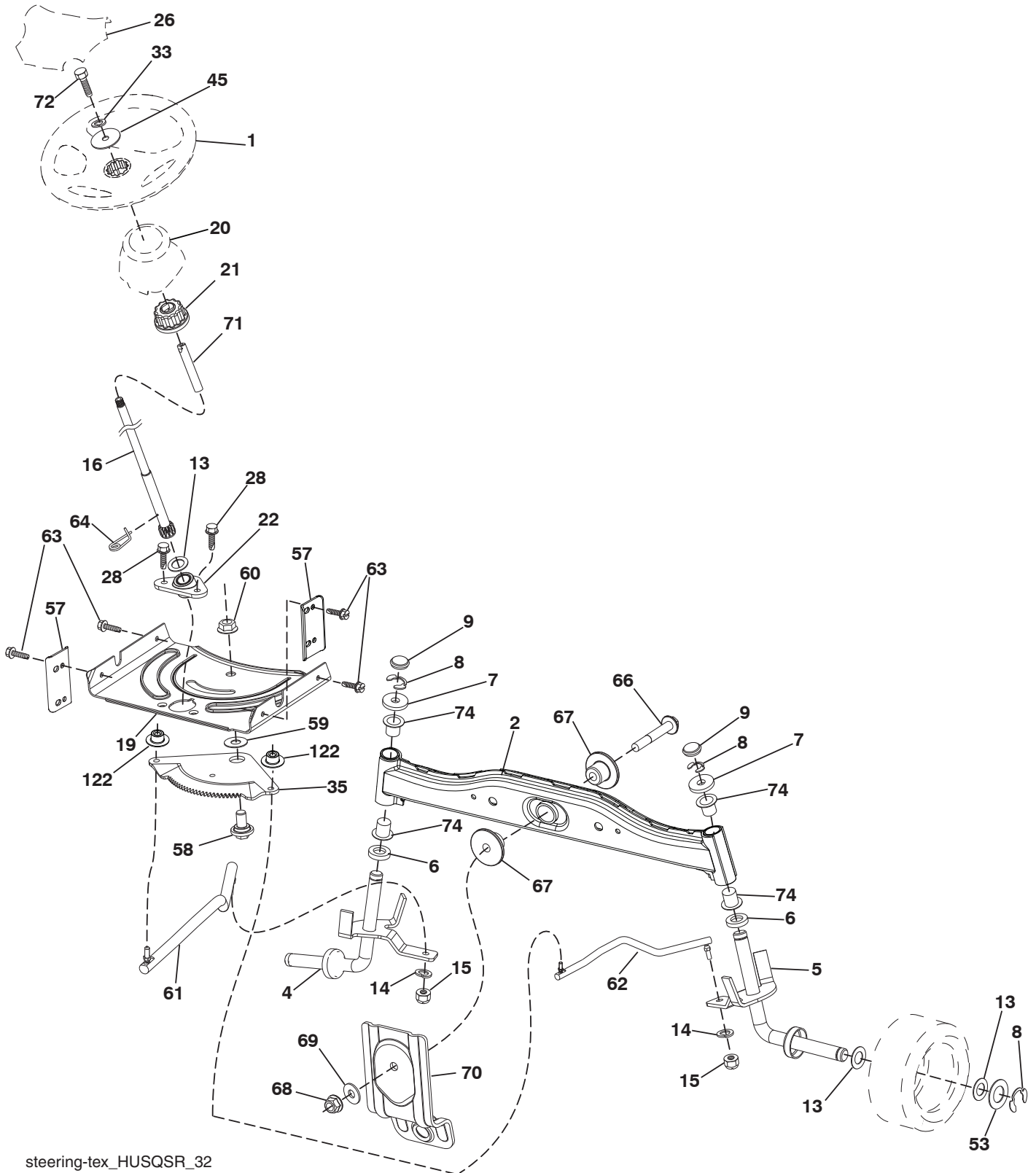

steering-tex_HUSQSR_32

**TRACTOR - - MODEL NO. LTH152 (96041003009), PRODUCT NO. 960 41 00-30
STEERING ASSEMBLY 41**

KEY NO.	PART NO.	DESCRIPTION
1	532 43 97-40	Wheel, Steering Husq SR
2	532 41 81-68	Axle Asm.
4	532 40 30-87	Spindle Asm., LH
5	532 40 30-88	Spindle Asm., RH
6	532 12 49-31	Bearing, Race Thrust Harden
7	532 12 17-48	Washer 25/32 x 1-5/8 x 16 Ga.
8	812 00 00-29	Ring, Clip #T5304-75
9	532 12 12-32	Cap, Spindle
13	532 12 17-49	Washer 25/32 x 1-1/4 x 16 Ga.
14	810 04 06-00	Washer, Lock Hvy Hlcl Spr 3/8
15	873 54 06-00	Nut, Crown Lock 3/8-24 unf
16	532 42 93-73	Shaft Steering
19	532 19 47-29	Plate Steering
20	532 44 14-25	Boot, Steering
21	532 18 67-37	Adapter, Wheel Steering
22	532 42 05-37	Strg. Supt. Lower
26	532 43 97-43	Insert, Wheel Steering Husq SR
28	817 00 06-12	Screw 3/8-16 x 3/4
33	810 04 05-00	Washer Lock 5/16
35	532 19 47-32	Gear, Sector Plate
45	819 11 38-12	Washer 11/32 x 3/8 x 12 Ga.
53	532 18 89-67	Washer Hardened .793 x 1.637 x .060
57	532 40 74-65	Bracket Upstop
58	532 19 47-47	Bolt Shoulder Sector Pivot CFM
59	532 19 47-48	Washer Thrust Sector Steering
60	873 97 10-00	Nut Flange Lock 5/8-11
61	532 19 47-40	Draglink, LH
62	532 19 47-41	Draglink, RH
63	817 00 05-12	Screw 5/16-18 x 3/4
64	532 19 98-49	Retainer Clip Spring Steering
66	871 02 07-48	Bolt Hex Fghd 7/16-14 x 3 Serr
67	532 19 47-37	Bushing PM Front Axle
68	873 90 07-00	Nut Lock Flange 7/16-14 Gr. 5
69	532 19 91-62	Washer 1.5 x .505 x .118
70	532 19 61-97	Bracket Deck Susp. Front
71	532 19 07-52	Shaft Extension Steering
72	532 42 89-82	Bolt Fin Hex 5/16-18 x 4 w/Patch
74	532 12 49-37	Bearing
122	532 44 49-62	Cap Gear

NOTE: All component dimensions given in U.S. inches
1 inch = 25.4 mm

TRACTOR - - MODEL NO. LTH152 (96041003009), PRODUCT NO. 960 41 00-30
MOWER DECK 44

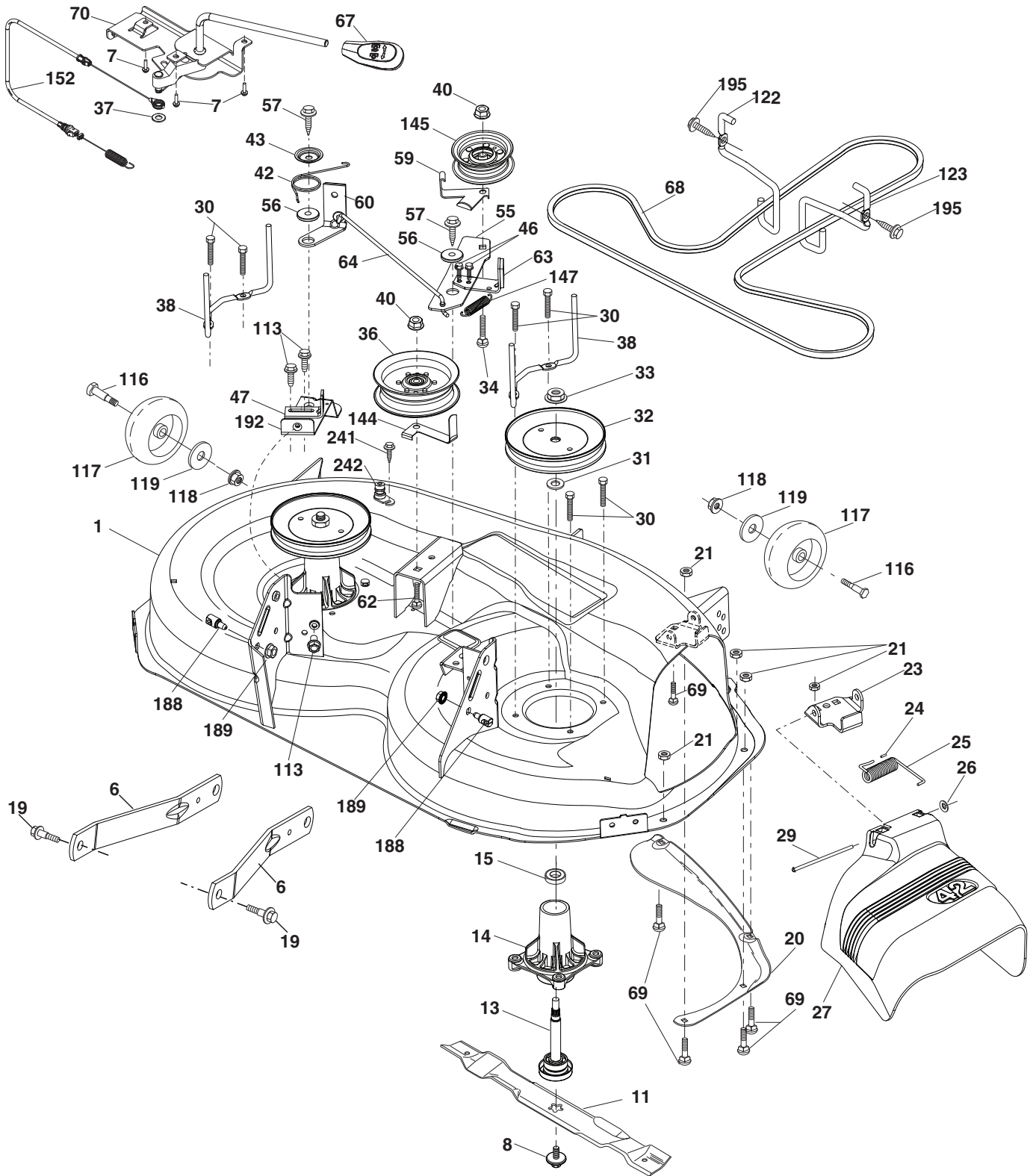

**TRACTOR - - MODEL NO. LTH152 (96041003009), PRODUCT NO. 960 41 00-30
MOWER DECK 44**

KEY NO.	PART NO.	DESCRIPTION	KEY NO.	PART NO.	DESCRIPTION
1	532 43 98-17	Mower Housing	60	532 19 72-61	Arm Brake Mower
6	532 19 51-86	Arm Suspension	62	872 11 06-16	Bolt 3/8-16 unc x 2
7	532 41 63-58	Screw #10 x 0.750	63	532 19 94-77	Arm Brake Mower
8	532 19 30-03	Bolt/Washer asm 7/16-20 unf	64	532 19 99-18	Link Brake
11	532 13 89-71	Blade Mower 42" Hi Lift Premium (For better wear when mulching)	67	532 40 30-12	Handle Clutch Cable
13	532 19 28-72	Shaft Assembly, Mandrel	68	532 42 96-36	V-Belt
14	532 18 72-81	Housing, Mandrel	69	872 14 05-05	Bolt
15	532 11 04-85	Bearing, Ball, Mandrel	70	532 40 12-46	Clutch Asm Manual
19	532 19 65-39	Bolt, Shoulder	113	817 00 05-10	Screw 5/16-18
20	532 15 97-70	Baffle Vortex	116	532 12 48-42	Bolt Shoulder
21	873 68 05-00	Nut, Crownlock 5/16-18 unc	117	532 18 86-06	Wheel Gauge
23	532 19 25-57	Bracket, Deflector	118	873 90 06-00	Nut Centerlock 3/8-16 unc
24	532 10 53-04	Cap, Sleeve	119	819 12 14-14	Washer 3/8 x 7/8 x 14 Ga.
25	532 19 70-26	Spring, Torsion, Deflector	122	532 19 72-58	Keeper Belt Engine LH
26	532 11 04-52	Nut, Push	123	532 19 72-59	Keeper Belt Engine RH
27	532 40 30-04	Shield, Deflector	144	532 19 92-04	Keeper Belt
29	532 13 14-91	Rod, Hinge	145	532 19 31-97	Pulley Idler
30	532 17 39-84	Screw Thdrol Rolling Wsh Hd	147	532 40 19-71	Spring Return
31	532 18 76-90	Washer, Spacer	152	532 43 51-11	Manual Clutch Cable
32	532 19 74-73	Pulley, Mandrel	188	532 19 51-61	Stud Fastener
33	532 40 02-34	Nut, Toplock, Flanged	189	873 90 05-00	Nut Lock Hex Flange
34	872 11 06-12	Bolt Carr Sh. 3/8-16 x 1-1/2 Gr. 5	192	532 19 72-60	Bracket Brake Stand LH
36	532 19 73-79	Pulley, Idler, Flat	195	817 00 06-12	Screw 3/8-16 x 3/4
37	819 13 13-16	Washer	241	532 15 29-27	Screw TT#10-32 5. 3/8 Flange
38	532 43 25-20	Keeper Belt Mandrel	242	532 41 55-98	Port Washout
40	873 90 06-00	Nut, Lock Flg. 3/8-16 unc	--	532 19 28-70	Mandrel Assembly (Includes hous- ing, shaft assembly, and bearing only - pulley/nut/washer and blade bolt/washers not included)
42	532 19 84-10	Spring Torsion Brake	--	532 43 29-37	Replacement Mower, Complete
43	532 19 72-56	Spring Torsion Retainer			
46	532 13 77-29	Screw 1/4-20 x 5/8			
47	532 19 72-50	Bracket Clutch Cable			
55	532 43 71-10	Arm, Idler			
56	532 19 90-92	Spacer, Retainer			
57	817 00 06-16	Screw 3/8-16 x 1			
59	532 14 10-43	Guard, Tuv Idler			

NOTE: All component dimensions given in U.S. inches
1 inch = 25.4 mm

TRACTOR - - MODEL NO. LTH152 (96041003009), PRODUCT NO. 960 41 00-30
 MOWER LIFT **45**

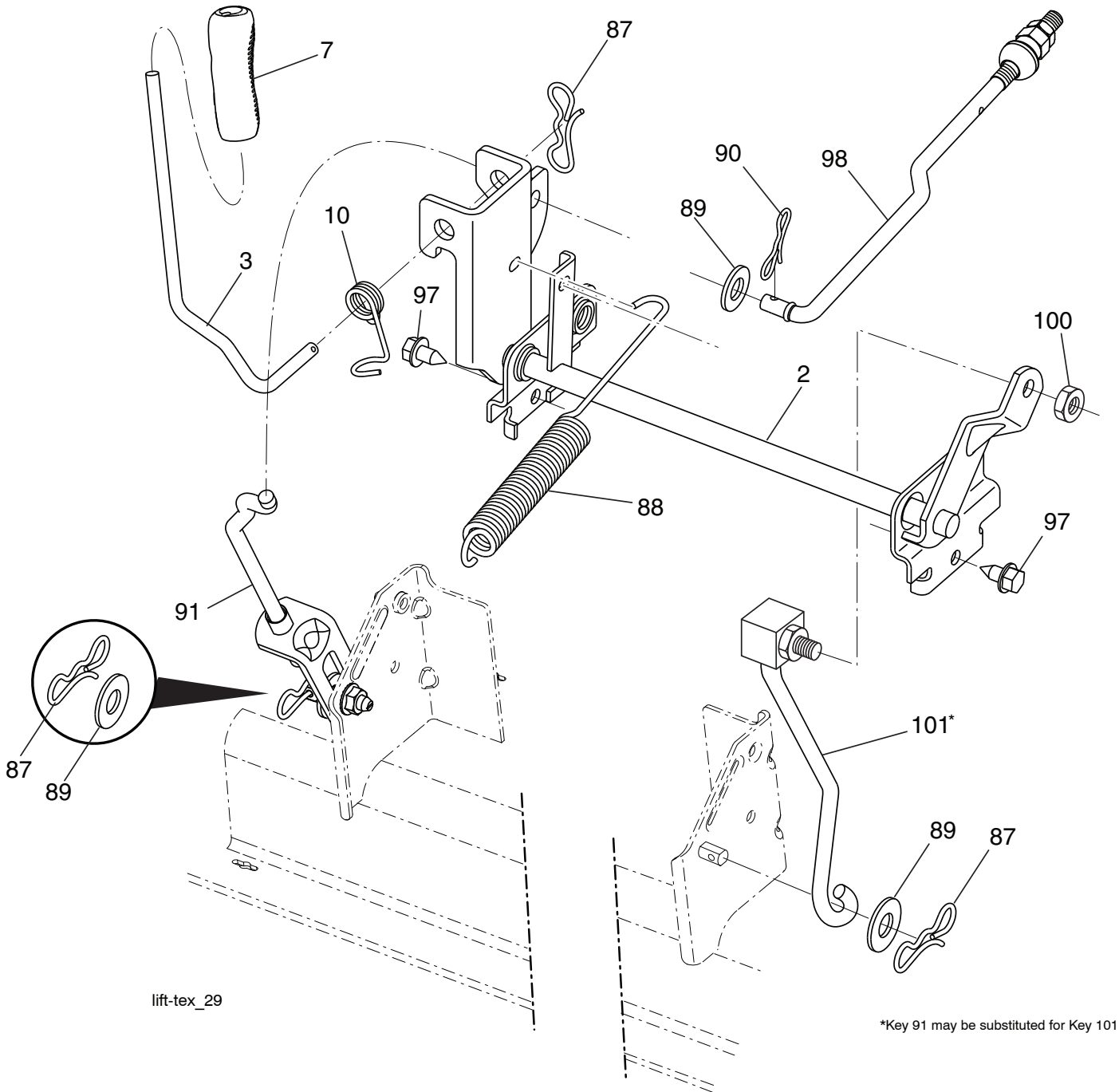

lift-tex_29

*Key 91 may be substituted for Key 101

KEY NO.	PART NO.	DESCRIPTION
2	532 42 20-27	Shaft Asm., Lift
3	532 19 52-31	Lever Asm., Lift RH
7	580 96 23-01	Grip, Lever
10	532 19 63-14	Spring Torsion
87	532 19 42-09	Pin Cotter 7/16 Bow Tie Lock
88	532 41 07-10	Spring Lift Assist
89	819 19 19-12	Washer Clear Zinc
90	532 19 42-08	Pin Cotter 5/16 Bow Tie Lock

KEY NO.	PART NO.	DESCRIPTION
91	532 19 51-81	Link Lift Susp Mower Rear
97	817 00 06-12	Screw 3/8-16x.75 Smgml Tap/R.Z
98	532 19 52-70	Link Lift Susp. Front Mower
100	873 93 06-00	Nut Centerlock 3/8-16
101	532 40 70-03	Link Asm. Lift FXD

NOTE: All component dimensions given in U.S. inches
 1 inch = 25.4 mm

**TRACTOR - - MODEL NO. LTH152 (96041003009), PRODUCT NO. 960 41 00-30
SEAT ASSEMBLY 42**

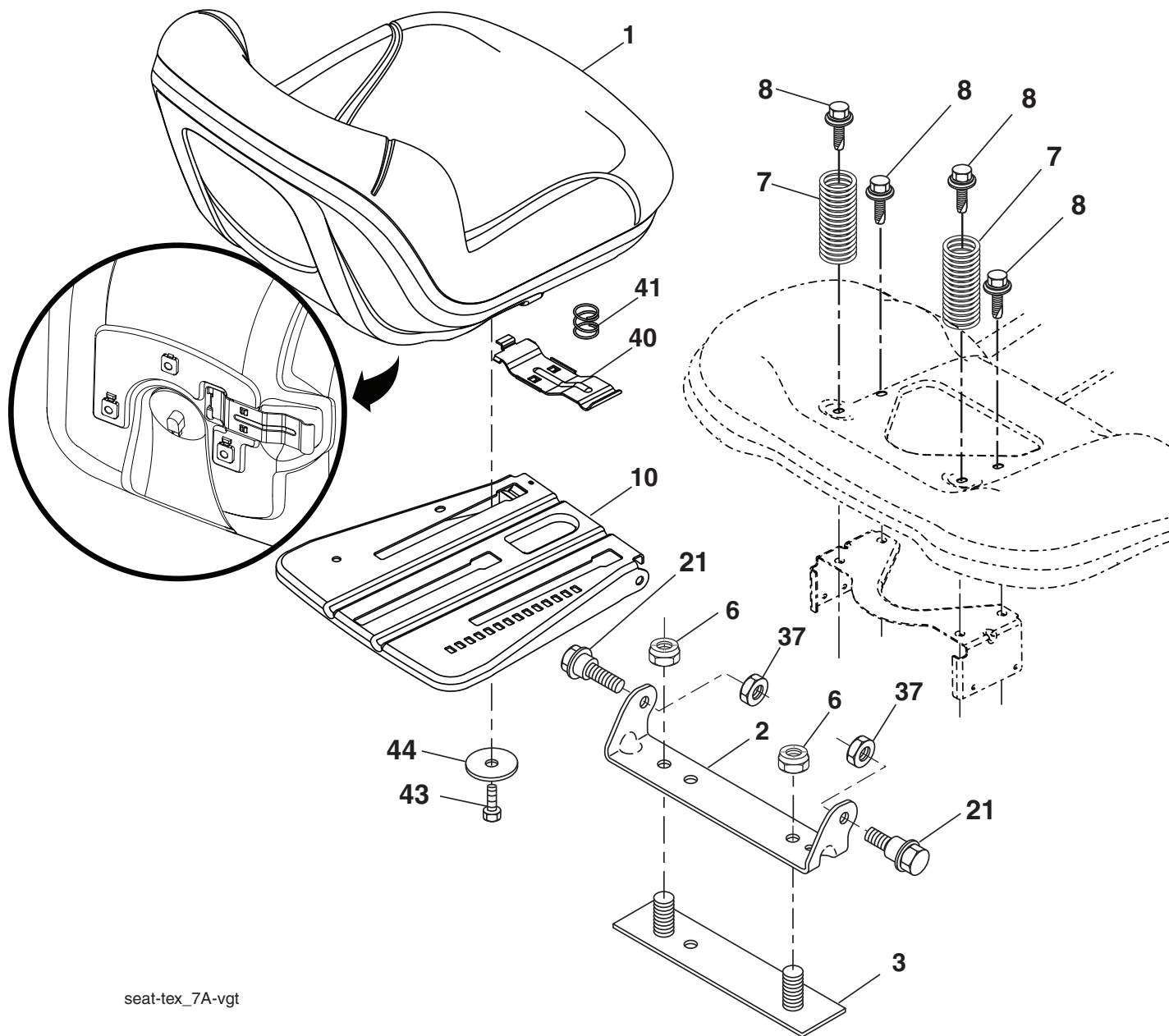

seat-tex_7A-vgt

KEY NO.	PART NO.	DESCRIPTION
1	532 43 98-19	Seat
2	532 18 01-66	Bracket Pivot Fender
3	532 14 06-75	Strap, Asm Fender
6	873 80 06-00	Nut, Lock w/Ins. 3/8-16 unc
7	532 12 41-81	Spring, Seat Cprsn
8	532 17 18-77	Bolt 5/16-18 unc x 3/4 w/Sems
10	532 19 69-77	Pan, Seat
21	532 17 18-52	Bolt, Shoulder 5/16-18

KEY NO.	PART NO.	DESCRIPTION
37	873 80 05-00	Nut, Lock 5/16-18 unc
40	532 19 76-61	Handle Slide
41	532 19 82-00	Spring Latch
43	874 76 06-12	Bolt 3/8-16 unc x 3/4
44	819 13 38-12	Washer 13/32 x 2-3/8 x 12 Ga.

NOTE: All component dimensions given in U.S. inches
1 inch = 25.4 mm

