

ILLUSTRATED PARTS LIST

MODEL NUMBER 5524ST

PRODUCT NUMBER 961 91 00 16

MFG. ID. NUMBER 96191001613

REPAIR PARTS

AUGER HOUSING / IMPELLER ASSEMBLY

SNOW THROWER - MODEL NO. 5524ST (96191001613), PRODUCT NO. 961 91 00 16

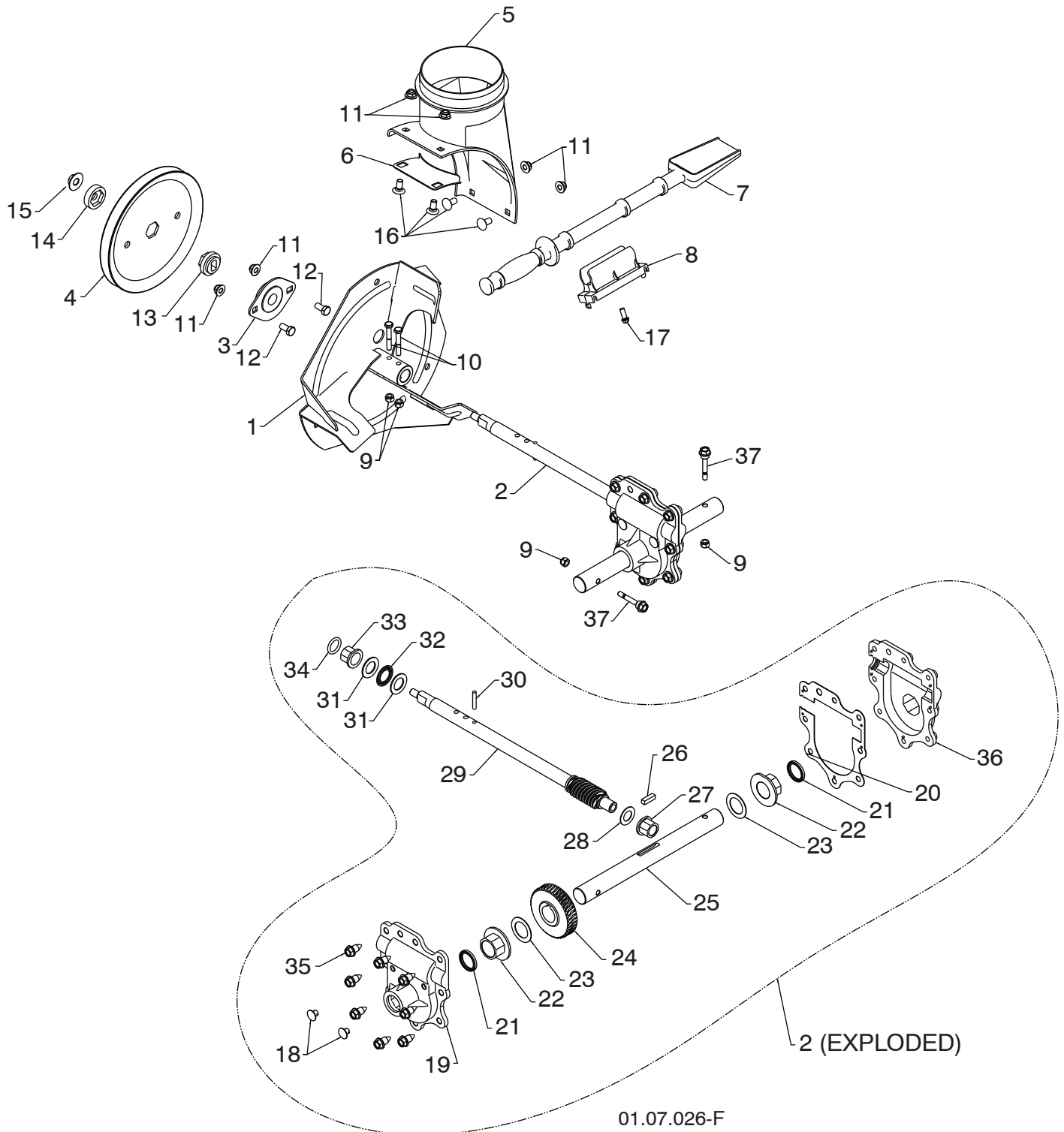

NOTE: All component dimensions given in U.S. inches. 1 inch = 25.4 mm

IMPORTANT: Use only Original Equipment Manufacturer (O.E.M.) replacement parts. Failure to do so could be hazardous, damage your snow thrower and void your warranty.

REPAIR PARTS

AUGER HOUSING / IMPELLER ASSEMBLY

SNOW THROWER - MODEL NO. **5524ST** (96191001613), PRODUCT NO. 961 91 00 16

KEY NO.	PART NO.	DESCRIPTION
1	532 18 41-05	IMPELLER
2	532 42 71-48	GEARBOX ASSEMBLY
3	532 18 89-09	BEARING
4	532 42 71-46	IMPELLER PULLEY
5	532 44 24-38	DISCHARGE BASE
6	532 18 40-95	CORNER BRACKET
7	532 19 21-99	CLEAN OUT TOOL
8	532 40 54-00	TOOL CLIP
9	873 80 04-00	NUT 1/4-20
10	874 78 04-26	SCREW 1/4-20 X .625
11	532 42 79-42	NUT 5/16-18
12	532 16 31-83	SCREW 5/16-18 X .625
13	532 42 71-45	IMPELLER HUB
14	532 42 71-54	IMPELLER SLEEVE
15	532 14 52-12	FLANGE NUT 3/8-16
16	532 18 03-55	CARRIAGE BOLT
17	532 19 41-89	SCREW 13-16 X .625
18	532 40 77-60	PLUG
19	532 42 73-02	GEARBOX COVER RH
20	532 42 73-45	GASKET
21	532 40 77-70	SEAL
22	532 40 77-62	BEARING
23	532 17 46-97	THRUST WASHER 1.00
24	532 40 77-63	WORM GEAR
25	532 40 77-64	AUGER SHAFT
26	532 18 92-82	SQUARE KEY
27	532 40 77-58	BEARING
28	532 17 46-83	THRUST WASHER
29	532 42 71-47	IMPELLER SHAFT
30	532 18 42-05	ROLL PIN
31	532 17 46-81	THRUST WASHER
32	532 17 46-84	THRUST BEARING
33	532 40 77-69	BEARING
34	532 40 77-68	O-RING
35	532 40 77-67	SCREW 5/16-18 X .750
36	532 42 73-17	GEARBOX COVER LH
37	532 19 20-90	SHEAR BOLT

NOTE: All component dimensions given in U.S. inches. 1 inch = 25.4 mm

IMPORTANT: Use only Original Equipment Manufacturer (O.E.M.) replacement parts. Failure to do so could be hazardous, damage your snow thrower and void your warranty.

REPAIR PARTS

AUGER HOUSING / IMPELLER ASSEMBLY

SNOW THROWER - MODEL NO. 5524ST (96191001613), PRODUCT NO. 961 91 00 16

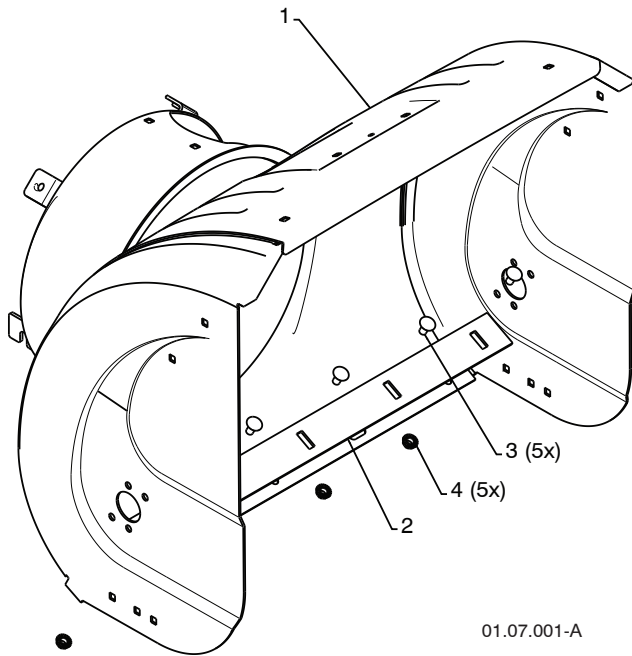

01.07.001-A

KEY NO.	PART NO.	DESCRIPTION
1	532 40 78-80	AUGER HOUSING
2	532 40 78-25	SCRAPER BAR
3	872 27 05-05	CARRIAGE BOLT 5/16-18 X .625
4	532 15 53-77	NUT 5/16-18

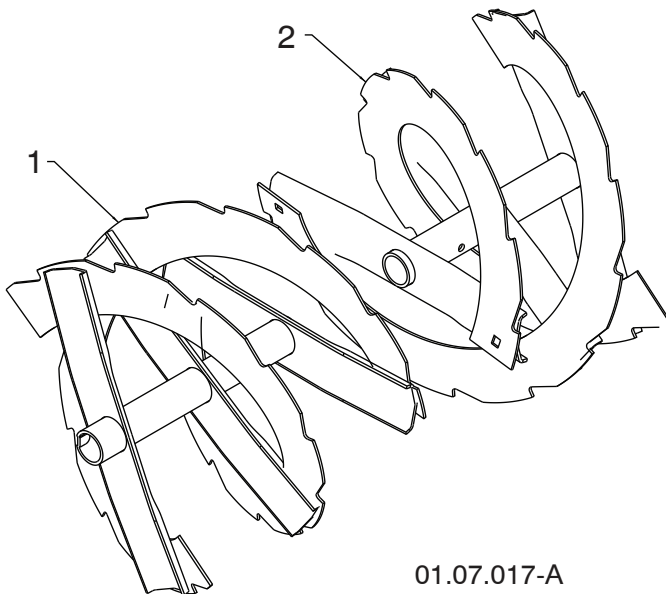

01.07.017-A

KEY NO.	PART NO.	DESCRIPTION
1	532 42 10-72	AUGER ASSEMBLY LH 24
2	532 42 10-73	AUGER ASSEMBLY RH 24

NOTE: All component dimensions given in U.S. inches. 1 inch = 25.4 mm
IMPORTANT: Use only Original Equipment Manufacturer (O.E.M.) replacement parts.
Failure to do so could be hazardous, damage your snow thrower and void your warranty.

REPAIR PARTS

AUGER HOUSING / IMPELLER ASSEMBLY

SNOW THROWER - MODEL NO. **5524ST** (96191001613), PRODUCT NO. 961 91 00 16

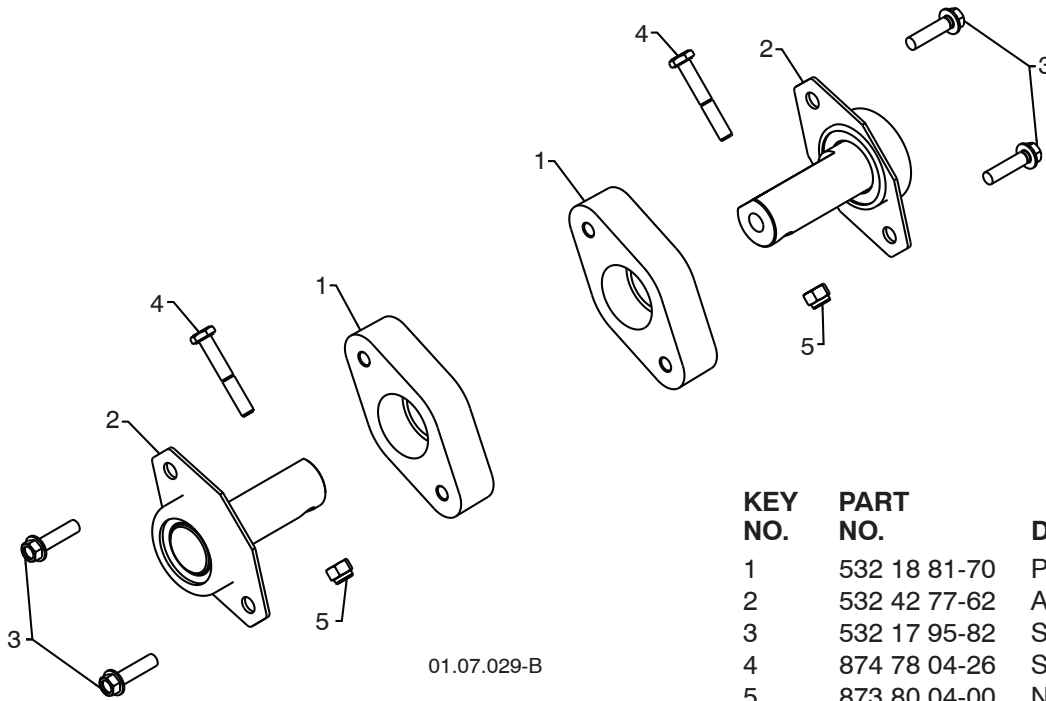

KEY NO.	PART NO.	DESCRIPTION
1	532 18 81-70	PLASTIC RETAINER
2	532 42 77-62	AUGER BALL BEARING
3	532 17 95-82	SCREW 5/16-18 X 1.00
4	874 78 04-26	SCREW 1/4-20 X .625
5	873 80 04-00	NUT 1/4-20

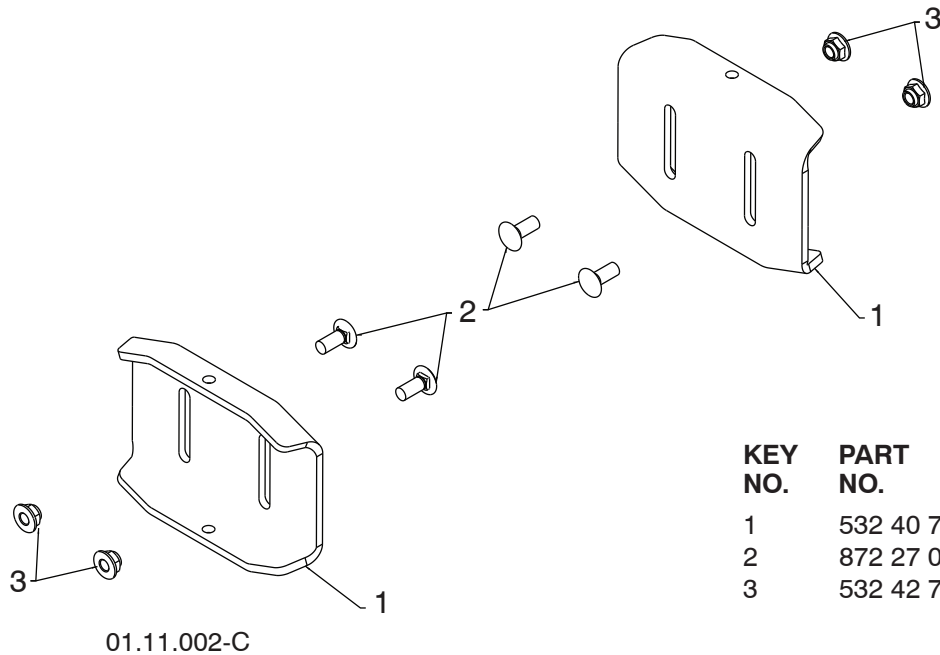

KEY NO.	PART NO.	DESCRIPTION
1	532 40 78-34	SKID PLATE
2	872 27 05-06	CARRIAGE BOLT 5/16-18 X .750
3	532 42 79-42	NUT 5/16-18

NOTE: All component dimensions given in U.S. inches. 1 inch = 25.4 mm
IMPORTANT: Use only Original Equipment Manufacturer (O.E.M.) replacement parts.
 Failure to do so could be hazardous, damage your snow thrower and void your warranty.

REPAIR PARTS

CONTROL PANEL / DISCHARGE CHUTE

SNOW THROWER - MODEL NO. 5524ST (96191001613), PRODUCT NO. 961 91 00 16

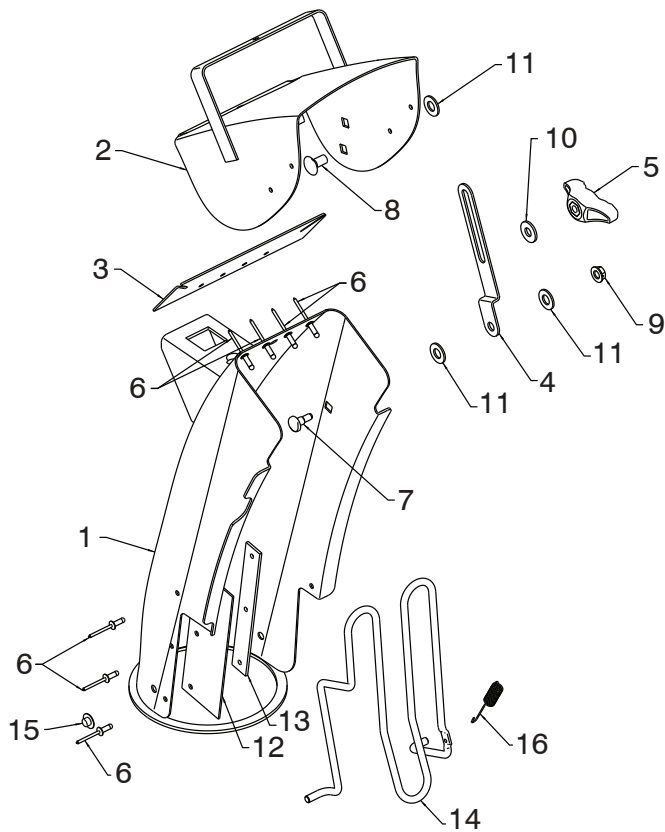

KEY NO.	PART NO.	DESCRIPTION
1	532 44 40-41	CHUTE WELDMENT
2	532 18 41-13	DEFLECTOR WELDMENT
3	532 42 03-25	DEFLECTOR SEAL
4	532 18 41-14	STRAP
5	532 19 19-38	KNOB BLACK
6	532 12 84-15	POP RIVET
7	532 18 56-00	SHOULDER BOLT 1/4-20 X .704
8	872 27 05-05	CARRIAGE BOLT 5/16-18 X .625
9	532 19 17-30	NUT 1/4-20
10	532 15 54-15	WASHER
11	532 17 92-46	PLASTIC WASHER
12	532 43 03-24	CHUTE SNOW SHIELD
13	532 42 17-28	SHIELD RETAINER STRAP
14	532 43 55-82	CHUTE GUARD
15	532 05 93-49	PUSH NUT
16	532 43 56-16	SPRING

01.09.027-B

NOTE: All component dimensions given in U.S. inches. 1 inch = 25.4 mm
IMPORTANT: Use only Original Equipment Manufacturer (O.E.M.) replacement parts.
 Failure to do so could be hazardous, damage your snow thrower and void your warranty.

REPAIR PARTS

CONTROL PANEL / DISCHARGE CHUTE

SNOW THROWER - MODEL NO. **5524ST** (96191001613), PRODUCT NO. 961 91 00 16

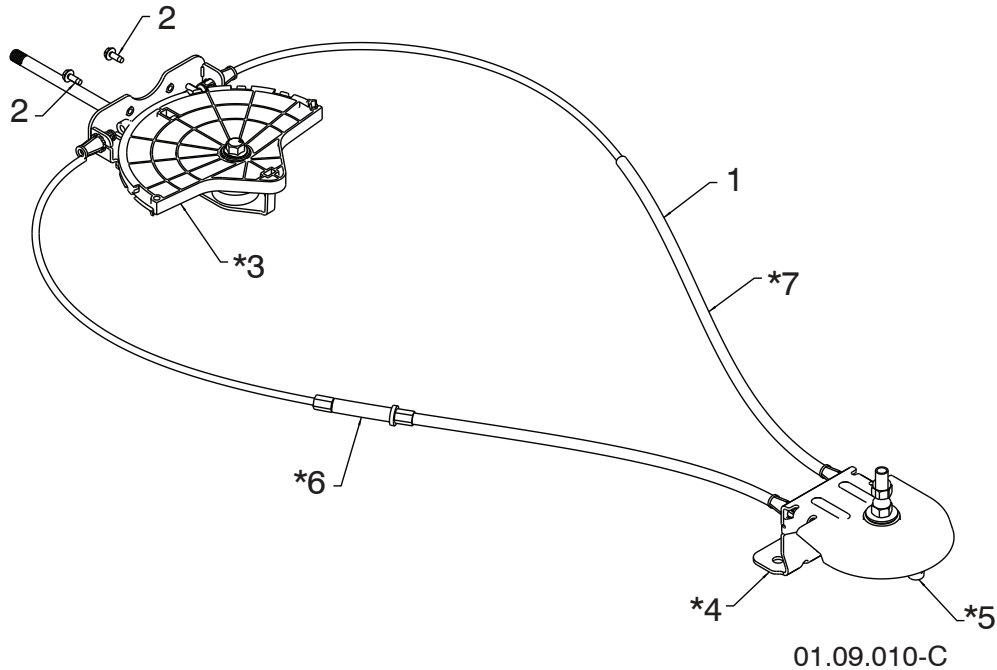

KEY NO.	PART NO.	DESCRIPTION
1	532 42 82-72	LEVER/CABLE ROTATOR ASSEMBLY
2	817 54 10-08	SCREW 10-24 X .625
*3	532 42 06-78	ROTATOR HEAD
*4	532 40 59-32	ROTATOR PIVOT BRACKET
*5	532 42 06-75	PULLEY PIVOT
*6	532 42 82-73	CABLE ASSEMBLY ADJUSTABLE
*7	532 42 83-10	CABLE ASSEMBLY HEAT SHIELD

NOTES:

1. ITEMS INDICATED WITH AN * ARE LISTED AS REFERENCE FOR SERVICE PARTS ONLY.

NOTE: All component dimensions given in U.S. inches. 1 inch = 25.4 mm
IMPORTANT: Use only Original Equipment Manufacturer (O.E.M.) replacement parts. Failure to do so could be hazardous, damage your snow thrower and void your warranty.

REPAIR PARTS

HANDLES

SNOW THROWER - MODEL NO. 5524ST (96191001613), PRODUCT NO. 961 91 00 16

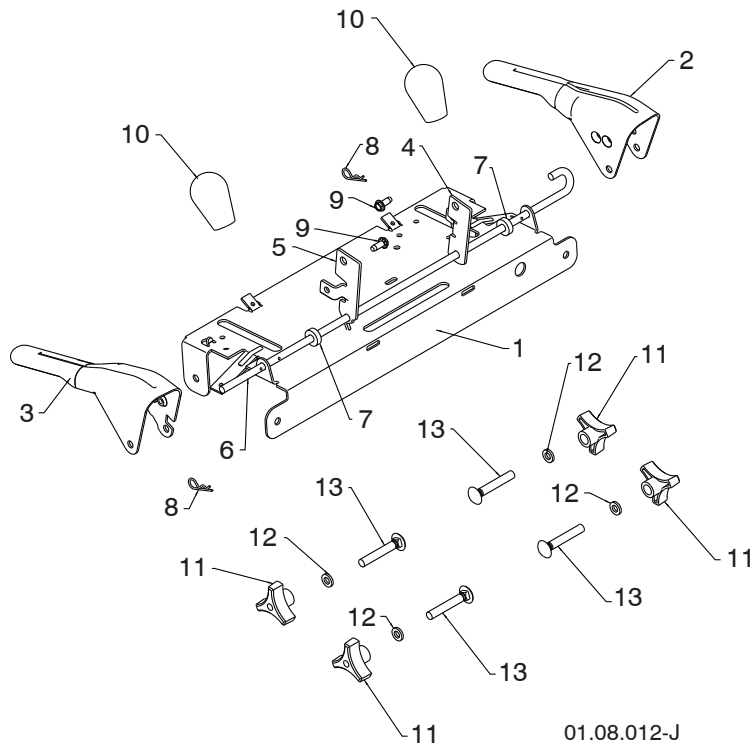

01.08.012-J

KEY NO.	PART NO.	DESCRIPTION
1	585 19 88-02	CONTROL PANEL
2	580 68 78-03	CONTROL LEVER LH
3	580 68 77-03	CONTROL LEVER RH
4	532 41 55-46	TRACTION ROD ARM
5	532 42 90-98	IMPELLER ROD ARM
6	532 41 26-77	INTERLOCK ROD
7	532 42 16-13	SPACER
8	532 16 96-75	RETAINER
9	817 06 04-10	SCREW 1/4-20 X .62
10	580 67 32-01	KNOB SOFT TOUCH
11	532 17 88-99	HANDLE KNOB
12	819 13 13-16	WASHER 3/8
13	872 12 06-18	CARRIAGE BOLT 3/8-16 X 2.25

NOTE: All component dimensions given in U.S. inches. 1 inch = 25.4 mm
IMPORTANT: Use only Original Equipment Manufacturer (O.E.M.) replacement parts. Failure to do so could be hazardous, damage your snow thrower and void your warranty.

REPAIR PARTS

HANDLES

SNOW THROWER - MODEL NO. **5524ST** (96191001613), PRODUCT NO. 961 91 00 16

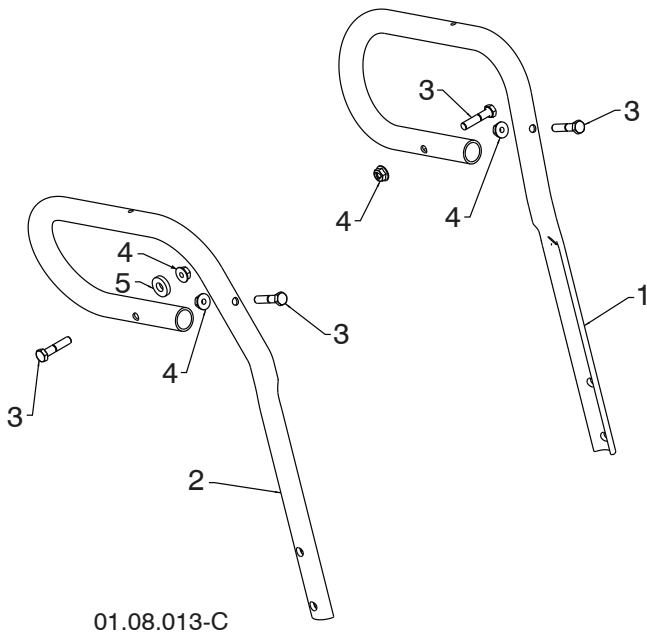

KEY NO.	PART NO.	DESCRIPTION
1	532 42 95-88	LOOP HANDLE LH
2	532 42 95-89	LOOP HANDLE RH
3	874 78 05-24	SCREW 5/16-18 X 1.50
4	532 75 11-53	NUT 5/16-18
5	532 05 56-11	WASHER

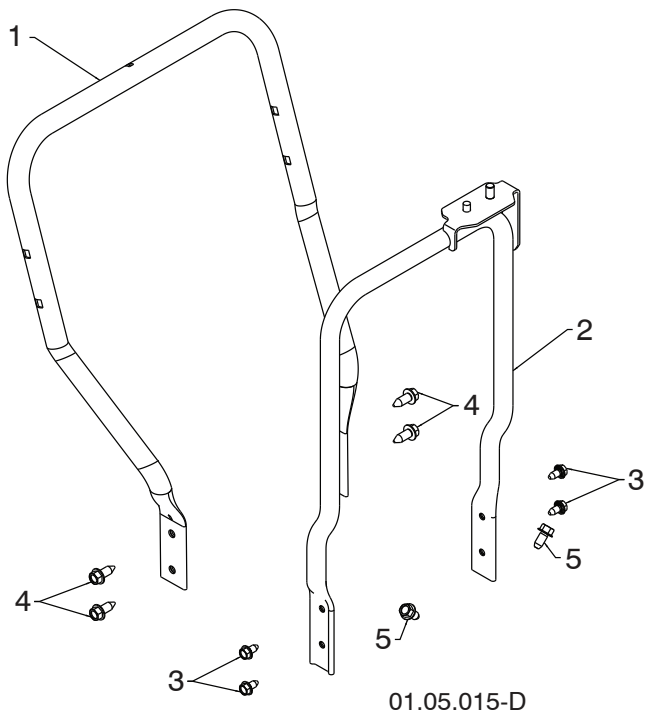

KEY NO.	PART NO.	DESCRIPTION
1	582 23 81-03	LOWER HANDLE
2	532 44 36-17	PIVOT SUPPORT WELDMENT
3	817 00 05-10	SCREW 5/16-18 X .750
4	817 00 06-16	SCREW 3/8-16 X 1.00
5	817 00 06-12	SCREW 3/8-16 X .750

NOTE: All component dimensions given in U.S. inches. 1 inch = 25.4 mm
IMPORTANT: Use only Original Equipment Manufacturer (O.E.M.) replacement parts.
 Failure to do so could be hazardous, damage your snow thrower and void your warranty.

REPAIR PARTS

HANDLES

SNOW THROWER - MODEL NO. 5524ST (96191001613), PRODUCT NO. 961 91 00 16

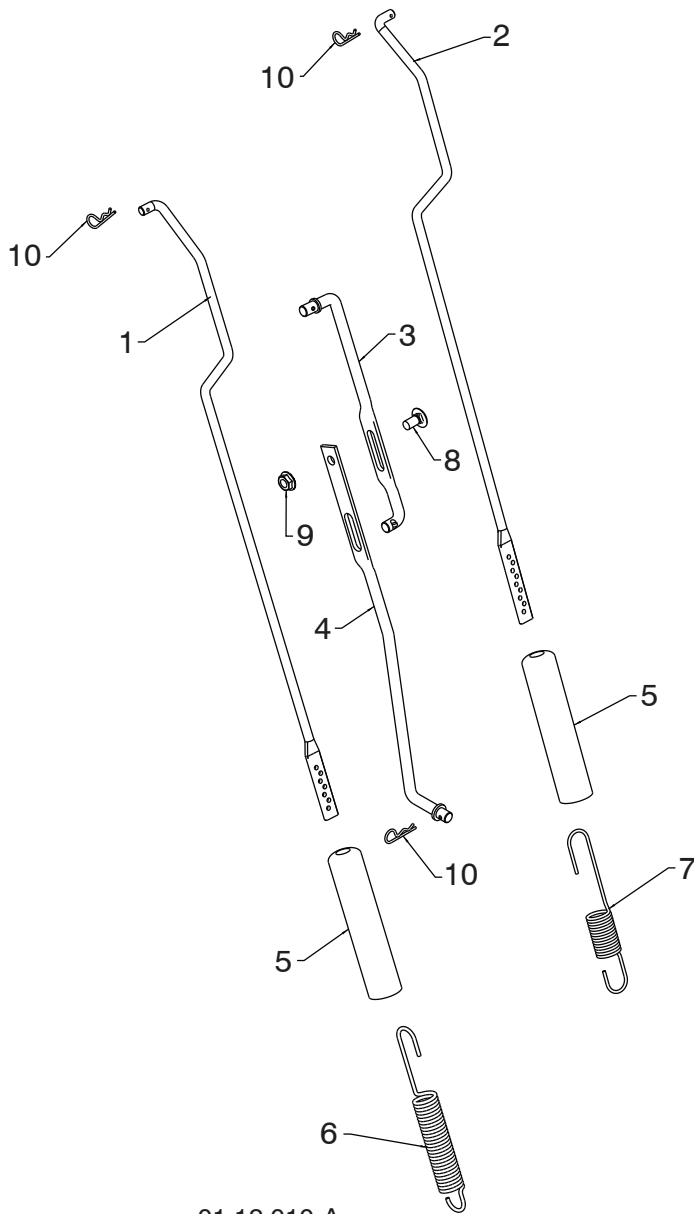

KEY NO.	PART NO.	DESCRIPTION
1	580 79 77-01	IMPELLER ROD ASSEMBLY
2	580 79 79-01	TRACTION ROD ASSEMBLY
3	532 18 04-45	SHIFTER ROD TOP
4	532 18 77-16	SHIFTER ROD BOTTOM
5	532 18 04-47	SPRING SLEEVE
6	580 79 62-01	SPRING CONTROL ROD
7	580 80 21-01	SPRING TRACTION ROD
8	872 27 05-05	CARRIAGE BOLT 5/16-18 X .750
9	532 15 53-77	NUT 5/16-18
10	532 16 96-75	RETAINER

01.12.010-A

NOTE: All component dimensions given in U.S. inches. 1 inch = 25.4 mm
IMPORTANT: Use only Original Equipment Manufacturer (O.E.M.) replacement parts.
Failure to do so could be hazardous, damage your snow thrower and void your warranty.

REPAIR PARTS

HANDLES

SNOW THROWER - MODEL NO. **5524ST** (96191001613), PRODUCT NO. 961 91 00 16

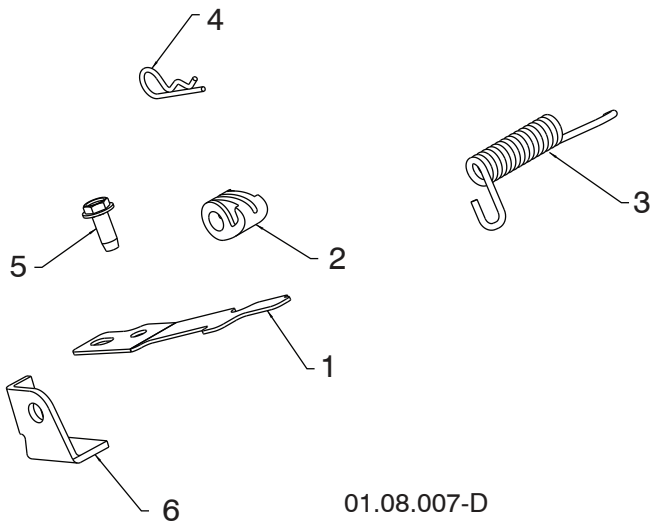

01.08.007-D

KEY NO.	PART NO.	DESCRIPTION
1	532 41 62-88	INTERLOCK SPRING
2	532 44 52-91	INTERLOCK CAM
3	532 44 32-15	TORSION SPRING
4	532 16 96-75	RETAINER
5	817 06 04-10	SCREW 1/4-20 X .625
6	532 42 18-14	INTERLOCK STOP

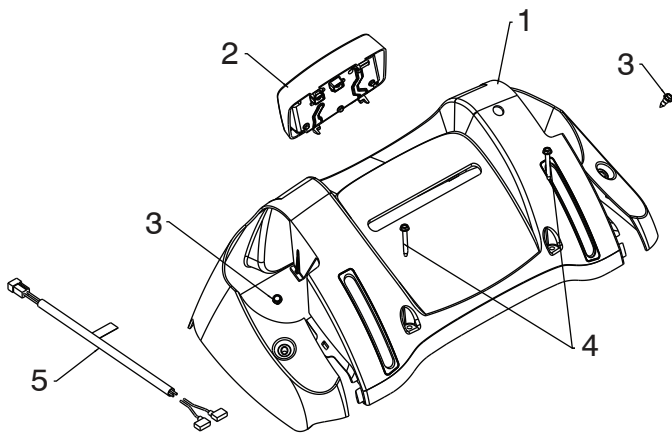

01.10.054-A

KEY NO.	PART NO.	DESCRIPTION
1	532 42 13-81	CONSOLE PANEL
2	581 68 42-01	LED LIGHT
3	532 18 44-71	SHOULDER SCREW 10-24 X .625
4	532 17 52-62	SCREW 10-24 X 1.25
5	532 44 50-29	WIRE HARNESS

NOTE: All component dimensions given in U.S. inches. 1 inch = 25.4 mm
IMPORTANT: Use only Original Equipment Manufacturer (O.E.M.) replacement parts.
 Failure to do so could be hazardous, damage your snow thrower and void your warranty.

REPAIR PARTS

DRIVE

SNOW THROWER - MODEL NO. 5524ST (96191001613), PRODUCT NO. 961 91 00 16

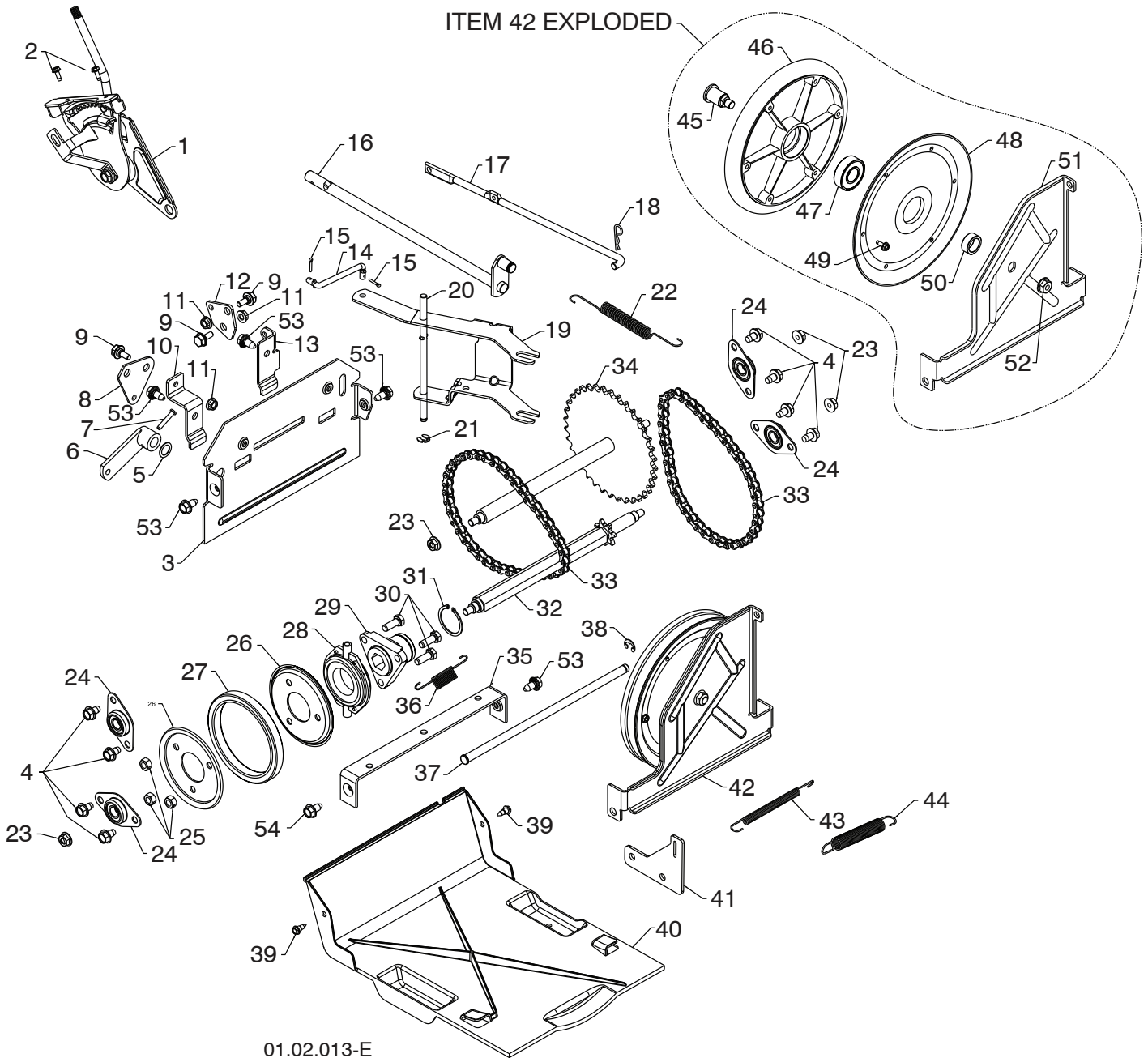

NOTE: All component dimensions given in U.S. inches. 1 inch = 25.4 mm
IMPORTANT: Use only Original Equipment Manufacturer (O.E.M.) replacement parts.
Failure to do so could be hazardous, damage your snow thrower and void your warranty.

REPAIR PARTS**DRIVE****SNOW THROWER - MODEL NO. 5524ST (96191001613), PRODUCT NO. 961 91 00 16**

KEY NO.	PART NO.	DESCRIPTION	KEY NO.	PART NO.	DESCRIPTION
1	532 19 88-75	SPEED SELECTOR ASSEMBLY	28	532 17 53-44	BEARING
2	817 54 10-08	SCREW 10-24 X .625	29	532 17 86-13	WHEEL HUB
3	532 43 60-80	END PLATE	30	874 76 05-14	SCREW 5/16-18-.875
4	817 49 05-08	SCREW 5/16-18 X .50	31	812 00 00-12	RETAINER RING
5	532 05 70-79	WASHER	32	532 40 21-87	SPROCKET SHAFT
6	532 40 54-85	CONTROL ARM	33	532 40 16-19	CHAIN
7	532 19 85-80	CLEVIS PIN	34	532 43 73-03	SPROCKET WELDMENT
8	532 41 54-50	SHIFTER PLATE	35	532 41 54-29	SHIFTER BRACKET
9	532 40 28-81	SHOULDER BOLT	36	532 18 01-35	SPRING
10	532 41 54-33	SHIFTER BRACKET	37	532 40 26-52	PLATE PIVOT ROD
11	532 19 17-30	NUT 1/4-20	38	532 42 82-88	E-RING .375
12	532 41 54-35	CLUTCH PLATE	39	532 18 44-71	SHOULDER SCREW
13	532 41 68-64	CLUTCH BRACKET	40	532 41 08-77	BOTTOM PAN
14	532 18 71-01	SHIFTER LINK	41	532 41 66-82	SPRING BRACKET
15	532 70 02-79	RETAINER	42	532 40 26-89	DRIVE PLATE ASSEMBLY
16	532 42 75-42	CONTROL SHAFT	43	532 41 45-57	IDLER SPRING
17	532 40 25-68	CLUTCH ROD	44	532 17 88-28	IDLER SPRING
18	532 16 96-75	RETAINER	45	532 40 25-04	PULLEY SHAFT
19	581 42 25-01	SHIFTER YOKE	46	532 40 18-20	DRIVE PLATE
20	532 40 23-10	PIVOT ROD	47	532 19 87-91	BEARING
21	812 00 00-36	RETAINER	48	532 40 23-93	PULLEY HALF
22	532 40 28-78	RETURN SPRING	49	817 54 10-08	SCREW 10-24 X .50
23	532 75 11-53	NUT 5/16-18	50	532 40 25-11	SPACER BEARING
24	532 40 89-81	BEARING	51	532 42 29-41	SWING PLATE
25	873 93 05-00	NUT 5/16-18	52	532 13 20-10	NUT 3/8-16
26	532 19 95-09	RUBBER WHEEL PLATE	53	532 42 88-67	SCREW 5/16-18 X .750
27	585 02 10-01	RUBBER RING	54	817 00 05-10	BOLT 5/16-18 X .625

NOTE: All component dimensions given in U.S. inches. 1 inch = 25.4 mm

IMPORTANT: Use only Original Equipment Manufacturer (O.E.M.) replacement parts. Failure to do so could be hazardous, damage your snow thrower and void your warranty.

REPAIR PARTS

DRIVE

SNOW THROWER - MODEL NO. **5524ST** (96191001613), PRODUCT NO. 961 91 00 16

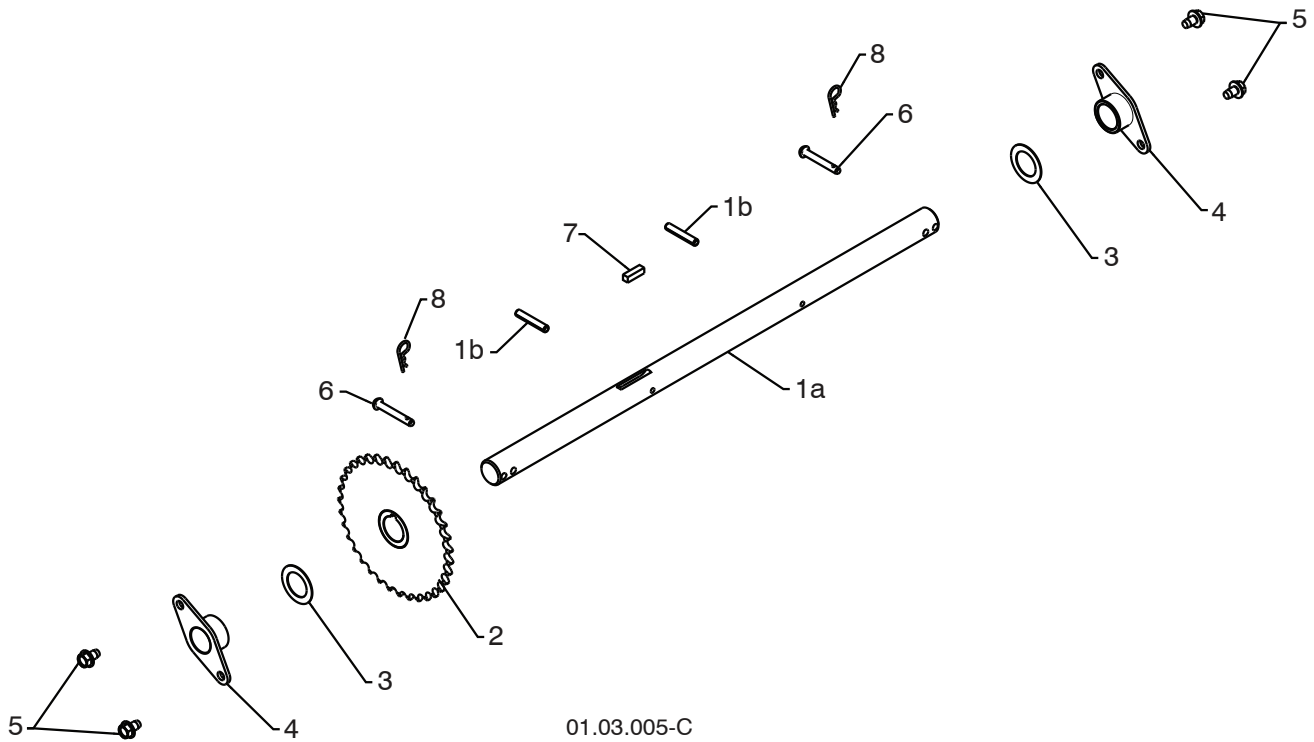

KEY NO.	PART NO.	DESCRIPTION
1	532 18 82-26	AXLE ASSEMBLY (assy of 1a,1b)
1a	532 17 93-52	AXLE SHAFT
1b	532 18 42-06	ROLL PIN 3/16
2	532 40 26-91	SPROCKET
3	532 44 49-49	THRUST WASHER
4	532 17 98-30	BEARING
5	817 49 05-08	BOLT 5/16-18 X .500
6	532 17 12-71	PIN
7	532 18 92-82	SQUARE KEY
8	532 12 47-88	RETAINER PIN

NOTE: All component dimensions given in U.S. inches. 1 inch = 25.4 mm
IMPORTANT: Use only Original Equipment Manufacturer (O.E.M.) replacement parts.
Failure to do so could be hazardous, damage your snow thrower and void your warranty.

REPAIR PARTS

CHASSIS / PULLEYS

SNOW THROWER - MODEL NO. 5524ST (96191001613), PRODUCT NO. 961 91 00 16

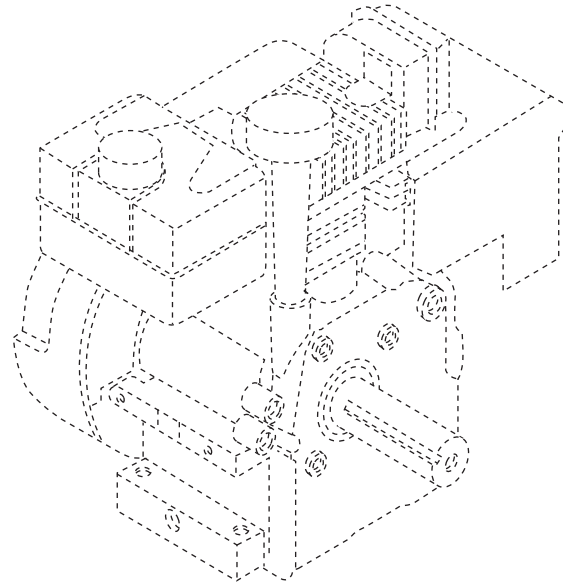
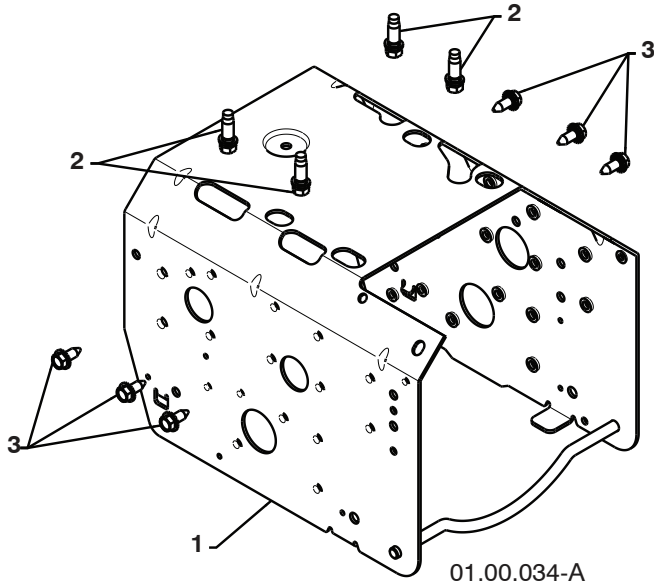

KEY NO.	PART NO.	DESCRIPTION
--	---	B&S ENGINE 12A106-0165-F8
1	532 43 59-52	FRAME
2	532 15 04-06	BOLT 3/8-16
3	532 42 88-67	SCREW 5/16-18 X .750

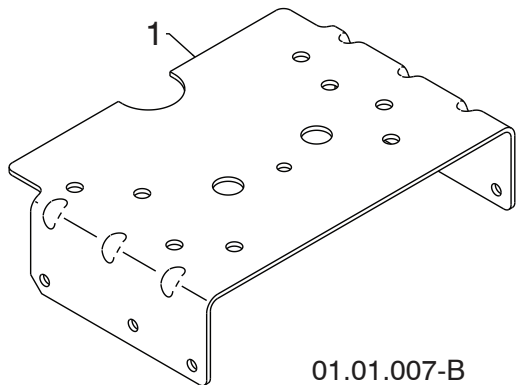

KEY NO.	PART NO.	DESCRIPTION
1	532 43 63-11	ENGINE MOUNT PLATE

NOTE: All component dimensions given in U.S. inches. 1 inch = 25.4 mm
IMPORTANT: Use only Original Equipment Manufacturer (O.E.M.) replacement parts. Failure to do so could be hazardous, damage your snow thrower and void your warranty.

REPAIR PARTS

CHASSIS / PULLEYS

SNOW THROWER - MODEL NO. 5524ST (96191001613), PRODUCT NO. 961 91 00 16

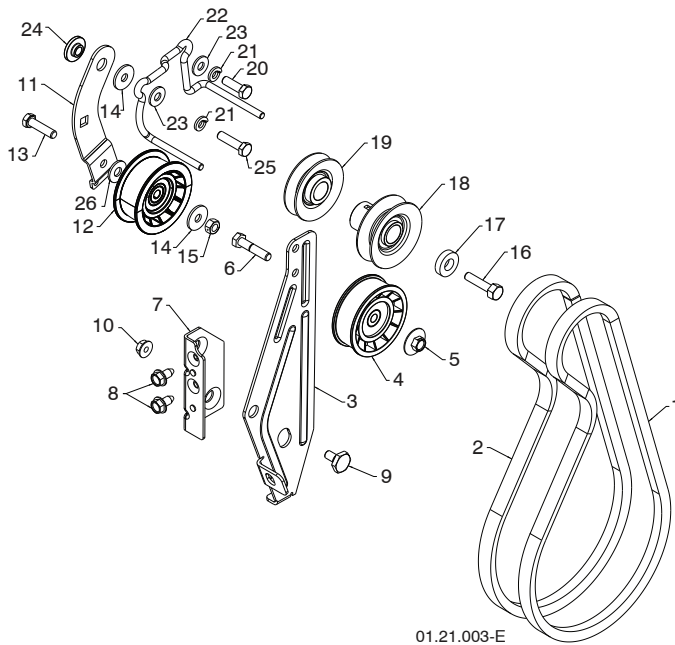

KEY NO.	PART NO.	DESCRIPTION
1	532 43 07-83	IMPELLER BELT
2	532 41 97-44	TRACTION BELT
3	584 23 24-02	IDLER ARM BRACKET
4	532 18 05-23	IDLER PULLEY
5	532 42 65-89	NUT 5/16-18
6	874 78 05-24	CAPSCREW 5/16-18 X 1.50
7	585 28 49-01	IDLER BRACKET
8	817 00 05-10	SCREW 5/16-18 X 1.50
9	532 42 42-97	SHOULDER BOLT 5/16-18 X .500
10	532 75 11-53	NUT 5/16-18 TOP LOCK
11	532 18 77-86	TRACTION IDLER ARM
12	585 07 03-01	TRACTION PULLEY
13	874 78 05-20	CAPSCREW 5/16-18 X 1.00
14	532 05 92-89	WASHER
15	873 93 05-00	NUT 5/16-18
16	532 85 10-84	CAPSCREW 3/8-24 X 1.375
17	532 40 00-26	WASHER
18	532 42 64-91	PULLEY ENG IMPELLER
19	532 42 64-90	PULLEY ENG TRACTION
20	874 61 05-16	CAPSCREW HEX HEAD 5/16 X 1.25 GR5
21	810 04 05-00	LOCKWASHER 5/16
22	585 05 82-01	BELT GUIDE
23	532 15 54-15	WASHER
24	532 17 53-31	IDLER BUSHING
25	874 61 05-20	CAPSCREW 5/16-18 X 1.25
26	539 99 06-92	WASHER FLAT 5/16 X .88

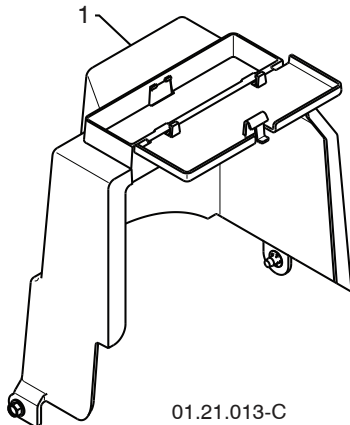

KEY NO.	PART NO.	DESCRIPTION
1	532 44 30-30	COVER ASSEMBLY

NOTE: All component dimensions given in U.S. inches. 1 inch = 25.4 mm

IMPORTANT: Use only Original Equipment Manufacturer (O.E.M.) replacement parts. Failure to do so could be hazardous, damage your snow thrower and void your warranty.

REPAIR PARTS

WHEELS

SNOW THROWER - MODEL NO. **5524ST** (96191001613), PRODUCT NO. 961 91 00 16

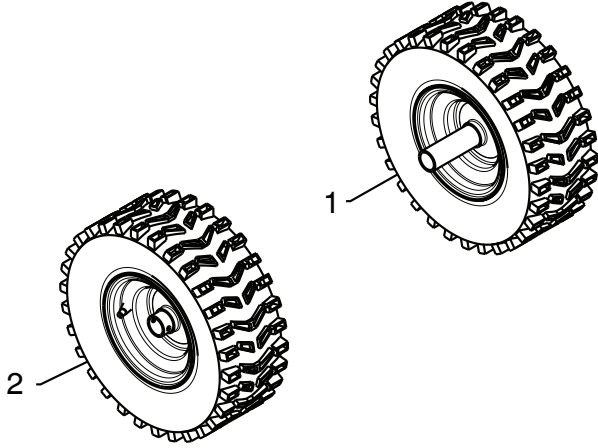

01.06.010-A

KEY NO.	PART NO.	DESCRIPTION
1	532 43 65-15	WHEEL 16 X 4.80 X LH
2	532 43 65-16	WHEEL 16 X 4.80 X RH

NOTE: All component dimensions given in U.S. inches. 1 inch = 25.4 mm
IMPORTANT: Use only Original Equipment Manufacturer (O.E.M.) replacement parts.
Failure to do so could be hazardous, damage your snow thrower and void your warranty.

REPAIR PARTS

BAG OF PARTS

SNOW THROWER - MODEL NO. 5524ST (96191001613), PRODUCT NO. 961 91 00 16

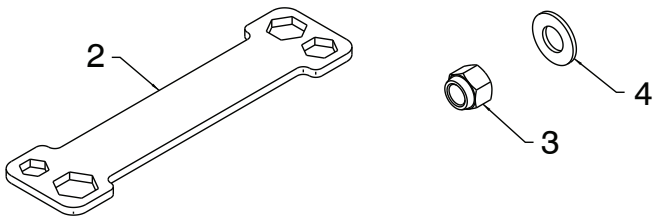

KEY NO.	PART NO.	DESCRIPTION
1	532 16 96-75	RETAINER PIN
2	532 42 91-12	WRENCH
3	873 80 06-00	LOCKNUT 3/8-16
4	819 13 13-16	WASHER 3/8
5	532 19 20-90	SHEAR BOLT 1/4-20 X 1-13/16
6	873 80 04-00	LOCKNUT 1/4-20

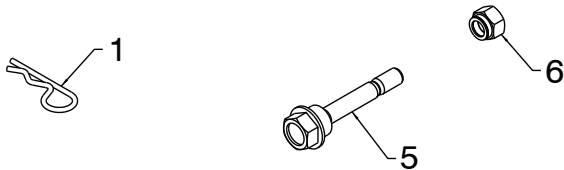

01.14.006-B

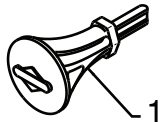

01.14.007-A

KEY NO.	PART NO.	DESCRIPTION
1	532 19 30-71	SAFETY IGNITION KEY

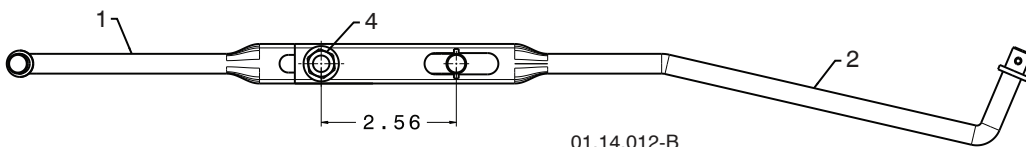
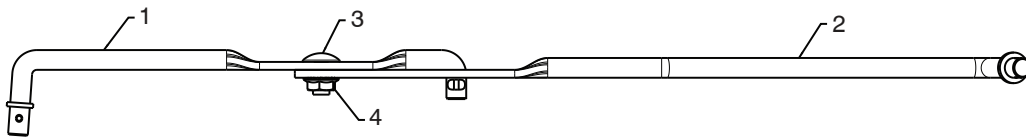

01.14.012-B

KEY NO.	PART NO.	DESCRIPTION
1	532 18 04-45	SHIFTER ROD TOP
2	532 18 77-16	SHIFTER ROD BOTTOM
3	872 27 05-05	CARRIAGE BOLT 5/16-18 X .75
4	532 15 53-77	NUT 5/16-18

NOTE: All component dimensions given in U.S. inches. 1 inch = 25.4 mm
IMPORTANT: Use only Original Equipment Manufacturer (O.E.M.) replacement parts. Failure to do so could be hazardous, damage your snow thrower and void your warranty.

REPAIR PARTS

DECALS

SNOW THROWER - MODEL NO. **5524ST** (96191001613), PRODUCT NO. 961 91 00 16

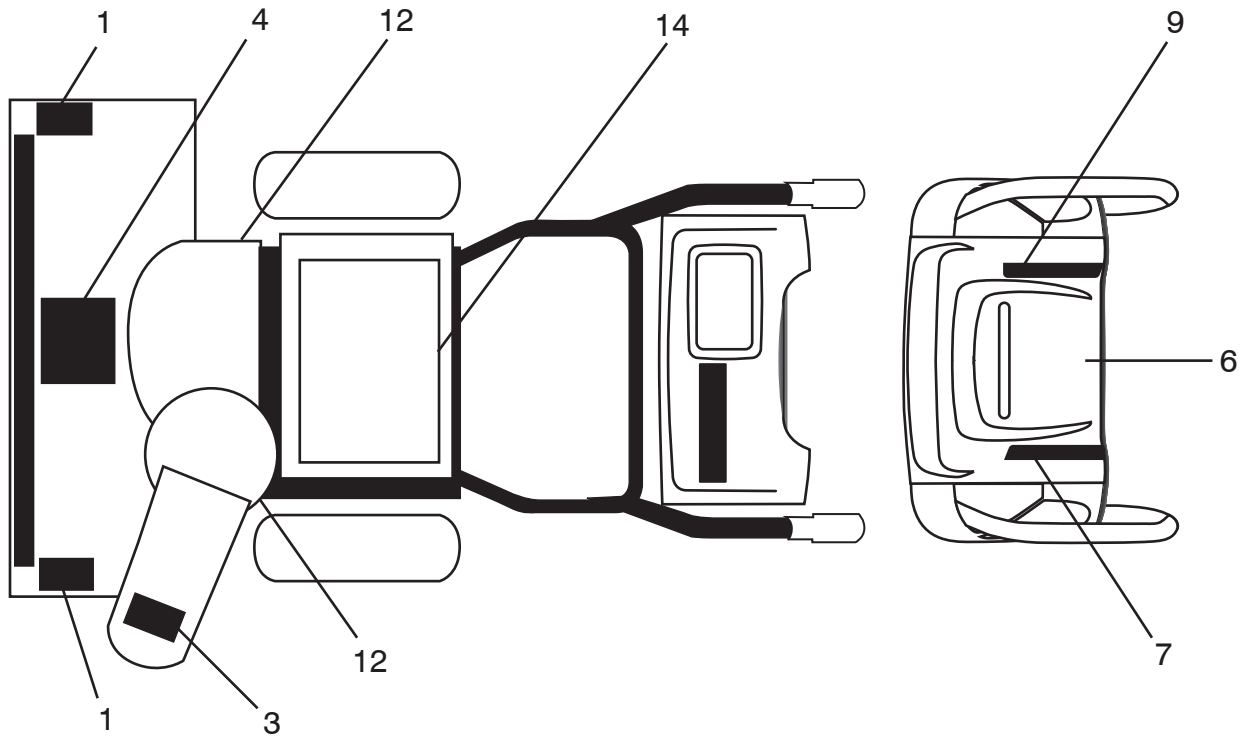

KEY NO.	PART NO.	DESCRIPTION
1	532 19 96-83	DECAL, DANGER
3	532 19 96-82	DECAL, DANGER, DEFLECTOR
4	532 18 40-45	DECAL, DANGER
6	532 42 95-75	DECAL, INSTRUCTION
7	581 43 01-05	DECAL, CONS. LT. WO/DEFL.GRY
9	581 43 01-04	DECAL, CONS. RT. SPD/LRV/PWST/GRY
12	532 18 40-28	DECAL, BELT GUARD
14	532 18 04-33	DECAL, SOUND LEVEL
--	532 44 31-06	OPERATOR'S MANUAL, EURO
--	532 44 31-07	OPERATOR'S MANUAL, SCAND
--	532 44 31-10	OPERATOR'S MANUAL, EAST BLOC
--	532 44 31-08	OPERATOR'S MANUAL, BALTIC

NOTE: All component dimensions given in U.S. inches. 1 inch = 25.4 mm

IMPORTANT: Use only Original Equipment Manufacturer (O.E.M.) replacement parts. Failure to do so could be hazardous, damage your snow thrower and void your warranty.

