

ILLUSTRATED PARTS LIST

MODEL NO. 96051012000

CUSTOMER CATALOG NO. CTH2138R

PRODUCT NO. 960 51 01-20

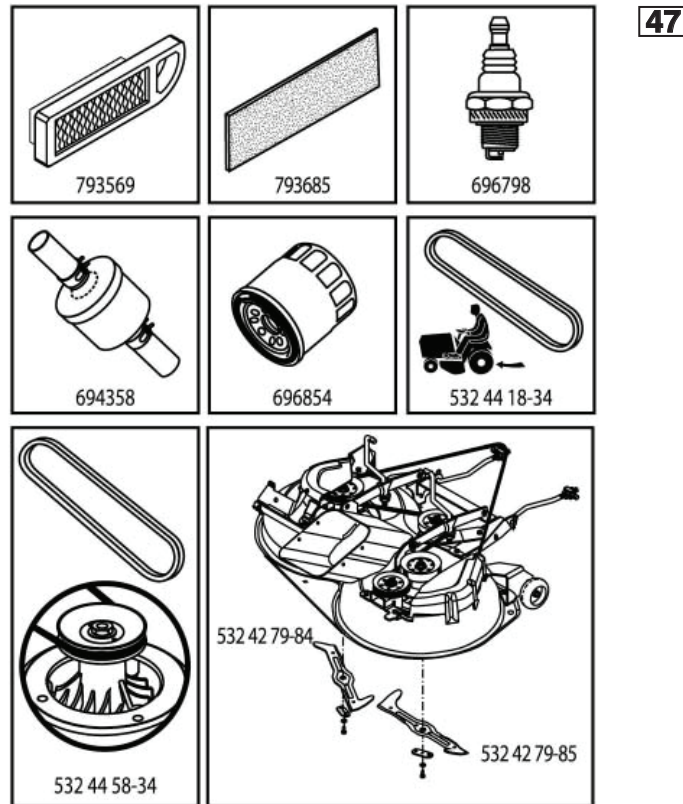

448538

TRACTOR - MODEL NO. CTH2138R (96051012000), PRODUCT NO. 96051 01-20
DECALS 27

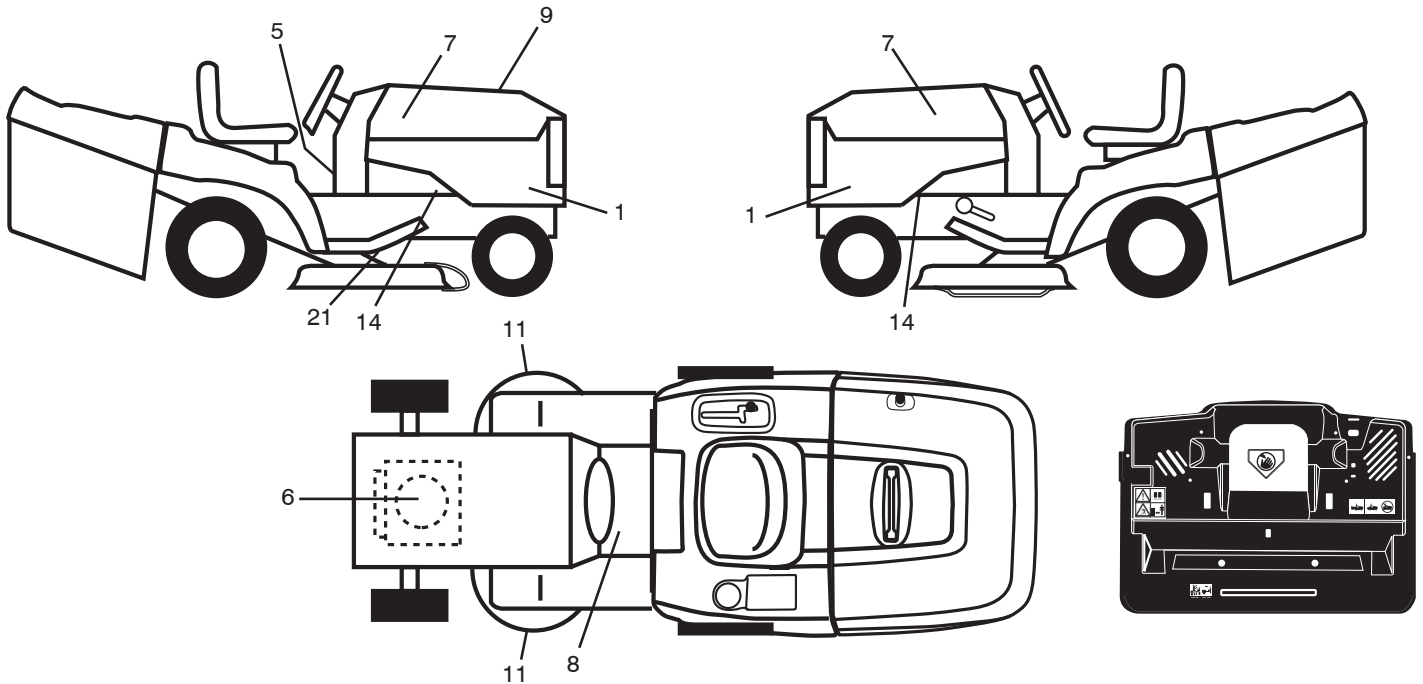

KEY NO.	PART NO.	DESCRIPTION
1	532 44 85-47	Decal, Side Panel
5	581 57 84-01	Decal, Inst
6	581 57 97-01	Decal, Warning Engine Symbols
7	581 62 73-01	Decal, Hood RH/LH
8	581 57 83-01	Decal, Warning
9	532 44 85-38	Decal, RPL
11	581 57 91-01	Decal, Mower Cut Finger Symbol

KEY NO.	PART NO.	DESCRIPTION
14	581 57 96-01	Decal, Chassis Hot Muffler
21	532 44 11-89	Decal, Deck Belt Sch
--	581 42 48-01	Decal, Bypass
--	532 44 27-44	Decal, Battery Door
--	532 44 14-09	Pad Footrest LH
--	532 44 14-10	Pad Footrest RH
--	585 26 32-26	Manual Operators (English)

WHEELS & TIRES

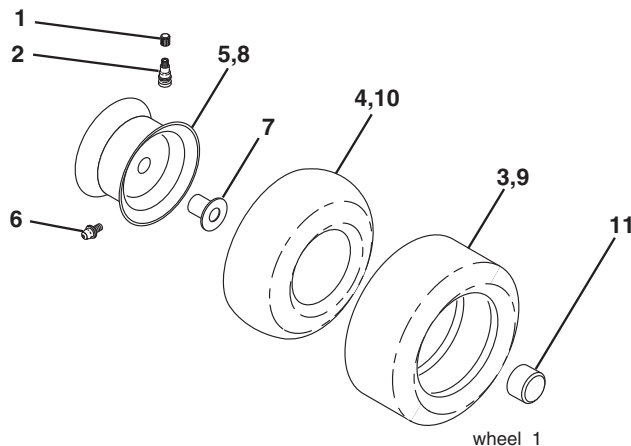

KEY NO.	PART NO.	DESCRIPTION
1	532 05 91-92	Cap Valve Tire
2	532 06 51-39	Stem Valve
3	532 10 62-22	Tire F Ts 15 x 6 0 - 6 Service
4	532 05 99-04	Tube Inner Front #35060
5	532 13 83-36	Rim Asm 6" Front Service
6	532 12 49-57	Fitting Grease
7	532 12 49-59	Bearing Flange
8	532 13 83-37	Rim Asm 8" Rear Service
9	532 42 05-31	Tire R Ts 20 x 10-8 Service
10	532 12 49-26	Tube Rear 9 5 x 8 Service
11	532 17 50-39	Cap Axle Blk 1 50 x 1 00
--	532 14 43-34	Sealant, Tire (10 oz. tube)

NOTE: All component dimensions given in U.S. inches.
 1 inch = 25.4 mm

TRACTOR - MODEL NO. CTH2138R (96051012000), PRODUCT NO. 9605101-20

SCHEMATIC **38**

SCH19

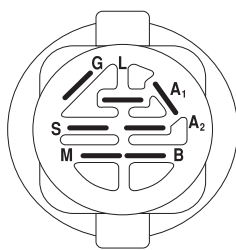
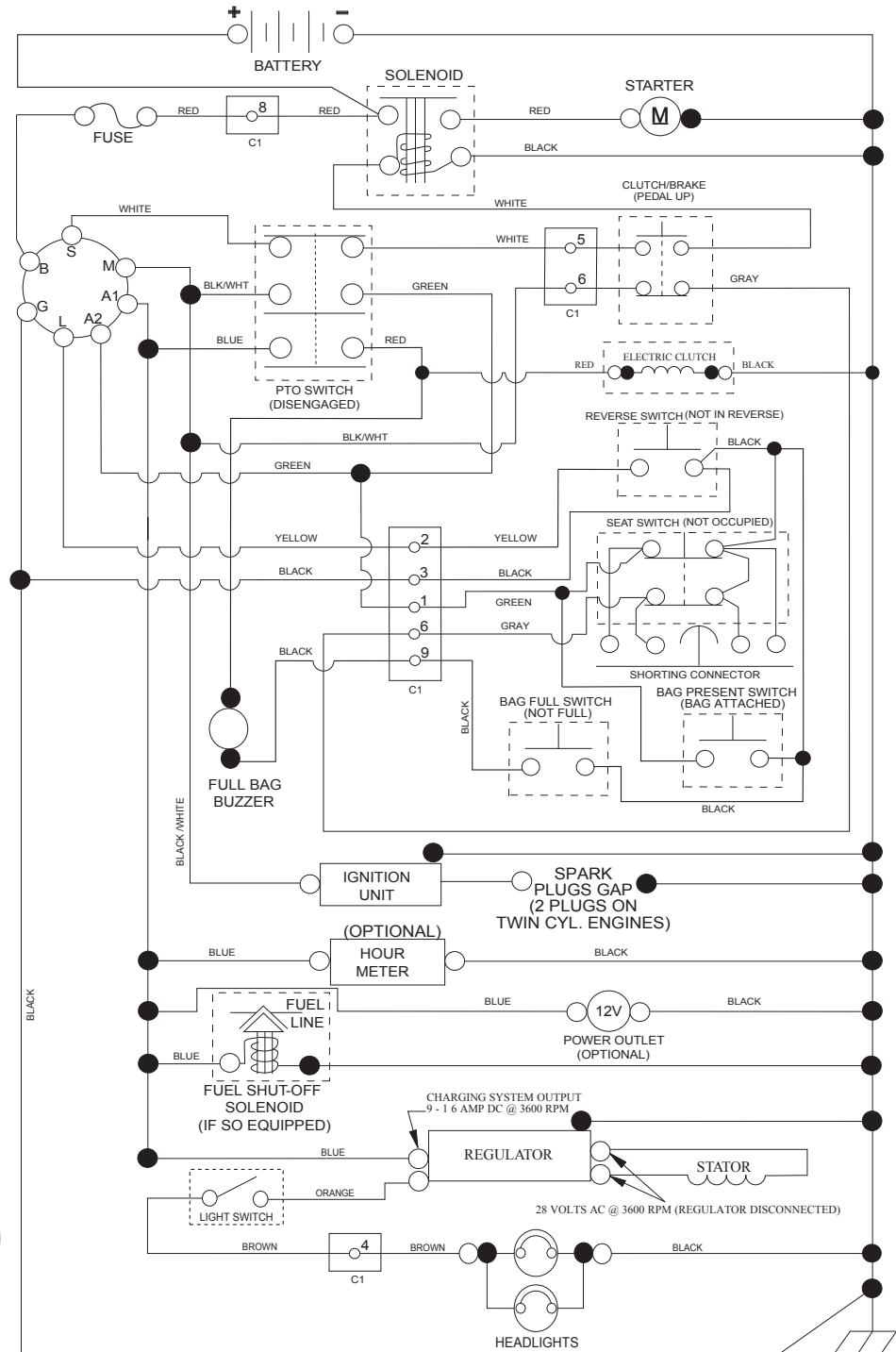

POSITION	CIRCUIT	"MAKE"
OFF	M+G+A1	
RUN/OVERRIDE	B+A1	
RUN	B+A1	L+A2
START	B + S + A1	

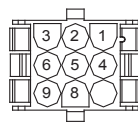
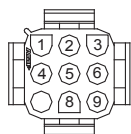

WIRING INSULATED CLIPS
NOTE: IF WIRING INSULATED CLIPS WERE REMOVED FOR SERVICING OF UNIT, THEY SHOULD BE RE-INSTALLED TO PROPERLY SECURE YOUR WIRING.

NON-REMOVABLE CONNECTIONS

REMOVABLE CONNECTIONS

TRACTOR - MODEL NO. CTH2138R (96051012000), PRODUCT NO. 96051 01-20
ELECTRICAL 32

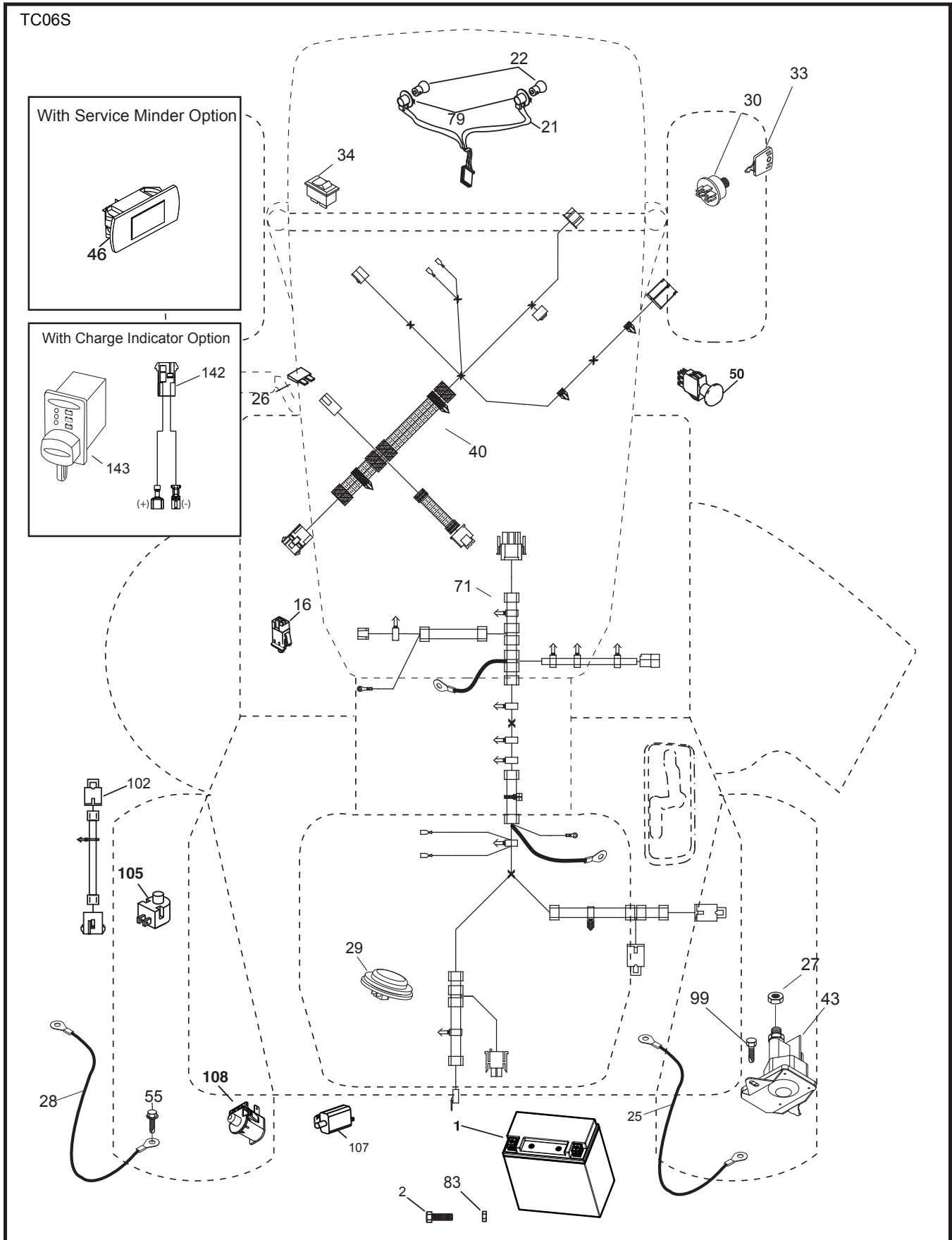

TRACTOR - MODEL NO. CTH2138R (96051012000), PRODUCT NO. 9605101-20
ELECTRICAL 32

KEY NO.	PART NO.	DESCRIPTION
1	532 43 71-57	Battery
2	532 44 09-23	Screw Hex Head Cap M6 x 1.12 mm
16	532 17 61-38	Switch Interlock Push-In
21	532 40 02-52	Harness Socket Light w/4152J
22	532 00 41-52	Bulb Light
25	581 48 98-01	Cable Starter
26	532 17 51-58	Fuse
27	873 51 04-00	Nut Keps Hex 1/4-20 unc
28	581 48 98-02	Cable, Ground
29	532 40 15-45	Switch, Seat
30	532 19 33-50	Switch, Ign.
33	532 41 19-33	Key/Chain
34	532 11 07-12	Switch Light/Reset
40	532 42 95-33	Harness Dash
43	532 19 25-07	Solenoid
46	532 40 17-63	Guage SRVCMNDR
50	532 17 46-51	Switch PTO
55	817 06 05-12	Screw Thdrol. 5/16-18 x 3/4 TYTT
71	532 44 08-20	Harness Chassis
79	532 17 52-42	Socket Asm. Bulb Twistlock
83	532 43 67-74	Nut Square M6 x 1.8.5 x 11 mm
99	817 72 04-08	Screw 1/4-20 x 1/2
102	532 44 12-62	Harness Pigtail Tex ROS Tuff Torq
105	532 40 75-68	Switch Reverse
107	532 18 03-79	Switch Full Bagger Indicator
108	532 42 10-62	Switch Snapmount

NOTE: All component dimensions given in U.S. inches
1 inch = 25.4 mm

TRACTOR - MODEL NO. CTH2138R (96051012000), PRODUCT NO. 96051 01-20
CHASSIS AND ENCLOSURES 39

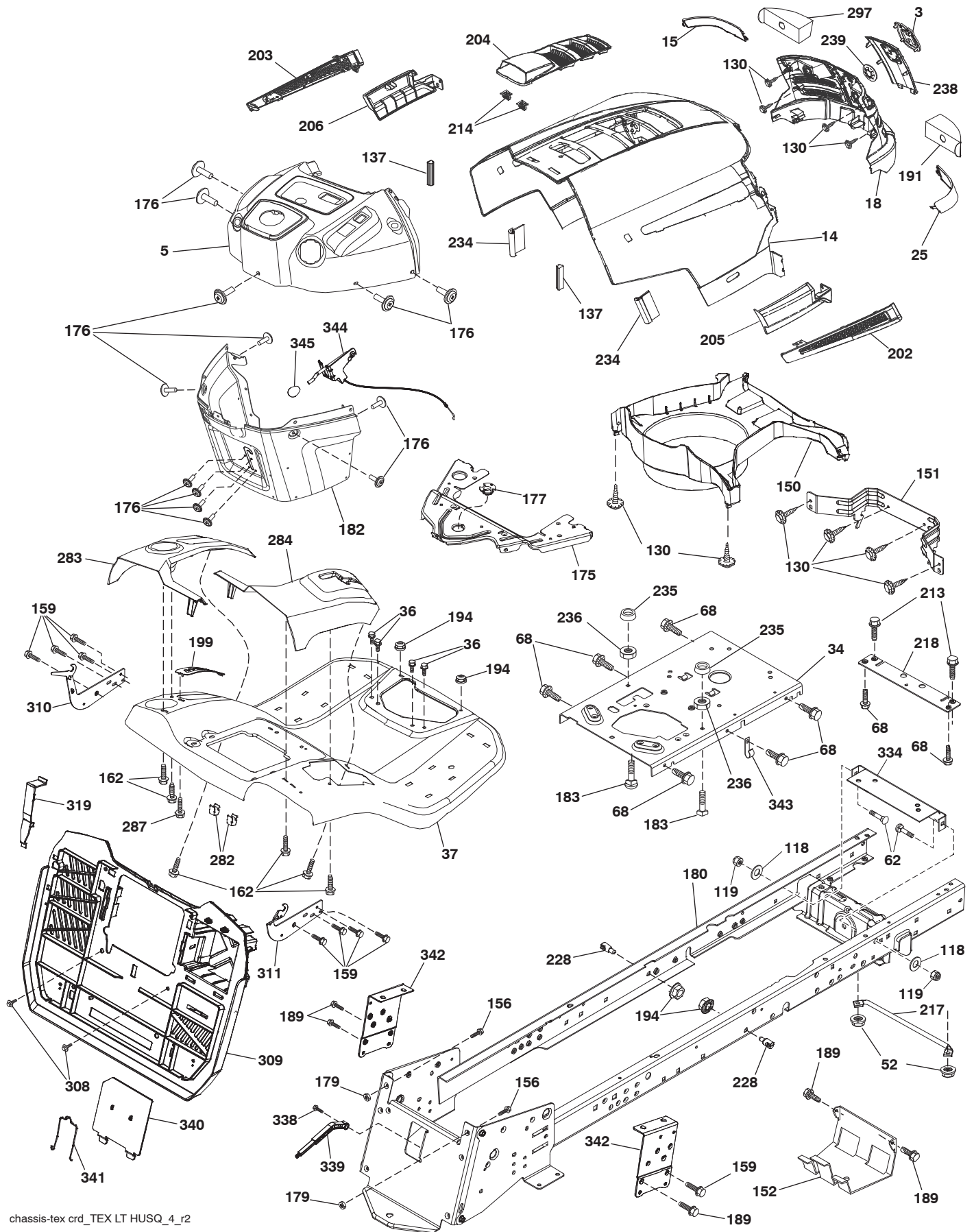

chassis-tex crd_TEX LT HUSQ_4_r2

**TRACTOR - MODEL NO. CTH2138R (96051012000), PRODUCT NO. 960 51 01-20
CHASSIS AND ENCLOSURES 39**

KEY NO.	PART NO.	DESCRIPTION	KEY NO.	PART NO.	DESCRIPTION
3	581 05 63-01	Logo	206	532 44 13-45	Skirt Side LH
5	532 43 89-66	Dash	213	874 76 05-12	Bolt Hex HD 5/16-18 unc 3/4
14	532 44 12-67	Hood	214	532 19 91-45	Clip Retainer
15	532 44 14-28	Lens LH	217	532 40 91-67	Rod Pivot Hood
18	532 44 13-68	Grille	218	532 19 63-95	X-Piece Hood Stop
25	532 44 14-27	Lens RH	228	532 19 51-61	Stud Fastener
34	580 91 09-01	Plate Engine	234	532 40 47-42	Bumper Hood
36	817 06 05-12	Screw 5/16-18 x 3/4	235	532 40 61-29	Spacer Fender
37	532 44 14-19	Fender	236	873 93 05 00	Nut Center Lock 5/16-18 unc
52	873 68 05-00	Nut Crownlock 5/16-18	238	532 44 13-74	Trim
62	872 11 06-08	Bolt 3/8-16 x 1 Gr. 5	239	532 40 48-83	Clip Tinnerman
68	817 49 05-08	Screw Thdrol. 5/16-18 x 1/2	282	532 41 41-10	Clip Retainer
118	819 13 13-16	Washer 12/32 x 13/16 x 16 Ga.	283	532 44 05-31	Console Deck Lift
119	873 68 06-00	Nut 3/8-16 unc	284	532 44 05-30	Console Shift RH
130	532 41 63-58	Screw #10 x .750 BOS Thread	287	817 60 04-06	Screw Hex Washhead. 1/4-20 x 3/8
137	532 40 75-90	Bumper Dash	297	532 40 66-65	Insert Reflective LH
150	532 40 66-62	Air Duct	308	532 17 18-77	Bolt 5/16-18 unc x 3/4
151	532 40 78-07	Bracket Pivot	309	584 44 11-01	Backplate
152	532 19 95-35	Shield Browning	310	532 44 66-36	Bracket Hangbar Bag LH
156	872 14 06-14	Bolt 3/8-16 unc x 1-3/4	311	532 44 66-37	Bracket Hangbar Bag RH
159	817 00 06-12	Screw 3/8-16 x 3/4	319	532 17 46-62	Bracket Actuator Bagger
162	532 14 24-32	Screw Hex Wsh. Hi-Lo 1/4 x 1/2 unc	334	532 44 25-37	Bracket Engine
175	532 19 94-72	Crossmember	338	532 43 66-40	Bolt Shoulder
176	532 40 07-76	Screw 10-24 x 5/8	339	532 43 66-41	Lever Bagger Full
177	532 19 52-28	Bushing Steering	340	532 44 09-31	Door Battery Tray
179	532 16 89-37	Nut Push	341	532 43 66-38	Latch Batter Tray
180	581 18 71-01	Chassis	342	532 43 59-38	Support Fender
182	532 43 67-76	Dash Lower	343	532 44 07-49	Clip
183	874 52 05-20	Bolt 5/16-18 x 1-1/4	344	532 43 89-70	Control EZ Mulch
189	817 00 05-12	Screw 5/16-18 x 3/4	345	532 44 06-39	Knob Oval
191	532 41 65-01	Insert Reflective RH	- -	532 40 09-44	Bumper
194	873 90 05-00	Nut Lock Hex Flange 5/16-18			
199	532 41 87-39	Plate Deck Lift			
202	532 44 13-42	Vent Side Hood RH			
203	532 44 13-43	Vent Side Hood LH			
204	532 44 13-75	Vent Top Hood			
205	532 44 13-44	Skirt Side RH			

NOTE: All component dimensions given in U.S. inches
1 inch = 25.4 mm

TRACTOR - MODEL NO. CTH2138R (96051012000), PRODUCT NO. 96051 01-20
DRIVE 40

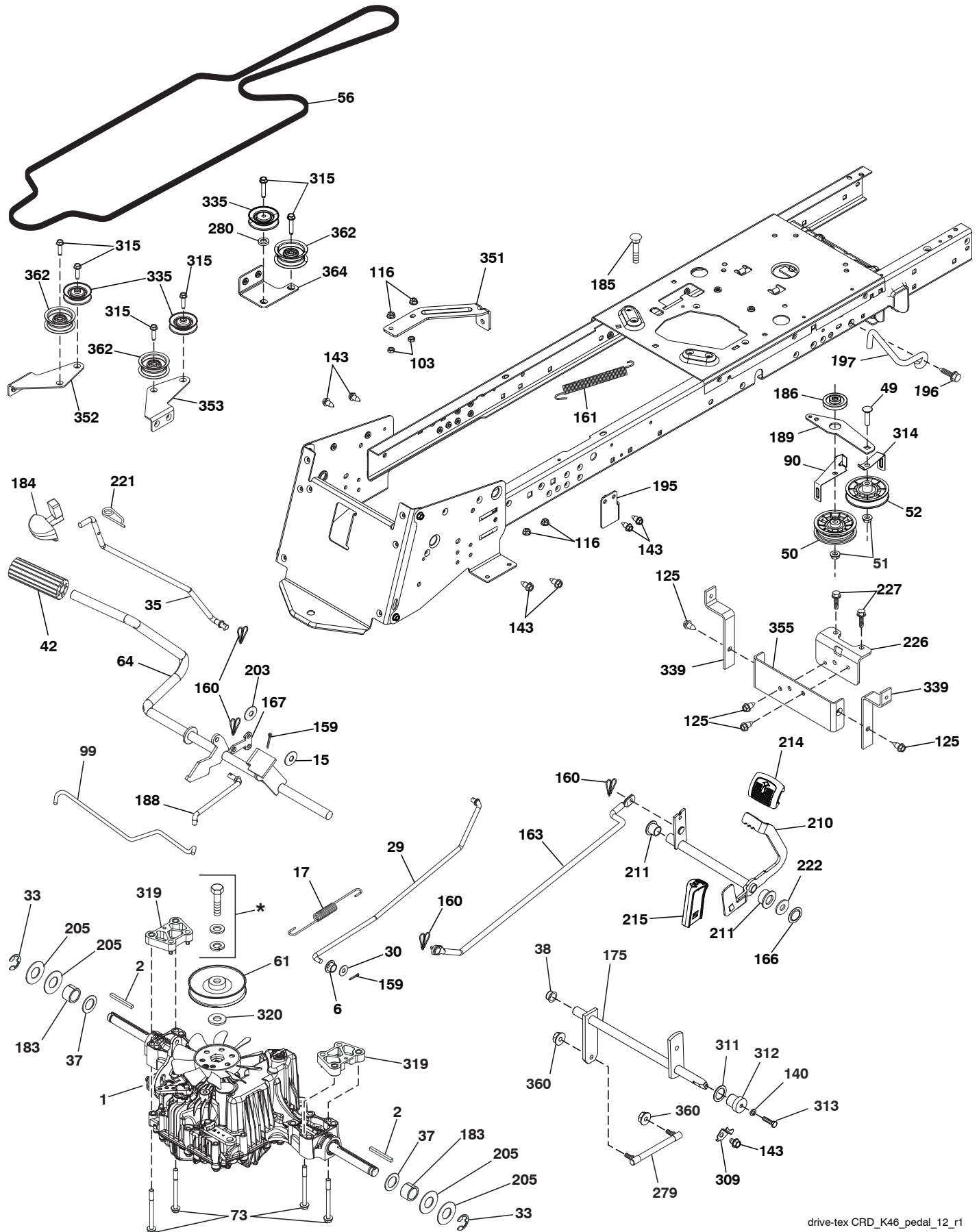

**TRACTOR - MODEL NO. CTH2138R (96051012000), PRODUCT NO. 9605101-20
DRIVE 40**

KEY NO.	PART NO.	DESCRIPTION	KEY NO.	PART NO.	DESCRIPTION
1	-----	Transaxle, TUFFTORQ K46 DF (446488) (Order parts from trans-axle manufacturer.)	189	532 43 36-11	Bellcrank Ground Drive
2	532 12 35-83	Key Square	195	580 45 69-01	Bracket Brake Rod
6	532 12 40-28	Bushing Snap	196	817 00 06-16	Screw 3/8-16 x 1
15	819 13 13-16	Washer 13/32 x 13/16 x 16 Ga.	197	585 65 86-01	Link Clutch
17	532 43 62-27	Spring, Brake	203	819 11 11-16	Washer 11/32 x 11/16 x 16 Ga.
29	532 43 58-81	Rod, Brake	205	532 12 17-48	Washer 25/32 x 1-5/8 16 Ga.
30	819 13 16-16	Washer 13/32 x 1 x 16 Ga.	210	532 40 09-80	Rocker Asm. Pedal
33	812 00 00-01	Ring E	214	532 42 12-63	Pedal Forward
35	532 40 10-31	Rod, Brake, Park	215	532 41 94-82	Pad Pedal Reverse
37	532 18 89-67	Washer .793 x 1.637 x 060	211	532 12 01-83	Bearing Nylon
38	532 16 96-13	Nylon Snap In	221	532 40 31-87	Retainer Spring
42	532 12 48-72	Cover, Foot Pedal	222	879 21 20-10	Washer Flat
49	872 11 06-14	Bolt 3/8-16 unc	226	532 40 15-64	Bracket Mount Torque
50	532 19 43-27	Idler Flat	227	817 49 05-12	Screw
51	873 90 06-00	Lock Nut 3/8-16	279	532 44 42-83	Link Shift Hydro
52	532 19 43-26	Idler V Groove	280	819 11 10-12	Washer 11/32 x 5/8 x 12 Ga.
56	532 44 18-34	V-Belt, Drive	309	532 16 55-81	Plate Fstnr.
61	532 43 77-88	Pulley Transaxle	311	532 16 98-45	Washer Nylon
64	532 19 78-65	Shaft Asm. Pedal Brake Control	312	532 16 56-14	Hub Tapered
73	874 49 05-56	Bolt Hex 5/16-18 x 3.75	313	874 78 04-16	Bolt Hex Fin 1/4-20 unc x 1.GD5
90	532 44 36-05	Keeper Belt Clutching	314	532 44 47-13	Retainer, Belt
99	532 44 39-47	Rod Bypass	315	817 58 05-20	Screw Thdrol 5/16-18 x 4.25
103	873 35 05-00	Nut 5/16-18 unc	319	532 43 67-94	Spacer Transaxle Tex CRD
116	873 90 05-00	Nut Lock Hex Flange 5/16-18	320	532 18 76-90	Washer Spacer
125	817 00 05-12	Screw 5/16-18 x 3/4	335	532 19 95-34	Idler V Pulley
140	810 04 04-00	Washer Lock Hvy. Helical 1/4	339	532 43 68-67	Strap Torue K46 CRD Tex
143	817 49 05-08	Screw Thdrol 5/16-18 x 1/2 TYTT	351	532 43 69-98	Bracket Deck Sway
159	876 02 04-12	Pin Cotter 1/8 x 3/4	352	532 43 58-19	Bracket Idler
160	532 16 94-84	Retainer Clip	353	532 43 65-77	Bracket Idler RH
161	532 10 57-09	Spring, Return, Clutch	355	532 43 56-69	Strap Torque
163	532 43 66-32	Rod Control	360	532 44 47-14	Nut Hex 5/16-24
166	532 42 91-64	Nut Push .625	362	532 43 68-12	Idler Flat
167	532 40 52-57	Latch Brake Parking	364	532 44 30-32	Bracket Idler
175	532 42 93-59	Shaft Asm. Cross Shift			
183	532 13 70-57	Spacer Axle			
184	532 44 14-07	Handle Park Brk.			
185	872 11 06-22	Bolt 3/8-16 unc x 2-3/4			
186	532 19 43-21	Spacer Retainer			
188	532 19 43-23	Link Clutch Ground Drive			

* Parts supplied by manufacturer

NOTE: All component dimensions given in U.S. inches
1 inch = 25.4 mm

**TRACTOR - MODEL NO. CTH2138R (96051012000), PRODUCT NO. 96051 01-20
ENGINE 24**

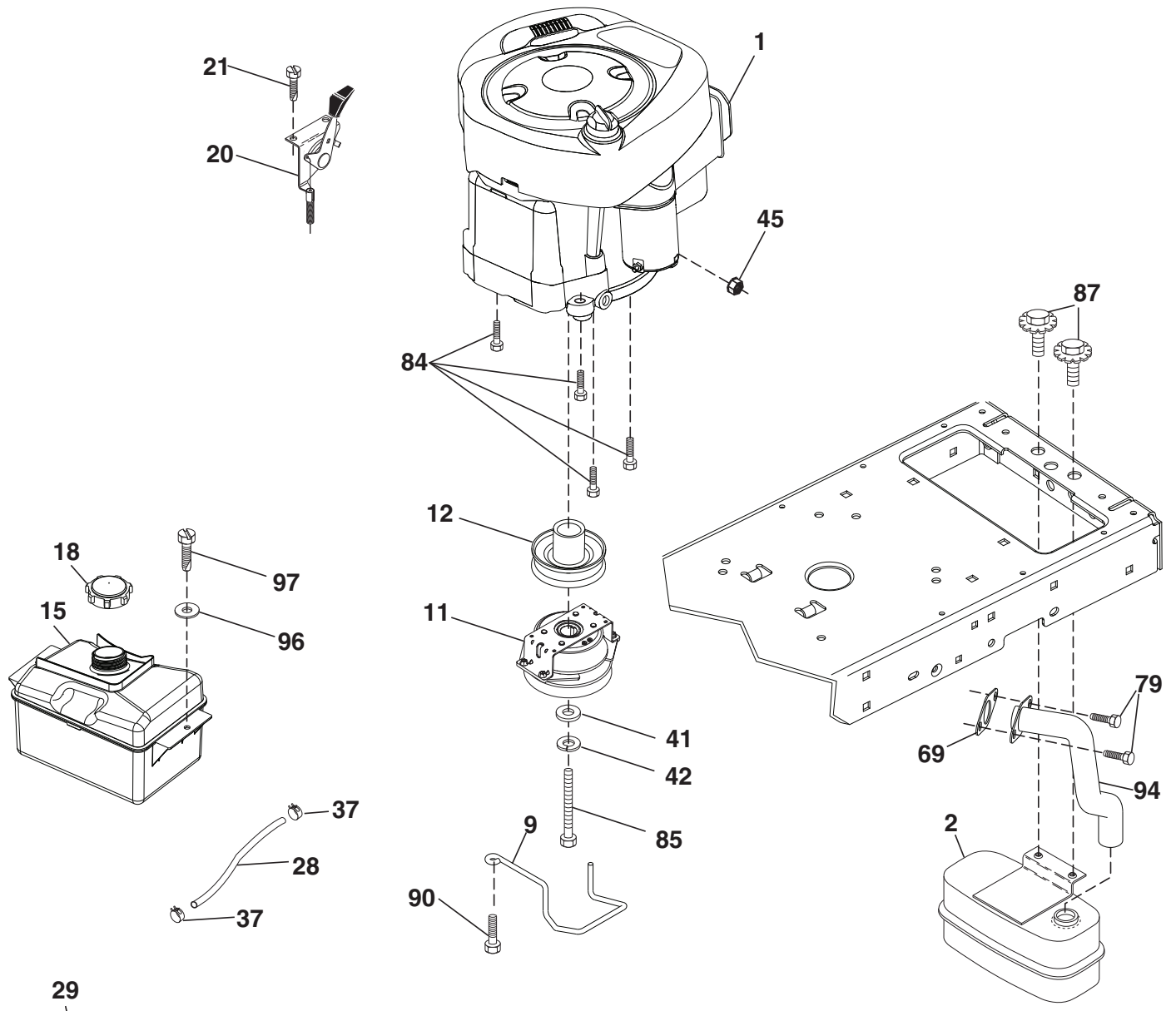

29

OPTIONAL EQUIPMENT

Spark Arrester

engine-tex_BS_97

**TRACTOR - MODEL NO. CTH2138R (96051012000), PRODUCT NO. 9605101-20
ENGINE 24**

KEY NO.	PART NO.	DESCRIPTION
1	---	Engine Briggs 33M977-0002-G5 (581187001) (Order parts from engine manufacturer.)
2	580 53 23-01	Muffler
9	584 90 80-01	Keeper Belt Engine
11	587 24 16-01	Clutch
12	532 40 50-97	Pulley Engine
15	581 28 99-01	Tank Fuel 1.5
18	532 43 02-20	Cap Fuel
20	532 18 38-97	Control Throttle
21	532 41 63-58	Screw #10 x 0.750 BOS Thread
28	532 13 70-40	Fuel Line
29	532 13 71-80	Spark Arrester Kit
37	532 12 34-87	Clamp Hose
41	532 12 61-97	Washer 1-1/2 OD. x 15/32 ID x 250
42	810 04 07-00	Wahser Lock Hvy HLCL Spr. 7/16
45	873 51 04-00	Nut Keps Hex 1/4-20 unc
69	532 16 52-91	Gasket
79	532 19 23-34	Screw Socket HD. 5/16-18 x .75
84	817 06 06-20	Screw 3/8-16 x 1 1/4
85	532 17 99-53	Bolt Hex 7/16-20 x 3.75
87	532 17 18-77	Bolt 5/16-18 x 3/4
90	817 00 06-16	Screw 3/8-16 x 1
94	581 88 09-01	Tube Exhaust
96	819 09 14-16	Washer 9/32 x 7/8 x 16 Ga.
97	817 67 04-12	Screw 1/4-20 x 3/4

NOTE: All component dimensions given in U.S. inches
1 inch = 25.4 mm

Engine Power Rating Information

The gross power rating for individual gas engine models is labeled in accordance with SAE (Society of Automotive Engineers) code J1940 (Small Engine Power & Torque Rating Procedure), and rating performance has been obtained and corrected in accordance with SAE J1995 (Revision 2002-05). Torque values are derived at 3060 RPM; horsepower values are derived at 3600 RPM. Actual gross engine power will be lower and is affected by, among other things, ambient operating conditions and engine-to-engine variability. Given both the wide array of products on which engines are placed and the variety of environmental issues applicable to operating the equipment, the gas engine will not develop the rated gross power when used in a given piece of power equipment (actual “on-site” or net power). This difference is due to a variety of factors including, but not limited to, accessories (air cleaner, exhaust, charging, cooling, carburetor, fuel pump, etc.), application limitations, ambient operating conditions (temperature, humidity, altitude), and engine-to-engine variability. Due to manufacturing and capacity limitations, Briggs & Stratton may substitute an engine of higher rated power for this Series engine.

TRACTOR - MODEL NO. CTH2138R (96051012000), PRODUCT NO. 96051 01-20
STEERING ASSEMBLY 41

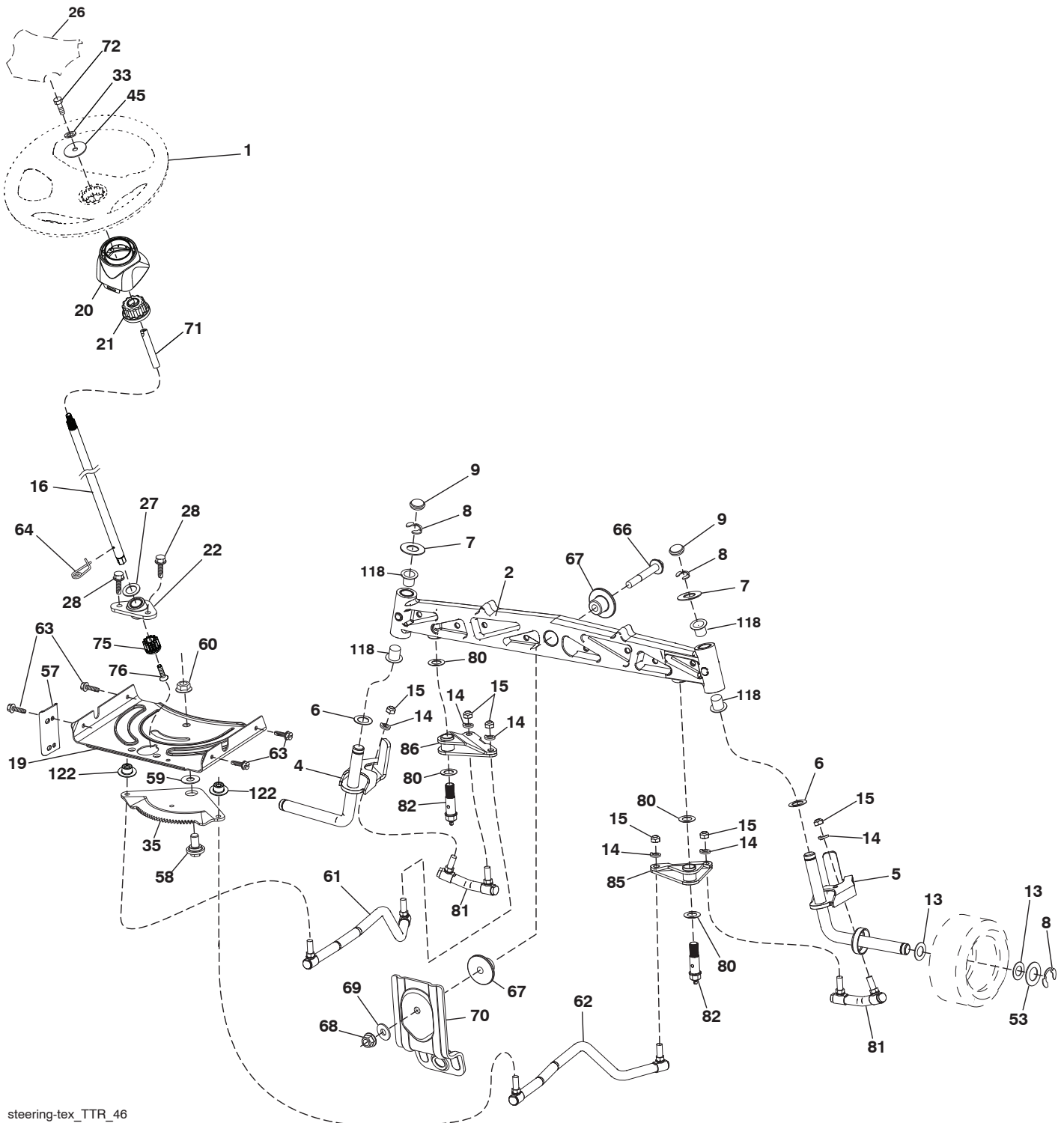

steering-tex_TTR_46

TRACTOR - MODEL NO. CTH2138R (96051012000), PRODUCT NO. 9605101-20
STEERING ASSEMBLY 41

KEY NO.	PART NO.	DESCRIPTION
1	532 43 97-40	Wheel, Steering Husq SR
2	532 43 68-70	Axle Asm., Front
4	532 43 68-73	Spindle Asm., LH
5	532 43 68-74	Spindle Asm., RH
6	532 12 49-31	Bearing, Race Thrust Hardened
7	532 12 17-48	Washer 25/32 x 1-5/8 x 16 Ga.
8	812 00 00-29	Ring, Clip #T5304-75
9	532 12 12-32	Cap, Spindle
13	532 12 17-49	Washer 25/32 x 1-1/4 x 16 Ga.
14	810 04 06-00	Washer, Lock Hvy. Hlcl. Spr. 3/8
15	873 54 06-00	Nut, Crown Lock 3/8-24 unf
16	585 86 92-02	Shaft Steering
19	532 19 47-29	Plate Steering
20	532 44 14-25	Boot, Steering
21	532 43 77-47	Adapter, Wheel Steering
22	585 02 99-01	Bearing Asm.
26	532 43 97-43	Insert, Wheel Steering Husq SR
27	819 21 16-16	Washer 21/32 x 1 x 16 Ga.
28	817 00 06-12	Screw 3/8-16 x 3/4
33	810 04 05-00	Washer Lock 5/16
35	532 44 07-70	Gear, Sector
45	819 11 38-12	Washer 11/32 x 3/8 x 12 Ga.
53	532 18 89-67	Washer Hardened .793 x 1.637 x .060
57	532 40 74-65	Bracket Upstop
58	532 19 47-47	Bolt Shoulder Sector Pivot CFM
59	532 19 47-48	Washer Thrust Sector Steering
60	873 97 10-00	Nut Flange Lock 5/8-11
61	532 43 68-84	Draglink, LH
62	532 43 68-85	Draglink, RH
63	817 00 05-12	Screw 5/16-18 x 3/4
64	532 19 98-49	Retainer Clip Spring Steering
66	871 02 07-48	Bolt Hex Fghd. 7/16-14 x 3 Serr.
67	532 19 47-37	Bushing PM Front Axle
68	873 90 07-00	Nut Lock Flange 7/16-14 Gr. 5
69	532 19 91-62	Washer 1.5 x .505 x .118
70	532 19 61-97	Bracket Deck Susp. Front
71	532 19 07-52	Shaft Extension Steering
72	532 42 89-82	Bolt Fin Hx 5/16-18 x 4 w/Patch
75	580 68 37-01	Pinion
76	580 68 36-01	Screw
80	532 00 13-70	Washer 5/8 x 1.10 x 1/32
81	532 43 68-87	Link Cross RH
82	532 43 68-77	Subasm. Pivot Bolt
85	532 44 18-73	Subasm. Pivot RH
86	532 44 18-72	Subasm. Pivot
118	532 40 60-13	Bushing
122	532 44 49-62	Cap Gear

NOTE: All component dimensions given in U.S. inches
1 inch = 25.4 mm

TRACTOR - MODEL NO. CTH2138R (96051012000), PRODUCT NO. 96051 01-20
MOWER DECK 44

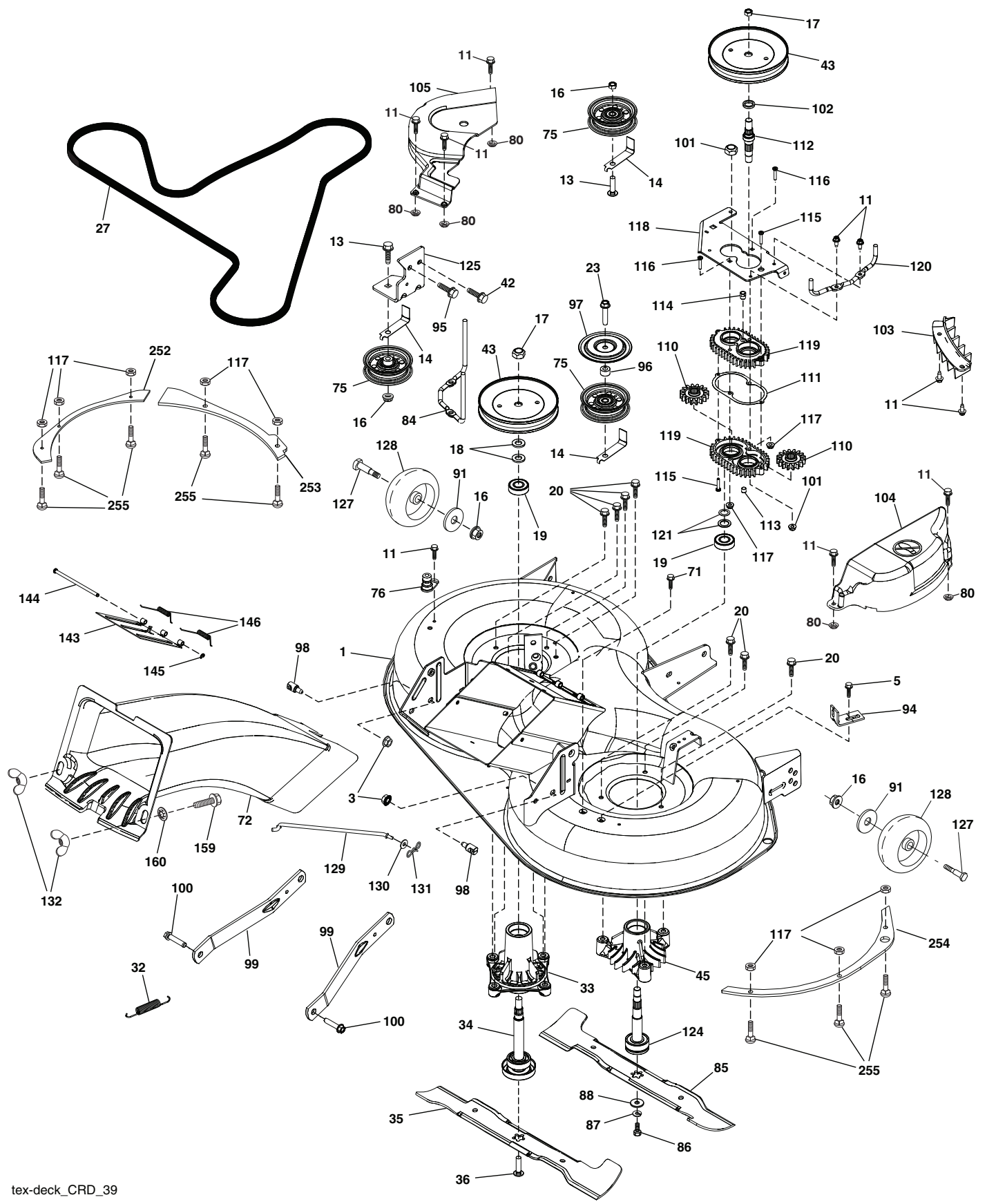

tex-deck_CRD_39

TRACTOR - MODEL NO. CTH2138R (96051012000), PRODUCT NO. 9605101-20
MOWER DECK 44

KEY NO.	PART NO.	DESCRIPTION	KEY NO.	PART NO.	DESCRIPTION
1	580 46 53-02	Deck Weldment	104	532 43 89-68	Mandrel Cover RH
3	873 90 05-00	Nut Lock Hex Flange 5/16-18	105	532 43 87-44	Mandrel Cover LH
5	817 00 05-10	Bolt 5/16-18	110	587 93 48-01	Gear Output
11	532 13 77-29	Screw Thd Roll 1/4 - 20 x 5/8	111	532 43 69-79	Gasket Gearcase
13	872 11 06-12	Bolt Carr Sh 3/8 - 16 X 1 - 1/2 Gr. 5	112	532 44 38-52	Shaft Gearcase
14	532 15 60-85	Keeper Belt Idler	113	532 43 85-33	Plug Oil
16	873 90 06-00	Nut Lock FIG 3/8 - 16 unc	114	532 43 85-34	Valve Relief
17	532 40 02-34	Nut Flange Lock Top	115	818 03 10-16	Screw Torx #10-24 x 1
18	532 18 76-90	Washer Spacer Mandrel	116	872 11 04-14	Bolt 1/4-20 x 1.75 Gr. 5
19	532 11 04-85	Bearing Ball Mandrel	117	873 90 04-00	Nut Hex Flange 1/4-20 unc
20	532 17 39-84	Screw Thread Roll	118	532 43 69-89	Arm Clutching
23	817 49 06-28	Screw Thdrol 3/8 - 16 x 1-3/4	119	532 43 81-66	Gearcase Subasm
27	532 44 58-34	V-Belt Drive	120	532 43 69-91	Keeper Belt RH
32	532 44 62-05	Spring Drive Deck	121	532 43 69-85	Washer
33	532 18 72-81	Housing Mandrel 4pt Service	124	532 43 69-86	Non Greasable Mandrel Shaft
34	532 19 28-72	Shaft Asm Mndrl N/Greaseable38	125	532 43 69-94	Bracket Idler Chasses
35	532 42 79-84	Blade Mower LH	127	532 19 34-06	Bolt Shoulder 3/8-16 x 3-5/8 Gr. 5
36	532 19 30-03	Bolt/Washer Asm 7/16 - 20 unf	128	532 17 48-73	Wheel Guage
42	817 00 05-12	Screw 5/16-18 x 3/4	129	532 40 48-51	Rod Anti-Sway
43	532 19 97-89	Pulley Mandrel	130	819 13 13-12	Washer 13/32 x 13/16 x 12 Ga.
45	532 13 71-52	Housing Mandrel	131	532 19 42-08	Pin Cotter 5/16 Bow Tie Lock
71	817 67 06-08	Screw Thdrol 3/8-16 x 1/2	132	532 17 88-99	Knob Handle
72	532 44 68-10	Chute Upper	143	532 43 55-38	Door Mulch
75	532 13 14-94	Pulley Idler Flat	144	532 43 58-61	Pin Hinge
76	532 41 55-98	Washout Port	145	532 43 79-88	E-Ring 5/16"
80	532 42 30-62	Pal Nut	146	532 44 58-96	Spring
84	532 40 01-40	Keeper Belt LH Mandrel	159	872 14 06-14	Bolt 3/8-16 x 1-3/4
85	532 42 79-85	Blade Mower RH	160	532 16 89-37	Nut Push
86	532 18 17-13	Bolt 3/8-24 x 1.50 Gr. 8	252	581 55 44-02	Plate Left
87	810 03 06-00	Washer Lock Hvy 3/8	253	581 55 45-02	Plate LHS
88	532 14 02-96	Washer Hard Blade Mower Vented	254	581 55 47-02	Plate RHS
91	819 13 20-12	Washer 13/32 x 1-1/4 x 12 Ga.	255	539 10 98-00	Carriage Bolt 1/4-20 unc
94	532 19 72-50	Bracket Clutch Cable	--	532 19 28-70	Mandrel Assembly (Includes Housing (key#33), Shaft Assembly (key#34), And Bearing (key#19) Only - Pulley/Nut/Washer And Blade Bolt/Washers Not Included)
95	817 00 06-12	Screw 3/8-16 x 3/4			Replacement Mower Complete
96	532 40 02-71	Spacer			
97	532 18 20-61	Shield Idler Mower			
98	532 19 51-61	Stud Fastener			
99	532 19 51-86	Arm Suspension Mower Rear	--	585 38 57-01	
100	532 19 65-39	Bolt Shoulder			
101	873 68 09-00	Nut Crownlock 9/16-18 unc			
102	532 40 25-11	Spacer Bearing Swing Plate			
103	532 43 69-92	Guard Front Vent			

NOTE: All component dimensions given in U.S. inches
1 inch = 25.4 mm

TRACTOR - MODEL NO. CTH2138R (96051012000), PRODUCT NO. 96051 01-20
MOWER LIFT 45

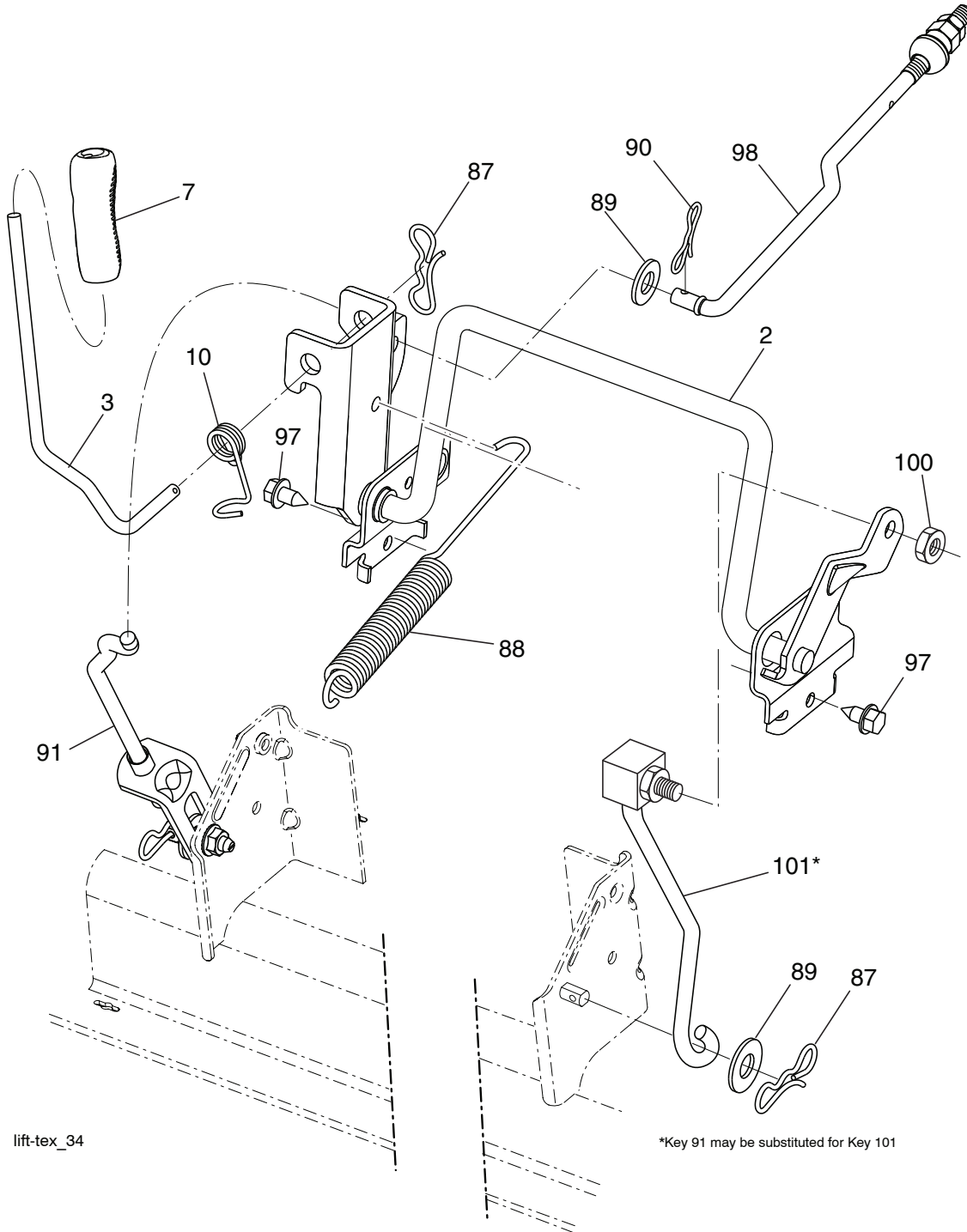

lift-tex_34

*Key 91 may be substituted for Key 101

KEY NO.	PART NO.	DESCRIPTION
2	532 43 69-96	Deck Lift Weldment
3	532 19 52-31	Lever Asm., Lift RH
7	580 96 23-01	Grip, Lever
10	532 19 63-14	Spring Torsion
87	532 19 42-09	Pin Cotter 7/16 Bow Tie Lock
88	532 43 69-95	Spring Lift Assist
89	819 19 19-12	Washer Clear Zinc
90	532 19 42-08	Pin Cotter 5/16 Bow Tie Lock

KEY NO.	PART NO.	DESCRIPTION
91	532 19 51-81	Link Lift Susp. Mower Rear
97	817 49 06-08	Screw 3/8-16 x 1/2
98	532 19 52-70	Link Lift Susp. Front Mower
100	873 93 06-00	Nut Centerlock 3/8-16
101	532 40-70-03	Link Asm. Lift FXD

NOTE: All component dimensions given in U.S. inches
 1 inch = 25.4 mm

TRACTOR - MODEL NO. CTH2138R (96051012000), PRODUCT NO. 9605101-20
SEAT ASSEMBLY 42

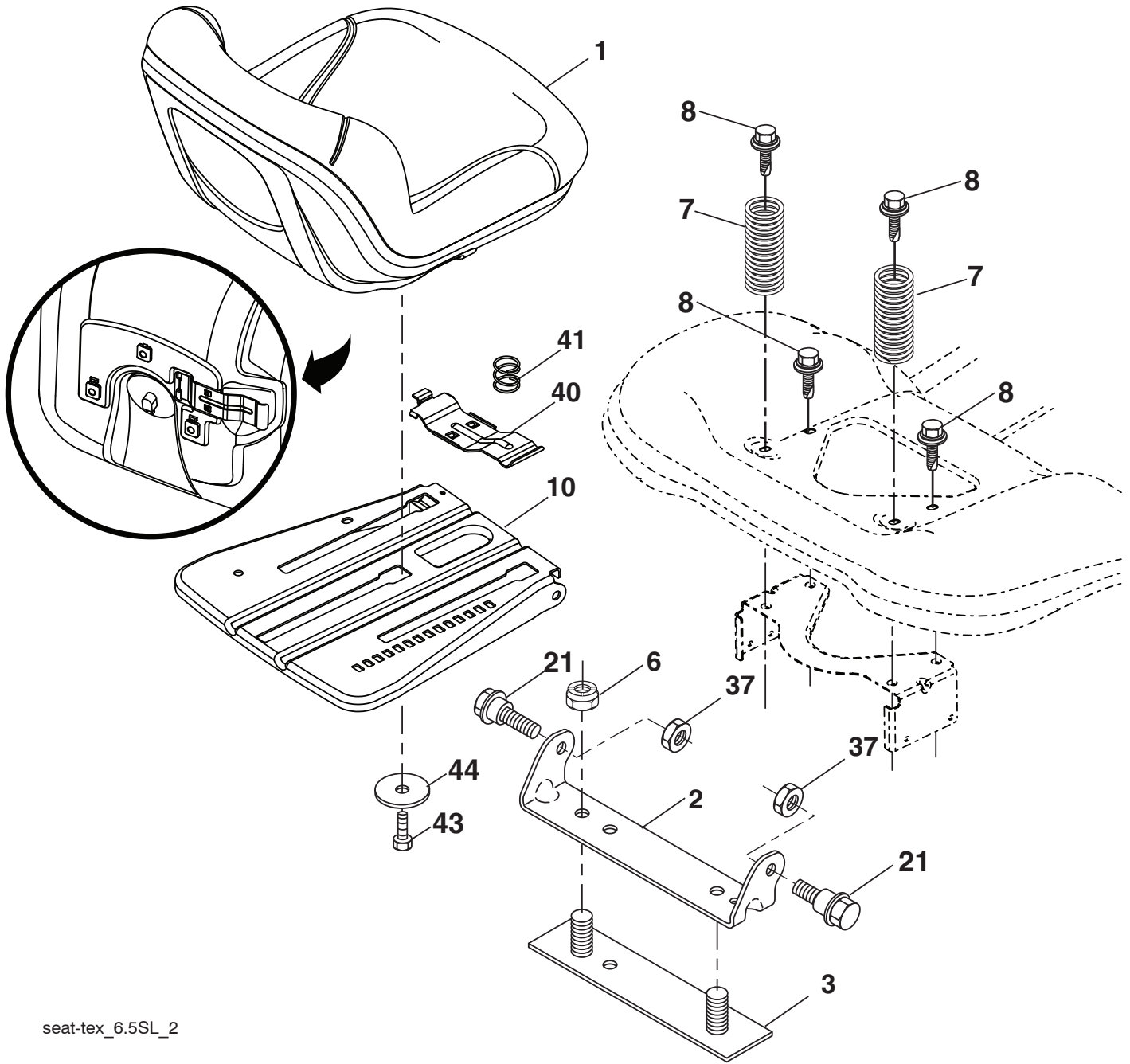

seat-tex_6.5SL_2

KEY NO.	PART NO.	DESCRIPTION
1	532 43 98-22	Seat
2	532 18 01-66	Bracket Pivot Fender
3	532 14 06-75	Strap, Asm. Fender
6	873 80 06-00	Nut, Lock w/Ins. 3/8-16 unc
7	532 12 41-81	Spring, Seat Cprsn.
8	532 17 18-77	Bolt 5/16-18 unc x 3/4 w/Sems.
10	532 19 69-77	Pan, Seat
21	532 17 18-52	Bolt, Shoulder 5/16-18

KEY NO.	PART NO.	DESCRIPTION
37	873 80 05-00	Nut, Lock 5/16-18 unc
40	532 19 76-61	Handle
41	532 19 82-00	Spring
43	874 76 06-12	Bolt 3/8-16 unc x 3/4
44	819 13 38-12	Washer 13/32 x 2-3/8 x 12 Ga.

NOTE: All component dimensions given in U.S. inches
 1 inch = 25.4 mm

TRACTOR - MODEL NO. CTH2138R (96051012000), PRODUCT NO. 96051 01-20
BAGGER **46**

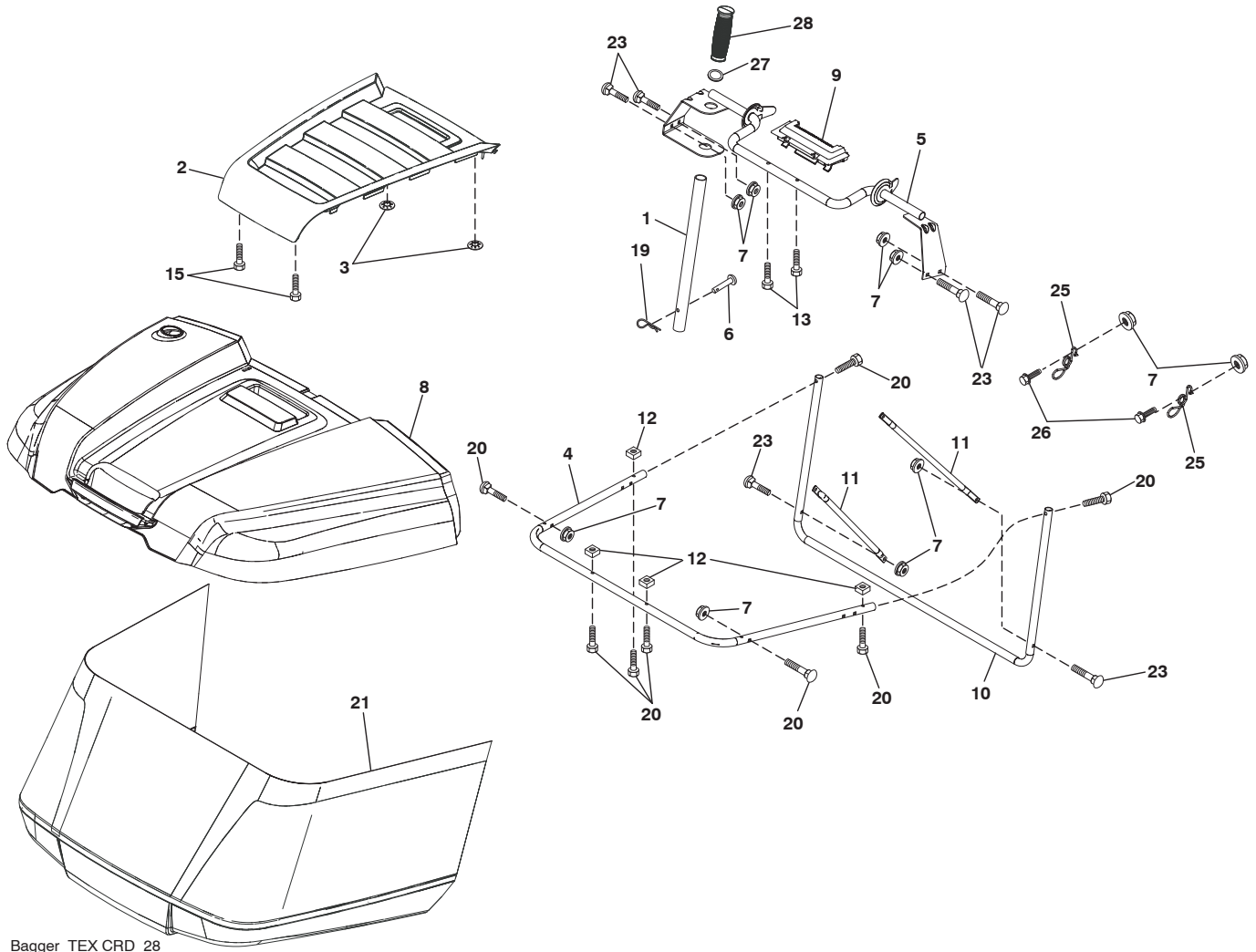

Bagger_TEX CRD_28

TRACTOR - MODEL NO. CTH2138R (96051012000), PRODUCT NO. 9605101-20
BAGGER 46

KEY NO.	PART NO.	DESCRIPTION
1	532 42 86-10	Tube Handle Bagger
2	532 44 13-58	Applique Top
3	532 41 38-08	Nut Push .156
4	532 43 96-12	Frame Asm Bagger Top
5	532 41 76-32	Frame Asm Top Bagger
6	532 12 68-75	Rivet Drilled
7	873 90 04-00	Nut Hex Flange 1/4-20 unc
8	532 44 12-61	Cover Bagger
9	532 41 76-29	Insert Handle Bagger
10	532 43 67-70	Frame Front
11	532 43 67-71	Tubing Brace Bagger
12	532 42 17-93	Nut Square 1/4
13	532 42 17-80	Screw 1/4 x 1.150
15	532 42 18-01	Screw #8 Flat Head
19	532 19 42-08	Cotter Pin 5/16 Bow Tie
20	585 36 88-01	Screw Hex Cap 1/4-20 x 1.375
21	532 44 83-06	Bag Asm
23	872 04 04-10	Bolt Carr. 1/4-20
25	532 42 16-14	Spring Latch
26	817 49 04-12	Screw 1/4-20 x 3/4
27	532 42 12-62	Grommet Rubber
28	532 16 57-87	Grip Handle Black

NOTE: All component dimensions given in U.S. inches
1 inch = 25.4 mm

