

ILLUSTRATED PARTS LIST

MFG. ID NO. 96041033100

CUSTOMER CATALOG NO. YTH 184T

PRODUCT NO. 960 41 03-31

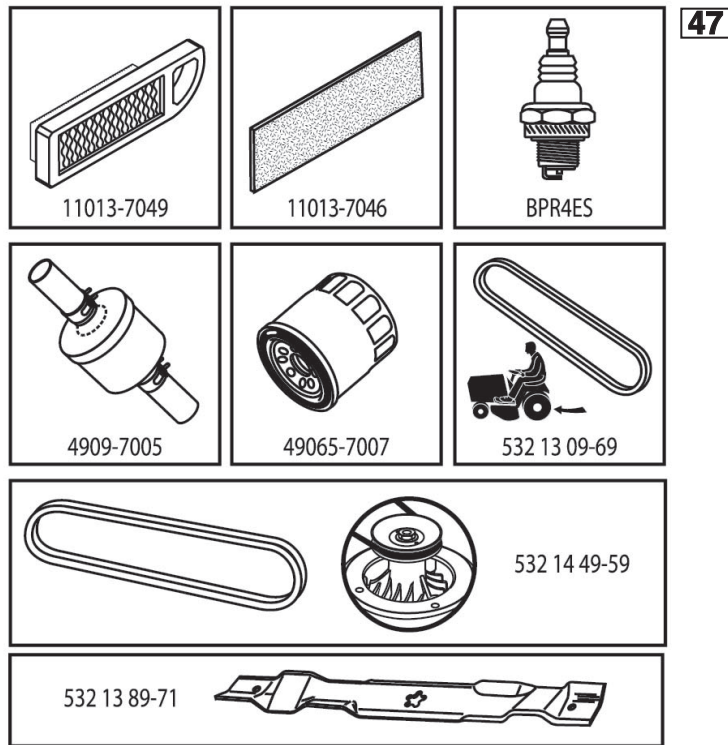

581517301

**TRACTOR - MODEL NO. YTH 184T (96041033100), PRODUCT NO. 960 41 03-31
DECALS 27**

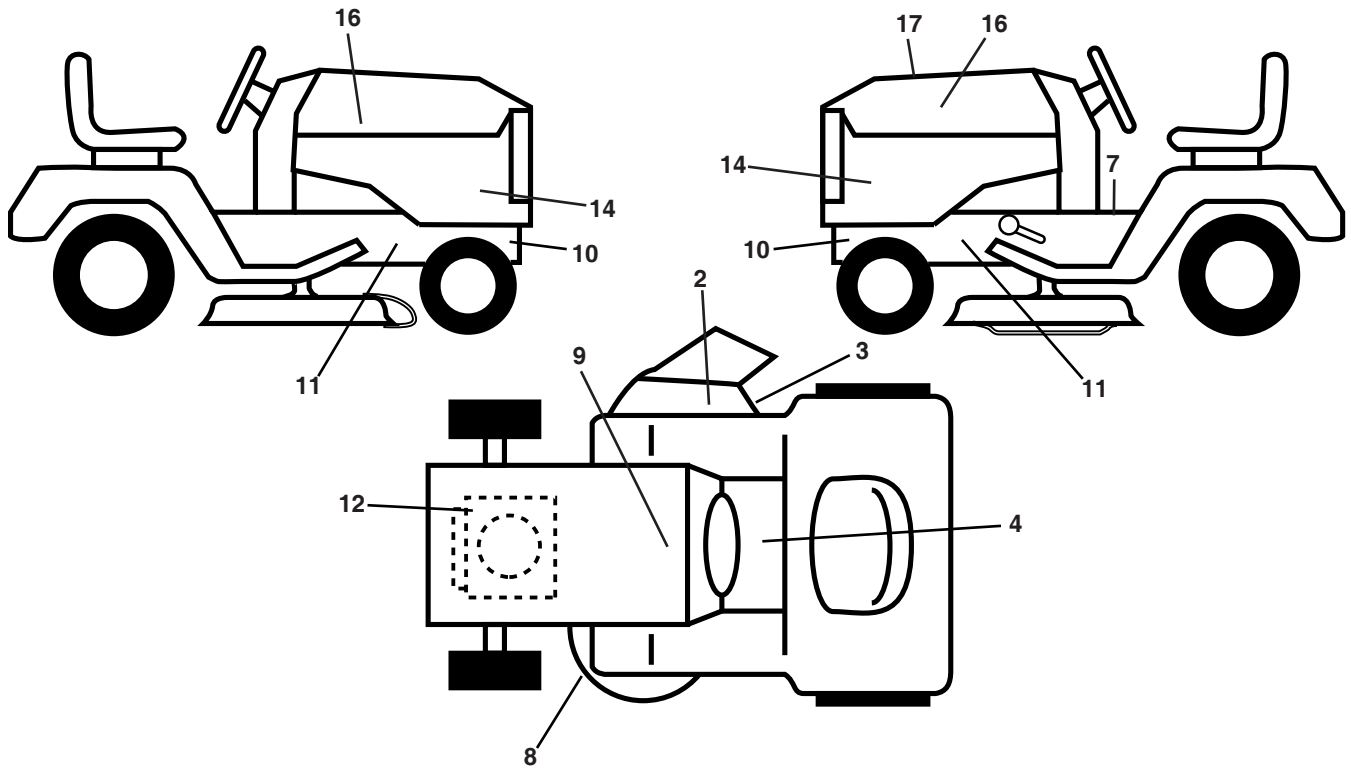

KEY NO.	PART NO.	DESCRIPTION
2	584 90 46-01	Decal, Deflect. Warning
3	581 57 92-01	Decal, Warning Symbol
4	581 57 80-01	Decal, Brake Parking
7	581 57 81-01	Decal, Brake/Clutch Symbol
8	581 58 00-01	Decal, Mower Sch.
9	532 14 50-05	Decal, Battery Dnge/Poi
10	581 57 96-01	Decal, Hot Muffler
11	581 57 98-01	Decal, Warning
12	581 57 97-01	Decal, Warning Eng. Symbol
14	532 44 74-37	Decal, Panel Side

KEY NO.	PART NO.	DESCRIPTION
16	581 62 73-01	Emblem
17	581 51 73-01	Decal, Replacement
--	581 72 48-01	Decal, Bypass
--	581 72 46-01	Decal, Load Limit
--	532 43 98-82	Pad, Footrest, LH
--	532 43 98-81	Pad, Footrest, RH
--	115 61 05-20	Manual Oper. Euro
--	115 61 05-10	Manual Oper. Scan
--	115 61 05-50	Manual Oper. Ebloc
--	115 61 05-40	Manual Oper. Baltic

WHEELS AND TIRES

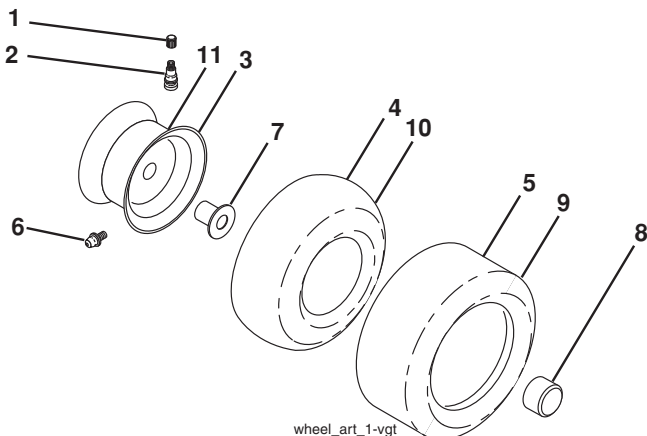

KEY NO.	PART NO.	DESCRIPTION
1	532 05 91-92	Cap, Valve, Tire
2	532 06 51-39	Stem, Valve
3	532 13 83-36	Rim Assembly, Front
4	532 05 99-04	Tube, Front (Service Item Only)
5	532 10 62-22	Tire, Front
6	532 12 49-57	Fitting, Grease (Front Wheel Only)
7	532 12 49-59	Bearing, Flange (Front Wheel Only)
8	532 17 50-39	Cap, Axle (Front Wheel Only)
9	532 12 20-82	Tire, Rear
10	532 12 49-26	Tube, Rear (Service Item Only)
11	532 13 83-37	Rim Assembly, Rear
--	532 14 43-34	Sealant, Tire (10 oz. Tube)

NOTE: All component dimensions given in U.S. inches
1 inch = 25.4 mm

TRACTOR - MODEL NO. YTH 184T (96041033100), PRODUCT NO. 960 41 03-31

SCHEMATIC 38

SCH12

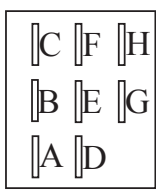
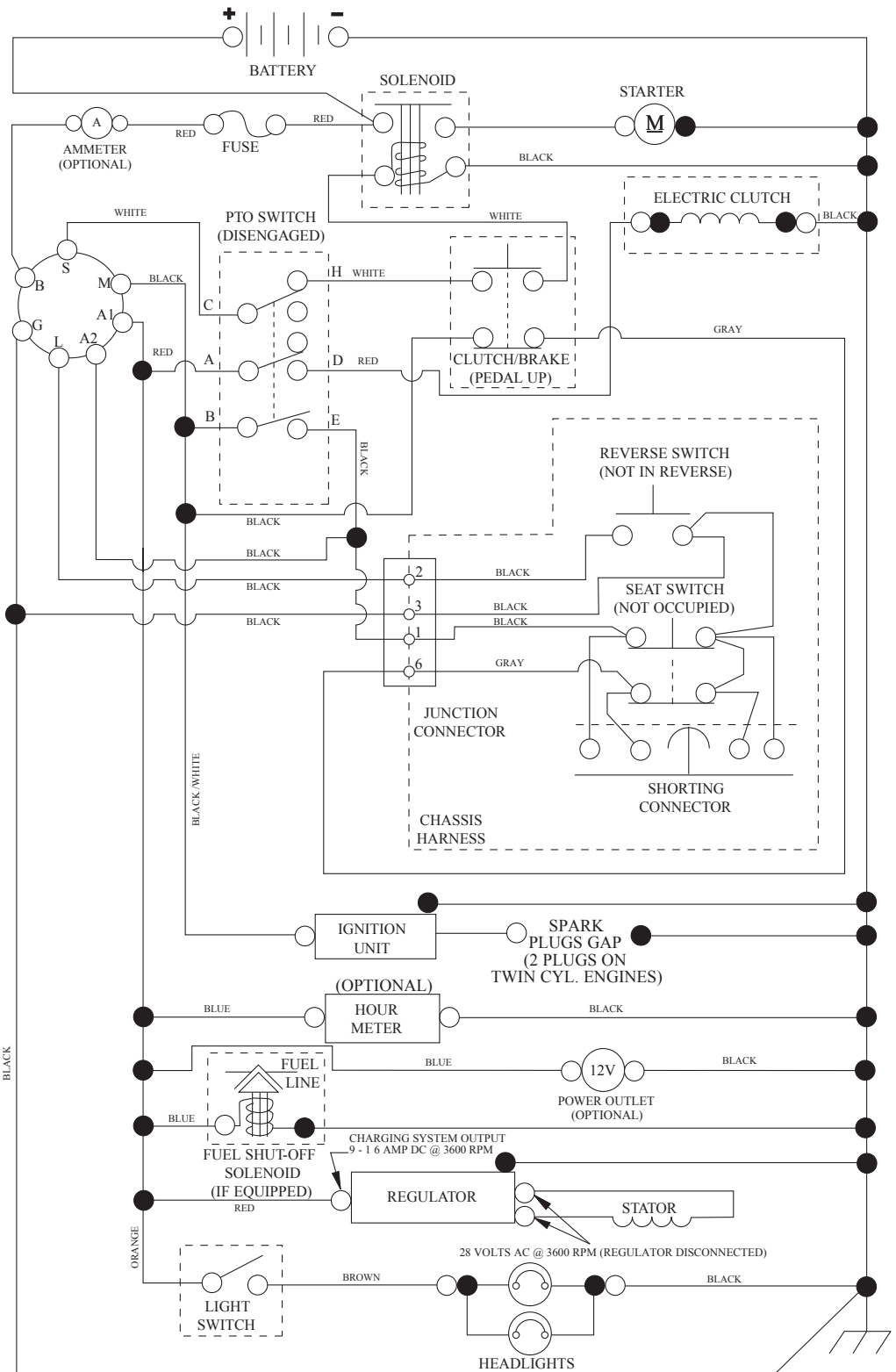

PTO SWITCH (MATING SIDE)

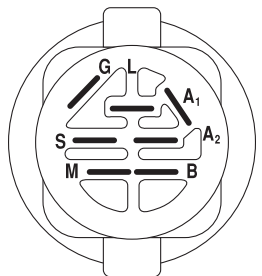

IGNITION SWITCH

POSITION	CIRCUIT	"MAKE"
OFF	M+G+A1	
RUN/OVERRIDE	B+A1	
RUN	B+A1	L+A2
START	B+S+A1	

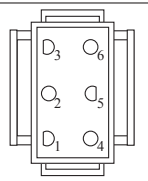

CHASSIS HARNESS CONNECTOR (MATING SIDE)

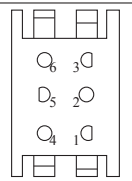

DASH HARNESS CONNECTOR

WIRING INSULATED CLIPS
NOTE: IF WIRING INSULATED CLIPS WERE REMOVED FOR SERVICING OF UNIT, THEY SHOULD BE RE-INSTALLED TO PROPERLY SECURE YOUR WIRING.



TRACTOR - MODEL NO. YTH 184T (96041033100), PRODUCT NO. 960 41 03-31
ELECTRICAL 32

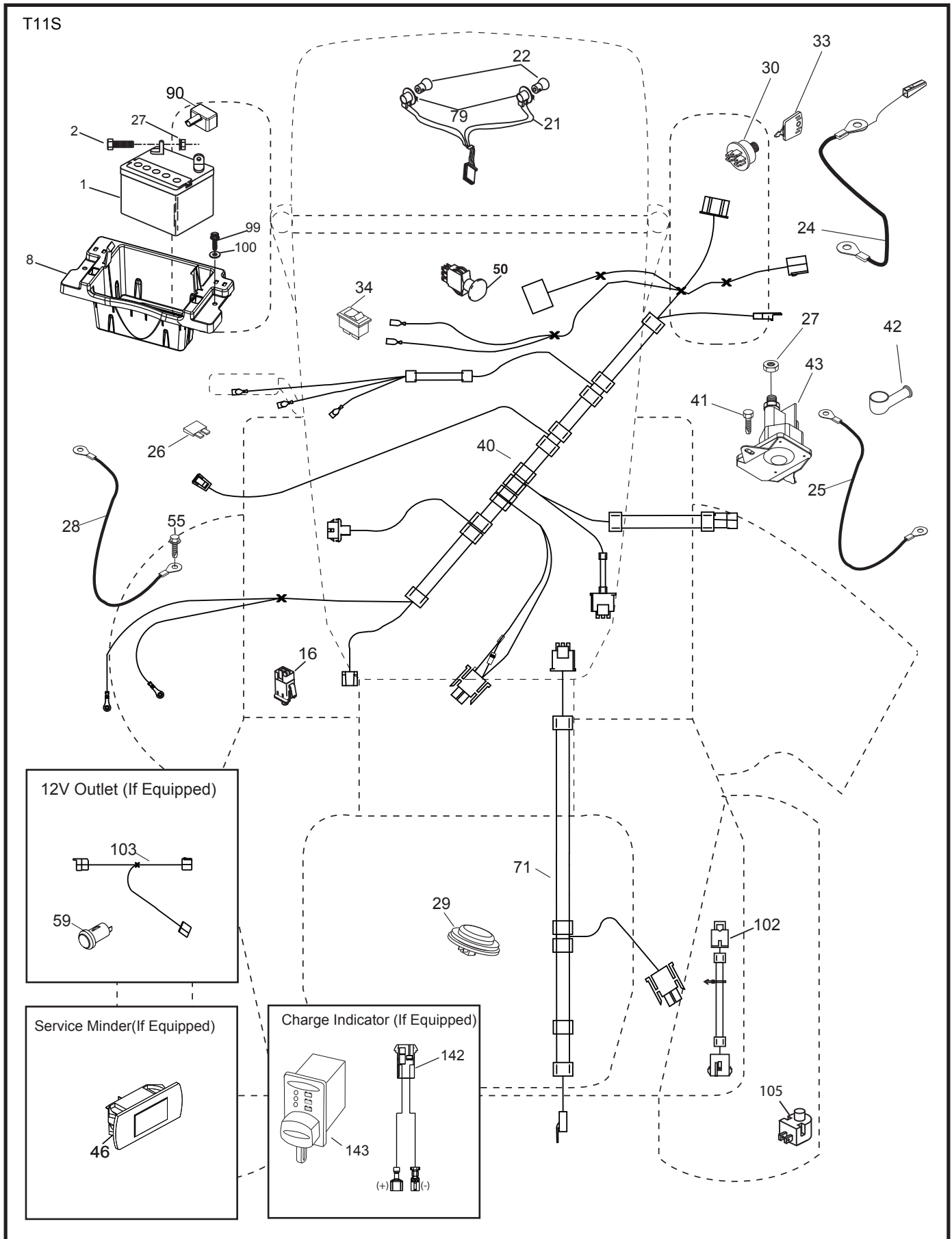

**TRACTOR - MODEL NO. YTH 184T (96041033100), PRODUCT NO. 960 41 03-31
ELECTRICAL 32**

KEY NO.	PART NO.	DESCRIPTION
1	532 16 34-65	Battery
2	874 76 04-12	Bolt Hex Hd 1/4-20 unc x 3/4
8	587 20 51-01	Battery Box
16	532 17 61-38	Switch Interlock
21	532 40 02-52	Harness Socket Light
22	532 00 41-52	Bulb, Light #1156
24	532 40 02-53	Cable Battery
25	532 41 28-95	Cable Starter
26	532 17 51-58	Fuse
27	873 51 04-00	Nut Keps Hex 1/4-20 unc
28	532 14 54-91	Cable Ground 21" Blk 6 Ga.
29	532 40 15-45	Switch Seat
30	532 19 33-50	Switch Ign
33	532 41 19-35	Key/Chain
34	532 11 07-12	Switch Light/Reset
40	532 19 42-76	Harness Ign
41	817 72 04-08	Screw Thd Cut 1/4-20 x 1/2
42	532 13 15-63	Cover Terminal Red
43	532 19 25-07	Solenoid
46	532 40 17-63	Gauge Hourmeter
50	532 17 46-51	Switch PTO
55	817 06 05-12	Screw Thdrol 5/16-18 x 3/4
71	581 02 27-01	Harness Ign. Dash
79	532 17 52-42	Socket Asm. Bulb
90	532 43 53-95	Cover Terminal Battery
99	817 67 04-12	Screw Hexwsh Thdrol 1/4-20 x 3/4
100	819 09 14-16	Washer 9/32 x 7/8 x 16 Ga.
102	532 40 75-68	Switch Reverse
105	532 40 44-54	Harness Pigtail
142	583 85 78-01	Charge Port Pigtail
143	532 44 80-59	Charge Port

NOTE: All component dimensions given in U.S. inches
1 inch = 25.4 mm

TRACTOR - MODEL NO. YTH 184T (96041033100), PRODUCT NO. 960 41 03-31
CHASSIS AND ENCLOSURES **39**

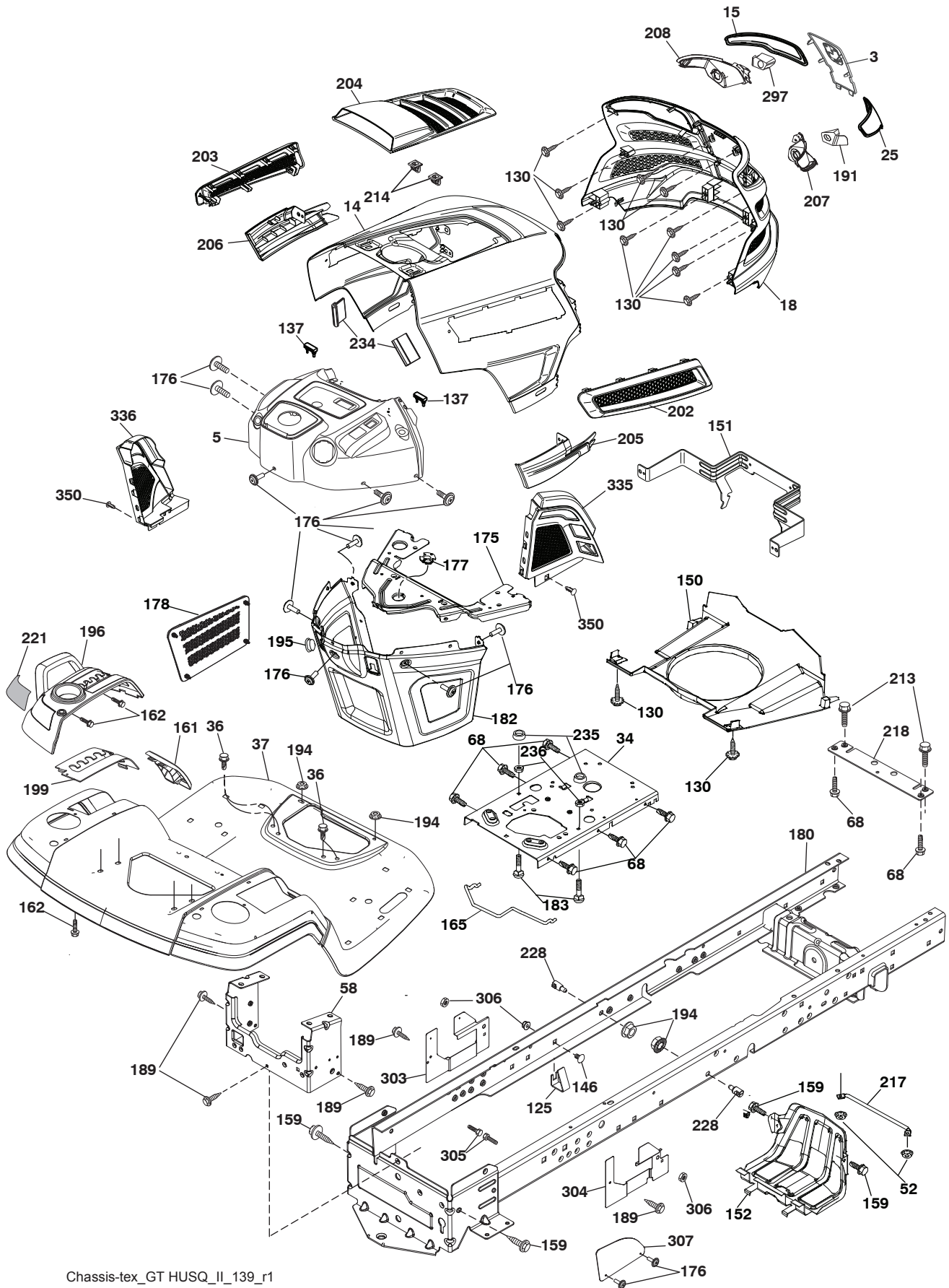

Chassis-tex_GT HUSQ_II_139_r1

**TRACTOR - MODEL NO. YTH 184T (96041033100), PRODUCT NO. 960 41 03-31
CHASSIS AND ENCLOSURES 39**

KEY NO.	PART NO.	DESCRIPTION	KEY NO.	PART NO.	DESCRIPTION
3	532 43 97-52	Logo	195	532 40 41-37	Plug 12v Adapter
5	532 43 74-84	Dash	196	532 43 97-16	Console Asm. Deck Lift
14	532 44 11-77	Hood	199	532 19 82-59	Plate Deck Lift
15	532 43 97-33	Lens LH	202	532 43 97-28	Vent Side Hood RH
18	532 44 06-53	Grille	203	532 43 97-27	Vent Side Hood LH
25	532 44 33-85	Lens RH	204	532 43 57-14	Vent Asm Hood Top
34	580 91 08-01	Plate Engine	205	532 43 97-30	Skirt Hood Side RH
36	817 06 05-12	Screw 5/16-18 x 3/4	206	532 43 97-29	Skirt Hood Side LH
37	532 44 12-08	Fender	207	532 43 97-34	Bezel RH
52	873 68 05-00	Nut Crown Lock 5/16-18	208	532 43 97-35	Bezel LH
58	532 41 22-81	Drawbar Upper	213	874 76 05-12	Bolt Hex Hd 5/16-18 unc x 3/4
68	817 49 05-08	Screw 5/16-18 x 1/2	214	532 19 91-45	Clip Retainer
125	581 68 48-01	Clip Fuel Line	217	532 40 91-67	Rod Pivot
130	532 41 63-58	Screw #10 x 0.750 BOS Thread	218	532 19 63-95	Hood Stop
137	532 40 75-90	Bumper Hood/Dash	221	532 19 89-09	Reflector LH
146	581 85 79-01	Bolt	228	532 19 51-61	Stud Fastner
150	532 43 97-31	Duct Air	234	532 40 47-42	Bumper Hood
151	532 43 66-70	Bracket Pivot	235	532 40 61-29	Spacer Fender
152	532 43 98-70	Shield Browning	236	873 93 05-00	Nut Center Lock 5/16-18 unc
159	817 00 06-12	Screw Hexwsh Thdr 3/8-16 x 3/4	297	532 43 74-56	Insert Reflective LH
161	532 43 99-29	Console Fuel Window	303	532 42 09-59	Shield Chassis LH
162	532 14 24-32	Screw Hex Wsh Hi-Lo 1/4 x 1/2	304	532 42 15-09	Shield Chassis RH
165	532 19 68-26	Bracket Support Tank	305	872 11 06-06	Bolt 3/8-16 x 3/4
175	532 19 63-04	Crossmember	306	873 90 06-00	Nut 3/8-16
176	532 40 07-76	Screw 10-24 x 5/8 Rnd Qdrx	307	532 42 45-70	Shield Upper
177	532 19 52-28	Bushing Steering	335	532 44 82-04	Cover Dash RH
178	532 19 97-82	Cargo Asm. Net	336	532 44 53-09	Cover Dash LH
180	532 41 50-64	Chassis	350	532 44 51-43	Clip X-mas Tree
182	532 40 68-59	Dash Lower	--	532 40 09-44	Bumper Kit
183	874 52 05-20	Bolt Hex 5/16-18 x 1-1/4			
189	817 00 05-12	Screw 5/16-18 x 3/4			
191	532 43 74-55	Insert Reflective RH			
194	873 90 05-00	Nut Lock Hex Flange 5/16-18			

NOTE: All component dimensions given in U.S. inches
1 inch = 25.4 mm

TRACTOR - MODEL NO. YTH 184T (96041033100), PRODUCT NO. 960 41 03-31
DRIVE **40**

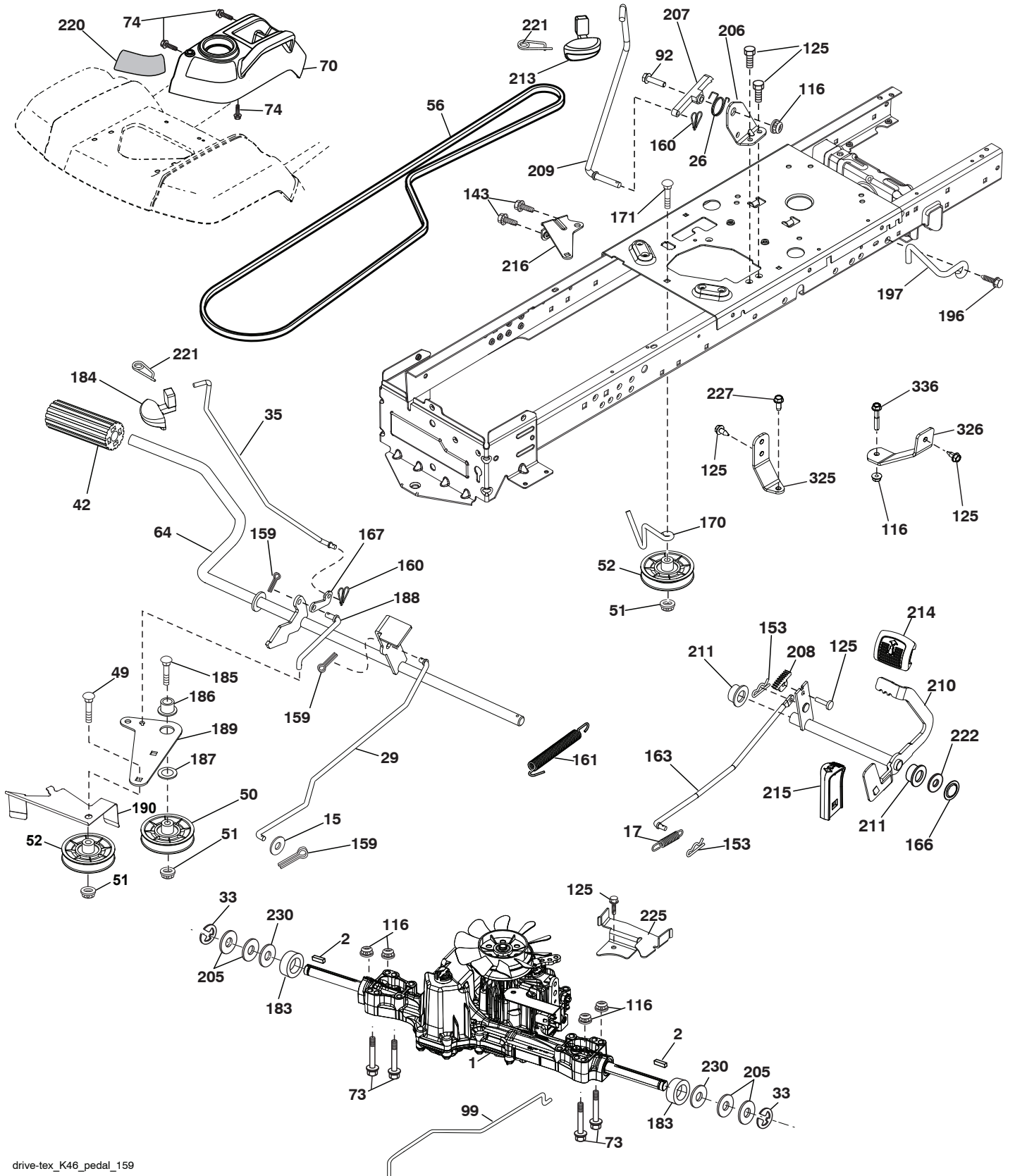

drive-tex_K46_pedal_159

**TRACTOR - MODEL NO. YTH 184T (96041033100), PRODUCT NO. 960 41 03-31
DRIVE **40****

KEY NO.	PART NO.	DESCRIPTION	KEY NO.	PART NO.	DESCRIPTION
1	---	Transaxle, TUFFTORQ K46 BT (426120) (Order parts from trans-axle manufacturer)	184	532 44 14-55	Handle Parking Brake
2	532 12 35-83	Key	185	872 11 06-22	Bolt Rdhd Sqnk 3/8-16 x 2-3/4 Gr. 5
15	819 13 13-16	Washer 13/32 x 13/16 x 16 Ga.	186	532 19 43-21	Spacer Retainer
17	532 41 36-78	Spring Brake	187	819 13 32-10	Washer
26	532 19 96-79	Spring Return Cruise	188	532 19 43-23	Link Clutch Ground Drive
29	532 40 38-06	Rod, Brake	189	532 19 43-17	Bellcrank Ground Drive
33	812 00 00-01	Ring E	190	532 19 43-18	Keeper Bellcrank Ground Drive
35	583 86 45-01	Rod Brake Park	196	817 00 06-16	Screw 3/8-16 x 1
42	532 12 48-72	Cover Foot Pedal	197	585 65 86-01	Link Clutch Anti-Rotation
49	872 11 06-14	Bolt	205	532 12 17-48	Washer
50	532 19 43-27	Pulley Idler Flat	206	532 19 78-67	Bracket Mount Latch
51	873 90 06-00	Lock Nut 3/8-16	207	532 19 78-68	Latch Control
52	532 19 43-26	Idler V-Groove	208	532 19 78-69	Gear Sector Control
56	532 13 09-69	V-Belt Drive	209	532 19 95-92	Rod Control Cruise
64	532 19 78-65	Shaft Asm. Pedal Brake Control	210	532 19 78-60	Rocker Asm. Pedal
70	532 43 96-61	Console Asm.	211	532 12 01-83	Bushing Brake Shaft
73	874 49 05-40	Bolt 5/16-18 x 2-1/2 Gr. 5	213	532 40 31-19	Knob Control Cruise
74	532 14 24-32	Screw 1/4 x 1/2	214	532 42 12-63	Pedal Forward
92	874 76 05-20	Bolt 5/16-18 unc x 1.25	215	532 40 17-23	Pedal Reverse
99	532 41 57-42	Rod Bypass	216	532 19 61-31	Bracket Pulley Idler
116	873 90 05-00	Nut Lock Hex Flange 5/16-18	220	532 19 89-08	Reflector RH
125	817 00 05-12	Screw 5/16-18 x 3/4	221	532 40 31-87	Retainer Spring Clip Handle
143	817 49 05-08	Screw 5/16-18 x 1/2	222	879 21 20-10	Washer 21/32 x1-1/4 10 Ga.
153	532 12 47-88	Retainer Spring	225	532 40 33-19	Keeper Belt Trans.
159	876 02 04-12	Pin Cotter 1/8 x 3/4	227	817 49 05-12	Screw 5/16-18 x 3/4
160	532 16 94-84	Retainer Clip	230	532 18 89-67	Washer Hardened
161	532 10 57-09	Spring Return Clutch	325	585 66 85-02	Bracket
163	532 44 82-75	Rod Control Pedal	326	585 67 08-02	Bracket
166	532 42 91-64	Nut Push	336	587 25 96-01	Bolt
167	532 40 52-57	Latch Brake Parking			
170	532 19 43-22	Keeper Belt Centerspan			
171	872 11 06-16	Bolt RDHD SQNK 3/8-16 unc x 2			
183	532 13 70-57	Spacer Split			

NOTE: All component dimensions given in U.S. inches
1 inch = 25.4 mm

**TRACTOR - MODEL NO. YTH 184T (96041033100), PRODUCT NO. 960 41 03-31
ENGINE [24]**

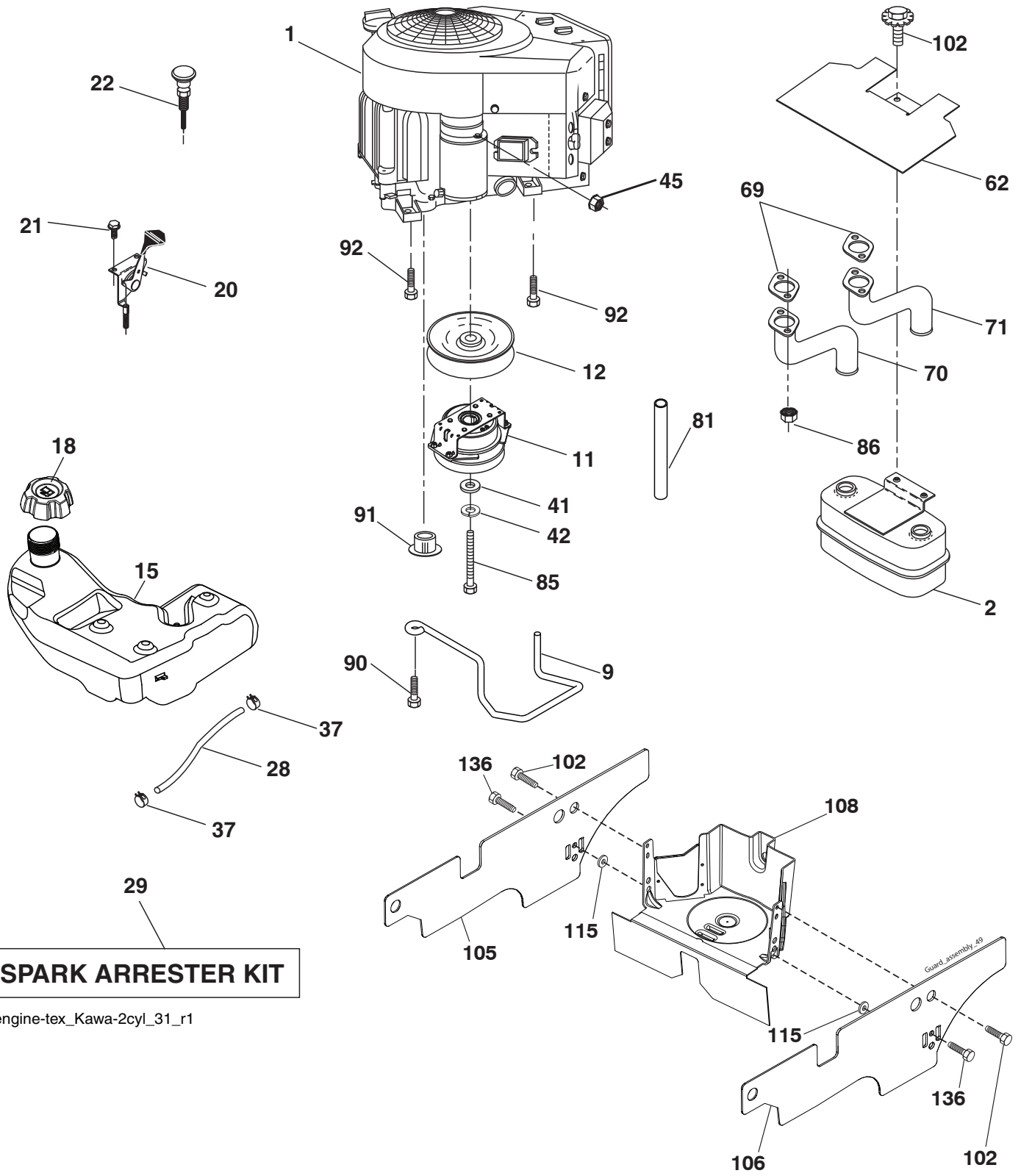

SPARK ARRESTER KIT

engine-tex_Kawa-2cyl_31_r1

**TRACTOR - MODEL NO. YTH 184T (96041033100), PRODUCT NO. 960 41 03-31
ENGINE 24**

KEY NO.	PART NO.	DESCRIPTION
1	- - - - -	Engine Kawa Model No. FS541V-CS51 (445366) (Order parts from engine manufacturer)
2	532 44 59-62	Muffler
9	532 19 43-20	Keeper Belt Engine
11	587 24 15-01	Clutch Electric
12	532 40 50-97	Pulley Engine
15	532 19 34-99	Tank Fuel 4.0
18	532 43 96-45	Cap Asm
20	532 41 21-65	Control Throttle
21	532 41 63-58	Screw #10 x 0.75 BOS Thread
22	532 19 15-96	Control Choke
28	532 14 21-58	Fuel Line
29	532 13 71-80	Spark Arrester Kit
37	532 12 34-87	Clamp Hose
41	532 12 61-97	Washer 1-1/2 OD x 15/32 ID x .250
42	810 04 07-00	Washer Lock 7/16
45	873 51 04-00	Nut Keps Hex 1/4-20 unc
62	532 43 40-17	Shield Heat Muffler
69	532 17 81-51	Gasket
70	532 42 47-65	Tube Exhaust LH
71	532 42 47-66	Tube Exhaust RH
81	532 14 84-56	Tube Drain Oil Easy
85	581 33 28-04	Bolt 7/16-20 x 3.5 Gr. 5
86	532 18 43-62	Nut Hex Flange Toplock M8-1.2
90	817 00 06-16	Screw 3/8-16 x 1
91	532 18 74-95	Bushing
92	817 12 06-16	Screw 3/8-16 x 1
102	817 00 05-12	Screw 5/16-18 x 3/4
105	532 41 05-28	Shield LH
106	532 41 05-29	Shield RH
108	532 42 17-94	Cover, Asm
115	532 42 30-62	Palnut 1/4
136	532 13 77-29	Screw Thd Roll 1/4-20 x 5/8

NOTE: All component dimensions given in U.S. inches
1 inch = 25.4 mm

TRACTOR - MODEL NO. YTH 184T (96041033100), PRODUCT NO. 960 41 03-31
STEERING ASSEMBLY **41**

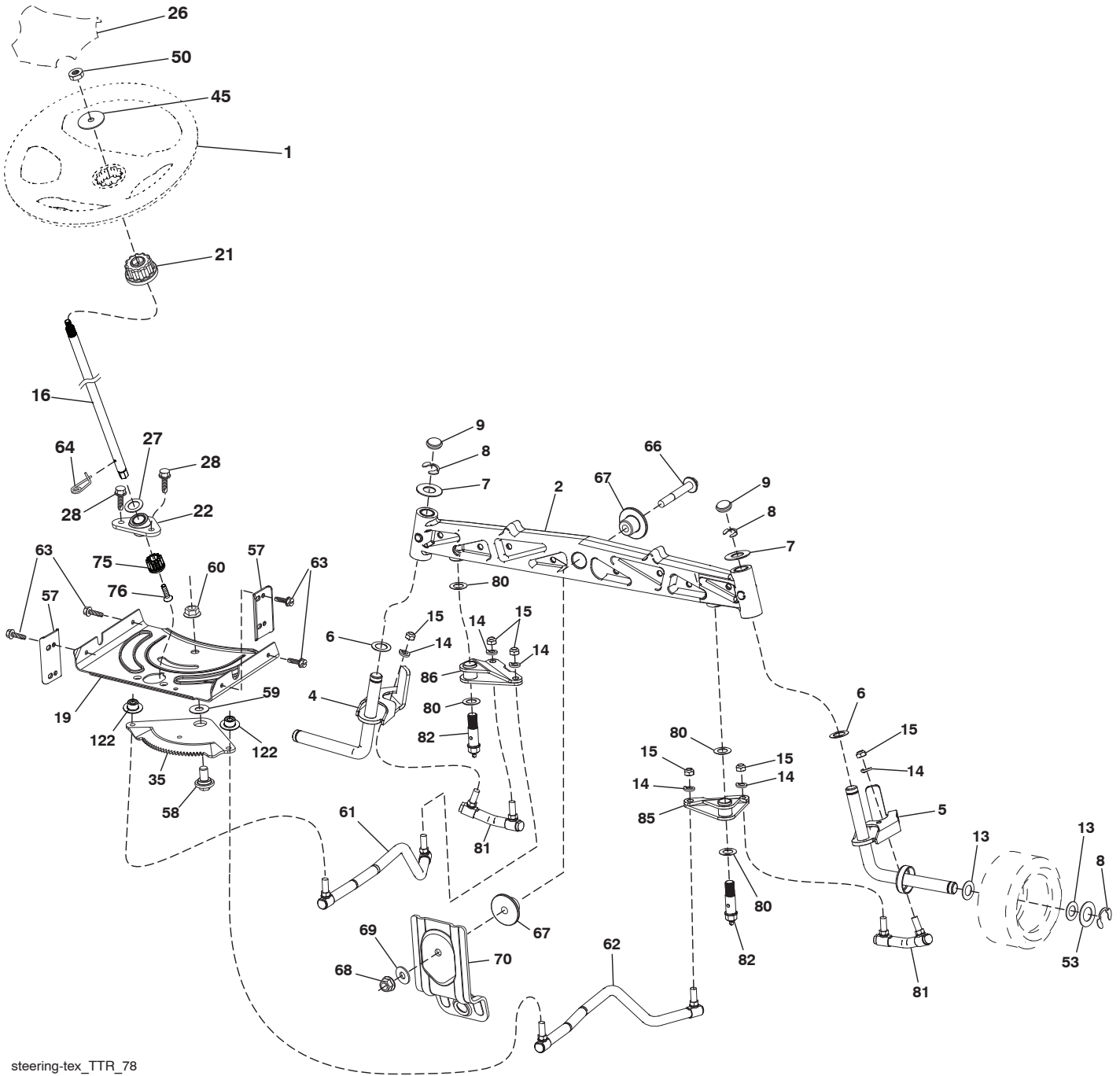

steering-tex_TTR_78

**TRACTOR - MODEL NO. YTH 184T (96041033100), PRODUCT NO. 960 41 03-31
STEERING ASSEMBLY **41****

KEY NO.	PART NO.	DESCRIPTION
1	532 43 97-40	Wheel, Steering
2	532 43 68-70	Axle Cast Iron
4	532 43 68-73	Spindle Asm., LH
5	532 43 68-74	Spindle Asm., RH
6	532 12 49-31	Washer, Thrust
7	532 12 17-48	Washer 25/32 x 1-5/8 x 16 Ga.
8	812 00 00-29	Ring, Klip #T5304-75
9	532 12 12-32	Cap, Spindle
13	532 12 17-49	Washer 25/32 x 1-1/4 x 16 Ga.
14	810 04 06-00	Washer, Lock Hvy Hlcl Spr 3/8
15	873 54 06-00	Nut, Crown Lock 3/8-24 unf
16	587 01 60-02	Steering Shaft
19	532 19 47-29	Plate Steering
21	532 43 77-47	Adapter, Wheel Steering
22	585 02 99-01	Bearing Shaft
26	532 43 97-43	Insert, Wheel Steering
27	819 21 16-16	Washer 21/32 x 1 x 16 Ga.
28	817 00 06-12	Screw 3/8-16 x 3/4
35	532 44 07-70	Gear, Sector Plate
45	819 18 38-12	Washer 9/16 ID x 2-3/8 OD 12 Ga.
50	873 90 06-00	Nut Lock Flg 3/8-16 unc
53	532 18 89-67	Washer Hardened .793 x 1.637 x .060
57	532 40 74-65	Bracket Upstop
58	532 19 47-47	Bolt Shoulder Sector Pivot CFM
59	532 19 47-48	Washer Thrust Sector Steering
60	873 97 10-00	Nut Flange Lock 5/8-11
61	532 43 68-84	Draglink, LH
62	532 43 68-85	Draglink, RH
63	817 00 05-12	Screw 5/16-18 x 3/4
64	532 19 98-49	Retainer Clip Spring Steering
66	871 02 07-48	Bolt Hex Fghd 7/16-14 x 3 Serr
67	532 19 47-37	Bushing PM Front Axle
68	873 90 07-00	Nut Lock Flange 7/16-14 Gr. 5
69	532 19 91-62	Washer 1.5 x .505 x .118
70	532 19 61-97	Bracket Deck Susp. Front
75	580 68 37-01	Pinion
76	580 68 36-01	Screw Head Sock
80	532 00 13-70	Washer 5/8 x 1.10 x 1/32
81	532 43 68-87	Sub Asm. Link Cross
82	532 43 68-77	Sub Asm. Pivot Bolt
85	532 44 18-73	Sub Asm. Pivot RH
86	532 44 18-72	Sub Asm. Pivot LH
122	532 44 49-62	Cap Gear Sector

NOTE: All component dimensions given in U.S. inches
1 inch = 25.4 mm

TRACTOR - MODEL NO. YTH 184T (96041033100), PRODUCT NO. 960 41 03-31
MOWER DECK **44**

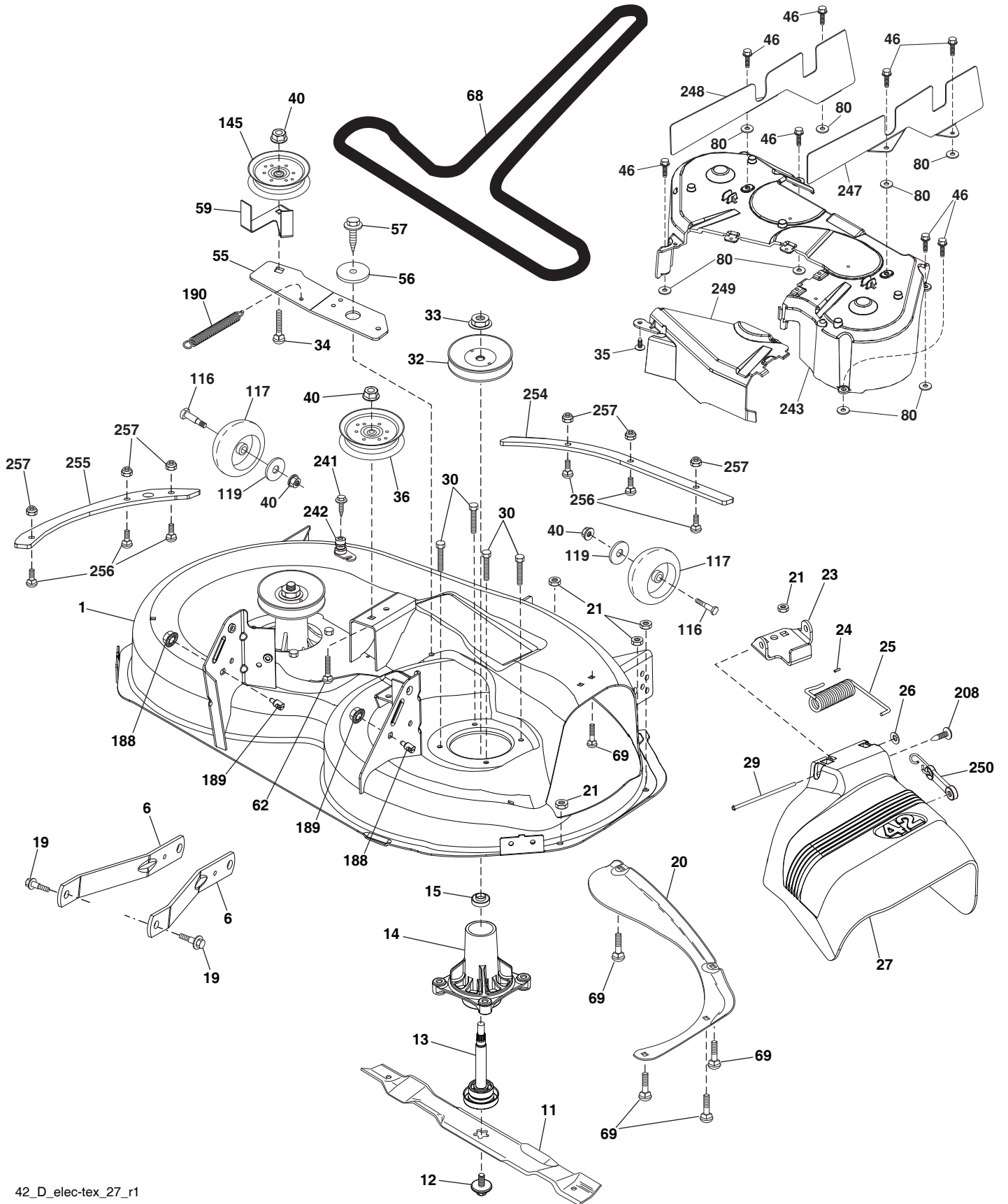

42_D_elec-tex_27_r1

**TRACTOR - MODEL NO. YTH 184T (96041033100), PRODUCT NO. 960 41 03-31
MOWER DECK 44**

KEY NO.	PART NO.	DESCRIPTION	KEY NO.	PART NO.	DESCRIPTION
1	584 92 75-01	Mower Deck Assembly, 42"	116	532 12 48-42	Bolt, Shoulder
6	532 19 51-86	Arm Susp. Rear	117	532 18 86-06	Wheel, Gauge
11	532 13 89-71	Blade Mower 42"	119	819 12 14-14	Washer 3/8 x 7/8 x 14 Ga.
12	584 30 93-01	Screw 7/16-20 x 1 Hex	145	532 19 31-97	Pulley Idler Primary
13	587 25 65-01	Shaft Assembly, Mandrel	188	532 19 51-61	Stud Fastner w/D Anti-Rotation
14	532 18 72-81	Housing, Mandrel	189	873 90 05-00	Nut Lock Hex Flange 5/16-18
15	585 32 39-01	Bearing, Mandrel	190	532 19 72-51	Spring Mower Drive
19	532 19 65-39	Bolt, Shoulder	208	817 67 06-08	Screw 3/8-16 x 1/2
20	532 15 97-70	Baffle, Vortex	241	532 15 29-27	Screw TT #10-32.5. 3/8
21	873 68 05-00	Nut	242	532 41 55-98	Port Washout
23	532 19 25-57	Bracket, Deflector Mower 42"	243	532 43 23-94	Cover, Deck
24	532 10 53-04	Cap, Sleeve 80 x 112 Blk Mower	247	532 43 02-61	Shield Deck RH
25	532 19 70-26	Spring, Torsion, Deflector	248	532 43 02-60	Shield Deck LH
26	532 11 04-52	Nut, Push Phos & Oil	249	532 40 65-14	Cover, Cable Clutch
27	532 41 14-85	Shield, Deflector 42" Blk	250	532 43 60-87	Kit Bungee
29	532 13 14-91	Rod, Hinge 42" 6 75 W/G	254	581 96 75-02	Reinforcement Plate Front
30	532 17 39-84	Screw Thdrol	255	581 96 76-02	Reinforcement Plate Side
32	532 15 35-35	Pulley, Mandrel	256	539 10 98-00	Carriage Bolt 1/4-20 x 1 Gr. 5
33	532 40 02-34	Nut, Toplock	257	873 90 04-00	Nut 1/4-20 unc
34	872 11 06-12	Bolt Carr SH 3/8-16 x 1-1/2 Gr. 5	--	587 25 33-01	Mandrel Assembly (Includes hous- ing (key #14), shaft assembly (key #13), and bearing only (key #15) - pulley/nut/washer and blade bolt/ washers not included)
35	532 13 38-35	Fastner			
36	532 19 73-79	Pulley, Idler, Flat			
40	873 90 06-00	Nut Lock 3/8-16			
46	532 13 77-29	Screw 1/4-20 x 5/8			
55	532 43 71-10	Arm, Idler	--	583 93 50-03	Replacement Mower, Complete (Std. deck Order separately gauge wheel components Key Nos. 116-119)
56	532 19 90-92	Spacer, Retainer			
57	817 00 06-16	Screw 3/8-16 x 1			
59	532 14 10-43	Guard TUV Idler			
62	872 11 06-16	Bolt Rdhd Sqnk 3/8-16 unc x 2			
68	532 14 49-59	V-Belt, 42" Mower			
69	872 14 05-05	Bolt, Carriage 5/16-18 x 5/8			
80	532 42 30-62	Palnut 1/4			

NOTE: All component dimensions given in U.S. inches
1 inch = 25.4 mm

TRACTOR - MODEL NO. YTH 184T (96041033100), PRODUCT NO. 960 41 03-31
MOWER LIFT 45

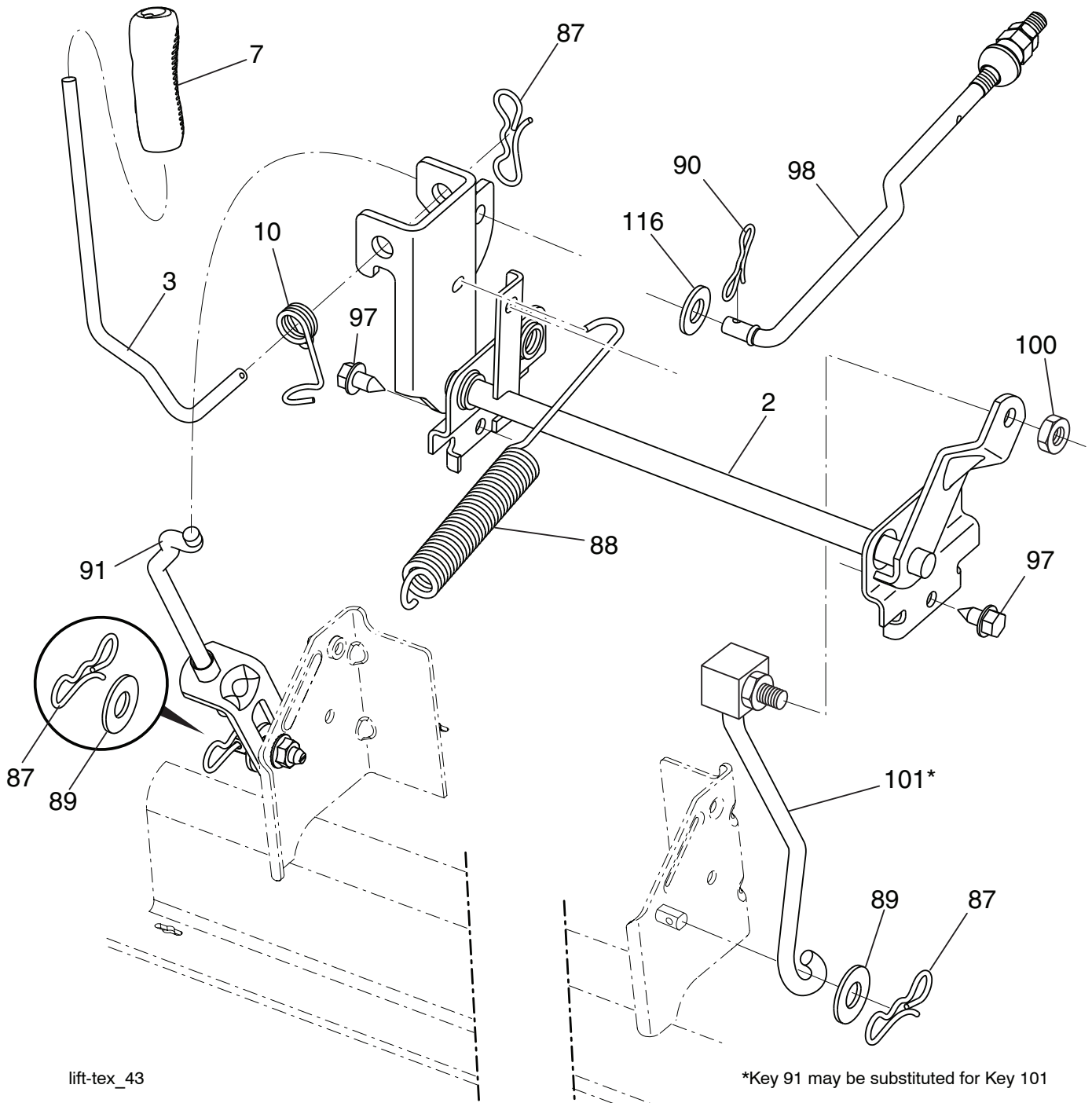

KEY NO.	PART NO.	DESCRIPTION
2	532 42 20-27	Shaft Asm., Lift
3	532 19 52-30	Lever Asm., Lift RH
7	580 96 23-01	Grip, Lever
10	532 19 63-14	Spring Torsion
87	532 19 42-09	Pin Cotter 7/16 Bow Tie Lock
88	532 41 07-10	Spring Lift Assist
89	819 19 19-12	Washer Clear Zinc
90	532 19 42-08	Pin Cotter 5/16 Bow Tie Lock
91	532 19 51-81	Link Lift Susp Mower Rear

KEY NO.	PART NO.	DESCRIPTION
97	817 00 06-12	Screw 3/8-16 x .75 Smgml Tap/R.Z
98	532 19 52-70	Link Lift Susp. Front Mower
100	873 93 06-00	Nut Lock 3/8 - 16 unc
101	532 40 70-03	Link Asm. Lift Fxd
116	819 15 15-16	Washer 15/32 x 15/16 x 16 Ga.

NOTE: All component dimensions given in U.S. inches
 1 inch = 25.4 mm

**TRACTOR - MODEL NO. YTH 184T (96041033100), PRODUCT NO. 960 41 03-31
SEAT ASSEMBLY 42**

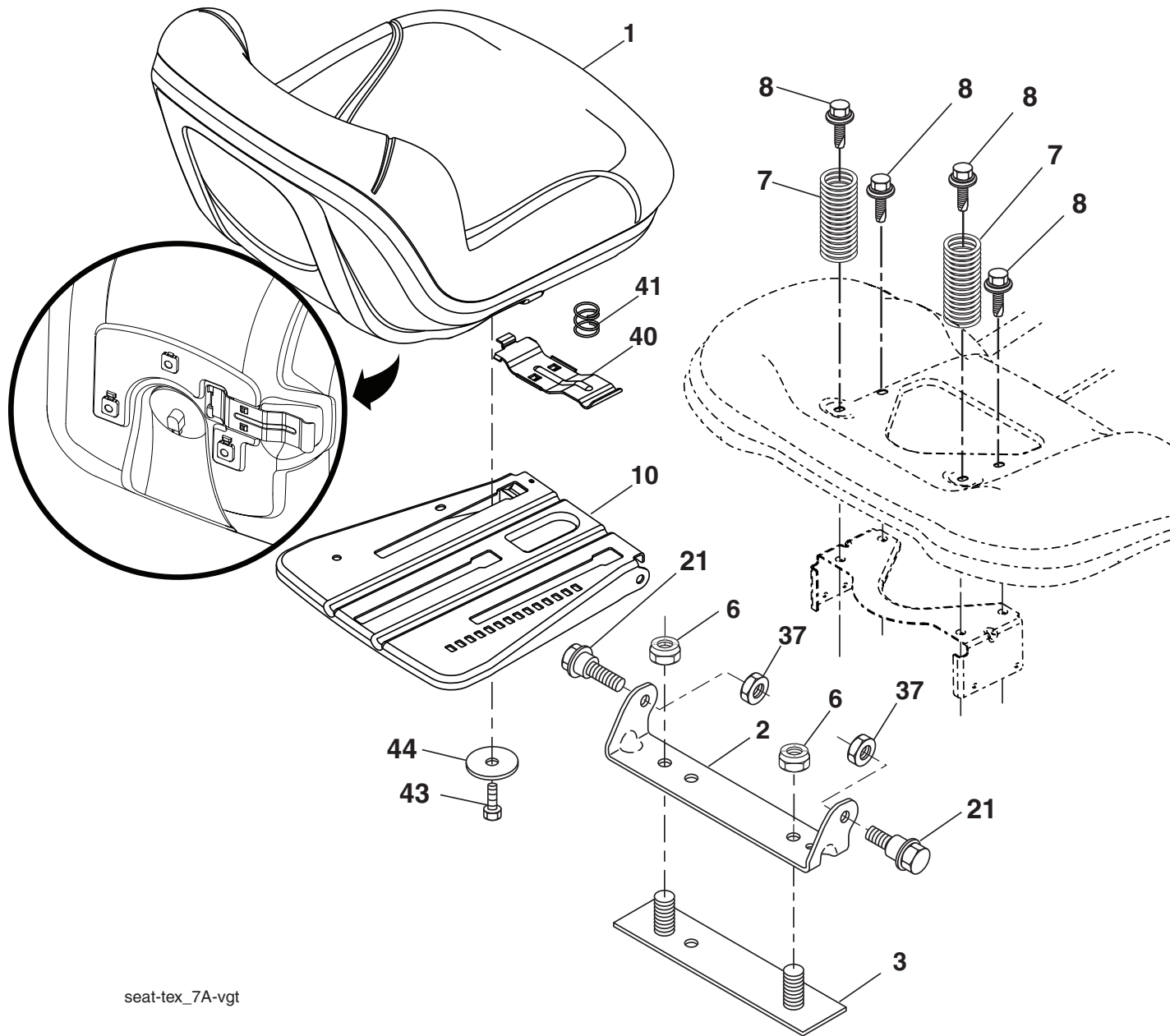

seat-tex_7A-vgt

KEY NO.	PART NO.	DESCRIPTION
1	532 43 98-22	Seat
2	532 18 01-66	Bracket Pivot Fender
3	532 14 06-75	Strap, Asm Fender
6	873 80 06-00	Nut, Lock w/Ins. 3/8-16 unc
7	532 12 41-81	Spring, Seat Cprsn
8	532 17 18-77	Bolt 5/16-18 unc x 3/4 w/Sems
10	532 19 69-77	Pan, Seat
21	532 17 18-52	Bolt, Shoulder 5/16-18
37	873 80 05-00	Nut, Lock 5/16-18 unc

KEY NO.	PART NO.	DESCRIPTION
40	532 19 76-61	Handle Slide Seat
41	532 19 82-00	Spring Latch Seat
43	874 76 06-12	Bolt 3/8-16 x 3/4
44	819 13 38-12	Washer 13/32 x 2-3/8 x 12 Ga.

NOTE: All component dimensions given in U.S. inches
1 inch = 25.4 mm

