

ILLUSTRATED PARTS LIST

MODEL NO. 96051010400

CUSTOMER CATALOG NO. CT 154

PRODUCT NO. 960 51 01 04

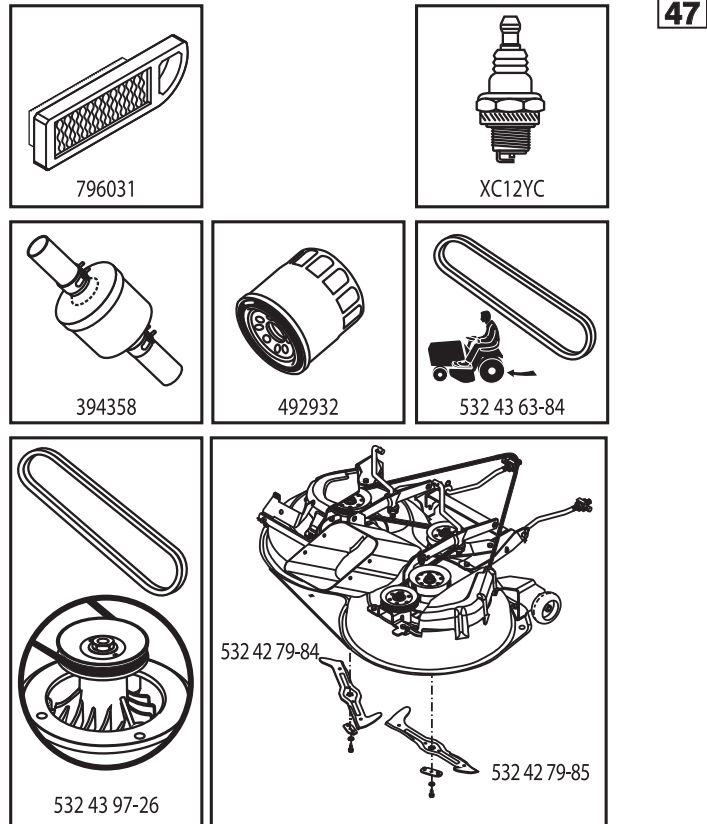

586181101

TRACTOR - - MODEL NO. CT 154 (96051010400), PRODUCT NO. 960 51 01 04
DECALS 27

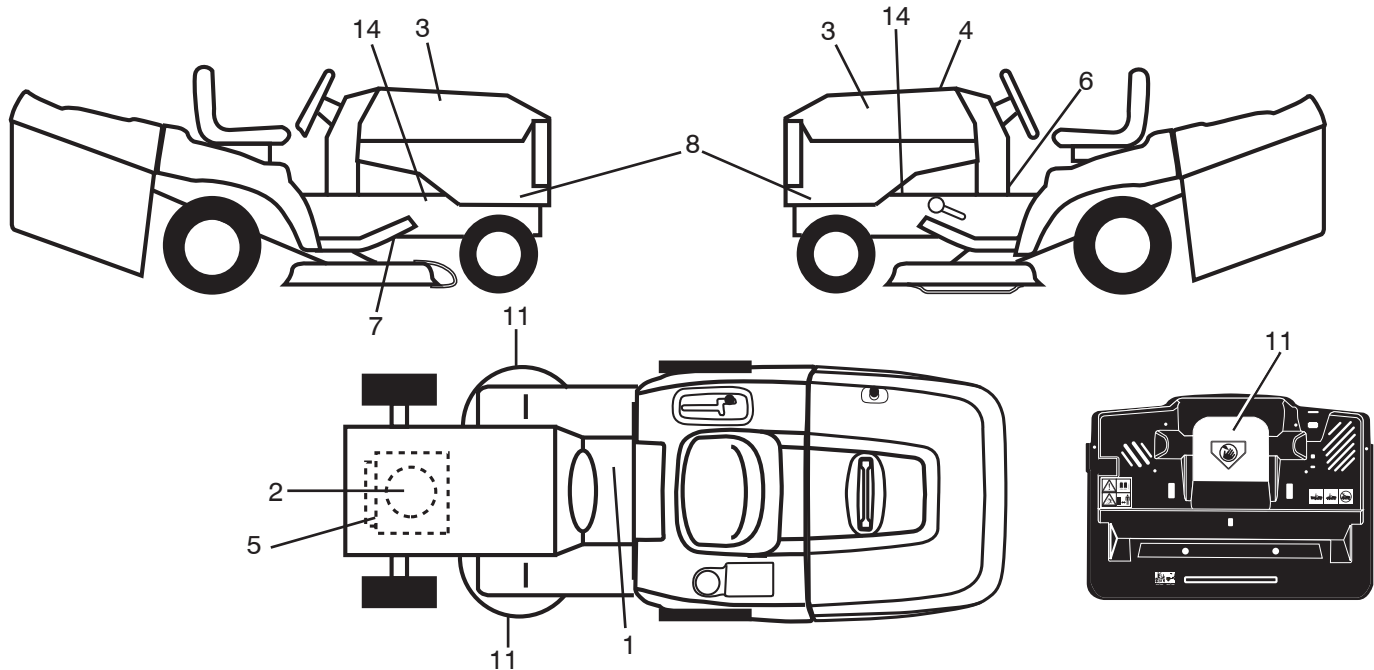

KEY NO.	PART NO.	DESCRIPTION
1	581 57 83-01	Decal, Warning
2	581 57 97-01	Decal, Warning Eng. Sym.
3	581 62 73-01	Decal, Hood
4	586 18 11-01	Decal, Replacement
5	586 08 14-01	Decal, Engine
6	586 06 62-01	Decal, Snowflake
7	532 44 11-89	Decal, Deck Belt
8	532 44 77-60	Decal, Side Panel
11	581 57 91-01	Decal, Mower Cut Finger Symbol
14	581 57 96-01	Decal, Chassis Hot Muffler

KEY NO.	PART NO.	DESCRIPTION
--	532 44 27-44	Decal, Battery Door
--	532 18 04-35	Decal, Backplate Symb.
--	532 44 32-61	Decal, Inst. Mulch Plug
--	532 44 14-09	Pad Footrest LH
--	532 44 18-02	Pad Footrest RH
--	586 18 82-40	Manual Operator's (Euro)
--	586 18 82-50	Manual Operator's (Scan)
--	586 18 82-20	Manual Operator's (E-Bloc)
--	586 18 82-30	Manual Operator's (Baltic)

WHEELS AND TIRES

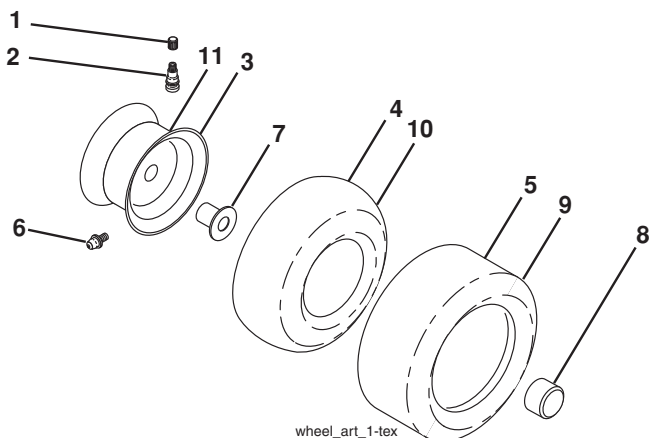

KEY NO.	PART NO.	DESCRIPTION
1	532 05 91-92	Cap Valve Tire
2	532 06 51-39	Stem Valve
3	532 13 83-36	Rim Front
4	532 05 99-04	Tube Front (Service Item Only)
5	532 10 62-22	Tire Front 15 x 6.0-6
6	532 12 49-57	Fitting Grease (Front Wheel Only)
7	532 12 49-59	Bearing Flange (Front Wheel Only)
8	532 17 50-39	Cap Axle Blk 1 50 x 1 00
9	532 42 05-31	Tire Rear 18 x 9.5-8
10	532 12 49-26	Tube Rear (Service Item Only)
11	532 13 83-37	Rim Asm 8" Rear
--	532 14 43-34	Sealant, Tire (10 oz. Tube)

NOTE: All component dimensions given in U.S. inches
 1 inch = 25.4 mm

TRACTOR - - MODEL NO. CT 154 (96051010400), PRODUCT NO. 960 51 01 04

SCHEMATIC **38**

SCH17

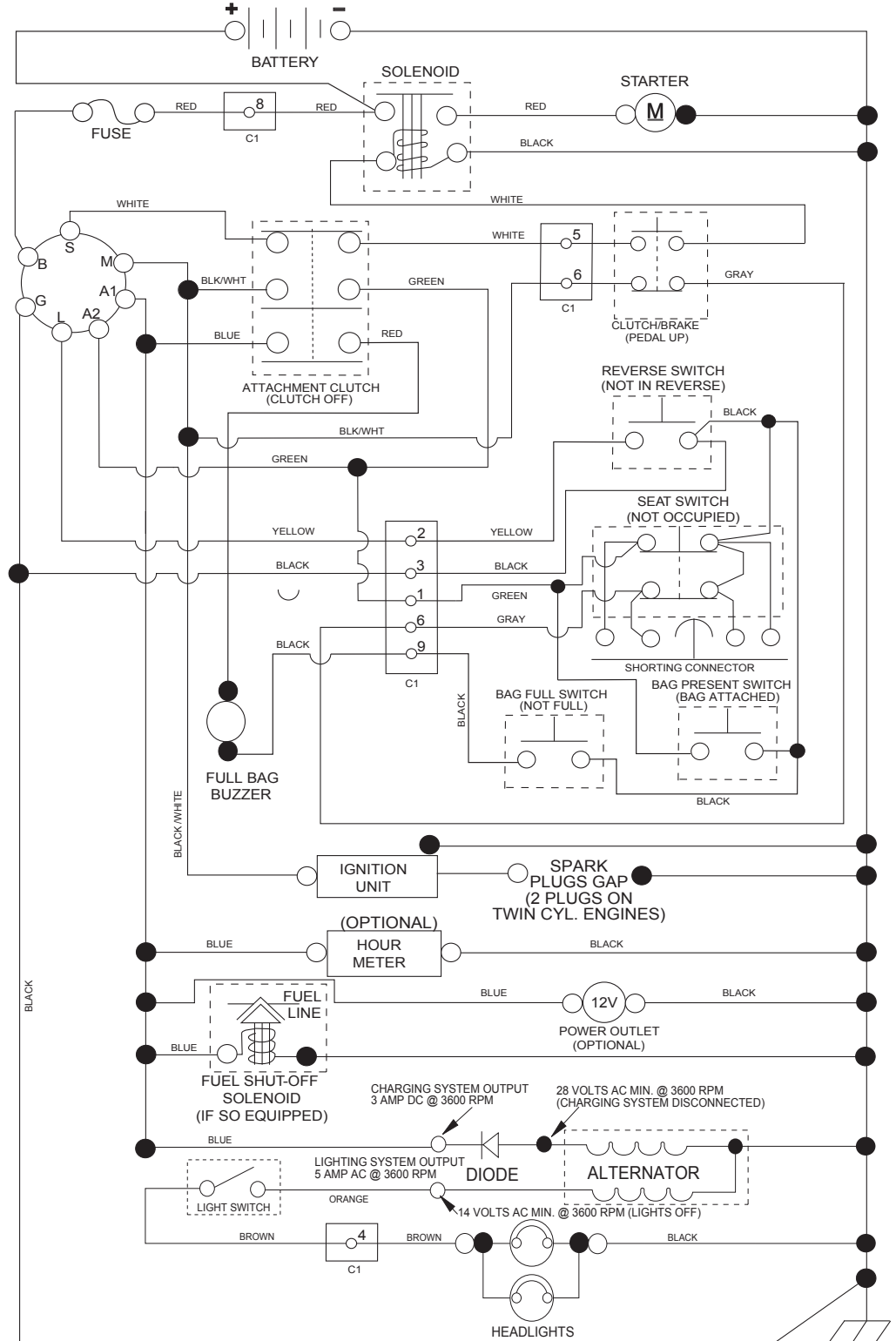

NOTE
 YOUR TRACTOR IS EQUIPPED WITH A SPECIAL ALTERNATOR SYSTEM. THE LIGHTS ARE NOT CONNECTED TO THE BATTERY, BUT HAVE THEIR OWN ELECTRICAL SOURCE. BECAUSE OF THIS, THE BRIGHTNESS OF THE LIGHTS WILL CHANGE WITH ENGINE SPEED. AT IDLE THE LIGHTS WILL DIM. AS THE ENGINE SPEED IS INCREASED, THE LIGHTS WILL BECOME THEIR BRIGHTEST.

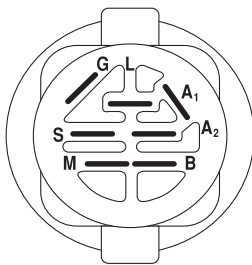

IGNITION SWITCH

POSITION	CIRCUIT "MAKE"
OFF	M+G+A1
RUN/OVERRIDE	B+A1
RUN	B+A1 L+A2
START	B + S + A1

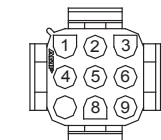

CHASSIS HARNESS CONNECTOR (C1) (MATING SIDE)

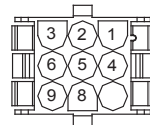

DASH HARNESS CONNECTOR (C1) (MATING SIDE)

WIRING INSULATED CLIPS
 NOTE: IF WIRING INSULATED CLIPS WERE REMOVED FOR SERVICING OF UNIT, THEY SHOULD BE RE-INSTALLED TO PROPERLY SECURE YOUR WIRING.

NON-REMOVABLE CONNECTIONS

REMOVABLE CONNECTIONS

TRACTOR - - MODEL NO. CT 154 (96051010400), PRODUCT NO. 960 51 01 04
 ELECTRICAL **32**

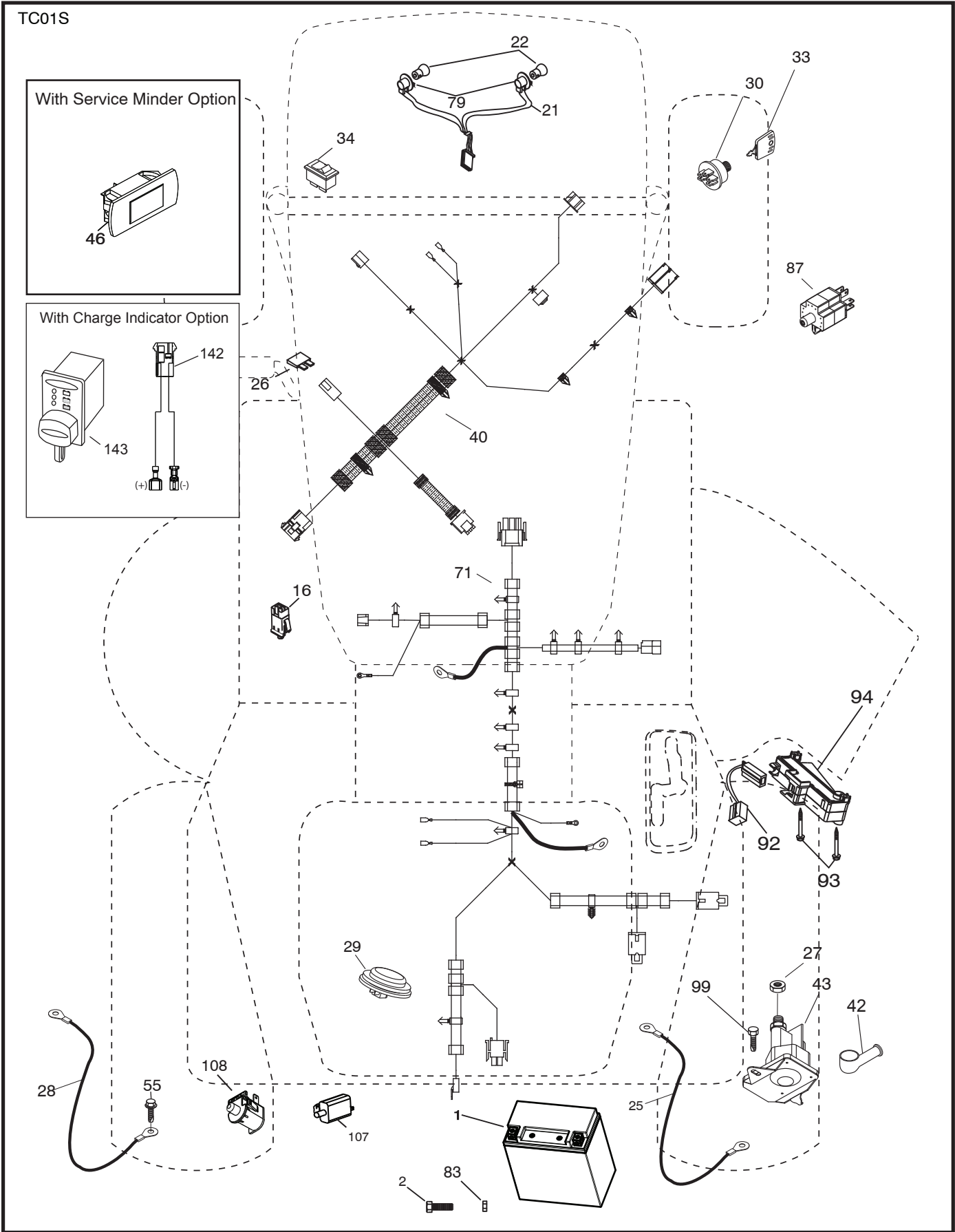

TRACTOR - - MODEL NO. CT 154 (96051010400), PRODUCT NO. 960 51 01 04
ELECTRICAL 32

KEY NO.	PART NO.	DESCRIPTION
1	532 43 71-57	Battery
2	532 44 09-23	Screw Hex Head Cap M6 x 1.12 mm
16	532 17 61-38	Switch Interlock Push-In
21	532 40 02-52	Harness Socket Light w/4152J
22	532 00 41-52	Bulb Light
25	581 48 98-01	Cable Starter
26	532 17 51-58	Fuse
27	873 51 04-00	Nut Keps Hex 1/4-20 unc
28	581 48 98-02	Cable, Ground
29	532 40 15-45	Switch, Seat
30	532 19 33-50	Switch, Ign.
33	532 41 19-35	Key/Chain
34	532 11 07-12	Switch Light/Reset
40	585 84 99-01	Harness Ign. Dash
42	532 13 15-63	Battery Boot
43	532 19 25-07	Solenoid
55	817 06 05-12	Screw Thdrol. 5/16-18 x 3/4 TYTT
71	585 84 97-01	Harness Chassis
79	532 17 52-42	Socket Asm. Bulb Twistlock
83	532 43 67-74	Nut Square M6 x 1.8.5 x 11 mm
87	532 42 10-60	Switch Interlock Clutch Cable
92	532 19 66-15	Harness Pigtail Reverse Switch
93	532 19 25-40	Screw Plastite 10-14 x 2.0
94	532 19 18-34	Module Reverse ROS
99	817 72 04-08	Screw Thd. Cut 1/4-20 x 1/2
107	532 18 03-79	Switch Full Bagger Indicator
108	532 42 10-62	Switch Snapmount
142	583 85 78-01	Charge Port Pigtail
143	532 44 80-59	Charge Port

NOTE: All component dimensions given in U.S. inches
1 inch = 25.4 mm

TRACTOR - - MODEL NO. CT 154 (96051010400), PRODUCT NO. 960 51 01 04
CHASSIS AND ENCLOSURES **39**

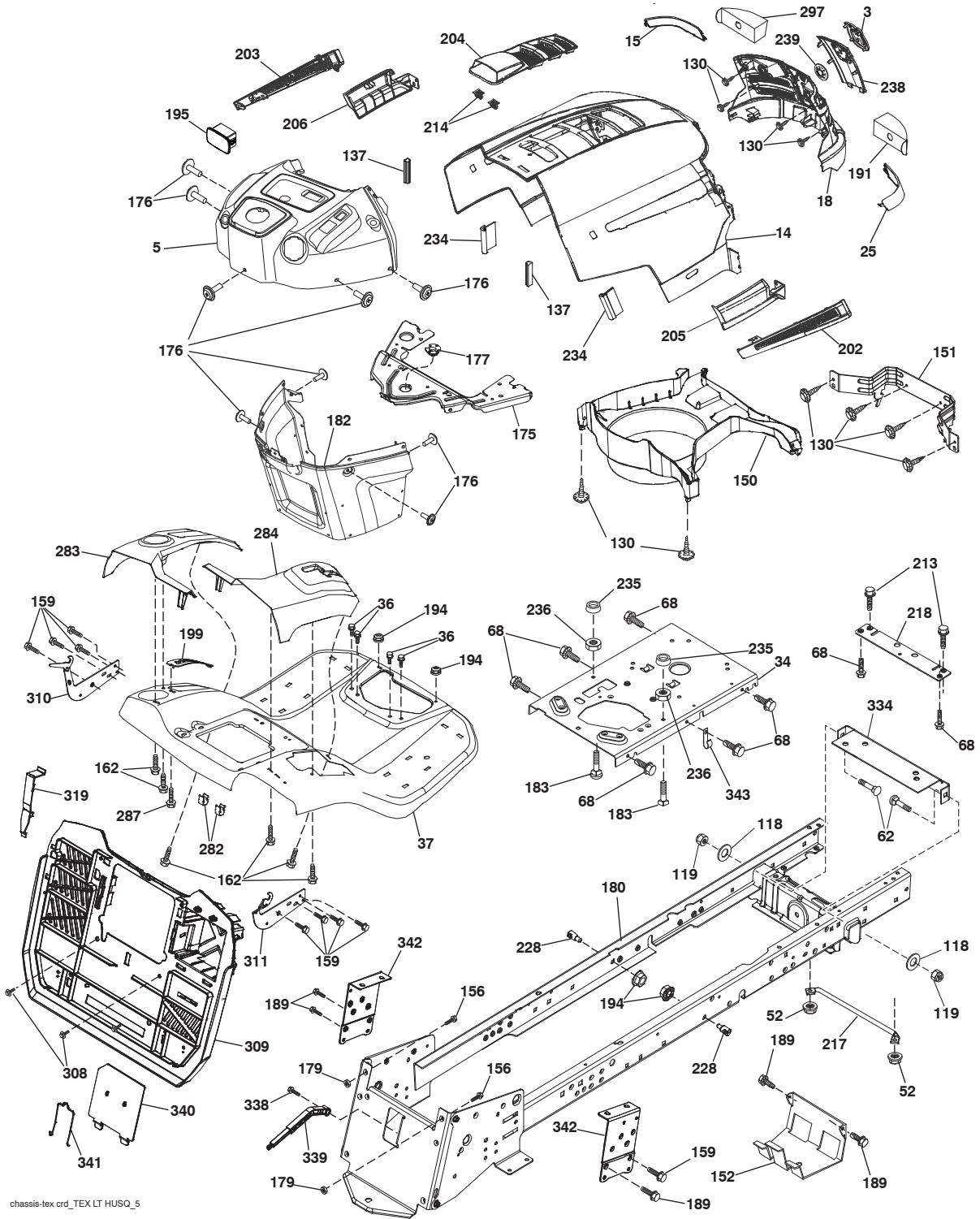

chassis-tex crd_TEX LT HUSQ_5

**TRACTOR - - MODEL NO. CT 154 (96051010400), PRODUCT NO. 960 51 01 04
CHASSIS AND ENCLOSURES 39**

KEY NO.	PART NO.	DESCRIPTION	KEY NO.	PART NO.	DESCRIPTION
3	581 05 63-01	Logo	203	532 44 13-43	Vent Side Hood LH
5	585 52 98-06	Dash	204	532 44 13-75	Vent Top Hood
14	532 44 12-67	Hood	205	532 44 13-44	Skirt Side RH
15	532 44 14-28	Lens LH	206	532 44 13-45	Skirt Side LH
18	532 44 13-68	Grille	213	874 76 05-12	Bolt Hex HD 5/16-18 unc 3/4
25	532 44 14-27	Lens RH	214	532 19 91-45	Clip Retainer
34	580 91 09-01	Plate Engine	217	532 40 91-67	Rod Pivot Hood
36	817 06 05-12	Screw 5/16-18 x 3/4	218	532 19 63-95	X-Piece Hood Stop
37	532 44 14-19	Fender	228	532 19 51-61	Stud Fastener
52	873 68 05-00	Nut Crownlock 5/16-18	234	532 40 47-42	Bumper Hood
62	872 11 06-08	Bolt RDHD SQNK 3/8-16 X 1Gr. 5	235	532 40 61-29	Spacer Fender
68	817 49 05-08	Screw Thdrol. 5/16-18 x 1/2	236	873 93 05 00	Nut Center Lock 5/16-18 unc
118	819 13 13-16	Washer 13/32 x 13/16 x 16 Ga.	238	532 44 13-74	Trim
119	873 68 06-00	Nut Crownlock 3/8-16 unc	239	532 40 48-83	Clip Tinnerman
130	532 41 63-58	Screw #10 x .750 BOS Thread	282	532 41 41-10	Clip Retainer
137	532 40 75-90	Bumper Dash	283	532 44 05-31	Console Deck Lift
150	532 40 66-62	Air Duct	284	532 44 08-59	Console Shift RH
151	532 40 78-07	Bracket Pivot	287	817 60 04-06	Screw Hex Washhead. 1/4-20 x 3/8
152	532 19 95-35	Shield Browning	297	532 40 66-65	Insert Reflective LH
156	872 14 06-14	Bolt 3/8-16 unc x 1-3/4	308	532 17 18-77	Bolt 5/16-18 unc x 3/4
159	817 00 06-12	Screw 3/8-16 x 3/4	309	584 44 11-01	Backplate
162	532 14 24-32	Screw Hex Wsh. Hi-Lo 1/4 x 1/2 unc	310	532 44 66-36	Bracket Hangbar Bag LH
175	532 19 94-72	Crossmember	311	532 44 66-37	Bracket Hangbar Bag RH
176	532 40 07-76	Screw 10-24 x 5/8	319	532 17 46-62	Bracket Actuator Bagger
177	532 19 52-28	Bushing Steering	334	532 44 25-37	Bracket Engine
179	532 16 89-37	Nut Push	338	532 43 66-40	Bolt Shoulder
180	581 18 71-01	Chassis	339	532 43 66-41	Lever Bagger Full
182	532 40 71-76	Dash Lower	340	532 44 09-31	Door Battery Tray
183	874 52 05-20	Bolt 5/16-18 x 1-1/4	341	532 43 66-38	Latch Batter Tray
189	817 00 05-12	Screw 5/16-18 x 3/4	342	532 43 59-38	Support Fender
191	532 41 65-01	Insert Reflective RH	343	532 44 07-49	Clip
194	873 90 05-00	Nut Lock Hex Flange 5/16-18			
195	532 43 99-76	Plug Dash			
199	532 41 87-39	Plate Deck Lift			
202	532 44 13-42	Vent Side Hood RH			

NOTE: All component dimensions given in U.S. inches
1 inch = 25.4 mm

TRACTOR - - MODEL NO. CT 154 (96051010400), PRODUCT NO. 960 51 01 04

DRIVE 40

KEY NO.	PART NO.	DESCRIPTION	KEY NO.	PART NO.	DESCRIPTION
1	---	Transaxle, Peerless 206-578 (436815) (Order parts from transaxle manufacturer.)	167	532 40 52-57	Latch Brake Parking
2	532 12 35-83	Key Square	174	532 19 72-89	Nut Push
6	532 12 40-28	Bushing	183	532 13 70-57	Spacer Axle
15	819 13 13-16	Washer 13/32 x 13/16 x 16 Ga.	184	532 44 14-07	Handle Parking Brake
17	532 44 08-67	Spring, Brake	185	872 11 06-22	Bolt
22	532 44 32-46	Rod Shift CRD Tex	186	532 19 43-21	Spacer Retainer
23	532 12 12-74	Knob Duckhead 1/2-13	189	532 43 36-11	Bellcrank Ground Drive CRD Tex
26	532 14 66-82	Spring Brake Return	192	532 15 03-60	Nut Lock Center 1/4-28 Fnthd.
29	532 43 70-16	Rod, Brake	195	580 45 69-01	Bracket Brake Rod
30	819 13 16-16	Washer	205	532 12 17-48	Washer 25/32 x 1-5/8 16 Ga.
33	812 00 00-01	Ring E	221	532 40 31-87	Retainer Spring Clip Handle
35	532 40 10-31	Rod, Brake, Park	229	817 06 05-16	Screw
37	532 12 17-49	Washer 25/32 x 1-1/4 x 16 Ga.	263	817 00 06-12	Screw
42	532 12 48-72	Cover, Foot Pedal	268	532 18 24-02	Guard Muffler RH
49	872 11 06-14	Bolt	275	819 13 16-14	Washer 13/32 x 1 x 14 Ga.
50	532 19 43-27	Idler Flat	280	819 11 10-12	Washer
51	873 90 06-00	Lock Nut 3/8-16	313	874 78 04-16	Bolt Hex Fin 1/4-20 x 1 Gr. 5
52	532 19 43-26	Pulley Idler V Groove Plastic	314	532 44 47-13	Keeper, Belt
56	532 43 63-84	V-Belt, Drive	315	817 58 05-20	Screw Thdrol 5/16-18 x 4.25
61	532 16 59-99	Pulley Transaxle	318	532 43 70-22	Link Shift Gear
64	532 19 62-00	Shaft Asm. Pedal Brake Control	319	532 43 67-94	Spacer Transaxle Tex CRD
73	874 49 05-56	Bolt Hex 5/16-18 x 3.75	328	532 43 79-58	Shaft Shift Front
78	819 11 12-12	Washer	330	532 16 95-93	Washer Nylon
90	532 44 36-05	Keeper Belt Clutching	331	532 44 36-06	Hub Shift
103	873 35 05-00	Nut	333	532 17 08-68	Wave Spring Washer
116	873 90 05-00	Nut Lock Hex Flange 5/16-18	335	532 19 95-34	Pulley V-Idler
125	817 00 05-12	Screw 5/16-18 x 3/4	337	532 43 59-37	Bracket Supt Shift CRD Tex
126	532 16 60-02	Washer Srrtd 5/16 ID x 1.0 x .125	339	532 43 68-67	Strap Torque K46 CRD Tex
127	532 19 43-23	Link Clutch Ground Drive	340	532 43 68-12	Idler Flat
134	532 14 50-90	Asm. Shift	342	532 18 26-82	Keeper Belt
139	874 55 04-12	Bolt 1/4-28 unf Gr. 8 w/Patch	344	532 43 56-45	Bracket Idler CRD Tex
140	810 04 04-00	Washer Lock Hvy. Helical 1/4	348	532 44 36-07	Bracket Pivot Lever
141	819 09 12-10	Washer 9/32 x 3/4 x 10 Ga.	350	532 44 50-20	Spring Torsion Shift
143	817 49 05-08	Screw Thdrol 5/16-18 x 1/2 TYTT	351	532 43 69-98	Bracket Deck Sway
155	812 00 00-28	Ring Retainer	354	817 49 05-10	Screw
157	532 10 57-01	Washer Plate Shift	357	532 44 13-38	Keeper Belt Transmission
159	876 02 04-12	Cotter Pin	359	817 49 06-10	Screw Hxwsh Thdr 3/8-16 x 5/8
160	532 16 94-84	Retainer Clip	364	532 44 30-32	Bracket
161	532 10 57-09	Spring, Return, Clutch			
165	532 19 62-12	Bushing Shaft Brake Hand Control			
166	532 42 91-64	Nut Push .625			

NOTE: All component dimensions given in U.S. inches
1 inch = 25.4 mm

TRACTOR - - MODEL NO. CT 154 (96051010400), PRODUCT NO. 960 51 01 04
ENGINE **24**

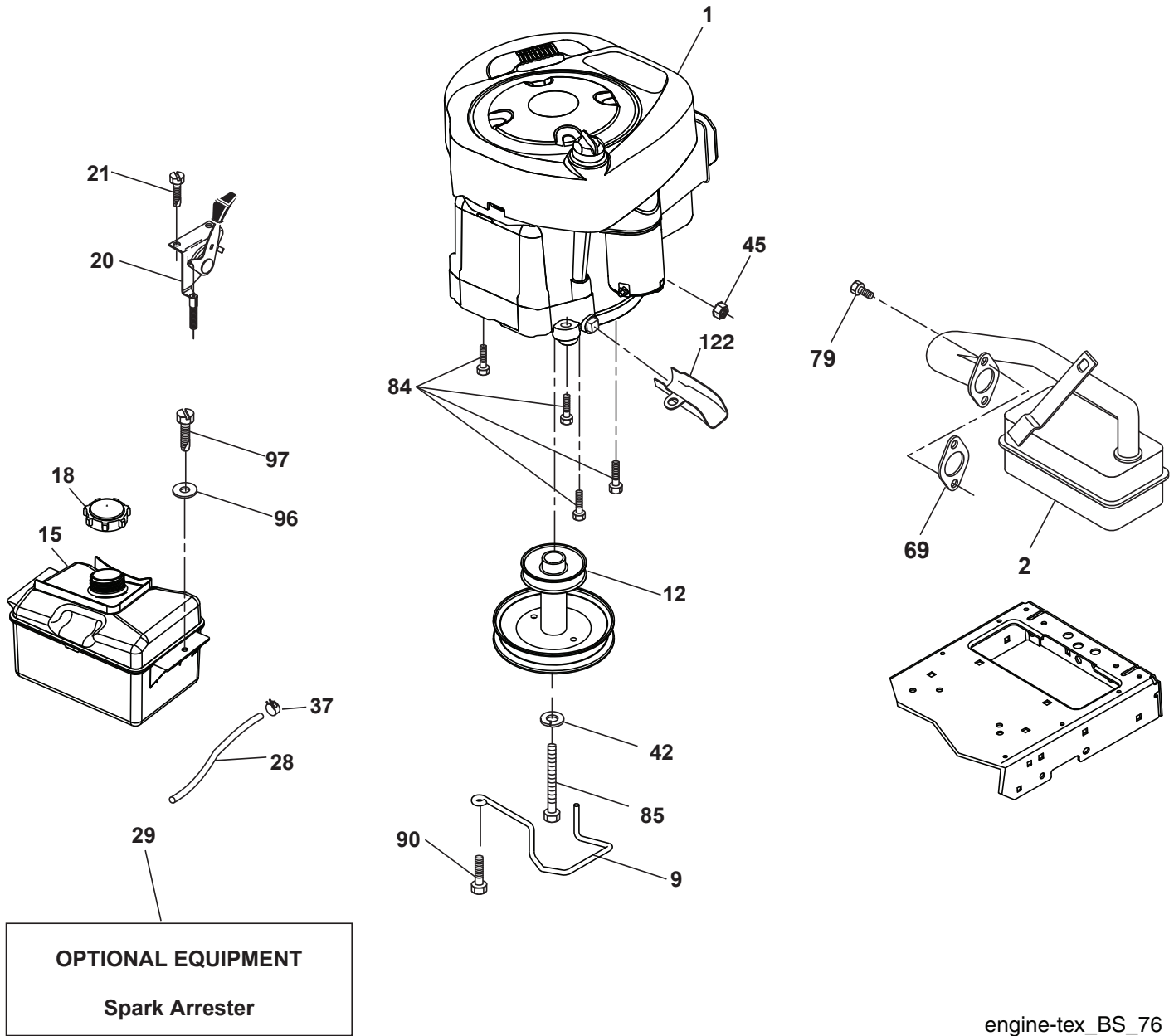

**TRACTOR - - MODEL NO. CT 154 (96051010400), PRODUCT NO. 960 51 01 04
ENGINE 24**

KEY NO.	PART NO.	DESCRIPTION
1	-----	Engine B&S Model No. 31R577-0019-B1 (586063101) (Order parts from engine manufacturer.)
2	532 13 73-52	Muffler
9	584 90 80-01	Keeper Belt Engine
12	586 47 85-01	Pulley Engine
15	581 28 99-01	Tank Fuel 1.5
18	532 43 02-20	Cap Fuel
20	532 18 38-97	Control Throttle
21	532 41 63-58	Screw #10 x 0.750 BOS Thread
28	532 13 70-40	Fuel Line
29	532 13 71-80	Spark Arrester Kit
37	532 12 34-87	Clamp Hose
42	810 04 07-00	Lock Washer Hvy. 7/16
45	873 51 04-00	Nut Keps Hex 1/4-20 unc
69	532 16 52-91	Gasket
79	532 19 23-34	Screw Socket HD 5/16-18 x .75
84	817 06 06-20	Screw 3/8-16 x 1-1/4
85	532 17 39-37	Bolt Hex 7/16-20 x 4 x Gr. 5-1.5 Thr
90	817 00 06-16	Screw 3/8-16 x 1
96	819 09 14-16	Washer 9/32 x 7/8 x 16 Ga.
97	817 67 04-12	Screw 1/4-20 x 3/4
122	532 42 19-22	Extension Drain Oil

NOTE: All component dimensions given in U.S. inches
1 inch = 25.4 mm

TRACTOR - - MODEL NO. CT 154 (96051010400), PRODUCT NO. 960 51 01 04
STEERING ASSEMBLY **41**

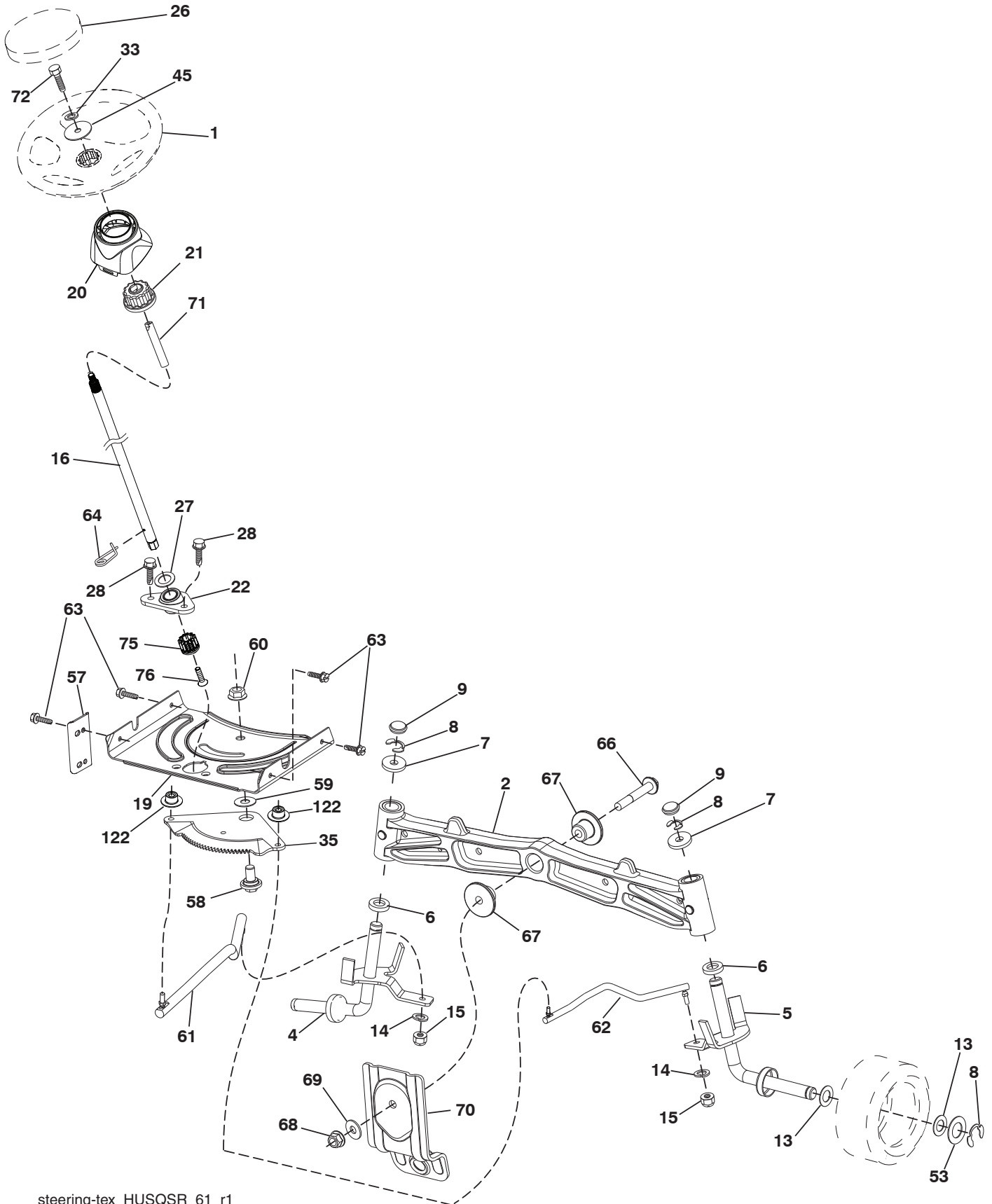

steering-tex_HUSQSR_61_r1

TRACTOR - - MODEL NO. CT 154 (96051010400), PRODUCT NO. 960 51 01 04
STEERING ASSEMBLY 41

KEY NO.	PART NO.	DESCRIPTION
1	532 43 97-40	Wheel, Steering Husq SR
2	532 19 59-68	Axle Asm., Front
4	532 40 30-87	Spindle Asm., LH
5	532 40 30-88	Spindle Asm., RH
6	532 12 49-31	Bearing, Race Thrust Hardened
7	532 12 17-48	Washer 25/32 x 1-5/8 x 16 Ga.
8	812 00 00-29	Ring, Clip #T5304-75
9	532 12 12-32	Cap, Spindle
13	532 12 17-49	Washer 25/32 x 1-1/4 x 16 Ga.
14	810 04 06-00	Washer, Lock Hvy. Hlcl. Spr. 3/8
15	873 54 06-00	Nut, Crown Lock 3/8-24 unf
16	585 86 92-02	Steering Shaft
19	532 19 47-29	Plate Steering
20	532 44 14-25	Boot, Steering
21	532 18 67-37	Adapter, Wheel Steering
22	585 02 98-02	Bearing
26	532 43 97-43	Insert, Wheel Steering Husq SR
27	819 21 16-16	Washer
28	817 00 06-12	Screw 3/8-16 x 3/4
33	810 04 05-00	Washer Lock 5/16
35	532 19 47-32	Gear, Sector Plate
45	819 11 38-12	Washer 11/32 x 3/8 x 12 Ga.
53	532 18 89-67	Washer Hardened .793 x 1.637 x .060
57	532 40 74-65	Bracket Upstop
58	532 19 47-47	Bolt Shoulder Sector Pivot CFM
59	532 19 47-48	Washer Thrust Sector Steering
60	873 97 10-00	Nut Flange Lock 5/8-11
61	532 19 47-40	Draglink, LH
62	532 19 47-41	Draglink, RH
63	817 00 05-12	Screw 5/16-18 x 3/4
64	532 19 98-49	Retainer Clip Spring Steering
66	871 02 07-48	Bolt Hex Fghd. 7/16-14 x 3 Serr.
67	532 19 47-37	Bushing PM Front Axle
68	873 90 07-00	Nut Lock Flange 7/16-14 Gr. 5
69	532 19 91-62	Washer 1.5 x .505 x .118
70	532 19 61-97	Bracket Deck Susp. Front
71	532 19 07-52	Shaft Extension Steering
72	532 42 89-82	Bolt Fin Hx 5/16-18 x 4 w/Patch
75	580 68 37-01	Pinion
76	580 68 36-01	Screw Head Sock
122	532 44 49-62	Cap Gear

NOTE: All component dimensions given in U.S. inches
1 inch = 25.4 mm

TRACTOR - - MODEL NO. CT 154 (96051010400), PRODUCT NO. 960 51 01 04
 MOWER DECK **44**

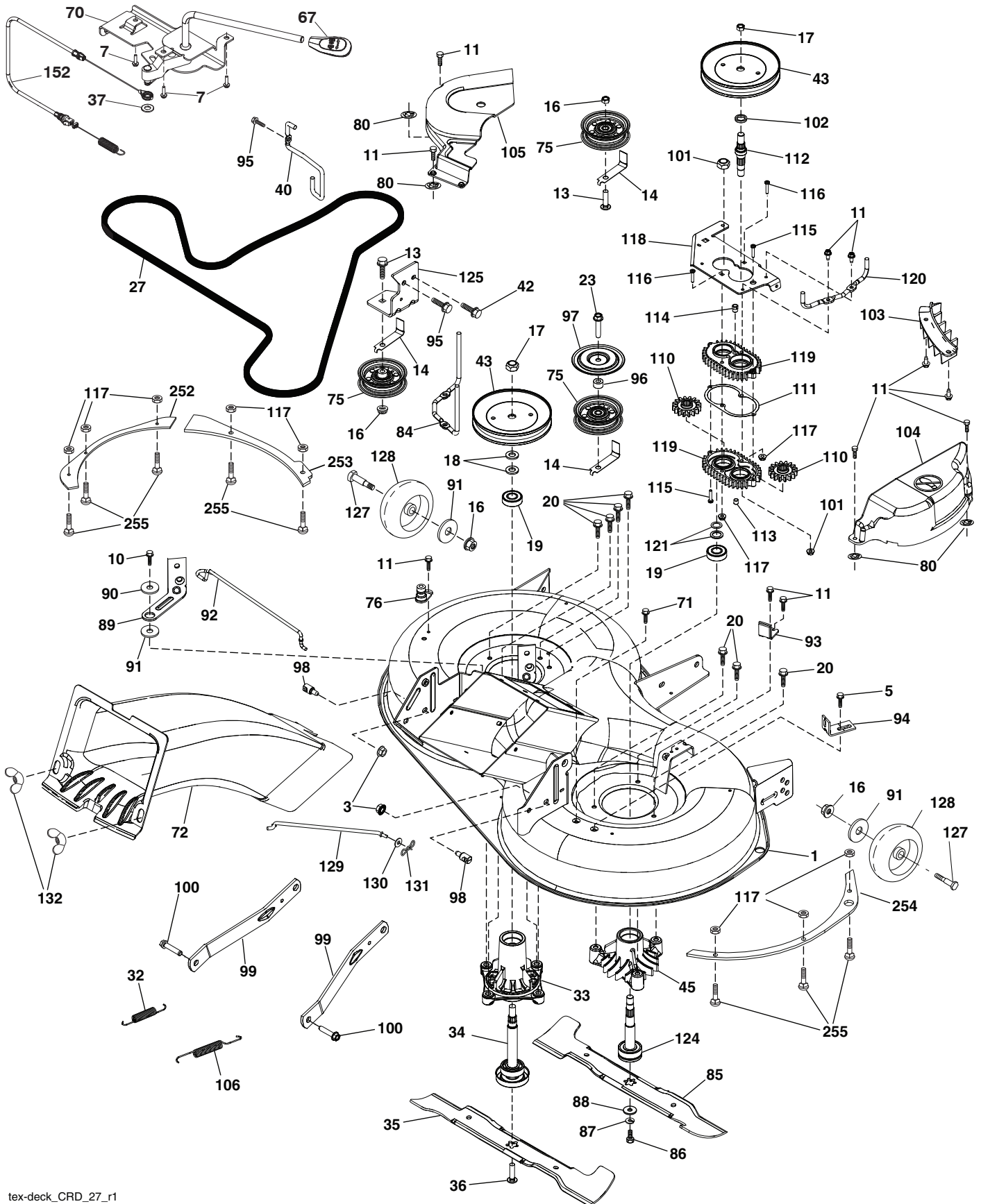

tex-deck_CRD_27_r1

TRACTOR - - MODEL NO. CT 154 (96051010400), PRODUCT NO. 960 51 01 04
MOWER DECK **44**

KEY NO.	PART NO.	DESCRIPTION	KEY NO.	PART NO.	DESCRIPTION
1	532 4409-71	Deck Weldment	97	532 18 20-61	Shield Idler Mower
3	873 90 05-00	Nut Lock Hex Flange 5/16 - 18	98	532 19 51-61	Stud Fastener
5	817 00 05-10	Bolt 5/16-18	99	532 19 51-86	Arm Suspension Mower Rear
7	532 41 63-58	Screw #10 x 0.750 BOS Thread	100	532 19 65-39	Bolt Shoulder
10	817 00 06-16	Screw 3/8-16x1 smgml tap	101	873 68 09-00	Nut Crownlock 9/16 - 18 unc
11	532 13 77-29	Screw Thd Roll 1/4 - 20 X 5/8	102	532 40 25-11	Spacer Bearing Swing Plate
13	872 11 06-12	Bolt Carr Sh 3/8 - 16 X 1 - 1/2 Gr. 5	103	532 43 69-92	Guard Front Vent
14	532 15 60-85	Keeper Belt Idler	104	532 43 89-68	Mandrel Cover RH
16	873 90 06-00	Nut Lock FIG 3/8 - 16 unc	105	532 43 87-44	Mandrel Cover LH
17	532 40 02-34	Nut Flange Lock Top	106	532 19 32-16	Spring Brake Return
18	532 18 76-90	Washer Spacer Mandrel	110	587 93 48-01	Gear Output
19	532 11 04-85	Bearing Ball Mandrel	111	532 43 69-79	Gasket Gearcase
20	532 17 39-84	Screw Thread Roll	112	532 44 38-52	Shaft Gearcase
23	817 49 06-28	Screw Thdrol 3/8 - 16 X 1-3/4	113	532 43 85-33	Plug Oil
27	532 43 97-26	V-Belt Drive	114	532 43 85-34	Valve Relief
32	532 40 18-72	Spring Return Deck	115	818 03 10-16	Screw Torx #10-24 x 1
33	532 18 72-81	Housing Mandrel 4pt Service	116	872 11 04-14	Bolt 1/4-20 x 1.75 Gr. 5
34	532 19 28-72	Shaft Asm Mndrl N/Greaseable38	117	873 90 04-00	Nut Hex Flange 1/4-20 unc
35	532 42 79-84	Blade Mower LH	118	532 43 69-89	Arm Clutching
36	532 19 30-03	Bolt/Washer Asm 7/16 - 20 unf	119	532 43 81-66	Gearcase Subasm
37	819 13 13-16	Washer 13/32 x 13/16 x 16 Ga.	120	532 43 69-91	Keeper Belt RH
40	532 19 72-58	Keeper Belt Engine LH	121	532 43 69-85	Washer
42	817 00 05-12	Screw 5/16-18 x 3/4	124	532 43 69-86	Non Greasable Mandrel Shaft
43	532 19 74-73	Pulley Mandrel	125	532 43 69-94	Bracket Idler Chasses
45	532 13 71-52	Housing Mandrel	127	532 19 34-06	Bolt Shoulder 3/8-16 x 3-5/8 Gr. 5
67	532 40 30-12	Handle Clutch Cable	128	532 17 48-73	Wheel Guage
70	532 40 12-46	Clutch Asm Manual LT Pred	129	532 40 48-51	Rod Anti-Sway
71	817 67 06-08	Screw Thdrol 3/8-16 x 1/2	130	819 13 13-12	Washer 13/32 x 13/16 x 12 Ga.
72	532 44 68-10	Chute Upper	131	532 19 42-08	Pin Cotter 5/16 Bow Tie Lock
75	532 13 14-94	Pulley Idler Flat	132	532 17 88-99	Knob Handle
76	532 41 55-98	Washout Port	152	532 44 04-88	Cable Clutch Manual w/Spring
80	532 42 30-62	Palnut 1/4	252	585 30 88-05	Plate Left
84	532 43 25-20	Keeper Belt LH Mandrel	253	585 30 90-05	Palte LHS
85	532 42 79-85	Blade Mower RH	254	585 30 87-05	Plate RHS
86	532 18 17-13	Bolt 3/8-24 x 1.50 Gr. 8	255	539 10 98-00	Carraige Bolt
87	810 03 06-00	Washer Lock Hvy 3/8	--	532 19 28-70	Mandrel Assembly (Includes Housing (key #14), Shaft Assembly (key #13), And Bearing (key #15)Only - Pulley/Nut/Washer And Blade Bolt/Washers Not Included)
88	532 14 02-96	Washer Hard Blade Mower Vented			
89	532 43 81-24	Arm Brake 97 LH			
90	532 19 90-92	Spacer Retainer			
91	819 13 20-12	Washer 13/32 x 1-1/4 x 12 Ga.			
92	532 43 69-93	Rod Brake			
93	532 43 81-25	Arm Brake RH	--	532 44 84-86	Replacement Mower Complete
94	532 19 72-50	Bracket Clutch Cable			
95	817 00 06-12	Screw 3/8-16 x 3/4			
96	532 40 02-71	Spacer			

NOTE: All component dimensions given in U.S. inches
1 inch = 25.4 mm

TRACTOR - - MODEL NO. CT 154 (96051010400), PRODUCT NO. 960 51 01 04
MOWER LIFT **45**

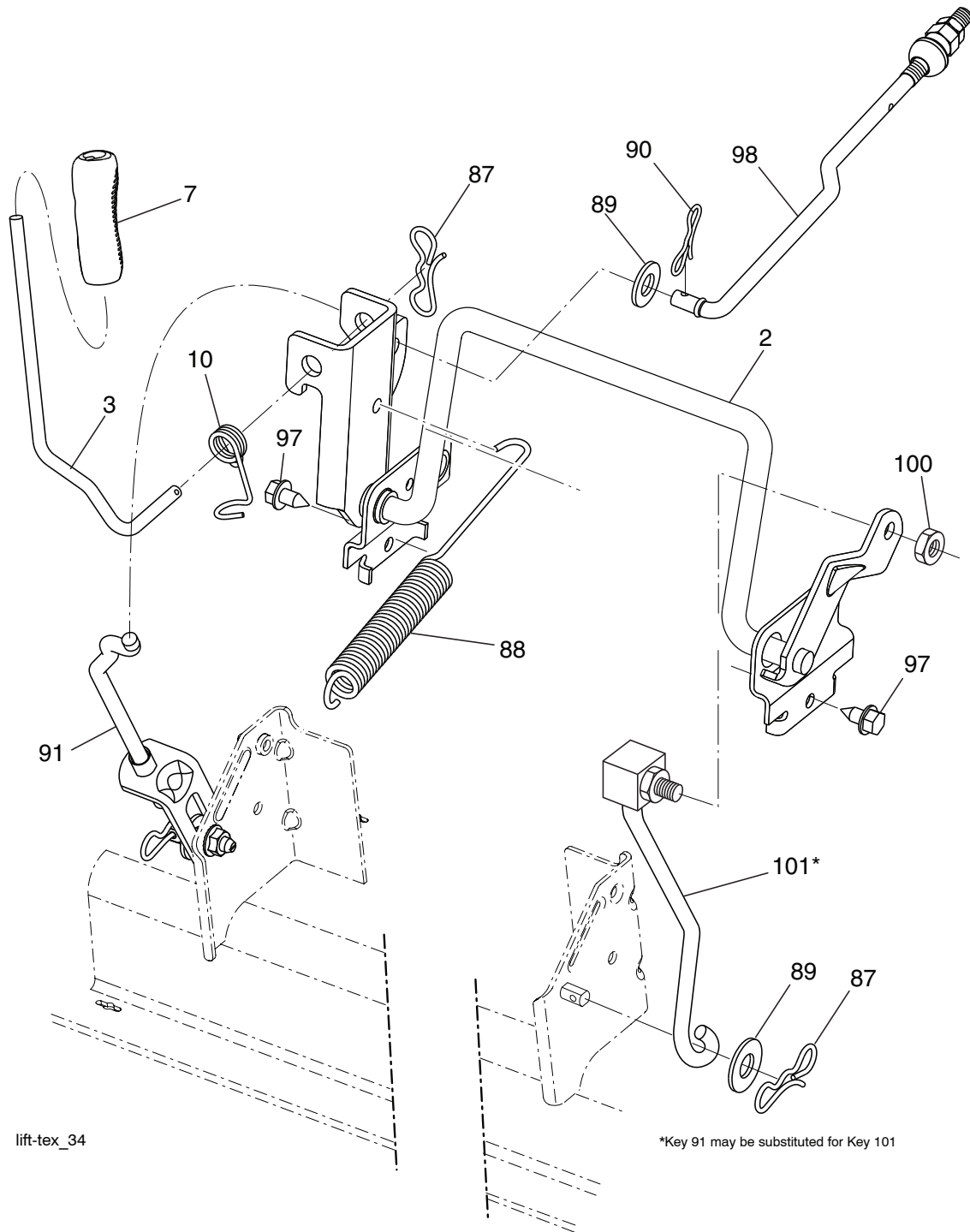

KEY NO.	PART NO.	DESCRIPTION
2	532 43 69-96	Deck Lift Weldment
3	532 19 52-31	Lever Asm., Lift RH
7	532 41 15-55	Grip, Lever
10	532 19 63-14	Spring Torsion
87	532 19 42-09	Pin Cotter 7/16 Bow Tie Lock
88	532 43 69-95	Spring Lift Assist
89	819 19 19-12	Washer Clear Zinc
90	532 19 42-08	Pin Cotter 5/16 Bow Tie Lock

KEY NO.	PART NO.	DESCRIPTION
91	532 19 51-81	Link Lift Susp. Mower Rear
97	817 49 06-08	Screw 3/8-16 x 1/2
98	532 19 52-70	Link Lift Susp. Front Mower
100	873 93 06-00	Nut Centerlock 3/8-16
101	532 40-70-03	Link Asm. Lift FXD

NOTE: All component dimensions given in U.S. inches
1 inch = 25.4 mm

**TRACTOR - - MODEL NO. CT 154 (96051010400), PRODUCT NO. 960 51 01 04
SEAT ASSEMBLY 42**

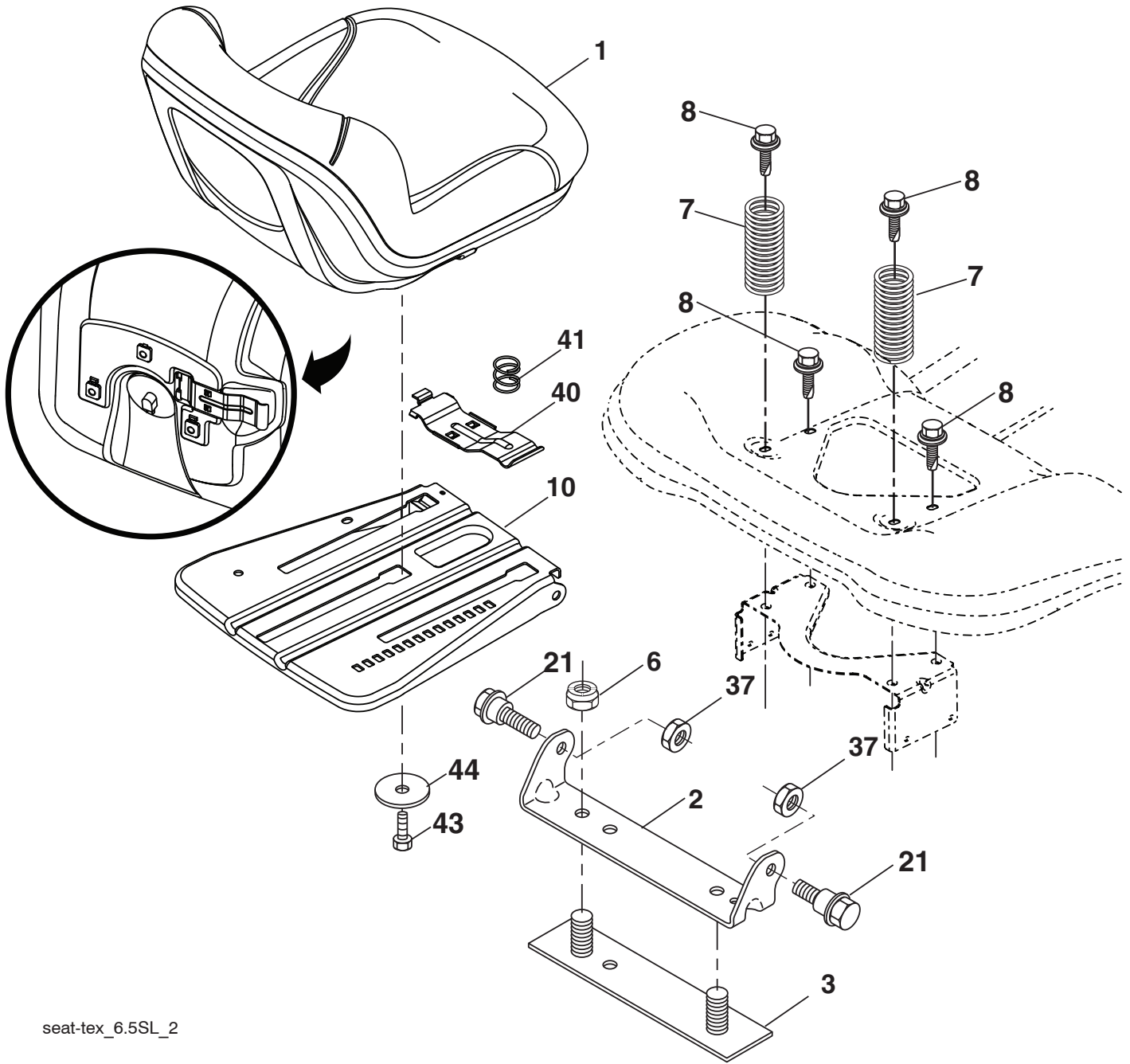

seat-tex_6.5SL_2

KEY NO.	PART NO.	DESCRIPTION
1	532 43 98-19	Seat
2	532 18 01-66	Bracket Pivot Fender
3	532 14 06-75	Strap, Asm. Fender
6	873 80 06-00	Nut, Lock w/Ins. 3/8-16 unc
7	532 12 41-81	Spring, Seat Cprsn.
8	532 17 18-77	Bolt 5/16-18 unc x 3/4 w/Sems.
10	532 19 69-77	Pan, Seat
21	532 17 18-52	Bolt, Shoulder 5/16-18

KEY NO.	PART NO.	DESCRIPTION
37	873 80 05-00	Nut, Lock 5/16-18 unc
40	532 19 76-61	Handle
41	532 19 82-00	Spring
43	874 76 06-12	Bolt 3/8-16 unc x 3/4
44	819 13 38-12	Washer 13/32 x 2-3/8 x 12 Ga.

NOTE: All component dimensions given in U.S. inches
1 inch = 25.4 mm

TRACTOR - - MODEL NO. CT 154 (96051010400), PRODUCT NO. 960 51 01 04
BAGGER **46**

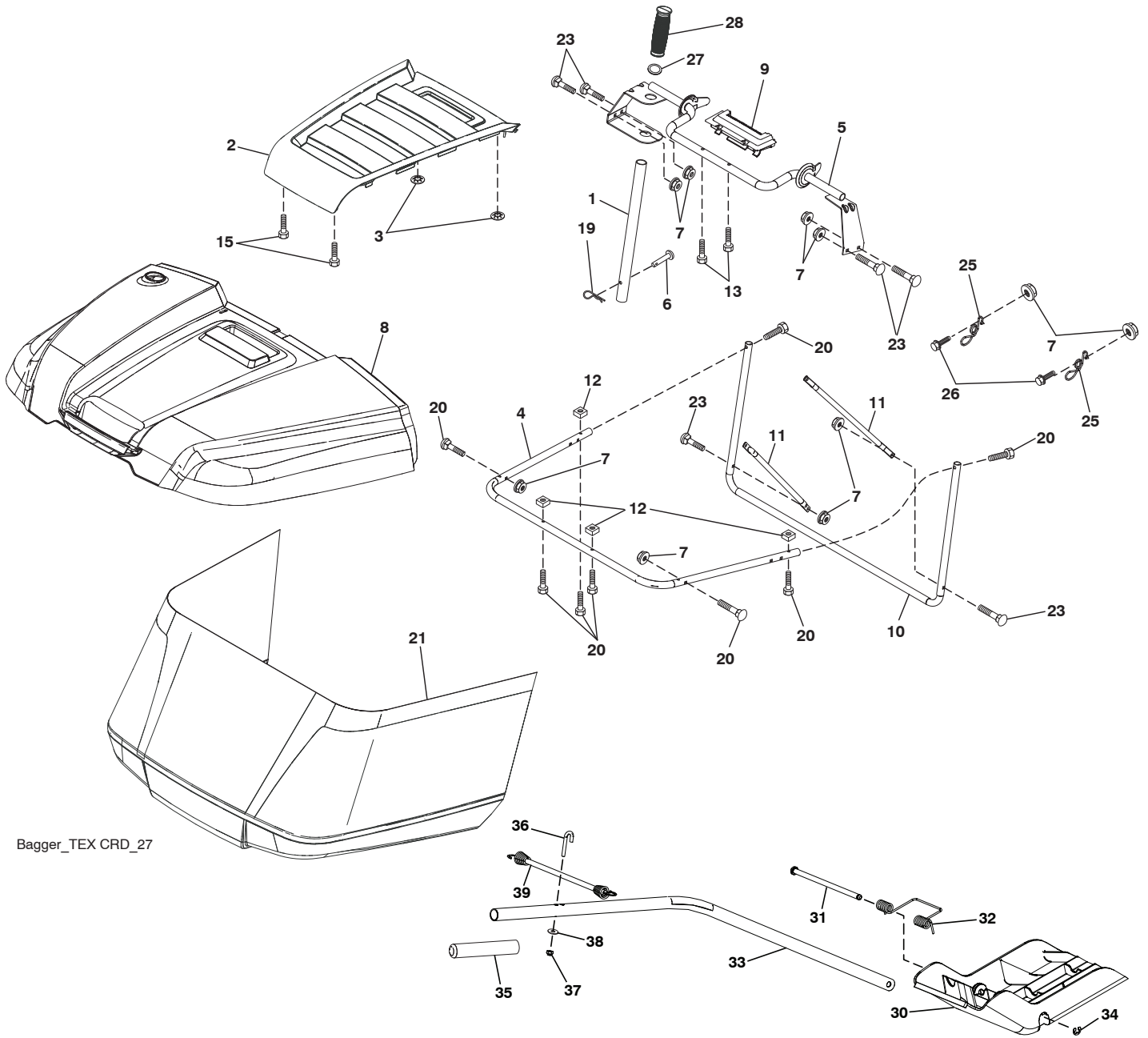

Bagger_TEX CRD_27

**TRACTOR - - MODEL NO. CT 154 (96051010400), PRODUCT NO. 960 51 01 04
BAGGER 46**

KEY NO.	PART NO.	DESCRIPTION
1	532 42 86-10	Tube Handle Bagger
2	532 44 13-58	SRD Bagger Applique
3	532 41 38-08	Nut Push
4	532 43 96-12	Frame Asm Bagger Top
5	532 41 76-32	Frame Asm Top Bagger
6	532 12 68-75	Rivet Drilled
7	873 90 04-00	Nut Hex Flange 1/4-20 unc
8	532 44 12-61	Cover Bagger
9	532 41 76-29	Insert Handle Bagger
10	532 43 67-70	Frame Front
11	532 43 67-71	Tubing Brace Bagger
12	532 42 17-93	Nut Square 1/4
13	532 42 17-80	Screw 1/4 x 1.150
15	532 42 18-01	Screw #8 Flat Head Drill Tip
19	532 19 42-08	Cotter Pin 5/16 Bow Tie
20	585 36 88-01	Screw Hex Cap 1/4-20 x 1.375
21	532 44 83-06	Bag Asm
23	872 04 04-10	Bolt Carr. 1/4-20
25	532 42 16-14	Spring Latch Bagger
26	817 49 04-12	Screw Hexwsh Thdrol 1/4-20 x 3/4
27	532 42 12-62	Grommet Rubber
28	532 16 57-87	Grip Handle Black
30	532 43 74-52	Plug
31	532 43 58-61	Pin Hinge
32	532 43 74-54	Spring Double Torsion
33	532 43 84-51	Shaft Mulch Plug
34	532 43 79-88	E-Ring 5/16
35	532 43 91-39	Grip Mulch Plug
36	532 43 90-98	Bolt J
37	532 06 91-80	Nut Lock #10-24 unc
38	819 07 08-18	Washer 7/32 x 1/2
39	532 43 92-42	Bungee

NOTE: All component dimensions given in U.S. inches
1 inch = 25.4 mm

