

ILLUSTRATED PARTS LIST

MFG. ID NO. 96041033200

CUSTOMER CATALOG NO. YTH 224T

PRODUCT NO. 960 41 03-32

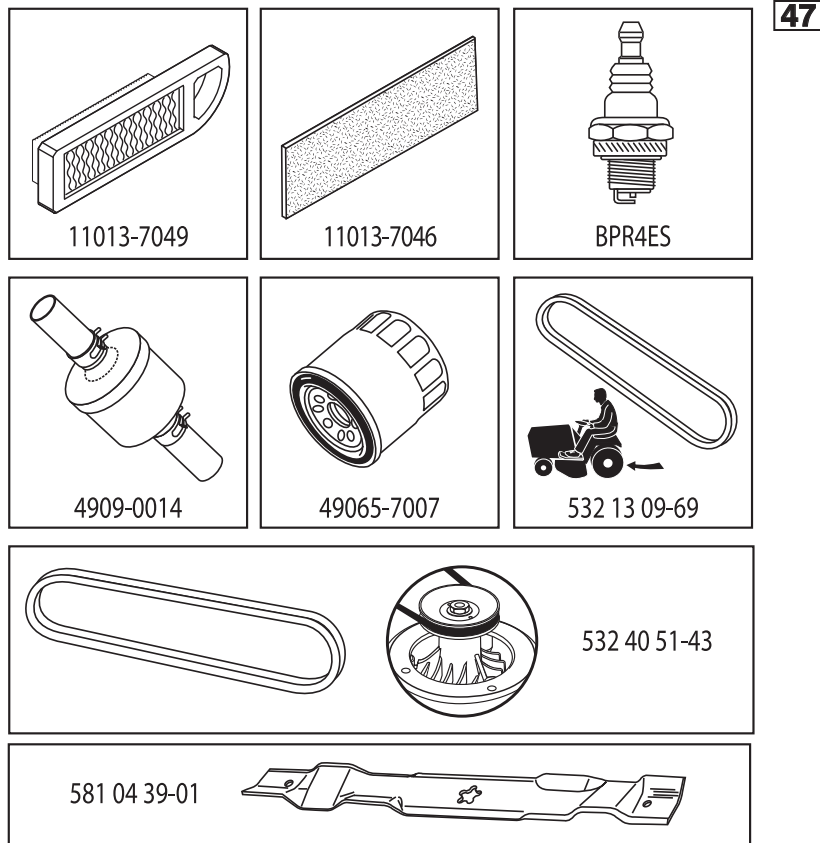

586300101

**TRACTOR - MODEL NO. YTH 224T (96041033200), PRODUCT NO. 960 41 03-32
DECALS 27**

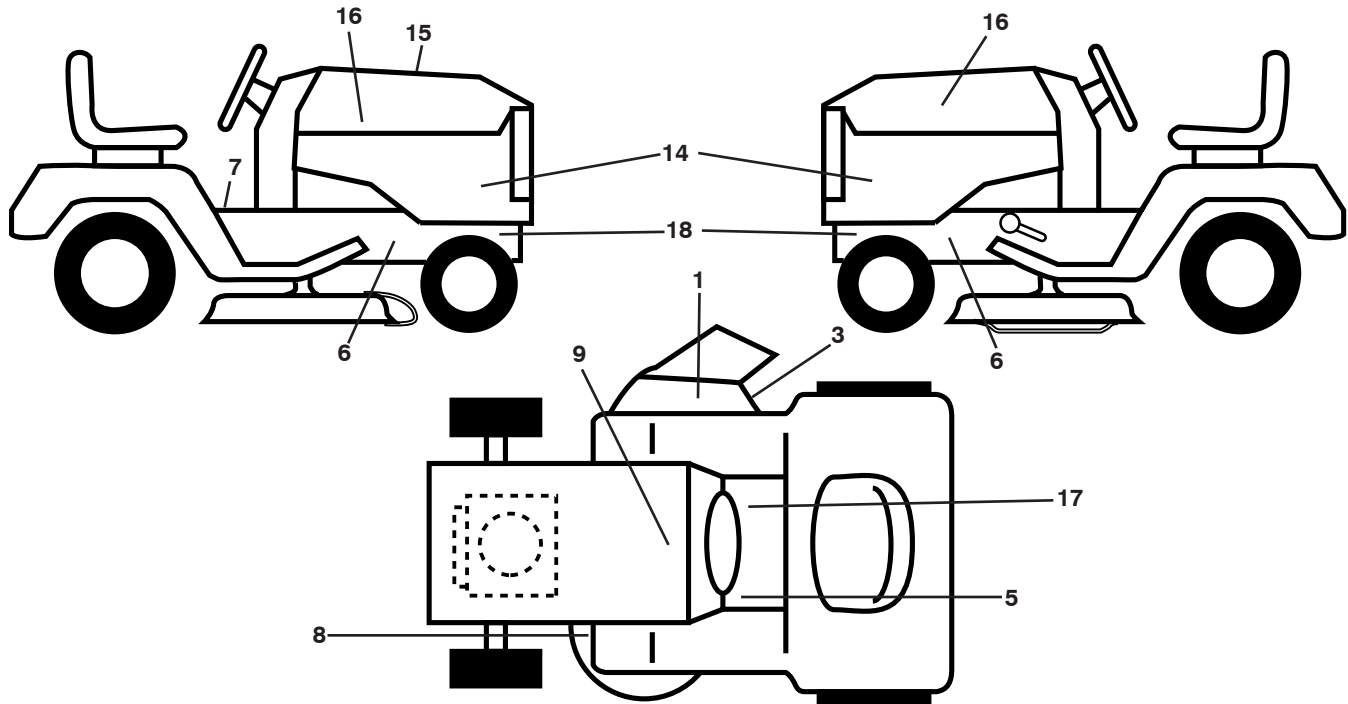

KEY NO.	PART NO.	DESCRIPTION
1	584 90 46-01	Decal, Deflect. Warning
3	581 57 92-01	Decal, Warning
5	581 72 40-01	Decal, Brake Pedal
6	581 57 98-01	Decal, Warning
7	581 57 81-01	Decal, Warning Symbols
8	581 58 00-01	Decal, Mower Sch.
9	532 14 50-05	Decal, Battery Dan./Poi.
14	532 44 63-77	Decal, Panel Side
15	586 30 01-01	Decal, Replacement Parts

KEY NO.	PART NO.	DESCRIPTION
16	581 62 73-01	Decal, Hood Logo
17	581 57 80-01	Decal, Park Brake
18	581 57 96-01	Decal, Chassis Hot Muffler
--	581 72 46-01	Decal, Drawbar Load Limit
--	581 72 48-01	Decal, Bypass
--	532 43 98-82	Pad, Footrest, LH
--	532 43 98-81	Pad, Footrest, RH
--	586 20 53-40	Manual, Operator's (Euro)

WHEELS AND TIRES

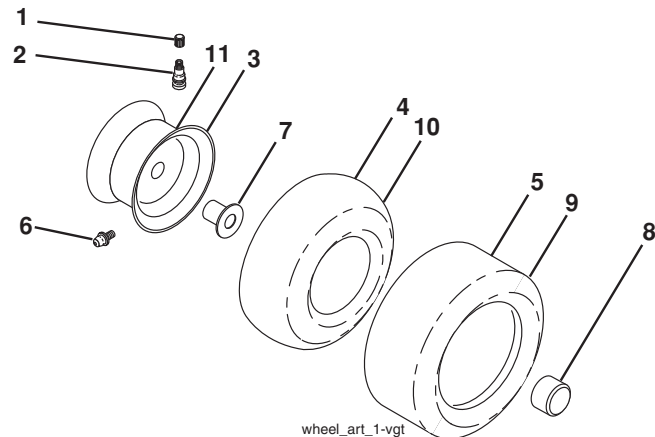

KEY NO.	PART NO.	DESCRIPTION
1	532 05 91-92	Cap, Valve, Tire
2	532 06 51-39	Stem, Valve
3	532 13 83-36	Rim Assembly, Front
4	532 05 99-04	Tube, Front (Service Item Only)
5	532 10 62-22	Tire, Front 15 X 6-6
6	532 12 49-57	Fitting, Grease (Front Wheel Only)
7	532 12 49-59	Bearing, Flange (Front Wheel Only)
8	532 17 50-39	Cap, Axle (Front Wheel Only)
9	532 12 20-82	Tire, Rear 20 X 10-8
10	532 12 49-26	Tube, Rear (Service Item Only)
11	532 13 83-37	Rim Assembly, Rear
--	532 14 43-34	Sealant, Tire (10 oz. Tube)

NOTE: All component dimensions given in U.S. inches
1 inch = 25.4 mm

TRACTOR - MODEL NO. YTH 224T (96041033200), PRODUCT NO. 960 41 03-32

SCHEMATIC 38

SCH13

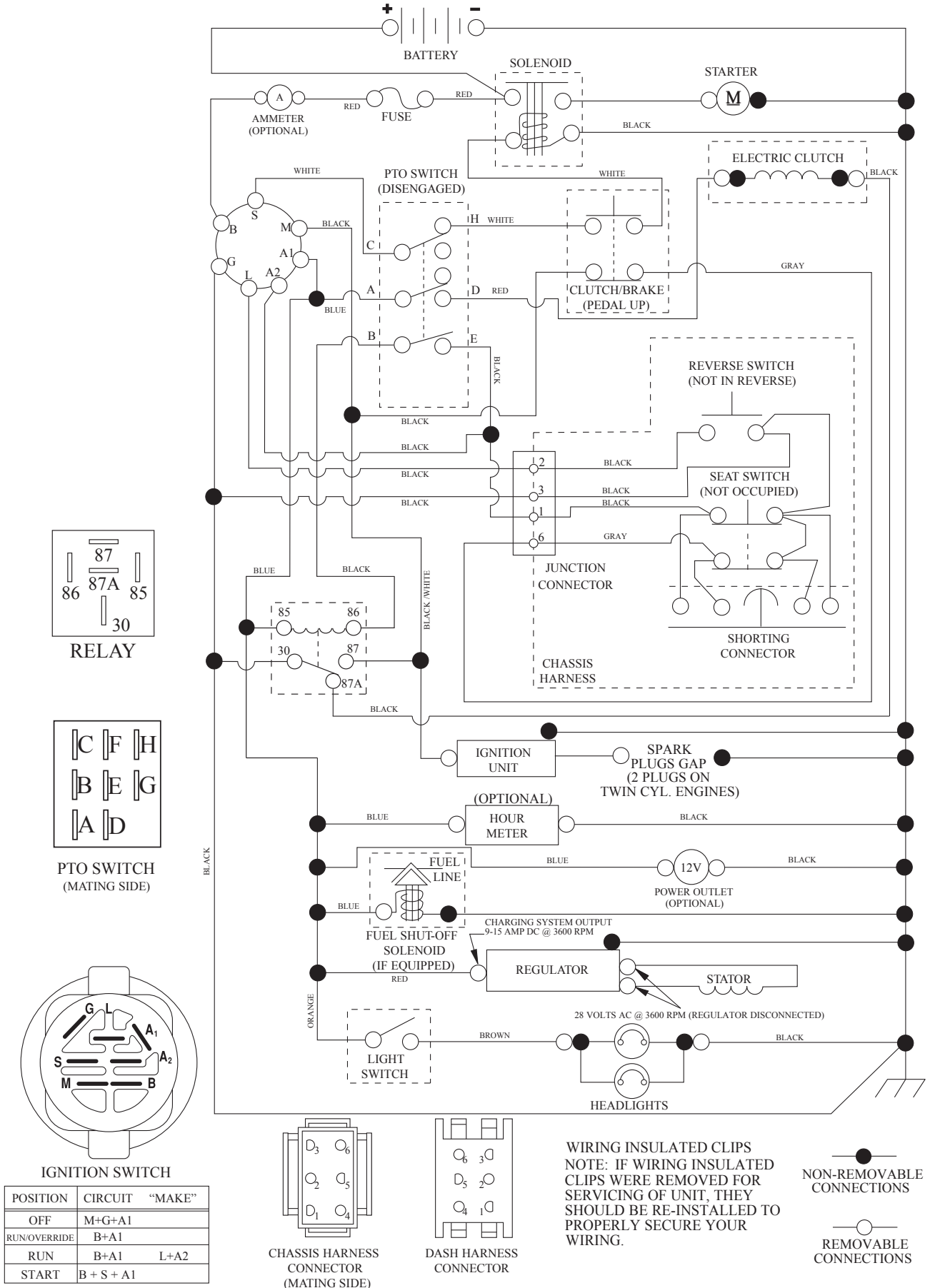

POSITION	CIRCUIT	"MAKE"
OFF	M+G+A1	
RUN/OVERRIDE	B+A1	
RUN	B+A1	L+A2
START	B + S + A1	

TRACTOR - MODEL NO. YTH 224T (96041033200), PRODUCT NO. 960 41 03-32
ELECTRICAL 32

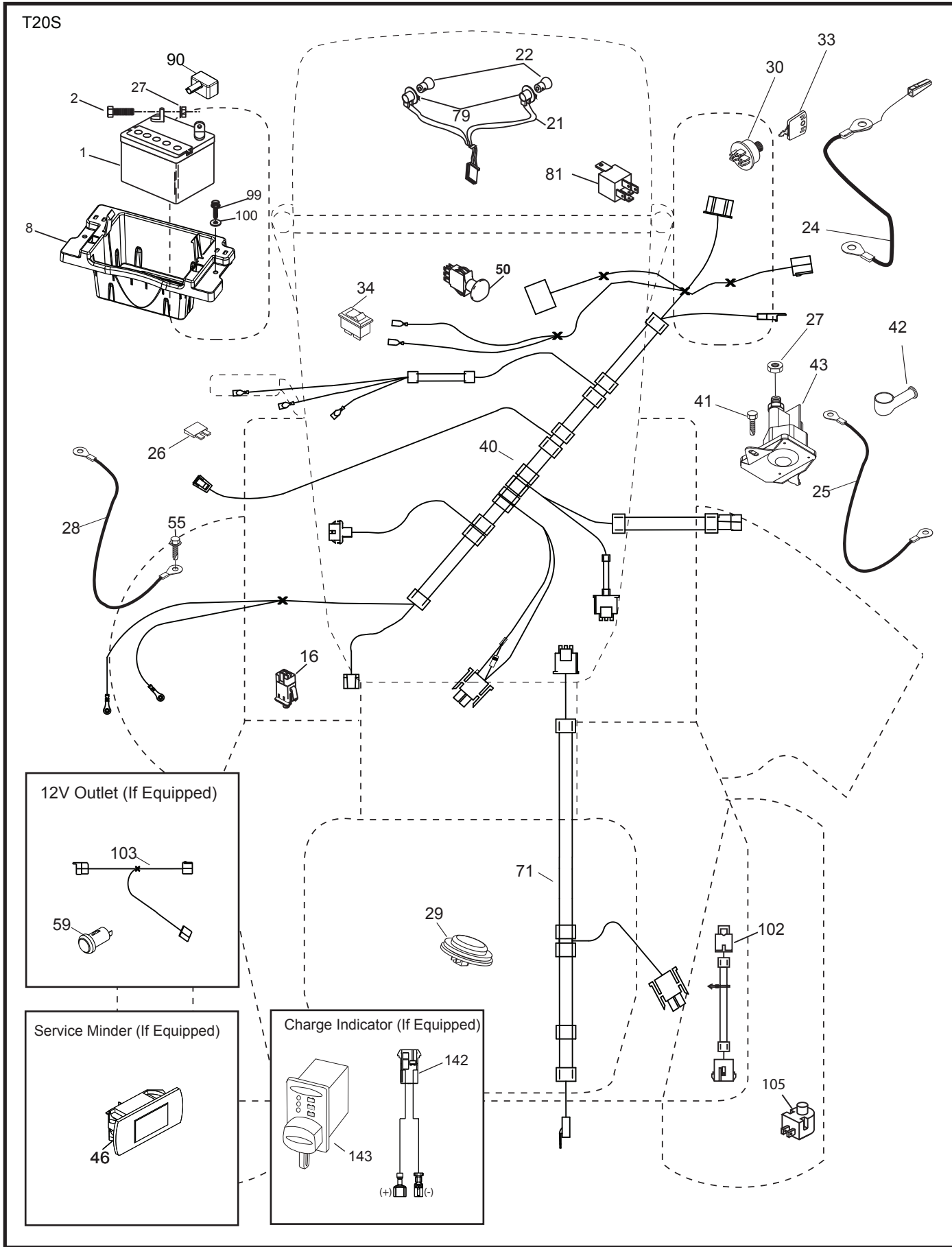

**TRACTOR - MODEL NO. YTH 224T (96041033200), PRODUCT NO. 960 41 03-32
ELECTRICAL 32**

KEY NO.	PART NO.	DESCRIPTION
1	532 16 34-65	Battery
2	874 76 04-12	Bolt Hex Hd. 1/4-20 unc x 3/4
8	587 20 51-01	Battery Box
16	532 17 61-38	Switch Interlock
21	532 40 02-52	Harness Light w/4152J
22	532 00 41-52	Bulb, Light # 1156
24	585 55 56-01	Cable Battery
25	532 41 28-95	Cable Starter
26	532 17 51-58	Fuse
27	873 51 04 00	Nut Keps Hex 1/4-20 unc
28	532 41 65-88	Cable Ground
29	532 40 15-45	Switch Seat
30	532 19 33-50	Switch Ign.
33	532 41 19-35	Key/Chain
34	532 11 07-12	Switch Light/Reset
40	581 02 28-01	Harness Ign. Dash
41	817 72 04-08	Screw 1/4-20 x 1/2
42	532 13 15-63	Cover Terminal
43	532 19 25-07	Solenoid
46	532 40 17-63	Gauge Hourmeter
50	532 17 46-51	Switch PTO
55	817 06 05-12	Screw 5/16-18 x 3/4
71	532 19 42-76	Harness Ign. Chassis/Light
79	532 17 52-42	Socket Asm. Bulb
81	532 40 96-15	Relay Harness
90	532 43 53-95	Cover Terminal Battery
99	817 67 04-12	Screw Hex Wsh. Thdrol. 1/4-20 x 3/4
100	819 09 14-16	Washer 9/32 x 7/8 x 16 Ga.
102	532 40 44-54	Harness Pigtail Tex ROS Tufftorq
105	532 40 75-68	Switch Reverse
142	583 85 78-01	Charge Port Pigtail
143	532 44 80-59	Charge Port

NOTE: All component dimensions given in U.S. inches
1 inch = 25.4 mm

TRACTOR - MODEL NO. YTH 224T (96041033200), PRODUCT NO. 960 41 03-32
CHASSIS AND ENCLOSURES **39**

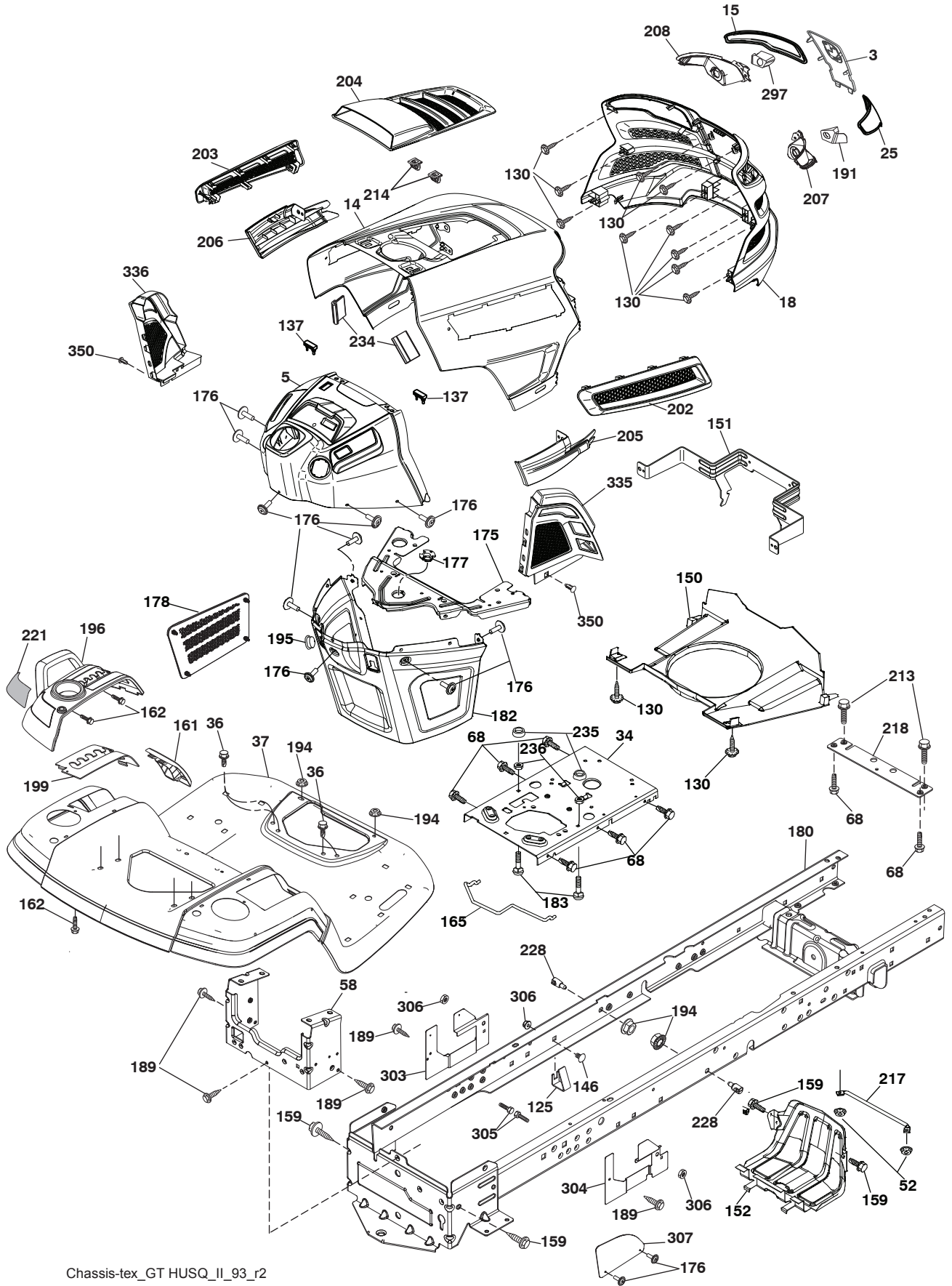

Chassis-tex_GT HUSQ_II_93_r2

**TRACTOR - MODEL NO. YTH 224T (96041033200), PRODUCT NO. 960 41 03-32
CHASSIS AND ENCLOSURES 39**

KEY NO.	PART NO.	DESCRIPTION	KEY NO.	PART NO.	DESCRIPTION
3	532 43 97-52	Applique Sub Asm.	195	532 40 41-37	Plug 12 V Adapter
5	532 43 74-84	Dash	196	532 43 97-16	Console Asm. Deck Lift
14	532 44 11-77	Hood	199	532 19 82-59	Plate Deck Lift
15	532 43 97-33	Lens LH	202	532 43 97-28	Vent Side Hood RH
18	532 44 06-53	Grille	203	532 43 97-27	Vent Side Hood LH
25	532 44 33-85	Lens RH	204	532 43 57-14	Vent Asm. Hood Top
34	580 91 08-01	Plate Engine	205	532 43 97-30	Trim Hood Side RH
36	817 06 05-12	Screw 5/16-18 x 3/4	206	532 43 97-29	Trim Hood Side LH
37	532 44 12-08	Fender	207	532 43 97-34	Bezel RH
52	873 68 05-00	Nut Crownlock 5/16-18	208	532 43 97-35	Bezel LH
58	532 41 22-81	Drawbar Upper	213	874 76 05-12	Bolt Hex Hd. 5/16-18 unc x 3/4
68	817 49 05-08	Screw 5/16-18 x 1/2	214	532 19 91-45	Clip Retainer
125	581 68 48-01	Clip Fuel Line	217	532 40 91-67	Rod Pivot
130	532 41 63-58	Screw #10 x 0.750	218	532 19 63-95	Hood Stop
137	532 40 75 90	Bumper Dash	221	532 19 89-09	Reflector LH
146	581 85 79-01	Bolt	228	532 19 51-61	Stud Fastener
150	532 43 97-74	Duct Heat Hood	234	532 40 47 42	Bumper Hood
151	532 43 66-70	Pivot Bracket	235	532 40 61 29	Spacer Fender
152	532 43 98-70	Shield Browning/Debris	236	873 93 05-00	Nut 5/16-18 unc
159	817 00 06-12	Screw 3/8-16 x 3/4 BL	297	532 43 74 56	Insert Reflective LH
161	532 43 99-29	Console Fuel Window	303	532 42 09-59	Shield Chassis Fren LH
162	532 14 24-32	Screw Hex Wsh. Hi-Lo 1/4 x 1/2	304	532 42 15-09	Shield Chassis Fren RH
165	532 19 68-26	Bracket Support Tank	305	872 11 06-06	Bolt 3/8-16 x 3/4
175	532 19 63-04	Crossmember	306	873 90 06-00	Nut 3/8-16 unc
176	532 40 07-76	Screw #10-24 x 5/8	307	532 42 45-70	Shield Upper Pedal
177	532 19 52-28	Bushing Steering	335	532 44 82-04	Lower Dash Cover RH
178	532 19 97-82	Cargo Asm. Net	336	532 44 53-09	Lower Dash Cover LH
180	532 41 50-64	Chassis	350	532 44 51-43	Clip X-mas Tree
182	532 40 68-59	Dash Lower	- -	532 43 18-82	Kit Guard Brush
183	874 52 05-20	Bolt 5/16-18 unc x 1-1/4			
189	817 00 05-12	Screw 5/16-18 x 3/4			
191	532 43 74-55	Insert Reflective RH			
194	873 90 05-00	Nut Lock Hex Flange 5/16-18			

NOTE: All component dimensions given in U.S. inches
1 inch = 25.4 mm

TRACTOR - MODEL NO. YTH 224T (96041033200), PRODUCT NO. 960 41 03-32
DRIVE 40

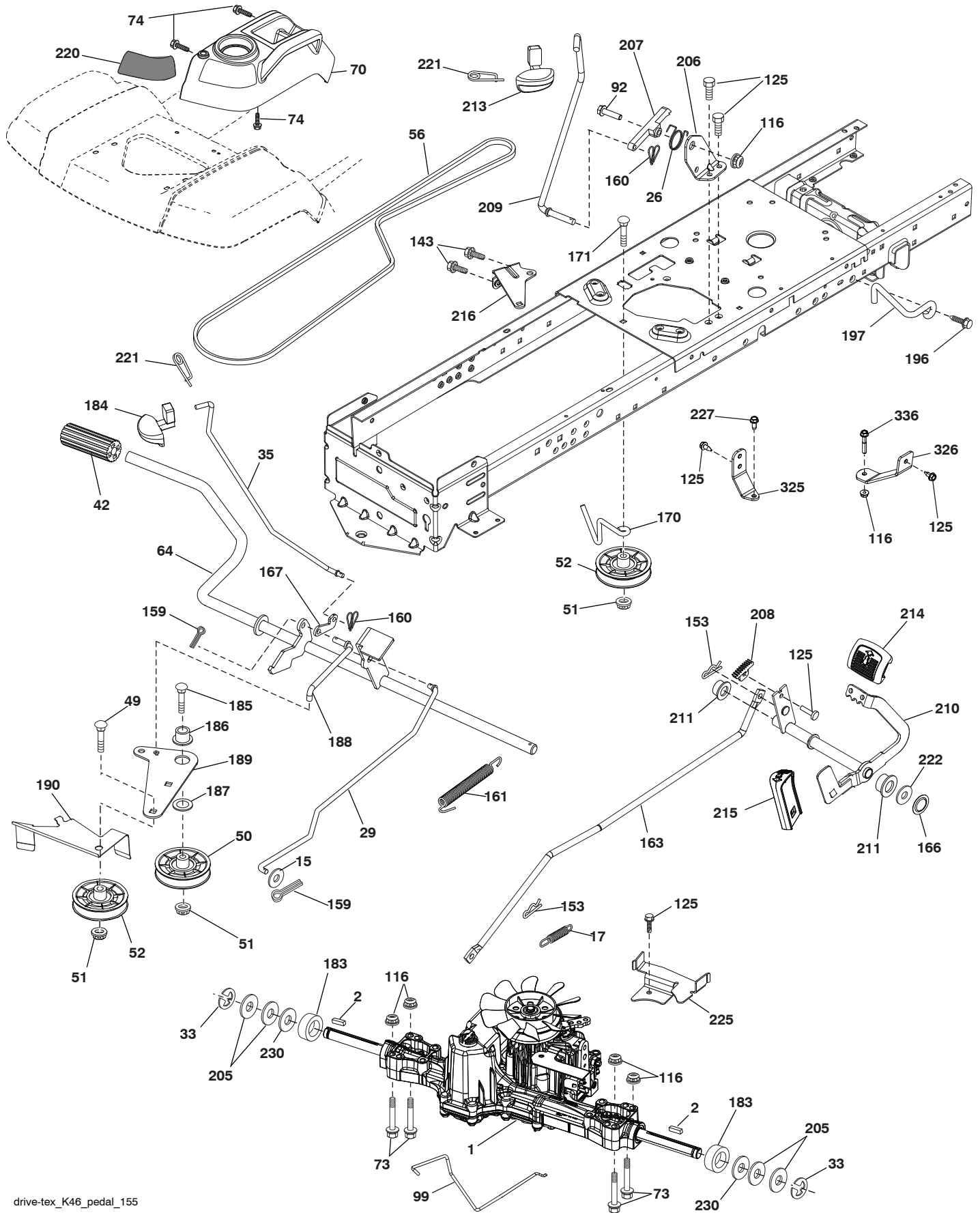

**TRACTOR - MODEL NO. YTH 224T (96041033200), PRODUCT NO. 960 41 03-32
DRIVE 40**

KEY NO.	PART NO.	DESCRIPTION	KEY NO.	PART NO.	DESCRIPTION
1	-----	Transaxle, TuffTorq K46BT (426120) (Order parts from trans- axle manufacturer.)	183	532 13 70-57	Spacer Axle
2	532 12 35-83	Key	184	532 44 14-55	Handle Parking Brake
15	819 13 13-16	Washer 13/32 x 13/16 x 16 Ga.	185	872 11 06-22	Bolt
17	532 41 36-78	Spring, Brake	186	532 19 43-21	Spacer Retainer
26	532 19 96-79	Spring Return Cruise	187	819 13 32-10	Washer
29	532 40 38-06	Rod, Brake	188	532 19 43-23	Link Clutch Ground Drive
33	812 00 00-01	Ring E	189	532 19 43-17	Bellcrank Ground Drive
35	583 86 45-01	Rod, Brake, Park	190	532 19 43-18	Keeper Bellcrank Ground Drive
42	532 12 48-72	Cover, Foot Pedal	196	817 00 06-16	Screw 3/8-16 x 1
49	872 11 06-14	Bolt	197	585 65 86-01	Link Clutch Anti-Rotation
50	532 19 43-27	Pulley Idler Flat	205	532 12 17-48	Washer 25/32 x 1-5/8 x 16 Ga.
51	873 90 06-00	Lock Nut 3/8-16	206	532 44 85-96	Bracket Mount Latch Cruise
52	532 19 43-26	Idler V-Groove	207	532 19 78-68	Latch Control Cruise
56	532 13 09-69	V-Belt, Drive	208	532 19 78-69	Gear Sector Control Cruise
64	532 19 78-65	Shaft Asm. Pedal Brake Control	209	532 19 95-92	Rod Control Cruise
70	532 43 96-61	Console Asm.	210	532 19 78-60	Rocker Asm Cruise
73	874 49 05-40	Bolt 5/16-18 x 1/2 Gr 5	211	532 12 01-83	Bearing Nylon
74	532 14 24-32	Screw Hx Wsh Hi-Lo 1/4 x 1/2 unc	213	532 40 31-19	Handle Parking Brake
92	874 76 05-20	Bolt Fin Hex 5/16-18 unc x 1.25	214	532 42 12-63	Pedal Forward Pad
99	532 41 57-42	Rod Bypass	215	532 40 17-23	Pedal Reverse Pad
116	873 90 05-00	Nut Lock Hex Flange 5/16-18	216	532 19 61-31	Bracket Pulley Idler
125	817 00 05-12	Screw 5/16-18 x 3/4	220	532 19 89-08	Reflector RH
143	817 49 05-08	Screw 5/16-18 x 1/2	221	532 40 31-87	Retainer Spring Clip Handle
153	532 12 47-88	Retainer Spring	222	879 21 20-10	Washer 21/32 x 1-1/4 10 Ga.
159	876 02 04-12	Pin Cotter 1/8 x 3/4	225	532 40 33-19	Keeper Belt Trans.
160	532 16 94-84	Retainer Clip	227	817 49 05-12	Screw Thdrol 5/16-18 x 3/4
161	532 10 57-09	Spring, Return, Clutch	230	532 18 89-67	Washer Hardened
163	532 44 82-75	Rod Pedal Control	325	585 66 85-02	Bracket
166	532 42 91-64	Nut Push .625	326	585 67 08-02	Bracket
167	532 40 52-57	Latch Brake Parking	336	587 25 96-01	Bolt
170	532 19 43-22	Keeper Belt Centerspan			
171	872 11 06-16	Bolt			

NOTE: All component dimensions given in U.S. inches
1 inch = 25.4 mm

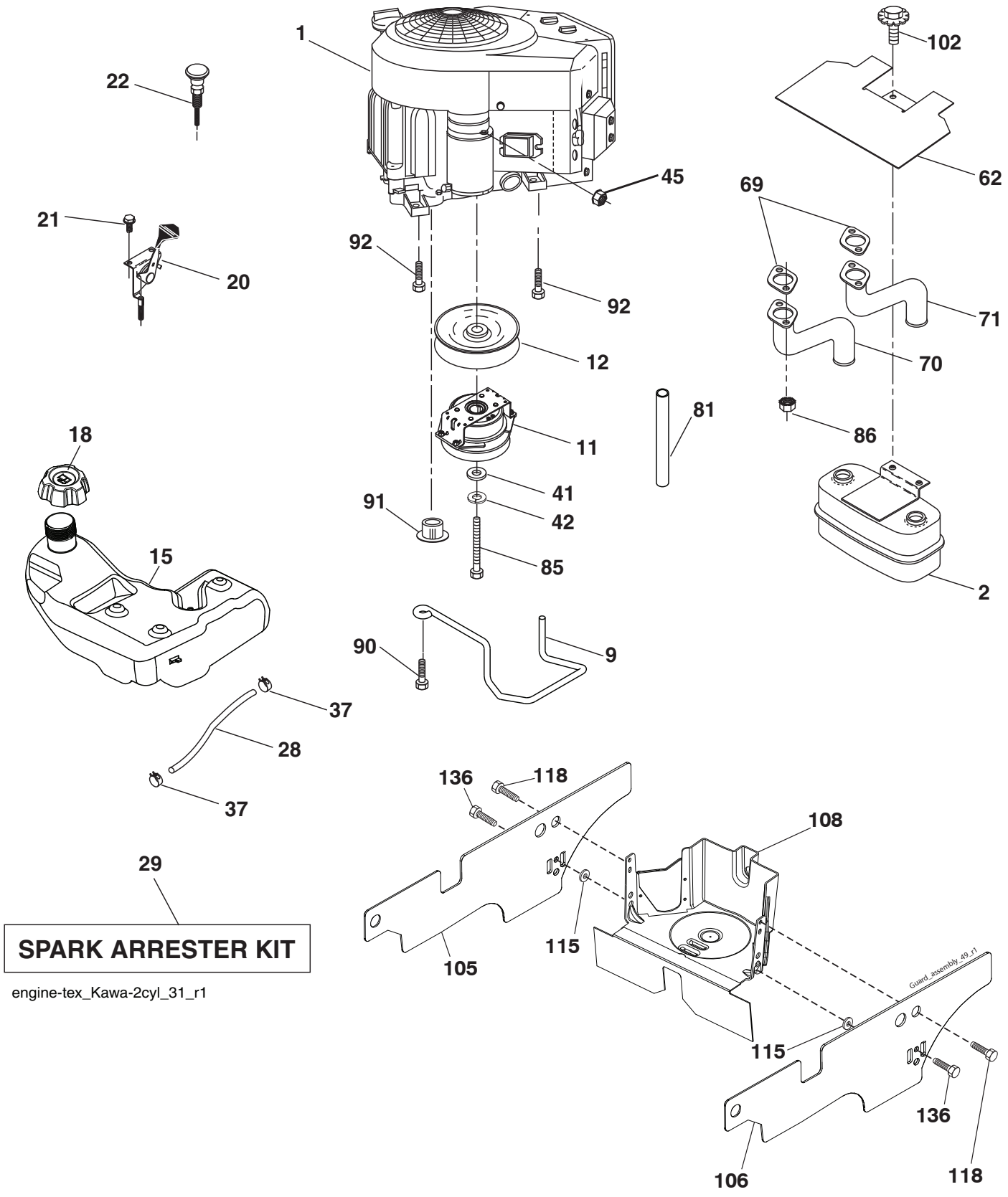

SPARK ARRESTER KIT

engine-tex_Kawa-2cyl_31_r1

**TRACTOR - MODEL NO. YTH 224T (96041033200), PRODUCT NO. 960 41 03-32
ENGINE 24**

KEY NO.	PART NO.	DESCRIPTION
1	---	Kawasaki FS651V-BS50 (445368) (Order parts from engine manufacturer.)
2	532 44 59-62	Muffler
9	584 90 80-01	Keeper Belt Engine
11	587 24 16-01	Clutch Electric
12	532 40 50-97	Pulley Engine
15	532 19 34-99	Tank Fuel 4.0
18	532 43 96-45	Cap Fuel
20	532 41 21-65	Control Throttle
21	532 41 63-58	Screw #10 x 0.750
22	532 18 95-41	Control Choke
28	532 14 21-58	Fuel Line
29	532 13 71-80	Spark Arrester Kit
37	532 12 34-87	Clamp Hose
41	532 12 61-97	Washer 1-1/2 OD x 15/32 ID x .250
42	810 04 07-00	Washer Lock 7/16
45	873 51 04-00	Nut Keps 1/4-20 unc
62	532 43 40-17	Shield Heat Muffler
69	532 17 81-51	Gasket
70	583 95 56-01	Tube Exhaust LH
71	583 95 57-01	Tube Exhaust RH
81	532 14 84-56	Tube Drain Oil Easy
85	532 17 99-53	Bolt 7/16-20 x 3.75 Gr.
86	532 18 43-62	Nut
90	817 00 06-16	Screw 3/8-16 x 1
91	532 18 74-95	Bushing
92	817 12 06-16	Screw 3/8-16 x 1
102	817 00 05-12	Screw 5/16-18 x 3/4
105	532 41 56-06	Shield Side LH
106	532 41 56-11	Shield Side RH
108	532 42 68-03	Cover Asm. Engine
115	532 42 30-62	Palnut 1/4
118	817 67 05-08	Screw 5/16-18 x 1/2
136	532 13 77-29	Screw 1/4-20 x 5/8

NOTE: All component dimensions given in U.S. inches
1 inch = 25.4 mm

TRACTOR - MODEL NO. YTH 224T (96041033200), PRODUCT NO. 960 41 03-32
STEERING ASSEMBLY [41]

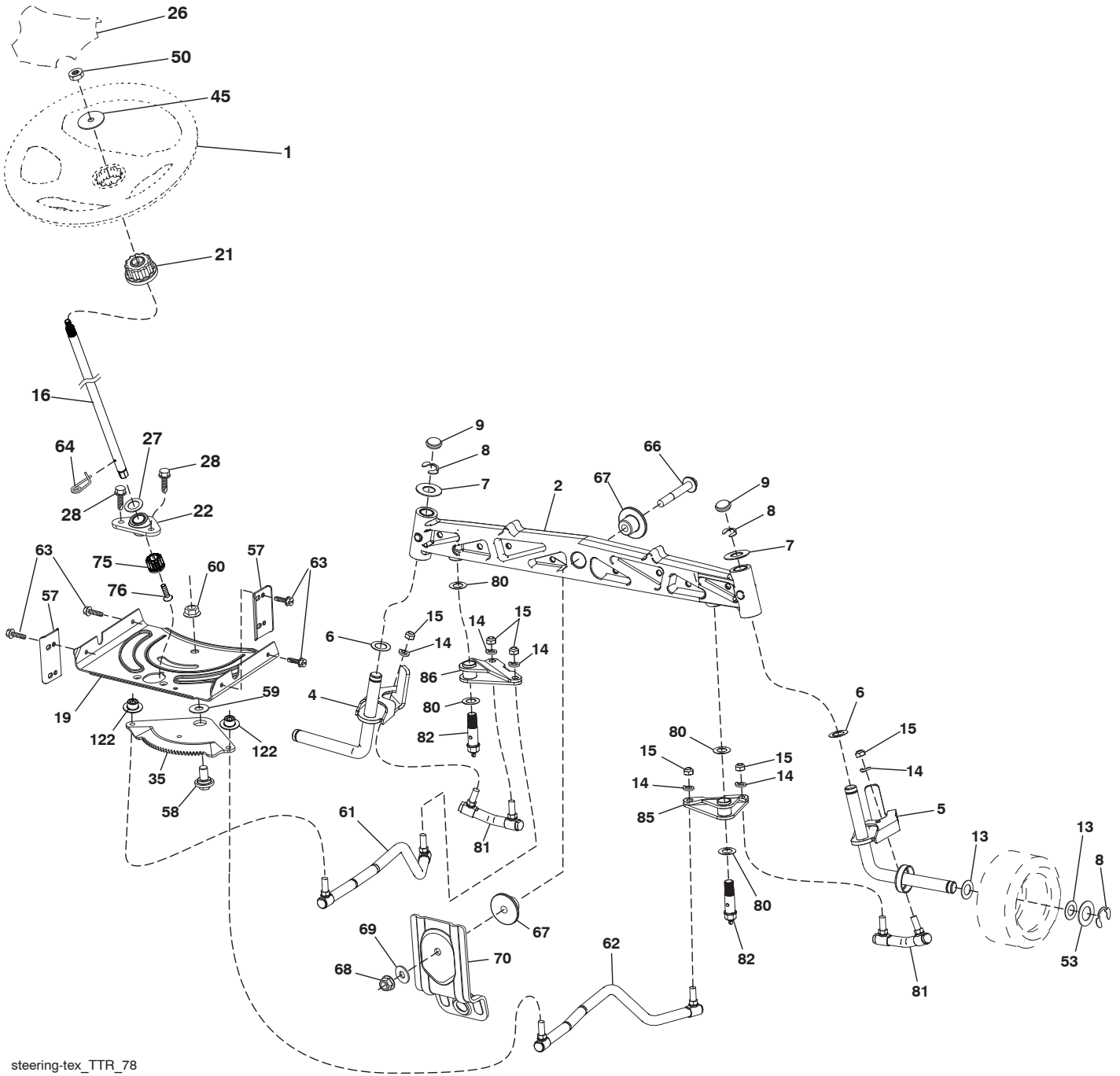

steering-tex_TTR_78

TRACTOR - MODEL NO. YTH 224T (96041033200), PRODUCT NO. 960 41 03-32
STEERING ASSEMBLY 41

KEY NO.	PART NO.	DESCRIPTION
1	532 43 97-40	Wheel, Steering
2	532 43 68-70	Axle Cast Iron
4	532 43 68-73	Spindle Asm., LH
5	532 43 68-74	Spindle Asm., RH
6	532 12 49-31	Washer, Thrust
7	532 12 17-48	Washer 25/32 x 1-5/8 x 16 Ga.
8	812 00 00-29	Ring, Klip #T5304-75
9	532 12 12-32	Cap, Spindle
13	532 12 17-49	Washer 25/32 x 1-1/4 x 16 Ga.
14	810 04 06-00	Washer, Lock Hvy Hlcl Spr 3/8
15	873 54 06-00	Nut, Crown Lock 3/8-24 unf
16	587 01 60-02	Steering Shaft
19	532 19 47-29	Plate Steering
21	532 43 77-47	Adapter, Wheel Steering
22	585 02 99-01	Bearing Shaft
26	532 43 97-43	Insert, Wheel Steering
27	819 21 16-16	Washer 21/32 x 1 x 16 Ga.
28	817 00 06-12	Screw 3/8-16 x 3/4
35	532 44 07-70	Gear, Sector Plate
45	819 18 38-12	Washer 9/16 ID x 2-3/8 OD 12 Ga.
50	873 90 06-00	Nut Lock Flg 3/8-16 unc
53	532 18 89-67	Washer Hardened .793 x 1.637 x .060
57	532 40 74-65	Bracket Upstop
58	532 19 47-47	Bolt Shoulder Sector Pivot CFM
59	532 19 47-48	Washer Thrust Sector Steering
60	873 97 10-00	Nut Flange Lock 5/8-11
61	532 43 68-84	Draglink, LH
62	532 43 68-85	Draglink, RH
63	817 00 05-12	Screw 5/16-18 x 3/4
64	532 19 98-49	Retainer Clip Spring Steering
66	871 02 07-48	Bolt Hex Fghd 7/16-14 x 3 Serr
67	532 19 47-37	Bushing PM Front Axle
68	873 90 07-00	Nut Lock Flange 7/16-14 Gr. 5
69	532 19 91-62	Washer 1.5 x .505 x .118
70	532 19 61-97	Bracket Deck Susp. Front
75	580 68 37-01	Pinion
76	580 68 36-01	Screw Head Sock
80	532 00 13-70	Washer 5/8 x 1.10 x 1/32
81	532 43 68-87	Sub Asm. Link Cross
82	532 44 21-47	Sub Asm. Pivot Bolt
85	532 44 18-73	Sub Asm. Pivot RH
86	532 44 18-72	Sub Asm. Pivot LH
122	532 44 49-62	Cap Gear Sector

NOTE: All component dimensions given in U.S. inches
1 inch = 25.4 mm

TRACTOR - MODEL NO. YTH 224T (96041033200), PRODUCT NO. 960 41 03-32
MOWER DECK 44

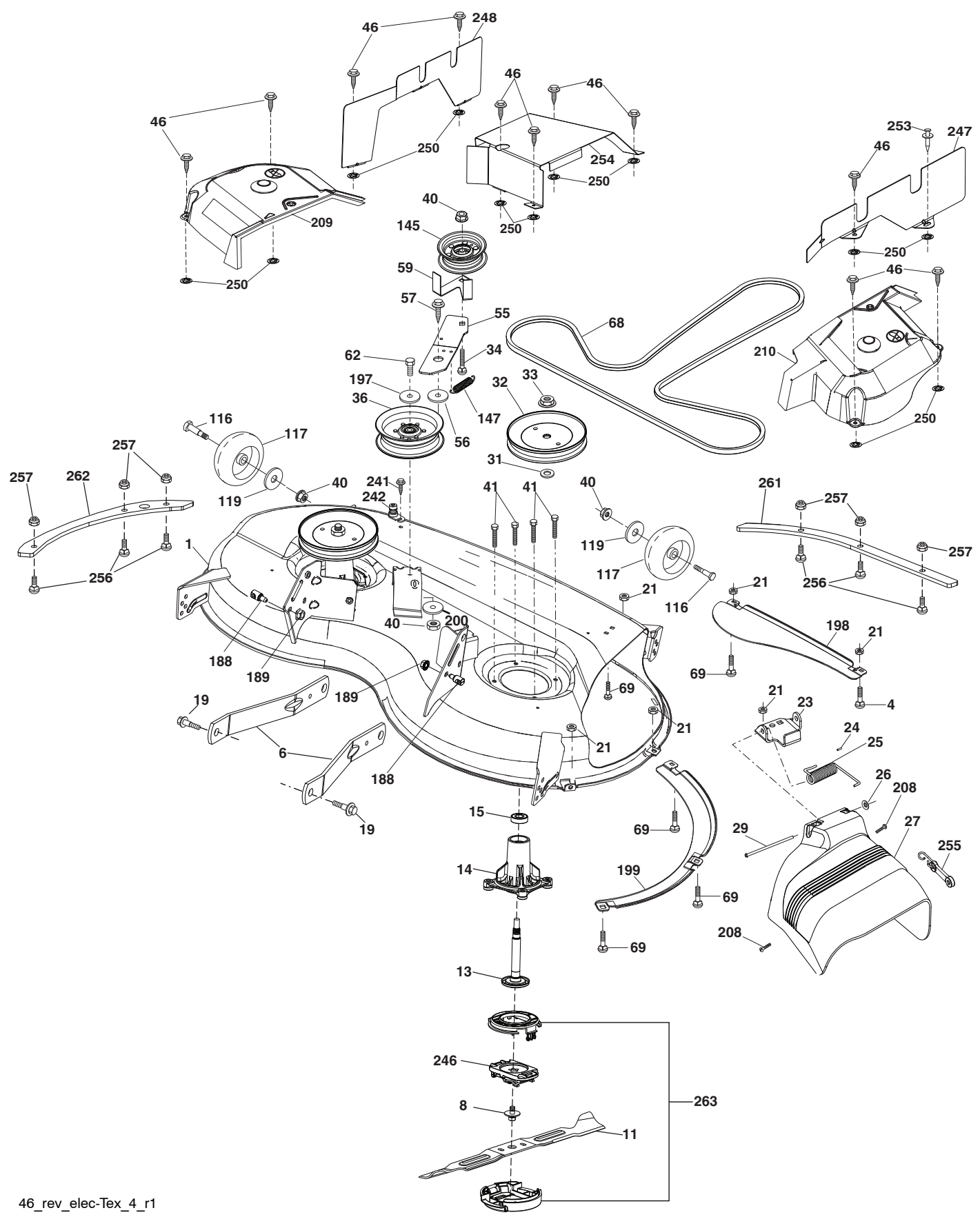

46_rev_elec-Tex_4_r1

**TRACTOR - MODEL NO. YTH 224T (96041033200), PRODUCT NO. 960 41 03-32
MOWER DECK 44**

KEY NO.	PART NO.	DESCRIPTION	KEY NO.	PART NO.	DESCRIPTION
1	583 90 09-02	Mower Housing	147	532 19 72-51	Spring Return
4	874 76 05-12	Bolt Hex Hd 5/16-18 unc	188	532 19 51-61	Stud Fastener
6	532 19 51-86	Arm Suspension	189	873 90 05-00	Nut Lock Hex Flange
8	584 30 93-01	Screw SEMS 7/16-20 x 1	197	819 13 13-12	Washer 13/32 x 13/16 x 12 Ga.
11	581 04 39-01	Blade Mower	198	532 40 31-49	Baffle Center Front
13	580 85 47-01	Shaft Asm. Rev. Tall	199	532 40 31-50	Baffle Front RH
14	580 79 61-01	Housing, Mandrel	200	532 41 35-24	Washer 13/32 x 1 x 1/2 11 Ga.
15	532 11 04-85	Bearing, Ball, Mandrel	208	817 67 06-08	Screw Thdrl 3/8-16 x 1/2
19	532 19 65-39	Bolt, Shoulder	209	532 42 49-86	Cover Mandrel LH
21	873 68 05-00	Nut	210	532 43 10-87	Cover Mandrel RH
23	532 19 25-57	Bracket, Deflector	241	532 15 29-27	Screw
24	532 10 53-04	Cap, Sleeve	242	532 41 55-98	Washout Port
25	532 19 70-26	Spring, Torsion, Deflector	246	580 95 40-03	Blade Holder
26	532 11 04-52	Nut, Push	247	532 43 02-63	Shield Deck RH
27	532 44 28-95	Shield, Deflector	248	532 43 02-62	Shield Deck LH
29	532 13 14-91	Rod, Hinge	250	532 42 30-62	Palnut 1/4
31	532 18 76-90	Washer, Spacer	253	532 42 73-50	Rivet Tuflok .25 x .24
32	532 19 74-73	Pulley, Mandrel	254	532 43 02-64	Shield Deck Rear
33	532 40 02-34	Nut, Toplock, Flanged	255	532 43 60-87	Kit Strap Bungee
34	872 11 06-12	Bolt Carr Sh. 3/8-16 x 1-1/2 Gr. 5	256	578 29 64-04	Screw Buttonhead 5/16-18
36	532 19 73-79	Pulley, Idler, Flat	257	873 90 04-00	Nut Hex Flange 1/4-20
40	873 90 06-00	Nut, Lock Flg. 3/8-16 unc	261	585 31 77-05	Plate Reinforcement Front
41	584 95 39-01	Bolt Hex Washer Head 3/8-16 x 1.19	262	585 31 78-05	Plate Reinforcement Side
46	532 13 77-29	Screw	263	586 63 85-01	Upper/Lower Cap Asm.
55	532 19 72-49	Arm, Idler	--	580 85 60-01	Mandrel Assembly-Tall (Includes Housing (Key #14), Shaft Assembly (Key #13), and Bearing Only (Key #15) Pulley/Nut/Washer and Blade Bolt/Washers Not Included)
56	532 19 90-92	Spacer, Retainer			
57	817 00 06-16	Screw Hexwsh Thd 3/8-16 x 1			
59	532 14 10-43	Guard, Tuv Idler (94)			
62	874 52 06-36	Bolt 3/8-16 unc x 2-1/4 Gr. 5			
68	532 40 51-43	V-Belt	--	586 26 49-01	Replacement Mower, Complete
69	872 14 05-05	Bolt			
116	532 19 34-06	Bolt, Shoulder			
117	532 17 48-73	Wheel, Gauge			
119	819 13 20-12	Washer 13/32 x 1-1/2 x 11 Ga.			
145	532 19 31-97	Pulley Idler			

NOTE: All component dimensions given in U.S. inches
1 inch = 25.4 mm

TRACTOR - MODEL NO. YTH 224T (96041033200), PRODUCT NO. 960 41 03-32
MOWER LIFT 45

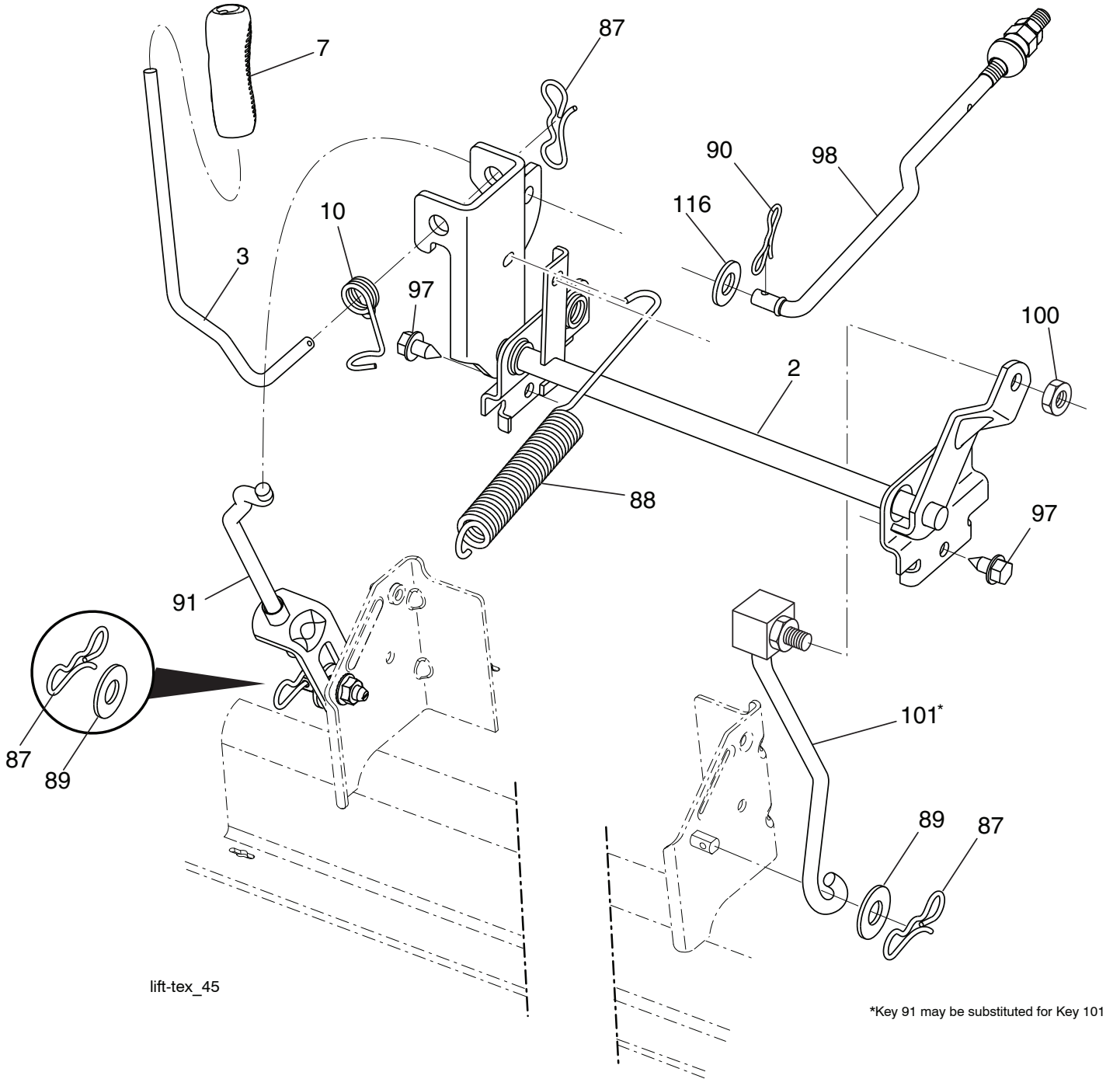

KEY NO.	PART NO.	DESCRIPTION
2	532 42 20-27	Shaft Asm., Lift
3	532 19 52-30	Lever Asm., Lift RH
7	580 96 23-01	Grip, Lever
10	532 19 63-14	Spring Torsion
87	532 19 42-09	Pin Cotter 7/16 Bow Tie Lock
88	532 41 07-10	Spring Lift Assist
89	819 19 19-12	Washer Clear Zinc
90	532 19 42-08	Pin Cotter 5/16 Bow Tie Lock
91	532 19 51-81	Lift Link Asm. Rear

KEY NO.	PART NO.	DESCRIPTION
97	817 00 06-12	Screw 3/8-16 x .75 Smgml. Tap/R.Z
98	532 19 52-70	Link Asm. Susp. Front Mower
100	873 93 06-00	Nut 3/8-16 unc
101	532 40 70-03	Link Asm. Lift Fixed
116	819 15 15-16	Washer 15/32 x 15/16 x 16 Ga.

NOTE: All component dimensions given in U.S. inches
 1 inch = 25.4 mm

**TRACTOR - MODEL NO. YTH 224T (96041033200), PRODUCT NO. 960 41 03-32
SEAT ASSEMBLY 42**

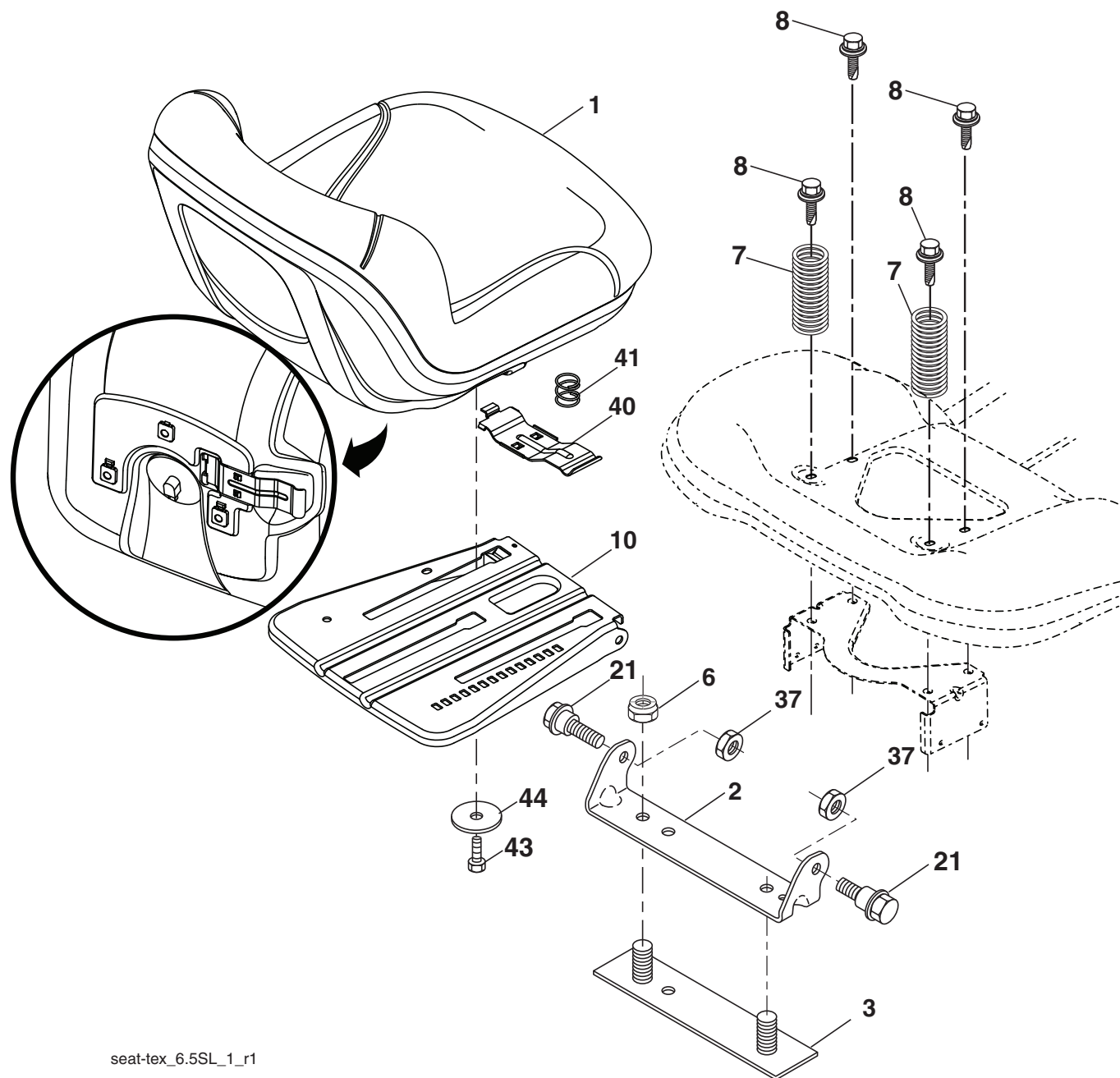

seat-tex_6.5SL_1_r1

KEY NO.	PART NO.	DESCRIPTION
1	532 43 98-22	Seat
2	532 18 01-66	Bracket Pivot Fender
3	532 14 06-75	Strap, Asm. Fender
6	873 80 06-00	Nut, Lock w/Ins. 3/8-16 unc
7	532 12 41-81	Spring, Seat Cprsn.
8	532 17 18-77	Bolt 5/16-18 x 3/4 unc w/Sems.
10	532 19 69-77	Pan, Seat
21	532 17 18-52	Bolt, Shoulder 5/16-18

KEY NO.	PART NO.	DESCRIPTION
37	873 80 05-00	Nut, Lock 5/16-18 unc
40	532 19 76-61	Handle Slide Seat
41	532 19 82-00	Spring Latch Seat
43	874 76 06-12	Bolt 3/8-16 x 3/4
44	819 13 38-12	Washer 13/32 x 2-3/8 x 12 Ga.

NOTE: All component dimensions given in U.S. inches
1 inch = 25.4 mm

