

# ILLUSTRATED PARTS LIST

**MFG. ID NO. 96041032000**

**CUSTOMER CATALOG NO. YTH 224TFi**

**PRODUCT NO. 960 41 03-20**

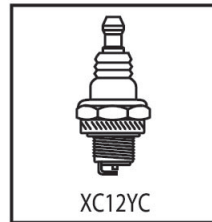
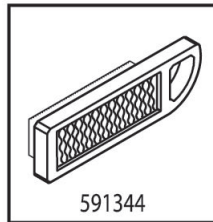

**47**

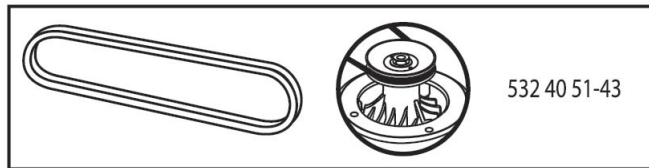
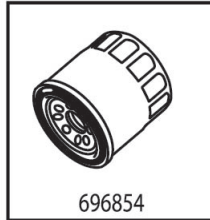
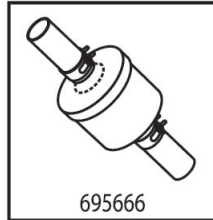

585863501

**TRACTOR -- MODEL NO. YTH 224TFi (96041032000), PRODUCT NO. 960 41 03-20  
DECALS 27**

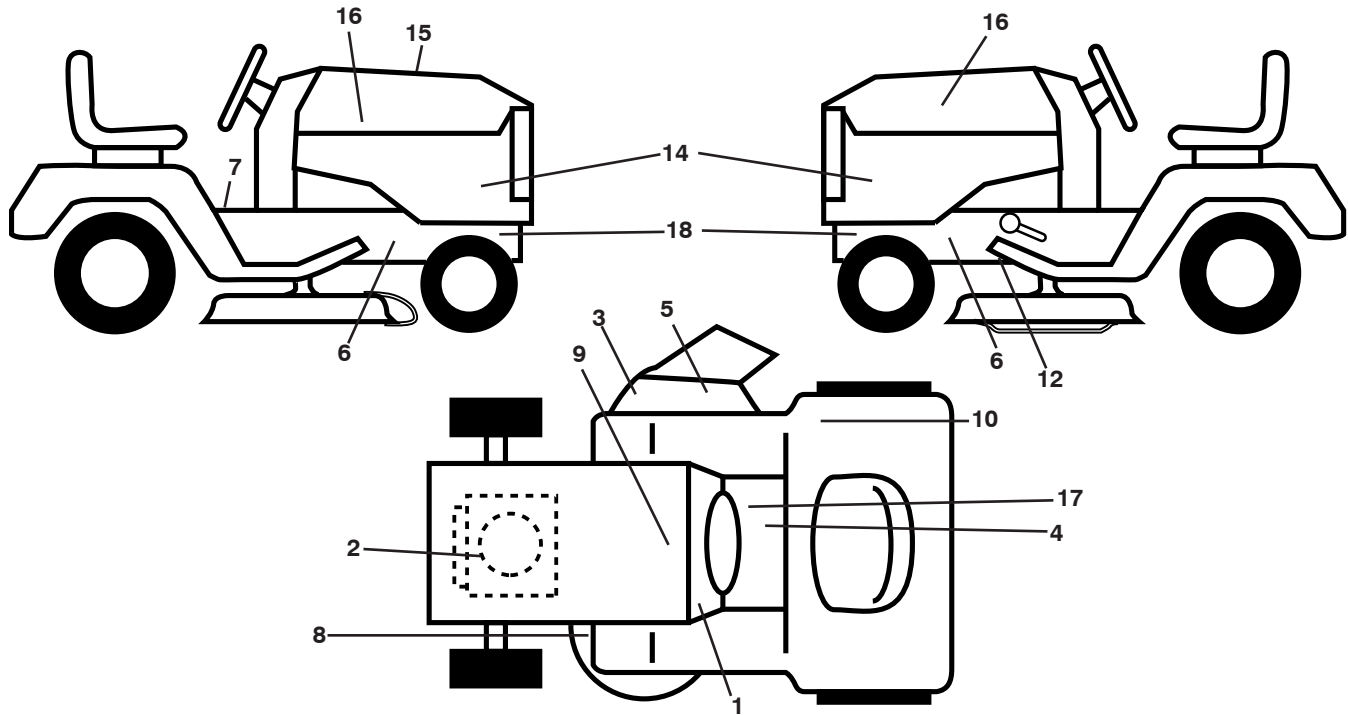

KEY NO.	PART NO.	DESCRIPTION
1	586 06 62-01	Decal, Snowflake
2	586 00 10-01	Decal, Engine
3	581 57 92-01	Decal, Warning
4	586 80 03-01	Decal, Tractor Saddle
5	584 90 46-01	Decal, Deflect. Warning
6	581 57 98-01	Decal, Warning
7	586 34 95-01	Decal, Warning Symbols
8	581 58 00-01	Decal, Mower Sch.
9	532 14 50-05	Decal, Battery Dan./Poi.
10	581 72 41-01	Decal, Certification
12	532 41 86-00	Decal, Pedal Dealer

KEY NO.	PART NO.	DESCRIPTION
14	586 27 11-01	Decal, Panel Side
15	585 86 35-01	Decal, Replacement Parts
16	581 62 73-01	Decal, Hood Logo
17	581 57 81-01	Decal, Read Owner Manual
18	581 57 96-01	Decal, Chassis Hot Muffler
--	581 72 46-01	Decal, Drawbar Load Limit
--	581 72 48-01	Decal, Bypass
--	532 43 98-82	Pad, Footrest, LH
--	532 43 98-81	Pad, Footrest, RH
--	586 21 94-40	Manual, Operator's (Euro)

**WHEELS AND TIRES**

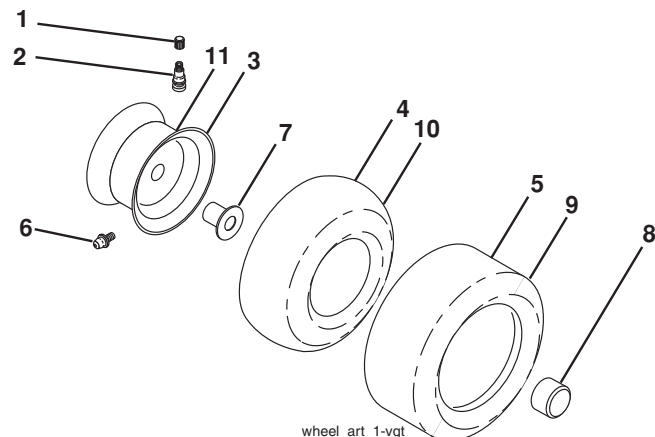

KEY NO.	PART NO.	DESCRIPTION
1	532 05 91-92	Cap, Valve, Tire
2	532 06 51-39	Stem, Valve
3	532 13 83-36	Rim Assembly, Front
4	532 05 99-04	Tube, Front (Service Item Only)
5	532 10 62-22	Tire, Front 15 x 6-6
6	532 12 49-57	Fitting, Grease (Front Wheel Only)
7	532 12 49-59	Bearing, Flange (Front Wheel Only)
8	532 17 50-39	Cap, Axle (Front Wheel Only)
9	532 12 20-82	Tire, Rear 20 x 10-8
10	532 12 49-26	Tube, Rear (Service Item Only)
11	532 13 83-37	Rim Assembly, Rear
--	532 14 43-34	Sealant, Tire (10 oz. Tube)

**NOTE:** All component dimensions given in U.S. inches  
1 inch = 25.4 mm

# TRACTOR -- MODEL NO. YTH 224TFi (96041032000), PRODUCT NO. 960 41 03-20

## SCHEMATIC **38**

SCH28

### SMART IGNITION SWITCH (S.I.S.)



-DO NOT OPEN!  
-PERMANENT DAMAGE CAN RESULT  
IF PROPER DIAGNOSTIC PROCEDURES  
ARE NOT FOLLOWED.  
-CONTACT YOUR DEALER OR AUTHORIZED  
SERVICE CENTER FOR REPAIR.



SENSITIVE ELECTRONIC  
COMPONENTS INSIDE!



(COLOR: CONNECTOR NUMBER - PIN NUMBER)

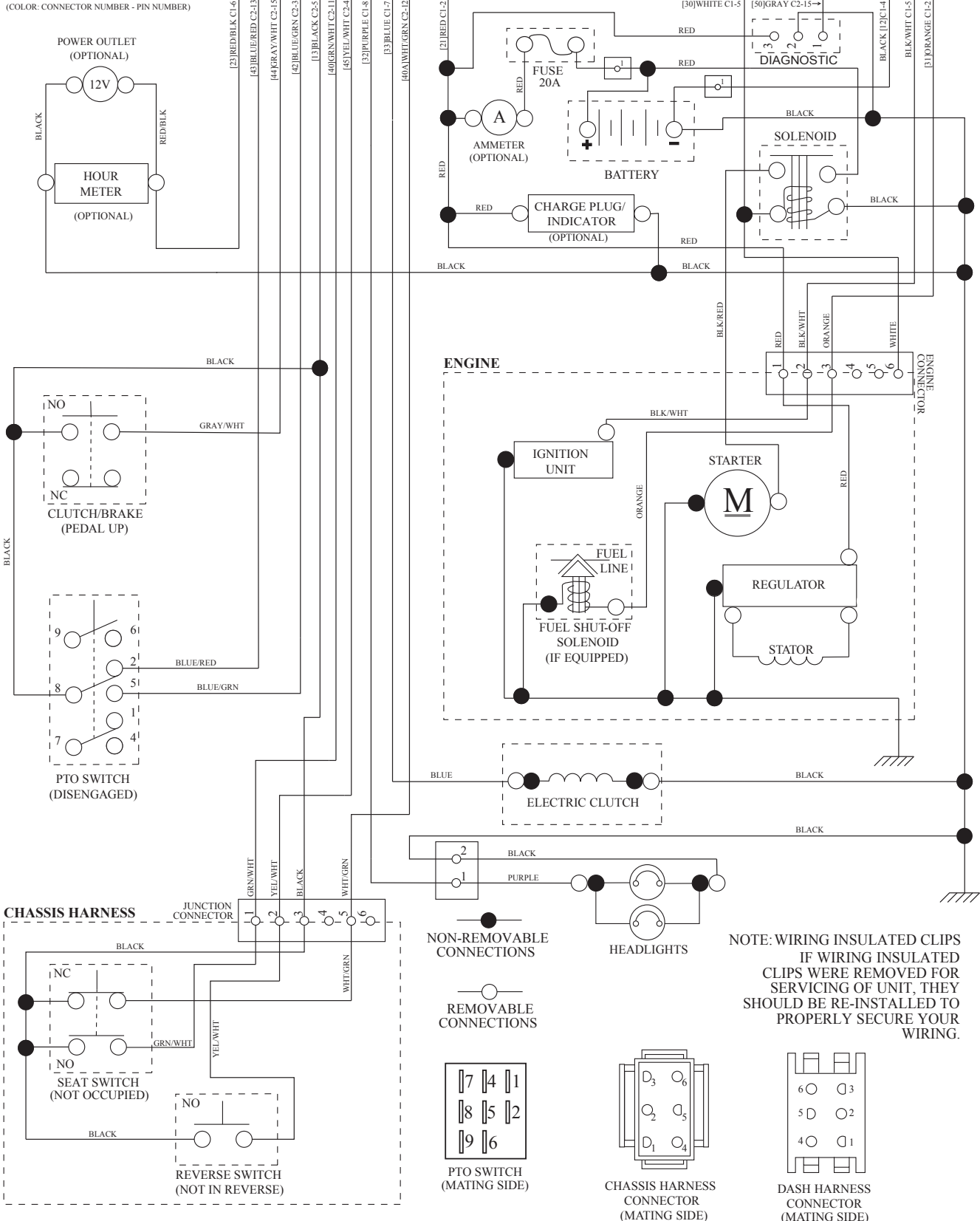

**TRACTOR -- MODEL NO. YTH 224TFi (96041032000), PRODUCT NO. 960 41 03-20**  
**ELECTRICAL 32**

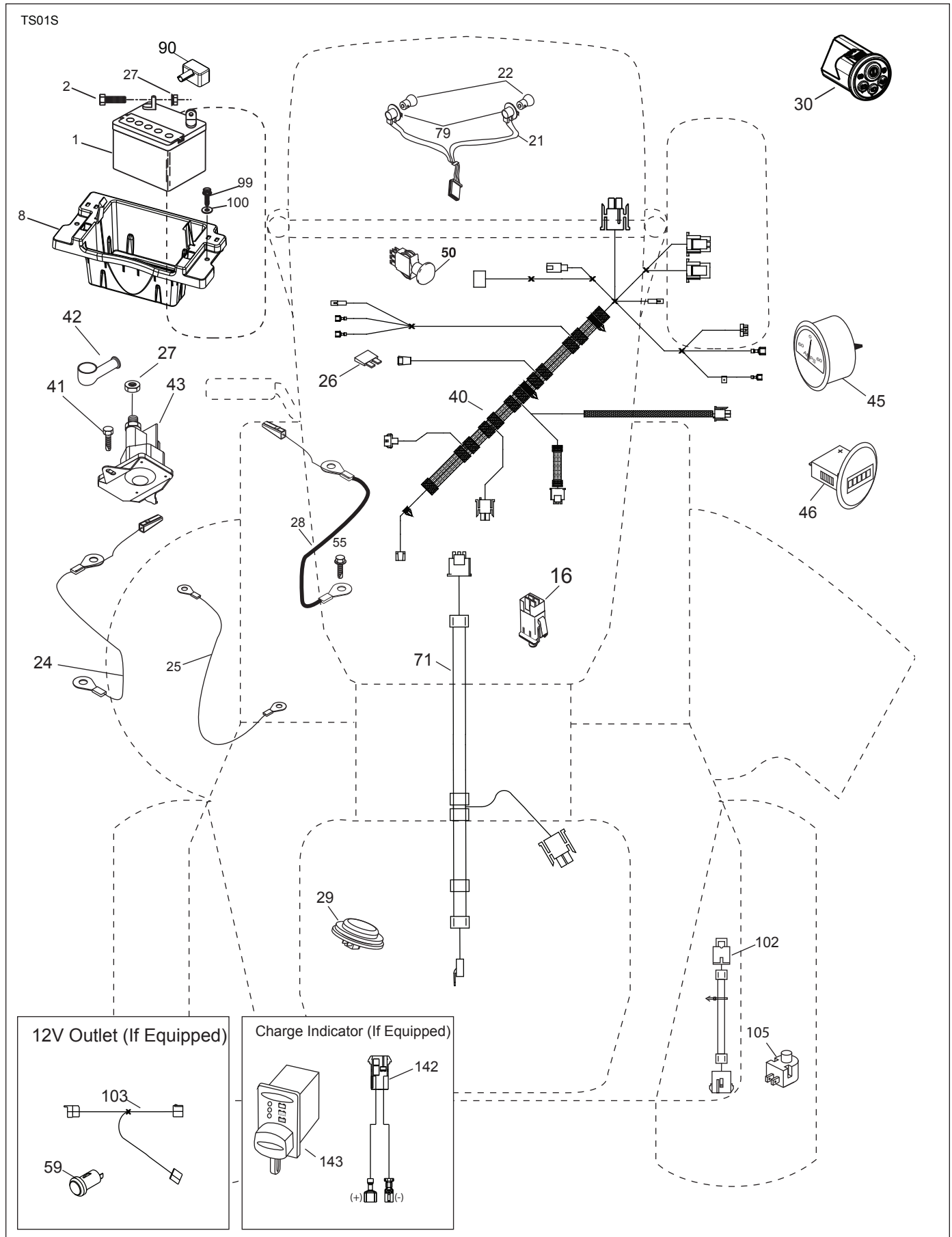

**TRACTOR - - MODEL NO. YTH 224TFi (96041032000), PRODUCT NO. 960 41 03-20  
ELECTRICAL 32**

KEY PART NO. NO.	DESCRIPTION
1 532 16 34-65	Battery
2 874 76 04-12	Bolt Hex Hd. 1/4-20 unc x 3/4
8 587 20 51-01	Battery Box
16 532 17 61-38	Switch Interlock
21 532 40 02-52	Harness Light w/4152J
22 532 00 41-52	Bulb, Light # 1156
24 585 73 43-01	Cable Battery
25 585 55 55-01	Cable Starter
26 532 17 51-58	Fuse
27 873 51 04 00	Nut Keps Hex 1/4-20 unc
28 585 30 69-01	Cable Ground
29 581 42 93-02	Switch Seat
30 586 83 67-01	Switch Asm. Smart
40 585 26 36-02	Harness Ign. Dash
41 817 72 04-08	Screw 1/4-20 x 1/2
42 532 13 15-63	Cover Terminal
43 532 19 25-07	Solenoid
45 587 55 39-03	Ammeter Guage Round
46 587 55 40-03	Hourmeter Gauge
50 532 17 46-51	Switch PTO
55 817 06 05-12	Screw 5/16-18 x 3/4
71 585 21 60-01	Harness Ign. Chassis
79 532 17 52-42	Socket Asm. Bulb
90 532 43 53-95	Cover Terminal Battery
99 817 67 04-12	Screw Hex Wsh. Thdrol. 1/4-20 x 3/4
100 819 09 14-16	Washer 9/32 x 7/8 x 16 Ga.
102 532 40 44-54	Harness Pigtail Tex ROS Tufftorq
105 532 40 75-68	Switch Reverse
142 583 85 78-01	Charge Port Pigtail
143 532 44 80-59	Charge Port

**NOTE:** All component dimensions given in U.S. inches  
1 inch = 25.4 mm

TRACTOR -- MODEL NO. YTH 224TFi (96041032000), PRODUCT NO. 960 41 03-20  
CHASSIS AND ENCLOSURES 39

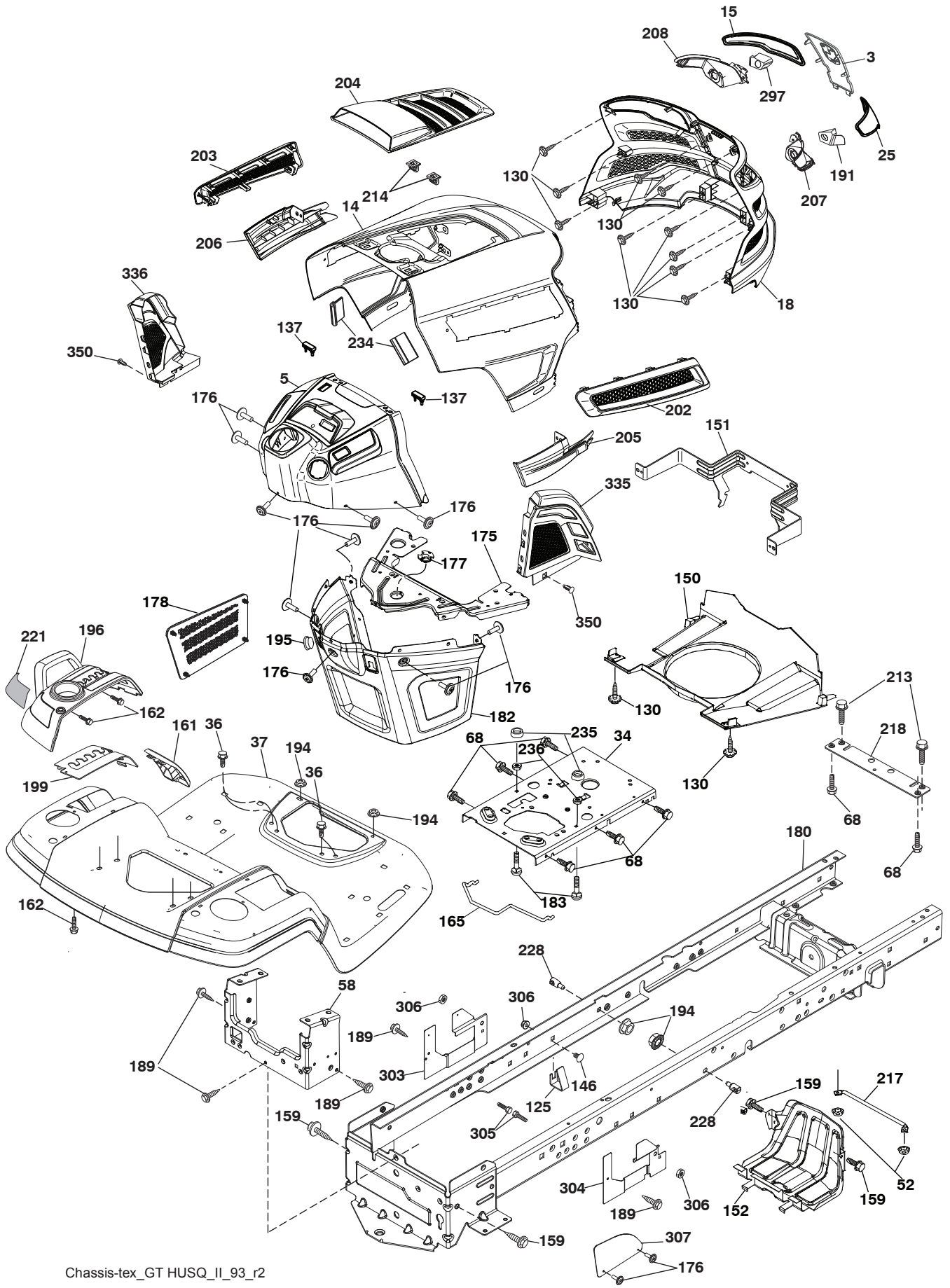

Chassis-tex\_GT HUSQ\_II\_93\_r2

**TRACTOR - - MODEL NO. YTH 224TFi (96041032000), PRODUCT NO. 960 41 03-20  
CHASSIS AND ENCLOSURES 39**

KEY NO.	PART NO.	DESCRIPTION	KEY NO.	PART NO.	DESCRIPTION
3	532 44 44-81	Applique Sub Asm.	195	532 40 41-37	Plug 12 V Adapter
5	581 67 42-02	Dash	196	532 43 97-16	Console Asm. Deck Lift
14	532 44 11-77	Hood	199	532 19 82-59	Plate Deck Lift
15	532 43 97-33	Lens LH	202	532 43 97-28	Vent Side Hood RH
18	532 44 06-53	Grille	203	532 43 97-27	Vent Side Hood LH
25	532 44 33-85	Lens RH	204	532 43 57-14	Vent Asm. Hood Top
34	580 91 08-01	Plate Engine	205	532 43 97-30	Skirt Hood Side RH
36	817 06 05-12	Screw 5/16-18 x 3/4	206	532 43 97-29	Skirt Hood Side LH
37	532 44 12-08	Fender	207	532 43 97-34	Bezel RH
52	873 68 05-00	Nut Crownlock 5/16-18	208	532 43 97-35	Bezel LH
58	532 41 22-81	Drawbar Upper	213	874 76 05-12	Bolt Hex Hd. 5/16-18 unc x 3/4
68	817 49 05-08	Screw 5/16-18 x 1/2	214	532 19 91-45	Clip Retainer
125	581 68 48-01	Clip Fuel Line	217	532 40 91-67	Rod Pivot
130	532 41 63-58	Screw #10 x 0.750	218	532 19 63-95	Hood Stop
137	532 40 75 90	Bumper Dash	221	532 19 89-09	Reflector LH
146	581 85 79-01	Bolt	228	532 19 51-61	Stud Fastener
150	532 43 97-74	Duct Heat Hood	234	532 40 47 42	Bumper Hood
151	532 43 66-70	Pivot Bracket	235	532 40 61 29	Spacer Fender
152	532 43 98-70	Shield Browning/Debris	236	873 93 05-00	Nut 5/16-18 unc
159	817 00 06-12	Screw 3/8-16 x 3/4 BL	297	532 43 74 56	Insert Reflective LH
161	532 43 99-29	Console Fuel Window	303	532 42 09-59	Shield Chassis Fren LH
162	532 14 24-32	Screw Hex Wsh. Hi-Lo 1/4 x 1/2	304	532 42 15-09	Shield Chassis Fren RH
165	532 19 68-26	Bracket Support Tank	305	872 11 06-06	Bolt 3/8-16 x 3/4
175	532 19 63-04	Crossmember	306	873 90 06-00	Nut 3/8-16 unc
176	532 40 07-76	Screw #10-24 x 5/8	307	532 42 45-70	Shield Upper Pedal
177	532 19 52-28	Bushing Steering	335	532 44 82-04	Lower Dash Cover RH
178	532 19 97-82	Cargo Asm. Net	336	532 44 53-09	Lower Dash Cover LH
180	532 41 50-64	Chassis	350	532 44 51-43	Clip X-mas Tree
182	532 40 68-59	Dash Lower	--	532 43 18-82	Kit Guard Brush
183	874 52 05-20	Bolt 5/16-18 unc x 1-1/4	--	586 29 76-01	Plug Light Switch
189	817 00 05-12	Screw 5/16-18 x 3/4			
191	532 43 74-55	Insert Reflective RH			
194	873 90 05-00	Nut Lock Hex Flange 5/16-18			

**NOTE:** All component dimensions given in U.S. inches  
1 inch = 25.4 mm

**TRACTOR -- MODEL NO. YTH 224TFi (96041032000), PRODUCT NO. 960 41 03-20**  
**DRIVE 40**

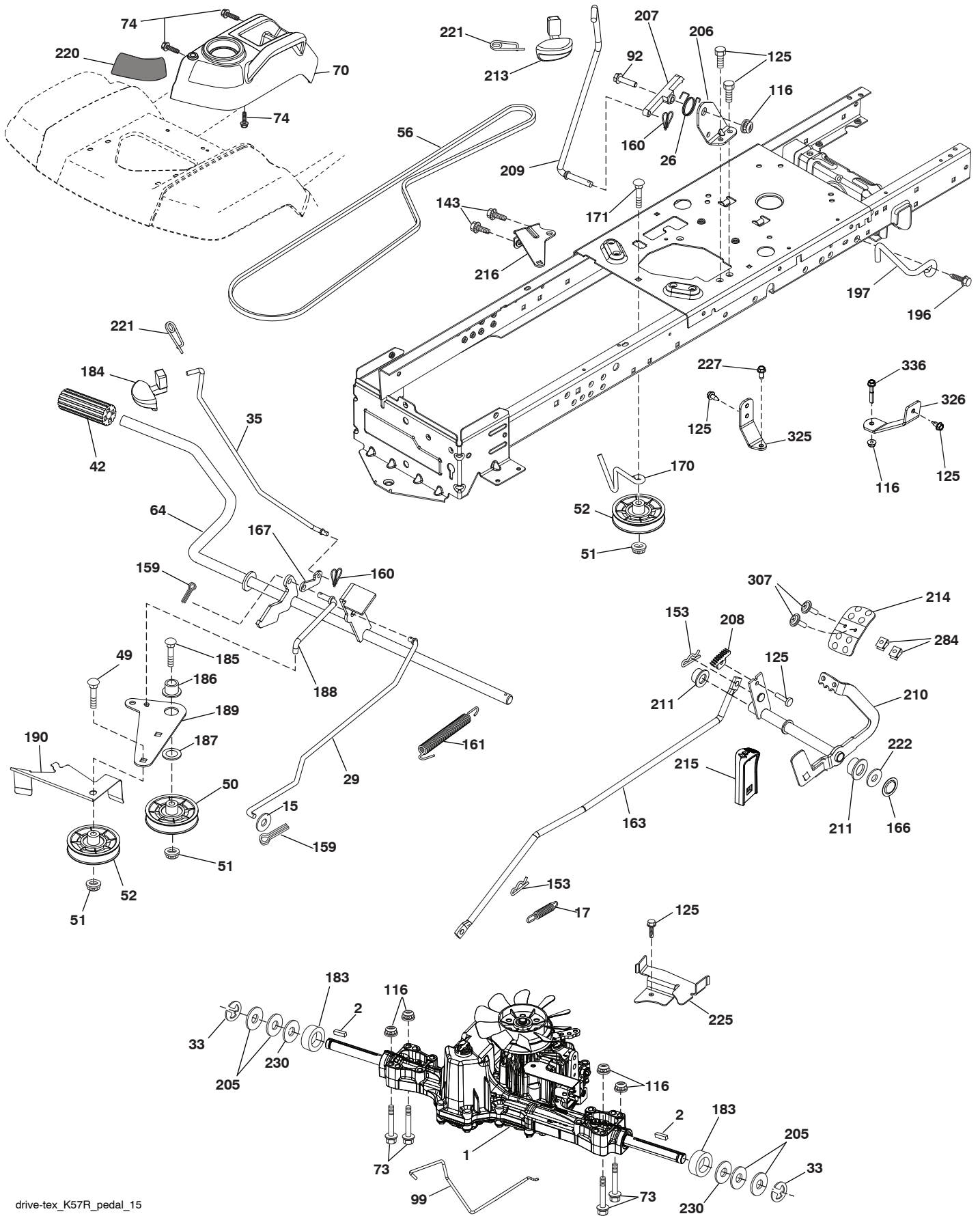



**TRACTOR - - MODEL NO. YTH 224TFi (96041032000), PRODUCT NO. 960 41 03-20  
DRIVE **40****

KEY NO.	PART NO.	DESCRIPTION	KEY NO.	PART NO.	DESCRIPTION
1	---	Transaxle, TuffTorq K57R (437814) (Order parts from transaxle manufacturer.)	186	532 19 43-21	Spacer Retainer
2	532 12 35-83	Key	187	819 13 32-10	Washer
15	819 13 13-16	Washer 13/32 x 13/16 x 16 Ga.	188	532 19 43-23	Link Clutch Ground Drive
17	532 41 36-78	Spring, Brake	189	532 19 43-17	Bellcrank Ground Drive
26	532 19 96-79	Spring Return Cruise	190	532 19 43-18	Keeper Bellcrank Ground Drive
29	532 40 38-06	Rod, Brake	196	817 00 06-16	Screw 3/8-16 x 1
33	812 00 00-01	Ring E	197	585 65 86-01	Link Clutch Anti-Rotation
35	583 86 45-01	Rod, Brake, Park	205	532 12 17-48	Washer 25/32 x 1-5/8 x 16 Ga.
42	532 12 48-72	Cover, Foot Pedal	206	532 44 85-96	Bracket Mount Latch Cruise
49	872 11 06-14	Bolt	207	532 19 78-68	Latch Control Cruise
50	532 19 43-27	Pulley Idler Flat	208	532 19 78-69	Gear Sector Control Cruise
51	873 90 06-00	Lock Nut 3/8-16	209	532 19 95-92	Rod Control Cruise
52	532 19 43-26	Idler V-Groove	210	532 19 78-60	Rocker Asm Cruise
56	532 13 09-69	V-Belt, Drive	211	532 12 01-83	Bearing Nylon
64	532 19 78-65	Shaft Asm. Pedal Brake Control	213	532 40 31-19	Handle Parking Brake
70	532 43 96-61	Console Asm.	214	532 41 68-63	Pedal Forward Pad
73	874 49 05-40	Bolt 5/16-18 x 1/2 Gr 5	215	532 41 94-82	Pedal Reverse Pad
74	532 14 24-32	Screw Hx Wsh Hi-Lo 1/4 x 1/2 unc	216	532 19 61-31	Bracket Pulley Idler
92	874 76 05-20	Bolt Fin Hex 5/16-18 unc x 1.25	220	532 19 89-08	Reflector RH
99	532 41 57-42	Rod Bypass	221	532 40 31-87	Retainer Spring Clip Handle
116	873 90 05-00	Nut Lock Hex Flange 5/16-18	222	879 21 20-10	Washer 21/32 x 1-1/4 10 Ga.
125	817 00 05-12	Screw 5/16-18 x 3/4	225	532 40 33-19	Keeper Belt Trans.
143	817 49 05-08	Screw 5/16-18 x 1/2	227	817 49 05-12	Screw Thdrol 5/16-18 x 3/4
153	532 12 47-88	Retainer Spring	230	532 18 89-67	Washer Hardened
159	876 02 04-12	Pin Cotter 1/8 x 3/4	284	532 41 76-93	Nut U-Channel
160	532 16 94-84	Retainer Clip	307	874 18 04-12	Screw
161	532 10 57-09	Spring, Return, Clutch	325	585 66 85-02	Bracket
163	532 44 82-75	Rod Pedal Control	326	585 67 08-02	Bracket
166	532 42 91-64	Nut Push .625	336	587 25 96-01	Bolt
167	532 40 52-57	Latch Brake Parking			
170	532 19 43-22	Keeper Belt Centerspan			
171	872 11 06-16	Bolt			
183	532 13 70-57	Spacer Axle			
184	532 44 14-55	Handle Parking Brake			
185	872 11 06-22	Bolt			

**NOTE:** All component dimensions given in U.S. inches  
1 inch = 25.4 mm

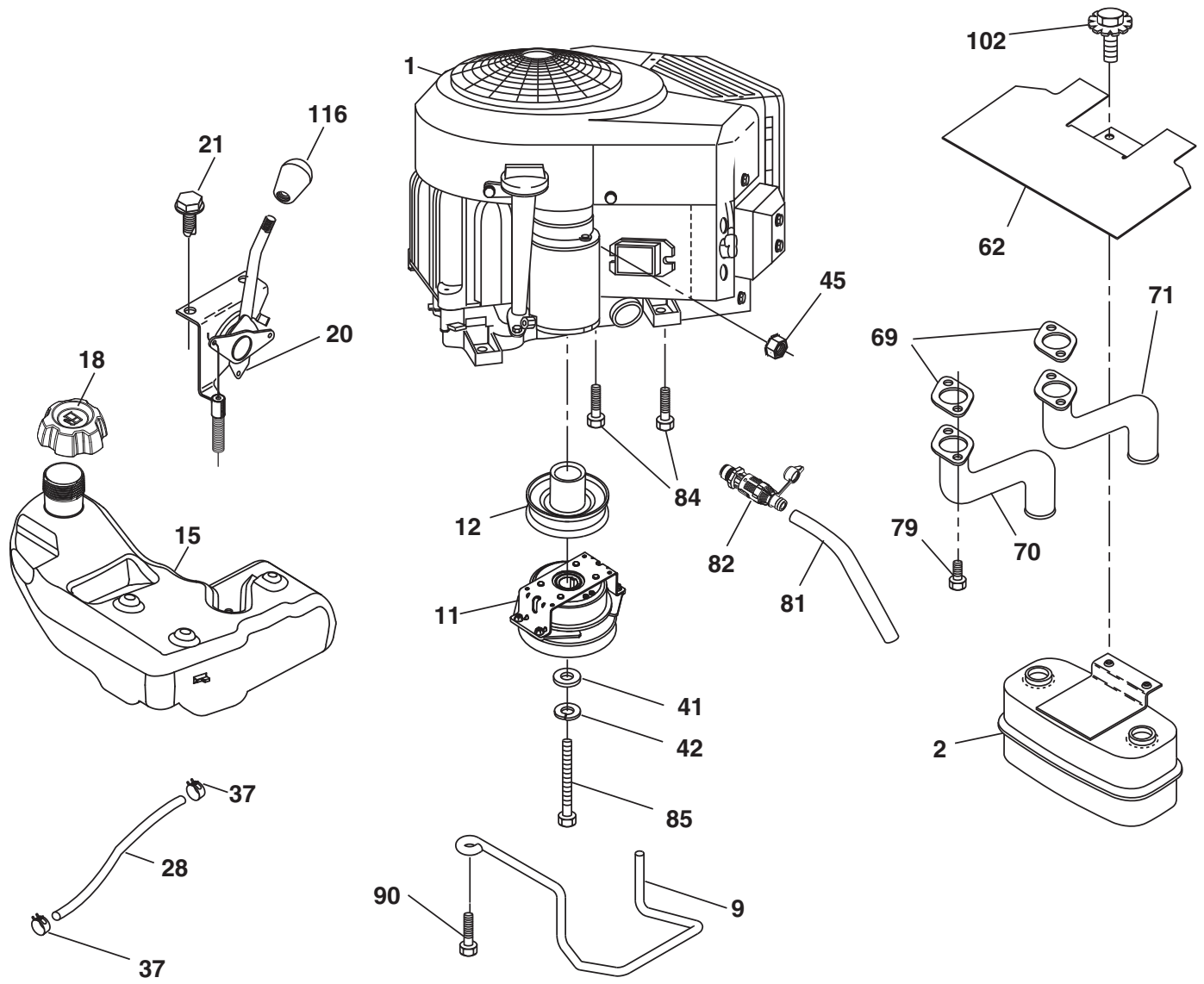

**SPARK ARRESTER KIT**

engine-tex\_bs-2cyl\_122\_r1

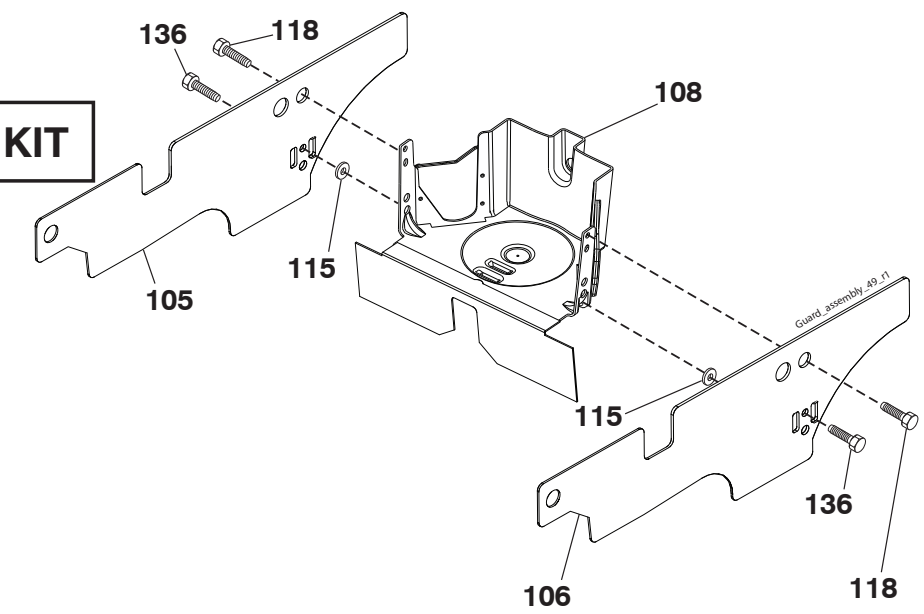

**TRACTOR - - MODEL NO. YTH 224TFi (96041032000), PRODUCT NO. 960 41 03-20  
ENGINE 24**

KEY NO.	PART NO.	DESCRIPTION
1	- - - - -	Briggs&Stratton 40R877-0005-B1 (585700601)(Order parts from engine manufacturer.)
2	532 44 59-62	Muffler
9	584 90 80-01	Keeper Belt Engine
11	587 24 16-01	Clutch Electric
12	532 40 50-97	Pulley Engine
15	532 19 34-99	Tank Fuel 4.0
18	532 43 96-45	Cap Fuel
20	532 42 43-40	Control Throttle
21	532 41 63-58	Screw #10 x 0.750
28	532 14 21-58	Fuel Line
29	532 13 71-80	Spark Arrester Kit
37	532 12 34-87	Clamp Hose
41	532 12 61-97	Washer 1-1/2 OD x 15/32 ID x .250
42	810 04 07-00	Washer Lock 7/16
45	873 51 04-00	Nut Keps 1/4-20 unc
62	532 43 40-17	Shield Heat Muffler
69	532 16 53-91	Gasket
70	581 88 11-01	Tube Exhaust LH
71	581 88 10-01	Tube Exhaust RH
79	532 18 39-06	Screw
81	532 14 84-56	Tube Drain Oil Easy
82	532 42 82-87	Valve Oil Drain
84	817 06 06-20	Screw
85	532 17 99-53	Bolt 7/16-20 x 3.75 Gr.
90	817 00 06-16	Screw 3/8-16 x 1
102	817 00 05-12	Screw 5/16-18 x 3/4
105	532 41 56-06	Shield Side LH
106	532 41 56-11	Shield Side RH
108	532 42 68-03	Cover Asm. Engine
115	532 42 30-62	Palnut 1/4
116	539 13 26-24	Knob Shift
118	817 67 05-08	Screw 5/16-18 x 1/2
136	532 13 77-29	Screw 1/4-20 x 5/8

**NOTE:** All component dimensions given in U.S. inches  
1 inch = 25.4 mm

TRACTOR -- MODEL NO. YTH 224TFi (96041032000), PRODUCT NO. 960 41 03-20  
STEERING ASSEMBLY **41**

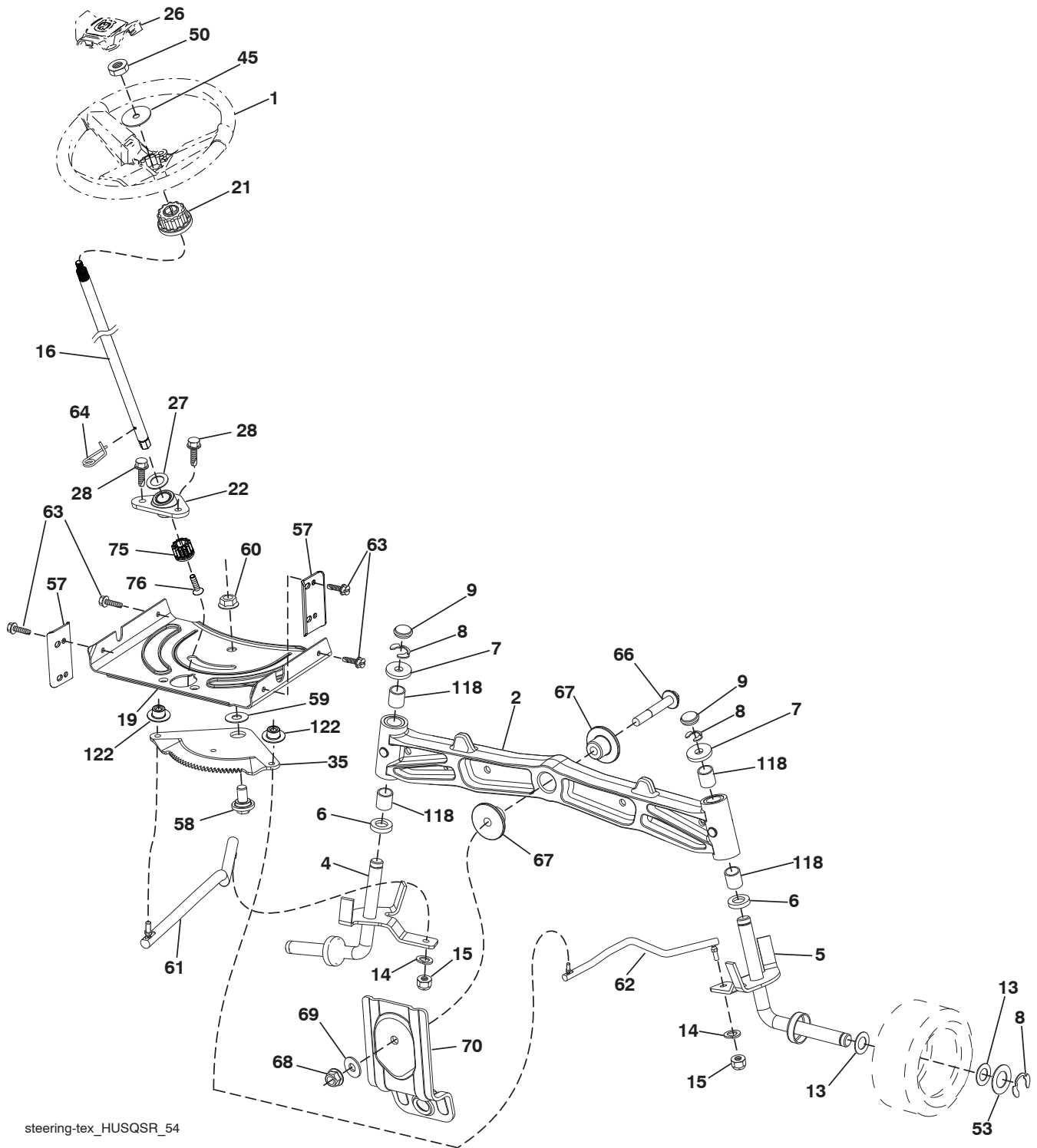

steering-tex\_HUSQSR\_54

**TRACTOR - - MODEL NO. YTH 224TFi (96041032000), PRODUCT NO. 960 41 03-20  
STEERING ASSEMBLY 41**

<b>KEY NO.</b>	<b>PART NO.</b>	<b>DESCRIPTION</b>
1	532 43 97-40	Wheel, Steering
2	532 41 35-91	Axle Cast Iron
4	532 40 30-87	Spindle Asm., LH
5	532 40 30-88	Spindle Asm., RH
6	532 12 49-31	Washer, Thrust
7	532 12 17-48	Washer 25/32 x 1-5/8 x 16 Ga.
8	812 00 00-29	Ring, Klip #T5304-75
9	532 12 12-32	Cap, Spindle
13	532 12 17-49	Washer 25/32 x 1-1/4 x 16 Ga.
14	810 04 06-00	Washer, Lock Hvy Hlcl Spr 3/8
15	873 54 06-00	Nut, Crown Lock 3/8-24 unf
16	587 01 60-02	Steering Shaft
19	532 19 47-29	Plate Steering
21	586 84 02-01	Adapter Wheel Steering
22	585 02 98-02	Bearing
26	532 43 97-43	Insert, Wheel Steering
27	819 21 16-16	Washer
28	817 00 06-12	Screw 3/8-16 x 3/4
35	532 19 47-32	Gear, Sector Plate
45	587 01 64-01	Washer 3/8 ID 2-3/8 OD 12 Ga. PLTD
50	873 90 06-00	Nut Lock Flg 3/8-16 unc
53	532 18 89-67	Washer Hardened .793 x 1.637 x .060
57	532 40 74-65	Bracket Upstop
58	532 19 47-47	Bolt Shoulder Sector Pivot CFM
59	532 19 47-48	Washer Thrust Sector Steering
60	873 97 10-00	Nut Flange Lock 5/8-11
61	532 19 47-40	Draglink, LH
62	532 19 47-41	Draglink, RH
63	817 00 05-12	Screw 5/16-18 x 3/4
64	532 19 98-49	Retainer Clip Spring Steering
66	871 02 07-48	Bolt Hex Fghd 7/16-14 x 3 Serr
67	532 19 47-37	Bushing PM Front Axle
68	873 90 07-00	Nut Lock Flange 7/16-14 Gr. 5
69	532 19 91-62	Washer 1.5 x .505 x .118
70	532 19 61-97	Bracket Deck Susp. Front
75	580 68 37-02	Pinion
76	580 68 36-01	Screw Head Sock
118	532 40 60-13	Bushing Axle
122	532 44 49-62	Cap Gear Sector

**NOTE:** All component dimensions given in U.S. inches  
1 inch = 25.4 mm

**TRACTOR - - MODEL NO. YTH 224TFi (96041032000), PRODUCT NO. 960 41 03-20**  
**MOWER DECK 44**

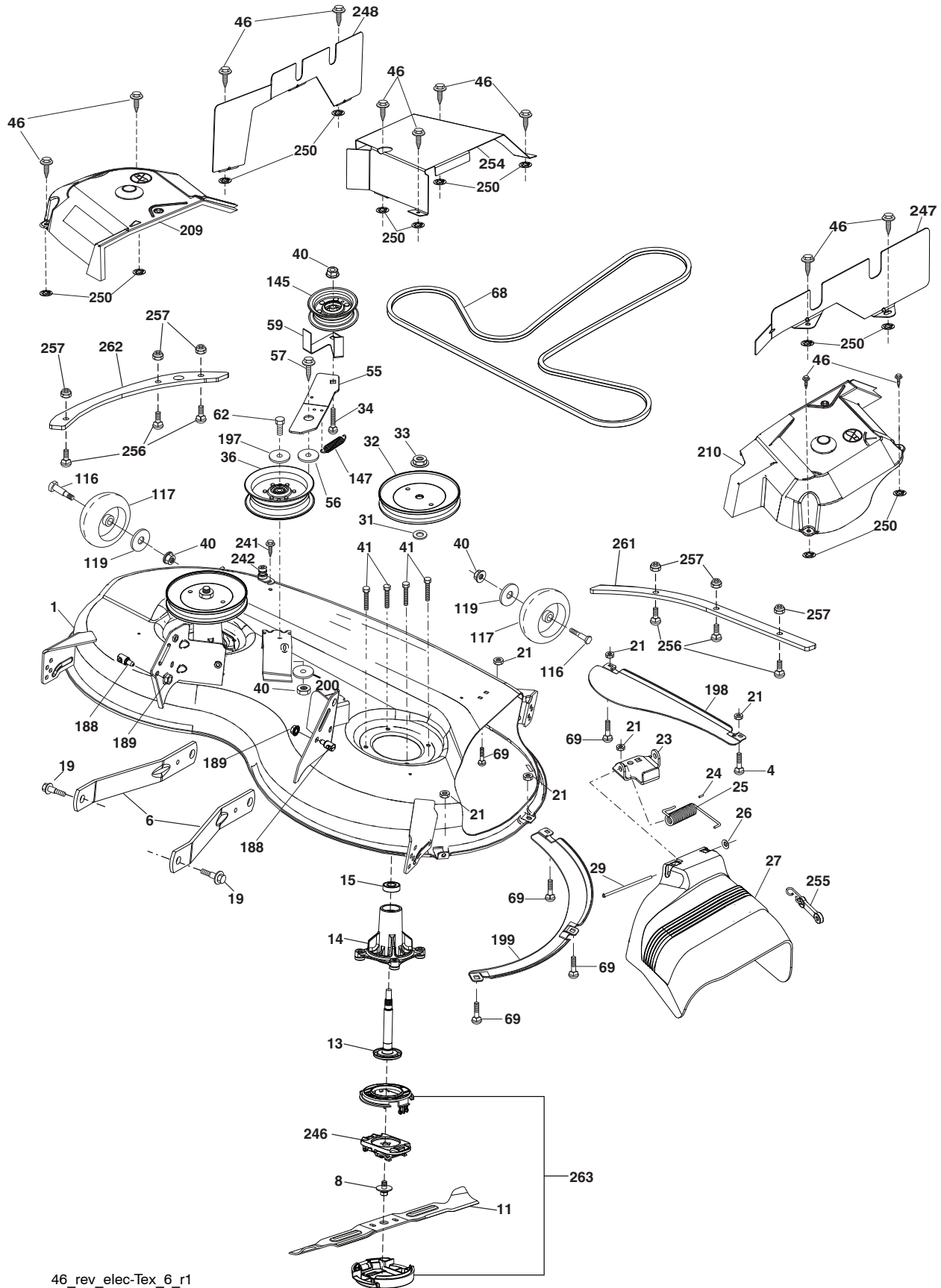

46\_rev\_elec-Tex\_6\_r1

**TRACTOR - - MODEL NO. YTH 224TFi (96041032000), PRODUCT NO. 960 41 03-20  
MOWER DECK 44**

KEY NO.	PART NO.	DESCRIPTION	KEY NO.	PART NO.	DESCRIPTION
1	583 90 09-02	Mower Housing	147	532 19 72-51	Spring Return
4	874 76 05-12	Bolt Hex Hd 5/16-18 unc	188	532 19 51-61	Stud Fastener
6	532 19 51-86	Arm Suspension	189	873 90 05-00	Nut Lock Hex Flange
8	584 30 93-01	Screw	197	819 13 13-12	Washer 13/32 x 13/16 x 12 Ga.
11	581 04 39-01	Blade Mower	198	532 40 31-49	Baffle Center Front
13	580 85 47-01	Shaft Asm. Rev. Tall	199	532 40 31-50	Baffle Front RH
14	580 79 61-01	Housing, Mandrel	200	532 41 35-24	Washer 13/32 x 1 x 1/2 11 Ga.
15	532 11 04-85	Bearing, Ball, Mandrel	209	532 43 23-95	Cover Asm Mandrel LH
19	532 19 65-39	Bolt, Shoulder	210	532 43 23-96	Cover Asm Mandrel RH
21	873 68 05-00	Nut	241	532 15 29-27	Screw
23	532 19 25-57	Bracket, Deflector	242	532 41 55-98	Washout Port
24	532 10 53-04	Cap, Sleeve	246	580 95 40-03	Blade Holder
25	532 19 70-26	Spring, Torsion, Deflector	247	532 43 23-98	Cover Asm Deck RH
26	532 11 04-52	Nut, Push	248	532 43 23-97	Cover Asm LH
27	532 44 28-95	Shield, Deflector	250	532 42 30-62	Palnut 1/4
29	532 13 14-91	Rod, Hinge	254	532 43 23-99	Cover Asm Rear
31	532 18 76-90	Washer, Spacer	255	532 43 60-87	Kit Bungee
32	532 19 74-73	Pulley, Mandrel	256	578 29 64-04	Screw Buttonhead 5/16-18
33	532 40 02-34	Nut, Toplock, Flanged	257	873 90 04-00	Nut Hex Flange 1/4-20 unc
34	872 11 06-12	Bolt Carr Sh. 3/8-16 x 1-1/2 Gr. 5	261	585 31 77-05	Plate Reinforcement Front
36	532 19 73-79	Pulley, Idler, Flat	262	585 31 78-05	Plate Reinforcement Side
40	873 90 06-00	Nut, Lock Flg. 3/8-16 unc	263	586 63 85-01	Upper/Lower Cap Asm.
41	584 95 39-01	Bolt Hex Washer Head 3/8-18 x 1.19	--	532 41 64-05	Coupling Quick Connect
46	532 13 77-29	Screw	--	580 85 60-01	Mandrel Assembly-Tall (Includes Housing (Key #14), Shaft Assembly (Key #13), and Bearing Only (Key #15) Pulley/Nut/Washer and Blade Bolt/Washers Not Included)
55	532 19 72-49	Arm, Idler			
56	532 19 90-92	Spacer, Retainer			
57	817 00 06-16	Screw Hexwsh Thd 3/8-16 x 1			
59	532 14 10-43	Guard, Tuv Idler (94)			
62	874 52 06-36	Bolt 3/8-16 unc x 2-1/4 Gr. 5	--	586 26 49-01	Replacement Mower, Complete
68	532 40 51-43	V-Belt			
69	872 14 05-05	Bolt			
116	532 19 34-06	Bolt, Shoulder			
117	532 17 48-73	Wheel, Gauge			
119	819 13 20-12	Washer 13/32 x 1-1/2 x 11 Ga.			
145	532 19 31-97	Pulley Idler			

**NOTE:** All component dimensions given in U.S. inches  
1 inch = 25.4 mm

**TRACTOR -- MODEL NO. YTH 224TFi (96041032000), PRODUCT NO. 960 41 03-20**  
**MOWER LIFT 45**

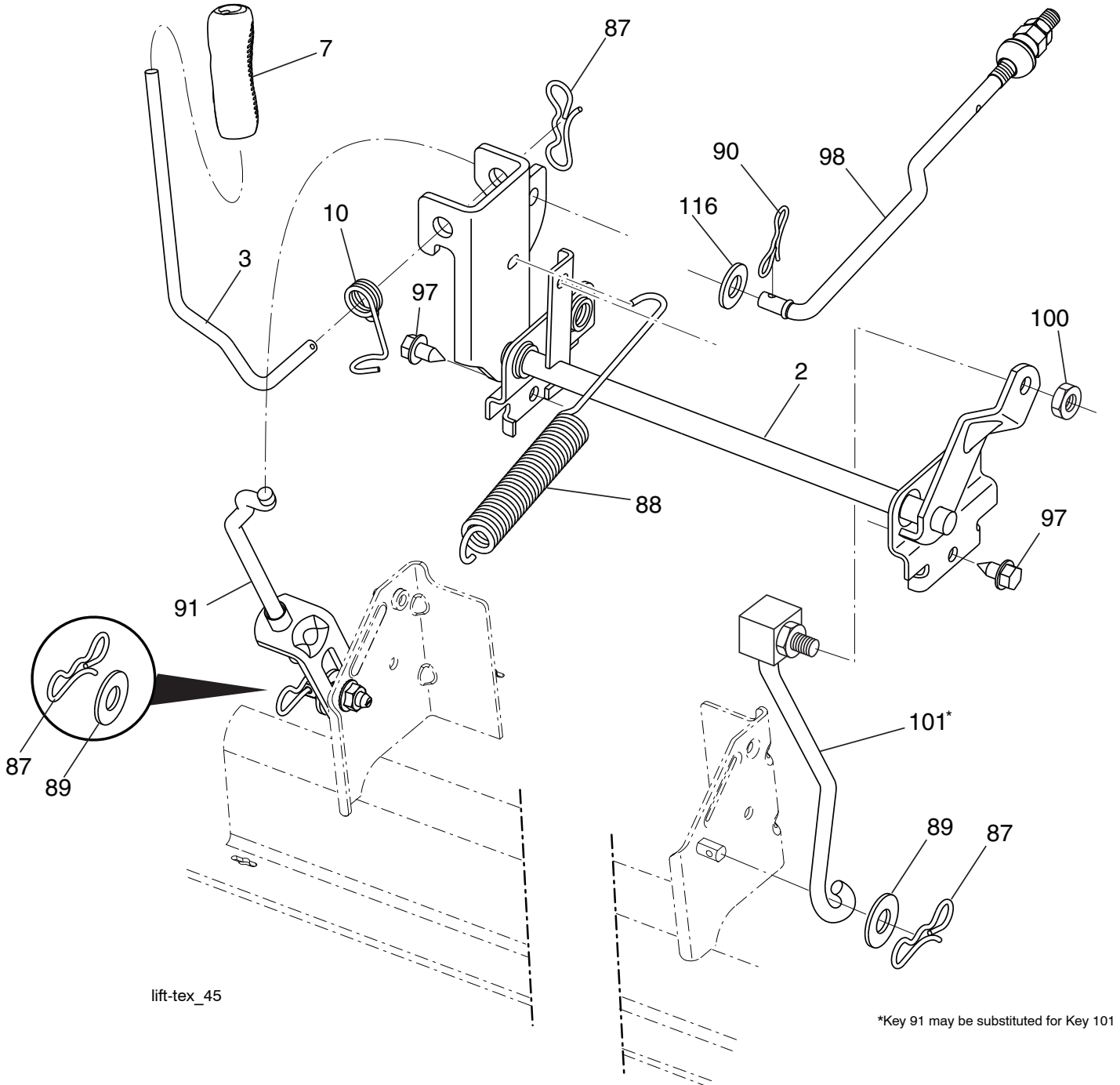

KEY NO.	PART NO.	DESCRIPTION
2	532 42 20-27	Shaft Asm., Lift
3	532 19 52-30	Lever Asm., Lift RH
7	580 96 23-01	Grip, Lever
10	532 19 63-14	Spring Torsion
87	532 19 42-09	Pin Cotter 7/16 Bow Tie Lock
88	532 41 07-10	Spring Lift Assist
89	819 19 19-12	Washer Clear Zinc
90	532 19 42-08	Pin Cotter 5/16 Bow Tie Lock
91	532 19 51-81	Lift Link Asm. Rear

KEY NO.	PART NO.	DESCRIPTION
97	817 00 06-12	Screw 3/8-16 x .75 Smgml. Tap/R.Z
98	532 19 52-70	Link Asm. Susp. Front Mower
100	873 93 06-00	Nut 3/8-16 unc
101	532 40 70-03	Link Asm. Lift Fixed
116	819 15 15-16	Washer 15/32 x 15/16 x 16 Ga.

**NOTE:** All component dimensions given in U.S. inches  
 1 inch = 25.4 mm



**TRACTOR - - MODEL NO. YTH 224TFi (96041032000), PRODUCT NO. 960 41 03-20  
SEAT ASSEMBLY 42**

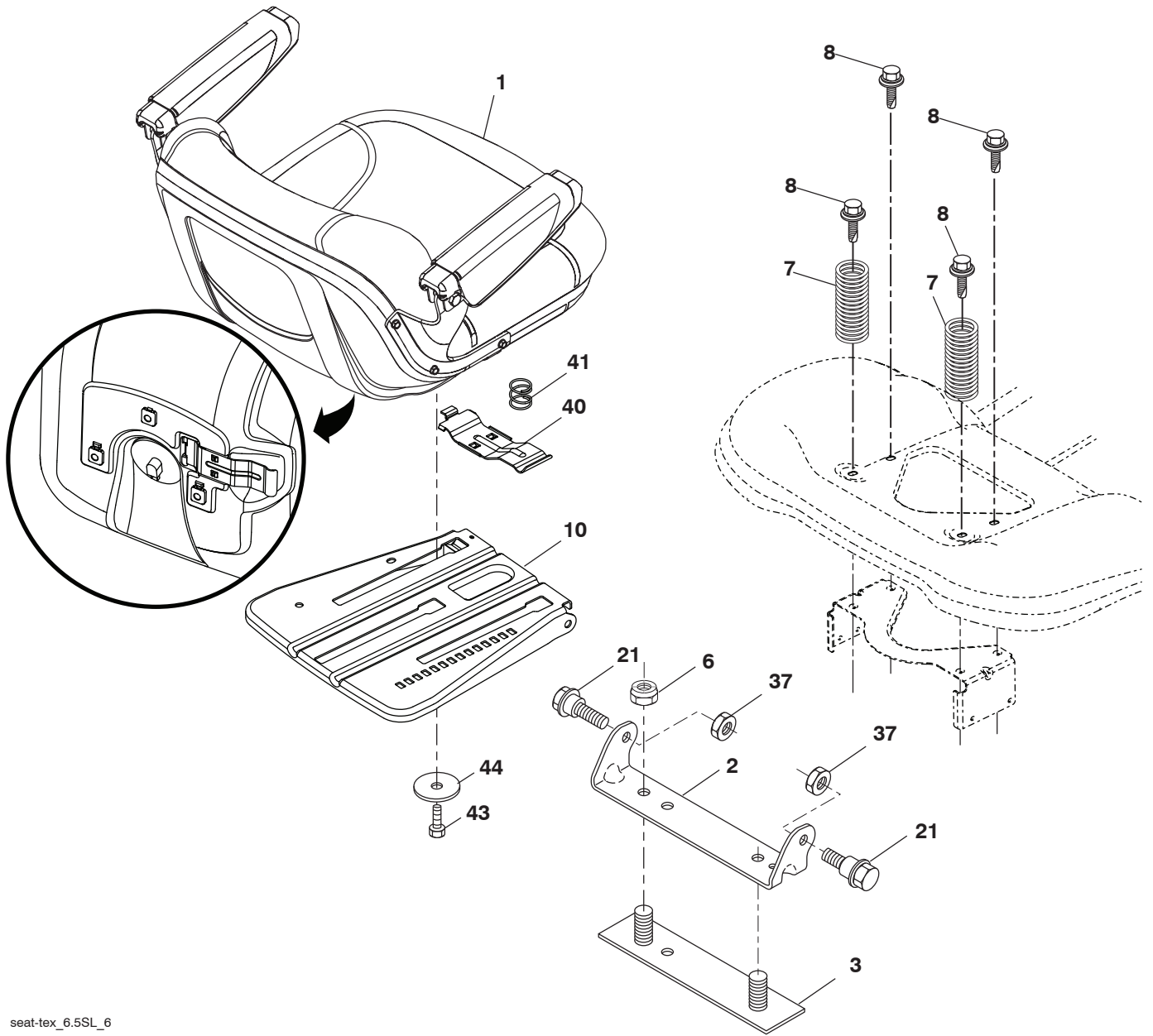

seat-tex\_6.5SL\_6

KEY NO.	PART NO.	DESCRIPTION
1	532 44 32-63	Seat
2	532 18 01-66	Bracket Pivot Fender
3	532 14 06-75	Strap, Asm Fender
6	873 80 06-00	Nut, Lock W/Ins. 3/8-16 unc
7	532 12 41-81	Spring, Seat Cprsn
8	532 17 18-77	Bolt 5/16-18 unc x 3/4 w/Sems
10	532 19 69-77	Pan, Seat
21	532 17 18-52	Bolt, Shoulder 5/16-18

KEY NO.	PART NO.	DESCRIPTION
37	873 80 05-00	Nut, Lock 5/16-18 unc
40	532 19 76-61	Handle Slide Seat
41	532 19 82-00	Spring Latch Seat
43	874 76 06-12	Bolt Fin Hex 3/8-16 unc x 3/4
44	819 13 38-12	Washer 13/32 x 2-3/8 x 12 Ga.

**NOTE:** All component dimensions given in U.S. inches  
1 inch = 25.4 mm

