

# ILLUSTRATED PARTS LIST

MODEL NO. 96041022101

CUSTOMER CATALOG NO. YTH2754T

PRODUCT NO. 960 41 02-21

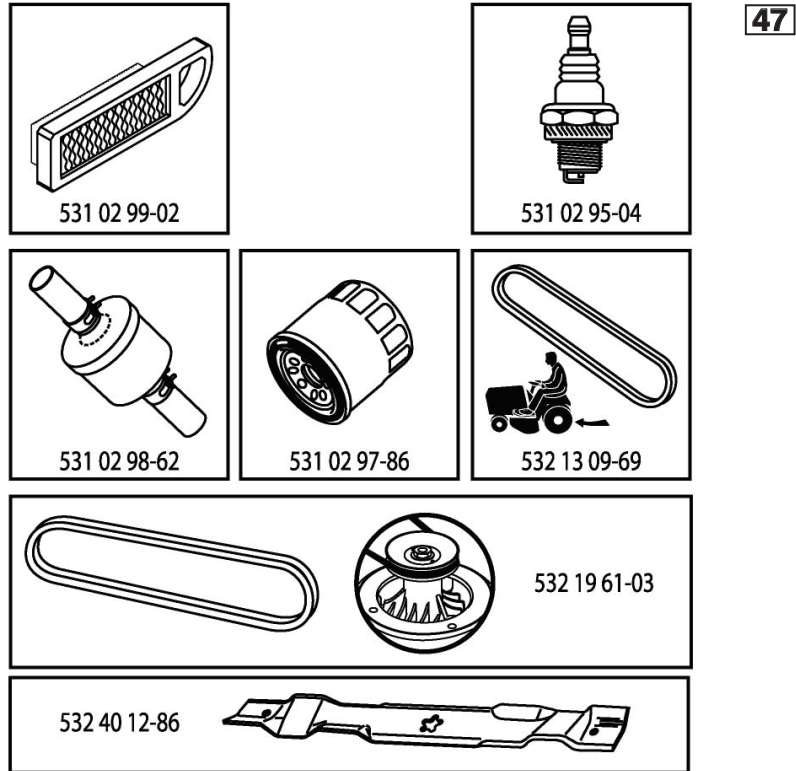

435341

**TRACTOR - MODEL NO. YTH2754T (96041022101), PRODUCT NO. 96041 02-21  
DECALS 27**

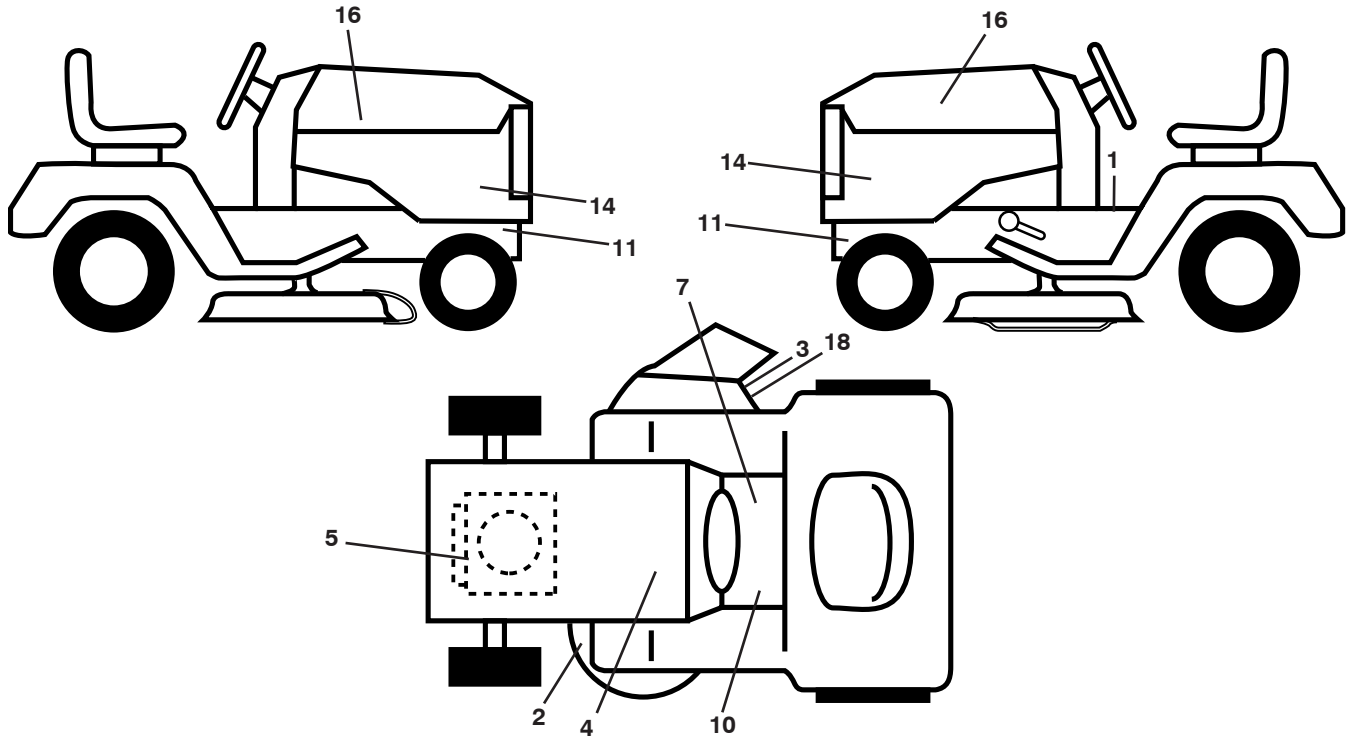

KEY NO.	PART NO.	DESCRIPTION	KEY NO.	PART NO.	DESCRIPTION
1	581 57 81-01	Decal, Operator's	16	581 62 73-01	Decal, Hood Logo
2	581 58 00-02	Decal, Mower Sch.	18	581 57 92-01	Decal, Deflector Warn
3	581 57 91-01	Decal, Warning	--	581 72 48-01	Decal, Bypass
4	532 14 50-05	Decal, Battery	--	581 72 46-01	Decal, Load Limit
5	581 57 97-01	Decal, Warning Engine Sym.	--	532 43 98-82	Pad, Footrest, LH
7	581 57 80-01	Decal, Warn Sym	--	532 43 98-81	Pad, Footrest, RH
10	581 72 40-01	Decal, Brake/Clutch	--	115 56 99-49	Manual, Operator's (Eng./Span.)
11	581 57 96-01	Decal, Hot Muffler	--	115 57 00-59	Manual, Operator's (Port.)
14	532 44 18-26	Decal, Side Panel			

**WHEELS AND TIRES**

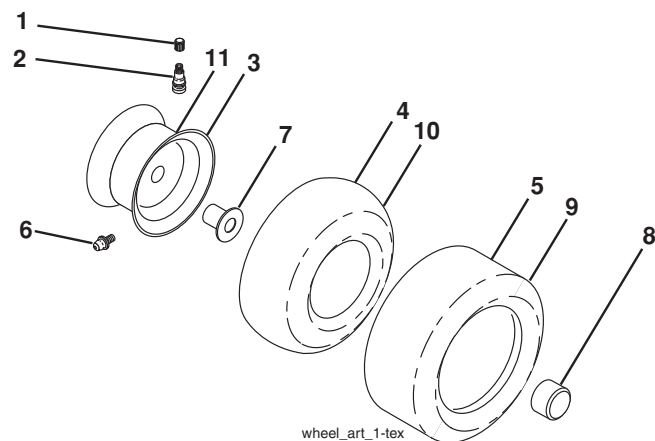

KEY NO.	PART NO.	DESCRIPTION
1	532 05 91-92	Cap, Valve, Tire
2	532 06 51-39	Stem, Valve
3	532 18 18-39	Rim Assembly, Front
4	532 00 81-34	Tube, Front (Service Item Only)
5	532 10 62-30	Tire, Front
6	532 12 49-57	Fitting, Grease (Front Wheel Only)
7	532 12 49-59	Bearing, Flange (Front Wheel Only)
8	532 17 50-39	Cap, Axle (Front Wheel Only)
9	532 18 47-08	Tire, Rear
10	532 00 71-54	Tube, Rear (Service Item Only)
11	532 40 17-82	Rim Assembly, Rear
--	532 14 43-34	Sealant, Tire (10 oz. Tube)

**NOTE:** All component dimensions given in U.S. inches  
1 inch = 25.4 mm

# TRACTOR - MODEL NO. YTH2754T (96041022101), PRODUCT NO. 960 41 02-21

## SCHEMATIC **38**

SCH12

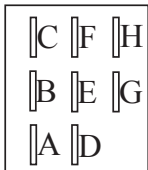
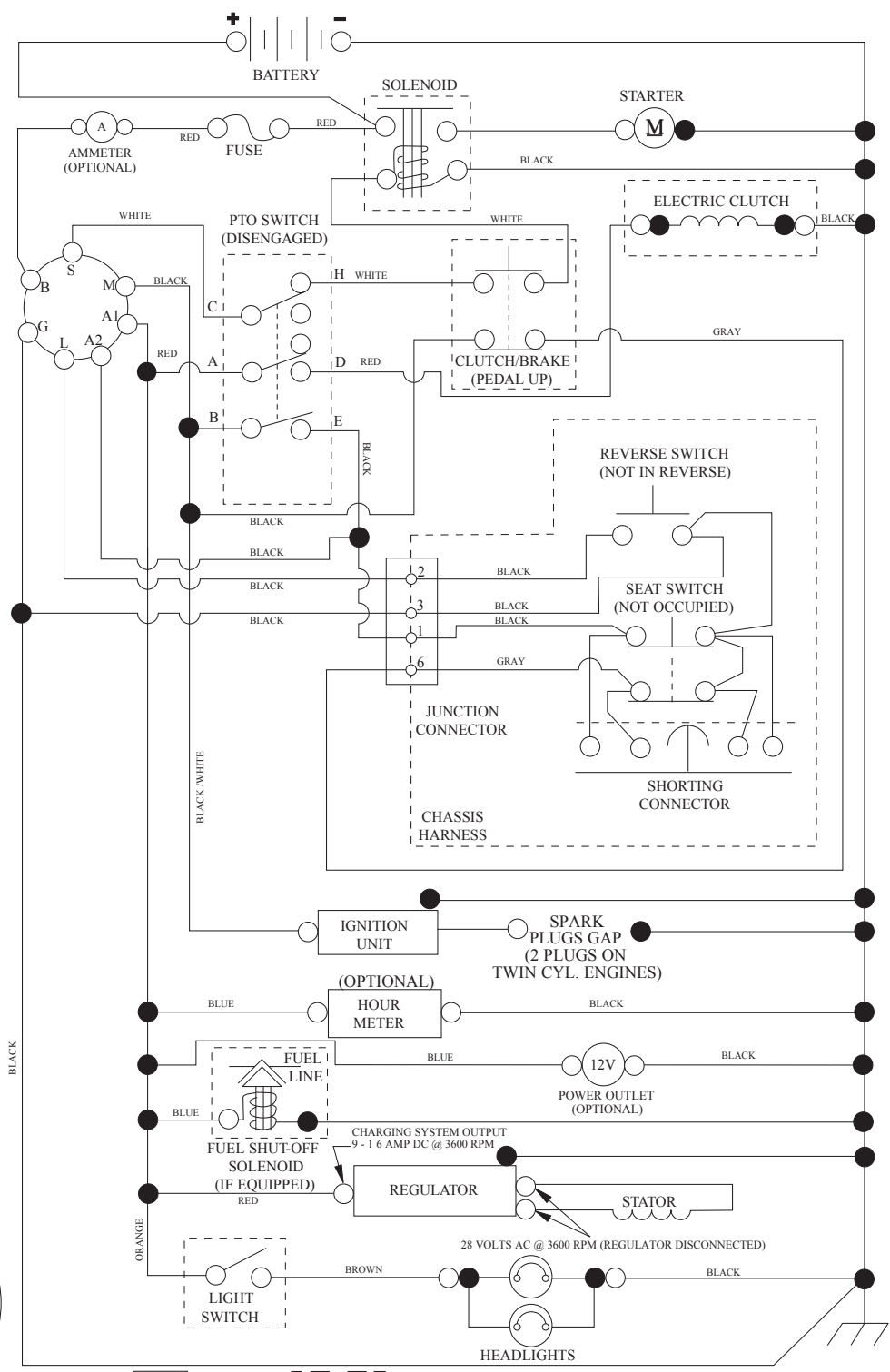

PTO SWITCH (MATING SIDE)

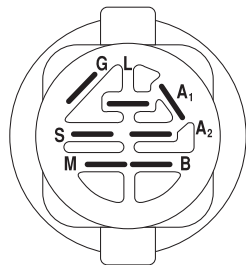

IGNITION SWITCH

POSITION	CIRCUIT "MAKE"
OFF	M+G+A1
RUN/OVERRIDE	B+A1
RUN	B+A1 L+A2
START	B + S + A1

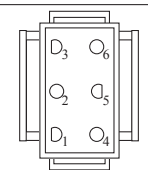

CHASSIS HARNESS CONNECTOR (MATING SIDE)

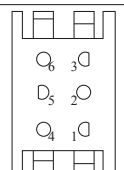

DASH HARNESS CONNECTOR

WIRING INSULATED CLIPS  
 NOTE: IF WIRING INSULATED CLIPS WERE REMOVED FOR SERVICING OF UNIT, THEY SHOULD BE RE-INSTALLED TO PROPERLY SECURE YOUR WIRING.

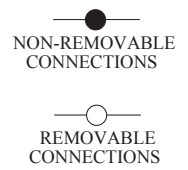

**TRACTOR - MODEL NO. YTH2754T (96041022101), PRODUCT NO. 96041 02-21**  
**ELECTRICAL 32**

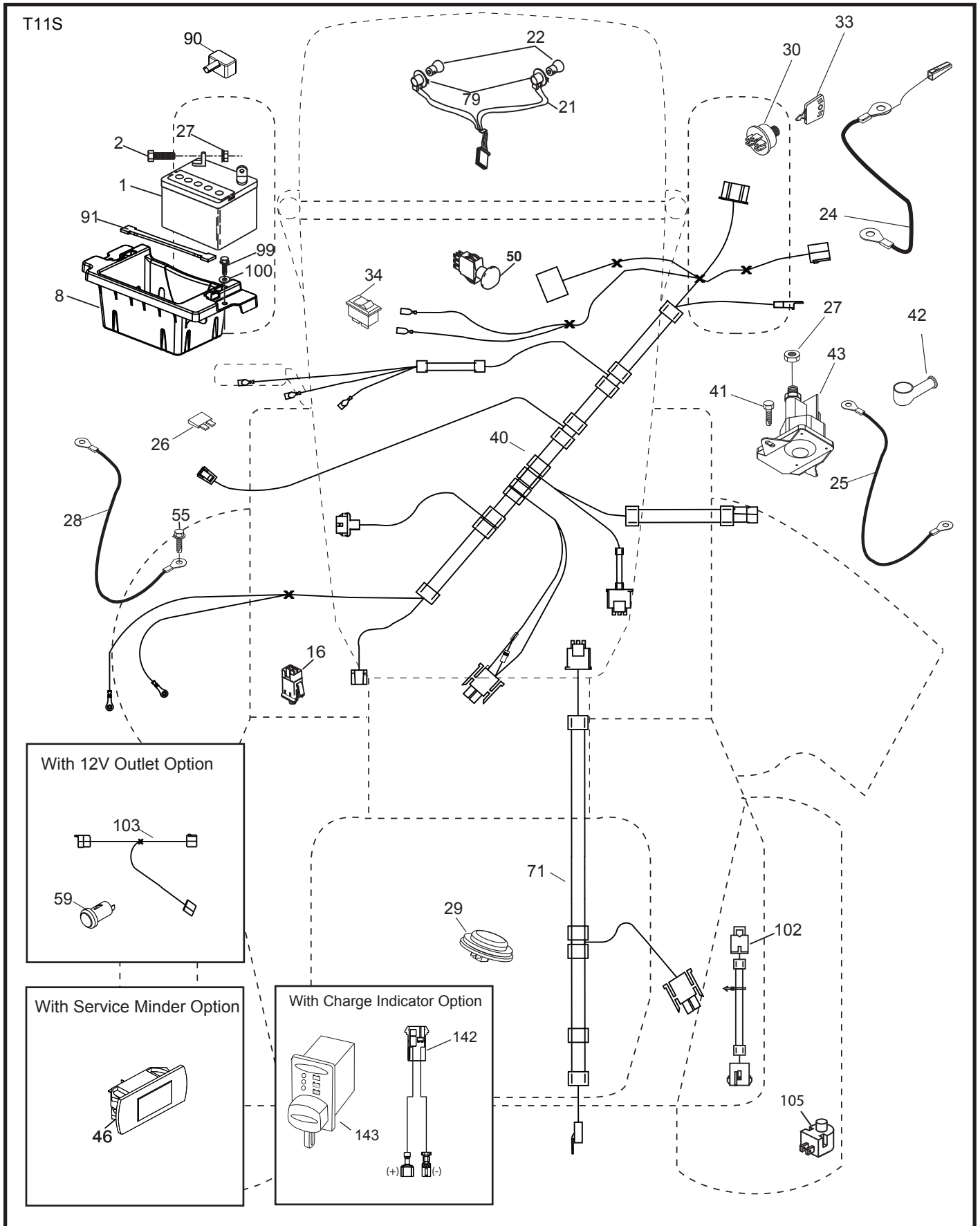

**TRACTOR - MODEL NO. YTH2754T (96041022101), PRODUCT NO. 96041 02-21  
ELECTRICAL 32**

<b>KEY NO.</b>	<b>PART NO.</b>	<b>DESCRIPTION</b>
1	532 16 34-65	Battery
2	874 76 04-12	Bolt Hex Hd 1/4-20 unc x 3/4
8	532 18 64-91	Battery Box
16	532 17 61-38	Switch Interlock
21	532 40 02-52	Harness Socket Light
22	532 00 41-52	Bulb, Light #1156
24	532 40 02-53	Cable Battery
25	585 55 55-01	Cable Starter
26	532 17 51-58	Fuse
27	873 51 04-00	Nut Keps Hex 1/4-20 unc
28	532 14 54-91	Cable Ground 21" Blk 6 Ga.
29	532 40 15-45	Switch Seat
30	532 19 33-50	Switch Ign
33	532 41 19-33	Key/Chain
34	532 11 07-12	Switch Light/Reset
40	532 40 11-04	Harness Ign. Dash
41	817 72 04-08	Screw Thd Cut 1/4-20 x 1/2
42	532 13 15-63	Cover Terminal Red
43	532 19 25-07	Solenoid
46	532 40 17-63	Gauge Hourmeter
50	532 17 46-51	Switch PTO
55	817 06 05-12	Screw Thdrol 5/16-18 x 3/4
71	532 19 42-76	Harness Ign Chassis
79	532 17 52-42	Socket Asm. Bulb Twistlock
90	532 43 53-95	Cover Terminal Battery
91	532 19 02-70	Strap Battery
99	817 67 04-12	Screw Hexwsh Thdrol 1/4-20 x 3/4
100	819 09 14-16	Washer 9/32 x 7/8 x 16 Ga.
102	532 40 44-54	Harness Pigtail K46 Tex ROS
105	532 40 75-68	Switch Reverse TT Pedal Control

**NOTE:** All component dimensions given in U.S. inches  
1 inch = 25.4 mm

TRACTOR - MODEL NO. YTH2754T (96041022101), PRODUCT NO. 96041 02-21  
CHASSIS AND ENCLOSURES **39**

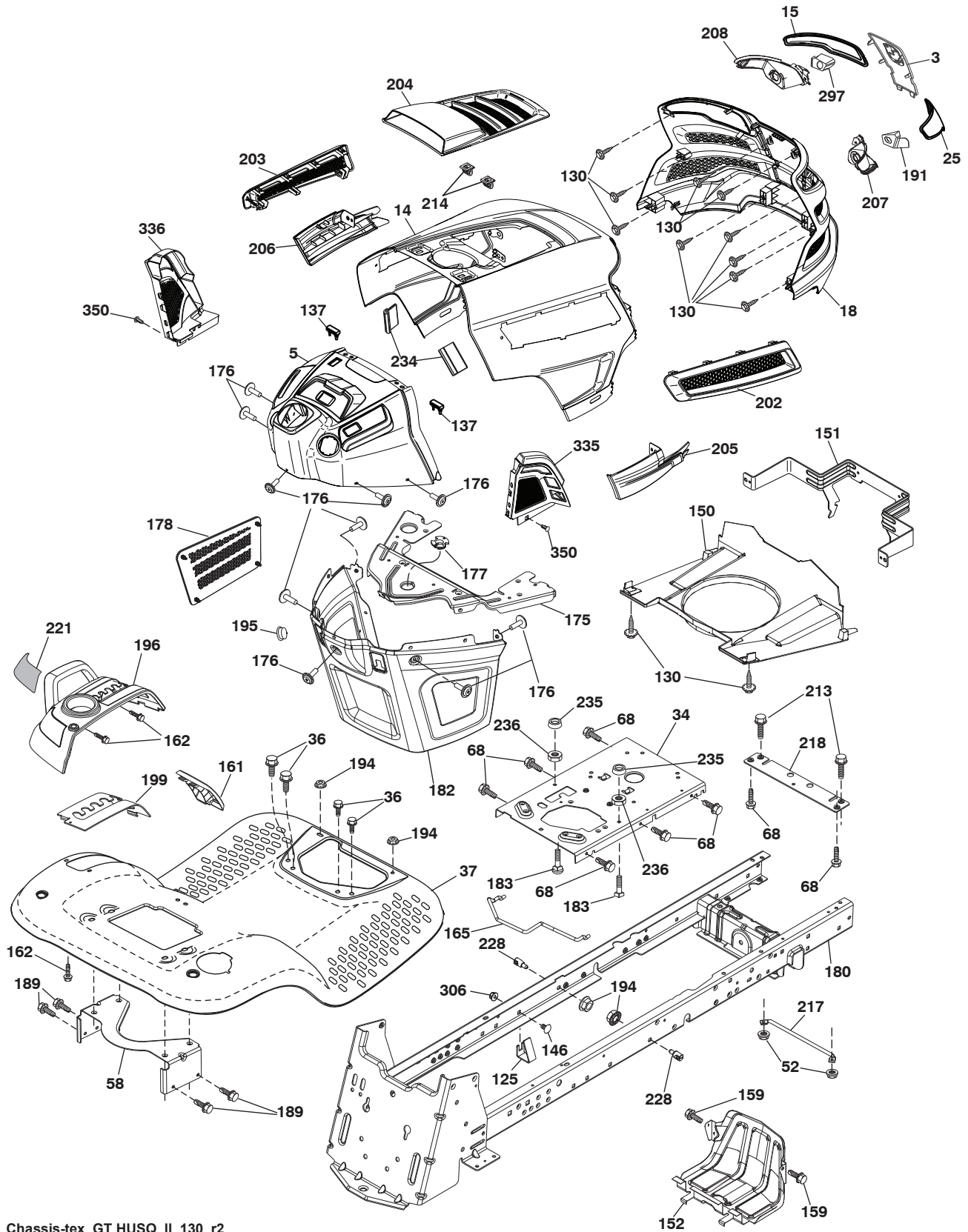

Chassis-tex\_GT HUSQ\_II\_130\_r2

**TRACTOR - MODEL NO. YTH2754T (96041022101), PRODUCT NO. 960 41 02-21  
CHASSIS AND ENCLOSURES 39**

KEY NO.	PART NO.	DESCRIPTION	KEY NO.	PART NO.	DESCRIPTION
3	532 43 97-52	Applique	191	532 43 74-55	Insert Reflective RH
5	532 43 74-80	Dash	194	873 90 05-00	Nut Lock 5/16-18
14	532 44 11-77	Hood	195	532 40 41-37	Plug Hole Dash
15	532 43 97-33	Lens LH	196	532 43 97-16	Console Asm. Deck Lift
18	532 44 06-53	Grille	199	532 19 82-59	Plate Deck Lift
25	532 44 33-85	Lens RH	202	532 43 97-28	Vent Side Hood RH
34	580 91 08-01	Plate Engine	203	532 43 97-27	Vent Side Hood LH
36	817 06 05-12	Screw 5/16-18 x 3/4	204	532 43 57-14	Vent Top
37	532 44 12-08	Fender	205	532 43 97-30	Hood Side RH Trim
52	873 68-05-00	Nut Crown Lock 5/16-18	206	532 43 97-29	Hood Side LH Trim
58	532 19 43-14	Bracket Fender	207	532 43 97-34	Bezel RH
68	817 49 05-08	Screw 5/16-18 x 1/2	208	532 43 97-35	Bezel LH
125	581 68 48-01	Clip Fuel Line	213	874 76 05-12	Bolt Hex Hd 5/16-18 unc x 3/4
130	532 41 63-58	Screw #10 x 0.750 BOS Thread	214	532 19 91-45	Clip Retainer
137	532 40 75-90	Bumper Dash	217	532 40 91-67	Rod Pivot
146	581 85 79-01	Bolt	218	532 19 63-95	Hood Stop
150	532 43 97-74	Duct Heat Hood	221	532 19 89-09	Reflector LH
151	532 43 66-70	Bracket Pivot	228	532 19 51-61	Stud Fastener
152	532 43 98-70	Shield Browning/Debris	234	532 40 47-42	Bumper Hood
159	817 00 06-12	Screw 3/8-16 x 3/4	235	532 40 61-29	Spacer Fender
161	532 43 99-29	Console Fuel Window	236	873 93 05-00	Nut Center Lock 5/16-18 unc
162	532 14 24-32	Screw Hex Wsh Hi-Lo 1/4 x 1/2	297	532 43 74-56	Insert Reflective LH
165	532 19 68-26	Bracket Support Tank	306	873 90 06-00	Nut
175	532 19 63-04	Crossmember	335	532 44 53-09	Cover Lower Dash LH
176	532 40 07-76	Screw 10-24 x 5/8 Wshd Qdrx	336	532 44 82-04	Cover Lower Dash RH
177	532 19 52-27	Bushing Steering	350	532 44 51-43	Clip
178	532 19 97-82	Cargo Asm. Net			
180	532 19 54-77	Chassis			
182	532 40 68-59	Dash Lower			
183	874 52 05-20	Bolt 5/16-18 x 1-1/4			
189	817 00 05-12	Screw 5/16-18 x 3/4			

**NOTE:** All component dimensions given in U.S. inches  
1 inch = 25.4 mm

TRACTOR - MODEL NO. YTH2754T (96041022101), PRODUCT NO. 96041 02-21  
DRIVE **40**

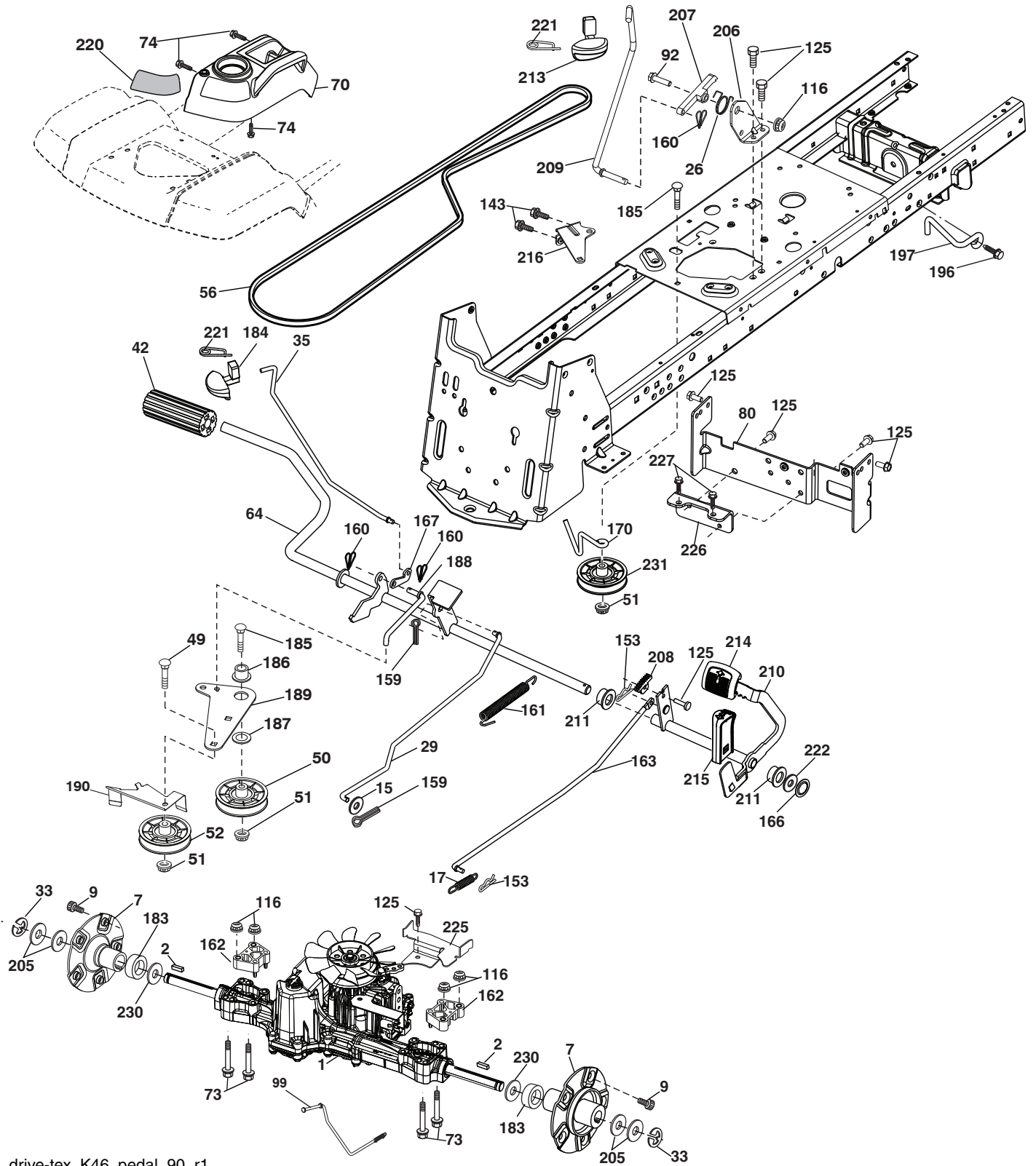

drive-tex\_K46\_pedal\_90\_r1



**TRACTOR - MODEL NO. YTH2754T (96041022101), PRODUCT NO. 960 41 02-21  
DRIVE **40****

KEY NO.	PART NO.	DESCRIPTION	KEY NO.	PART NO.	DESCRIPTION
1	-----	Transaxle, TUFFTORQ K46 BN (426119) (Order parts from trans-axle manufacturer.)	167	532 40 52-57	Latch Brake Parking
2	532 18 62-11	Key	170	532 41 34-30	Keeper Belt Centerspan
7	532 19 98-44	Hub Asm. Wheel	183	532 40 04-24	Spacer Split
9	532 14 00-80	Bolt Hub Wheel	184	532 44 14-55	Handle Parking Brake
15	819 13 13-16	Washer 13/32 x 13/16 x 16 Ga.	185	872 11 06-22	Bolt Rdhd Sqnk 3/8-16 x 2-3/4
17	532 41 36-78	Spring, Brake	186	532 19 43-21	Spacer Retainer
26	532 19 96-79	Spring Return Cruise	187	819 13 32-10	Washer
29	532 40 38-06	Rod, Brake	188	532 19 43-23	Link Clutch Ground Drive
33	812 00 00-01	Ring E	189	532 19 43-17	Bellcrank Ground Drive
35	583 86 45-01	Rod, Brake, Park	190	532 19 43-18	Keeper Bellcrank Ground Drive
42	532 12 48-72	Cover, Foot Pedal	196	817 00 06-16	Screw 3/8-16 x 1
49	872 11 06-14	Bolt	197	585 65 86-01	Bracket Clutch Anti-Rotation
50	532 19 43-27	Pulley Idler Flat	205	532 12 17-48	Washer
51	873 90 06-00	Lock Nut 3/8-16	206	532 44 85-96	Bracket Mount Latch Cruise
52	532 19 43-26	Idler V-Groove 910" Offset	207	532 19 78-68	Latch Control Cruise
56	532 13 09-69	V-Belt, Drive	208	532 19 78-69	Gear Sector Control Cruise
64	532 19 78-65	Shaft Asm. Pedal Brake Control	209	532 19 95-92	Rod Control Cruise
70	532 43 96-61	Console Asm.	210	532 19 78-60	Rocker Asm. Pedal Control
73	874 49 05-60	Bolt Hex Flngd 5/16-18 x 3.75	211	532 12 01-83	Bearing Nylon
74	532 14 24-32	Screw 1/4 x 1/2	213	532 40 31-19	Knob Control Cruise
80	532 44 06-19	Strap Torque	214	532 42 12-63	Pedal Forward
92	874 76 05-20	Bolt Fin Hex 5/16-18 unc x 1.25	215	532 40 17-23	Pedal Reverse
99	532 41 57-43	Rod Spring Bypass	216	532 19 61-31	Bracket Pulley Idler
116	873 90 05-00	Nut Lock Hex Flange 5/16-18	220	532 19 89-08	Reflector RH
125	817 00 05-12	Screw 5/16-18 x 3/4	221	532 40 31-87	Retainer Spring Clip Handle
143	817 49 05-08	Screw Thdrol 5/16-18 x 1/2	222	879 21 20-10	Washer 21/32 x 1-1/4 x 10 Ga.
153	532 12 47-88	Retainer Spring	225	532 40 33-19	Keeper Belt Trans.
159	876 02 04-12	Pin Cotter 1/8 x 3/4	226	532 40 08-31	Bracket Mount Torque
160	532 16 94-84	Retainer Clip	227	817 49 05-12	Screw 5/16-18 x 3/4
161	532 10 57-09	Spring, Return, Clutch	230	532 18 89-67	Washer
162	580 45 74-01	Spacer Transaxle	231	532 40 72-87	Idler V-Groove
163	532 44 82-75	Rod Pedal Control			
166	532 42 91-64	Nut Push .625			

**NOTE:** All component dimensions given in U.S. inches  
1 inch = 25.4 mm

TRACTOR - MODEL NO. YTH2754T (96041022101), PRODUCT NO. 96041 02-21  
ENGINE 24

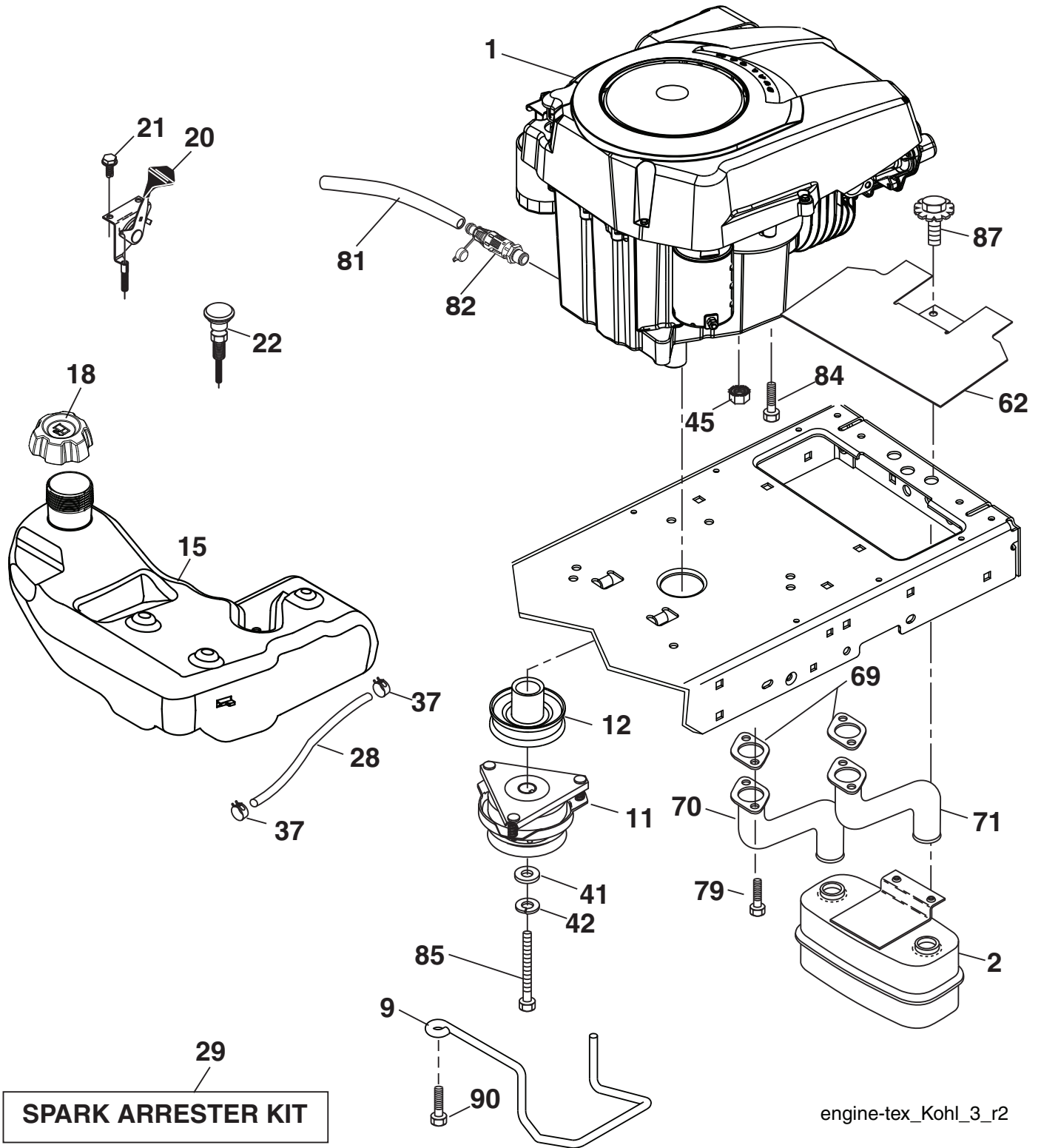

engine-tex\_Kohl\_3\_r2

**TRACTOR - MODEL NO. YTH2754T (96041022101), PRODUCT NO. 960 41 02-21  
ENGINE 24**

KEY NO.	PART NO.	DESCRIPTION
1	-----	Engine KOHL Model No. SV740-3019 (438342) (Order parts from engine manufacturer.)
2	532 14 97-23	Muffler
9	532 19 43-20	Keeper Belt Engine
11	587 24 14-01	Clutch Electric
12	532 19 43-43	Pulley Engine
15	532 19 34-99	Tank Fuel 4.0
18	532 43 96-45	Cap
20	532 18 29-37	Control Throttle
21	532 41 63-58	Screw #10 x 0.750 BOS Thread
22	532 19 15-96	Control Choke
28	532 14 21-58	Fuel Line
29	532 13 71-80	Spark Arrester Kit
37	532 12 34-87	Clamp Hose
41	532 12 61-97	Washer 1-1/2 OD x 15/32 ID x .250
42	810 04 07-00	Washer Lock 7/16
45	873 51 04-00	Nut Keps Hex 1/4-20 unc
62	532 43 40-17	Shield Heat Muffler
69	532 18 60-54	Gasket
70	532 14 66-99	Tube Exhaust LH
71	532 14 67-00	Tube Exhaust RH
79	532 19 23-34	Screw Socket Hd. 5/16-18 x .75
81	532 14 84-56	Tube Drain Oil Easy
82	532 42 82-87	Valve Oil Drain
84	817 12 06-16	Screw 3/8-16 x 1
85	581 63 62-01	Bolt Hex 7/16-20 x 3.0 x Gr. 5
87	532 19 82-39	Bolt 5/16-18 unc x 1 w/Sems
90	817 00 06-16	Screw 3/8-16 x 1

**NOTE:** All component dimensions given in U.S. inches  
1 inch = 25.4 mm

**TRACTOR - MODEL NO. YTH2754T (96041022101), PRODUCT NO. 96041 02-21**  
**STEERING ASSEMBLY 41**

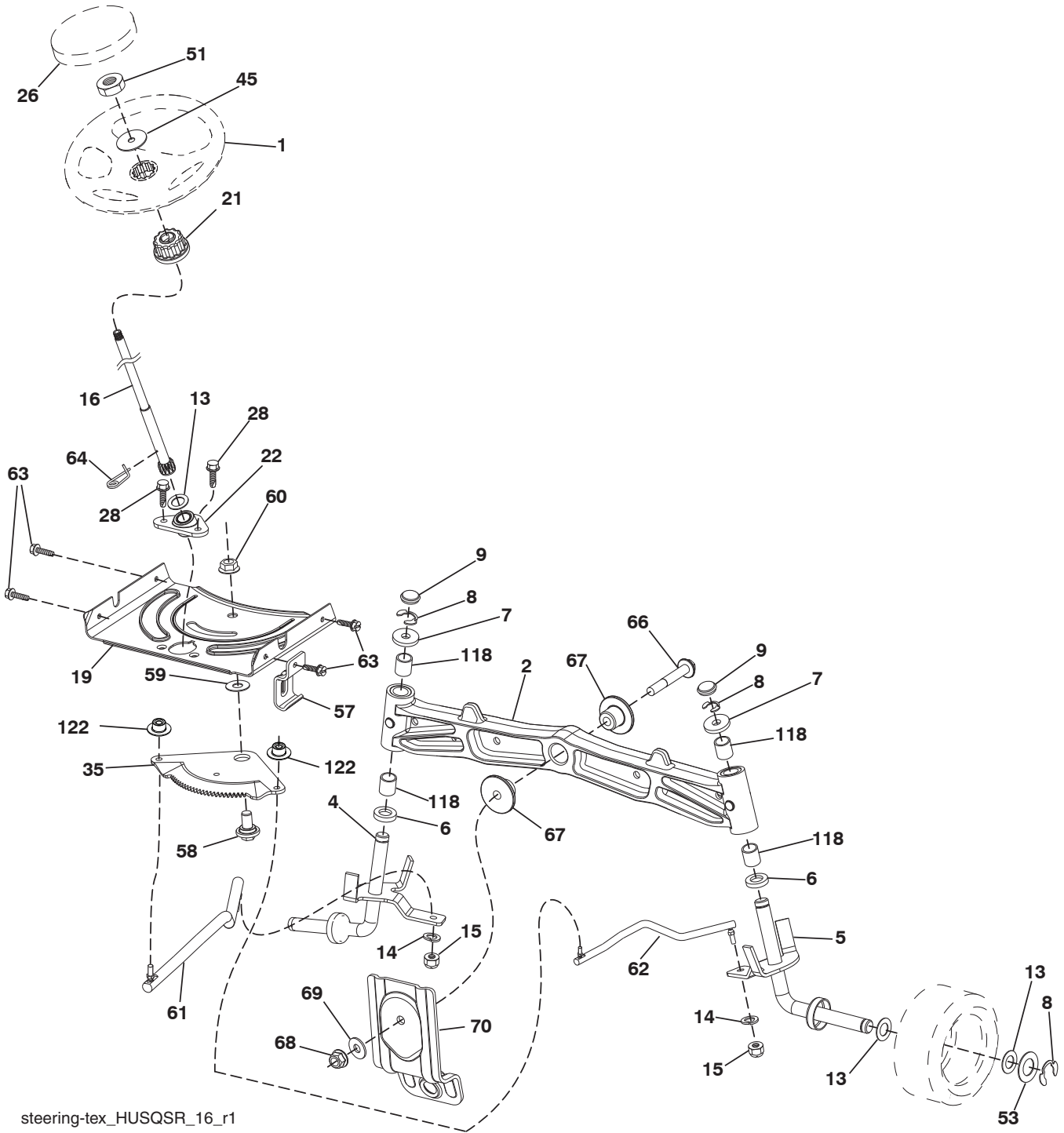

steering-tex\_HUSQSR\_16\_r1

**TRACTOR - MODEL NO. YTH2754T (96041022101), PRODUCT NO. 9604102-21**  
**STEERING ASSEMBLY 41**

<b>KEY NO.</b>	<b>PART NO.</b>	<b>DESCRIPTION</b>
1	532 43 97-40	Wheel, Steering
2	532 41 35-91	Axle Asm., Front
4	532 40 30-89	Spindle Asm., LH
5	532 40 30-90	Spindle Asm., RH
6	532 12 49-31	Bearing, Race Thrust Harden
7	532 12 17-48	Washer 25/32 x 1-5/8 x 16 Ga.
8	812 00 00-29	Ring, Klip #T5304-75
9	532 12 12-32	Cap, Spindle
13	532 12 17-49	Washer 25/32 x 1-1/4 x 16 Ga.
14	810 04 06-00	Washer, Lock Hvy Hlcl Spr 3/8
15	873 54 06-00	Nut, Crown Lock 3/8-24 unf
16	532 19 47-46	Shaft Steering
19	532 19 47-29	Plate Steering
21	532 18 67-37	Adapter, Wheel Steering
22	532 42 05-37	Steering Support Lower
26	532 43 97-43	Insert, Wheel Steering
28	817 00 06-12	Screw 3/8-16 x 3/4
35	532 19 47-32	Gear, Sector Plate
45	819 18 38-12	Washer 9/16 x 2-3/8 x 12 Ga.
51	873 94 08-00	Nut Hex Jam Toplock 1/2-20 unf
53	532 18 89-67	Washer Hardened .793 x 1.637 x .060
57	532 19 72-46	Bracket Upstop
58	532 19 47-47	Bolt Shoulder Sector Pivot CFM
59	532 19 47-48	Washer Thrust Sector Steering
60	873 97 10-00	Nut Flange Lock 5/8-11
61	532 19 47-40	Draglink, LH
62	532 19 47-41	Draglink, RH
63	817 00 05-12	Screw 5/16-18 x 3/4
64	532 19 98-49	Retainer Clip Spring Steering
66	871 02 07-48	Bolt Hex Fghd 7/16-14 x 3 Serr
67	532 19 47-37	Bushing PM Front Axle
68	873 90 07-00	Nut Lock Flange 7/16-14 Gr. 5
69	532 19 91-62	Washer 1.5 x .505 x .118
70	532 19 61-97	Bracket Deck Susp. Front
118	532 40 60-13	Bushing
122	532 44 49-62	Cap Gear Sector

**NOTE:** All component dimensions given in U.S. inches  
1 inch = 25.4 mm

TRACTOR - MODEL NO. YTH2754T (96041022101), PRODUCT NO. 96041 02-21  
MOWER DECK 44

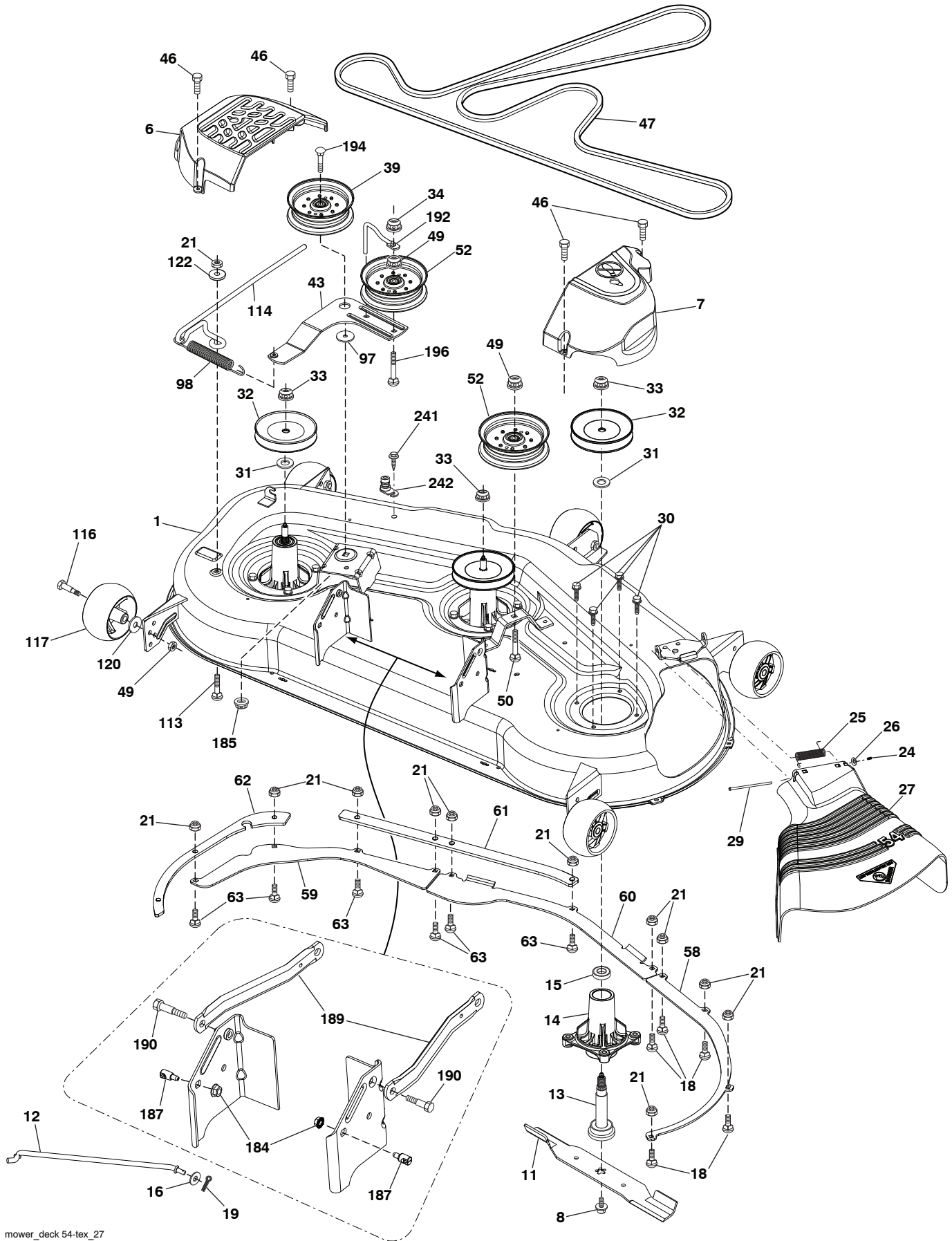

mower\_deck 54-tex\_27

**TRACTOR - MODEL NO. YTH2754T (96041022101), PRODUCT NO. 960 41 02-21  
MOWER DECK 44**

KEY PART NO. NO.	DESCRIPTION	KEY PART NO. NO.	DESCRIPTION
1	532 44 15-47	61	581 96 81-03
6	532 19 60-66	62	581 96 82-03
7	532 19 71-81	63	872 11 05-10
8	532 19 30-03	97	532 17 85-15
11	532 18 72-56	98	532 19 61-05
12	532 40 48-51	113	872 11 05-08
13	532 18 72-91	114	532 18 75-56
14	532 18 72-81	116	532 19 34-06
16	819 13 13-12	117	532 17 48-73
15	532 11 04-85	120	819 13 20-12
18	872 14 05-05	122	532 18 75-57
19	532 19 42-08	184	873 90 05-00
21	873 68 05-00	185	873 90 07-00
24	532 10 53-04	187	532 19 51-61
25	532 17 81-02	189	532 19 51-85
26	532 11 04-52	190	532 19 65-39
27	532 18 89-38	192	532 19 84-68
29	532 13 14-91	194	874 49 07-36
30	532 17 39-84	196	872 14 06-20
31	532 18 76-90	241	532 15 29-27
32	532 15 35-35	242	532 41 55-98
33	532 40 02-34	--	532 18 72-92
34	873 68 06-00		
39	532 19 73-80		
43	532 19 60-65		
46	532 13 77-29		
47	532 19 61-03		
49	873 90 06-00	--	584 30 45-01
50	872 11 06-16		
52	532 19 73-79		
58	532 18 73-42		
59	532 18 73-44		
60	532 18 76-07		

**NOTE:** All component dimensions given in U.S. inches  
1 inch = 25.4 mm

**TRACTOR - MODEL NO. YTH2754T (96041022101), PRODUCT NO. 96041 02-21**  
**MOWER LIFT 45**

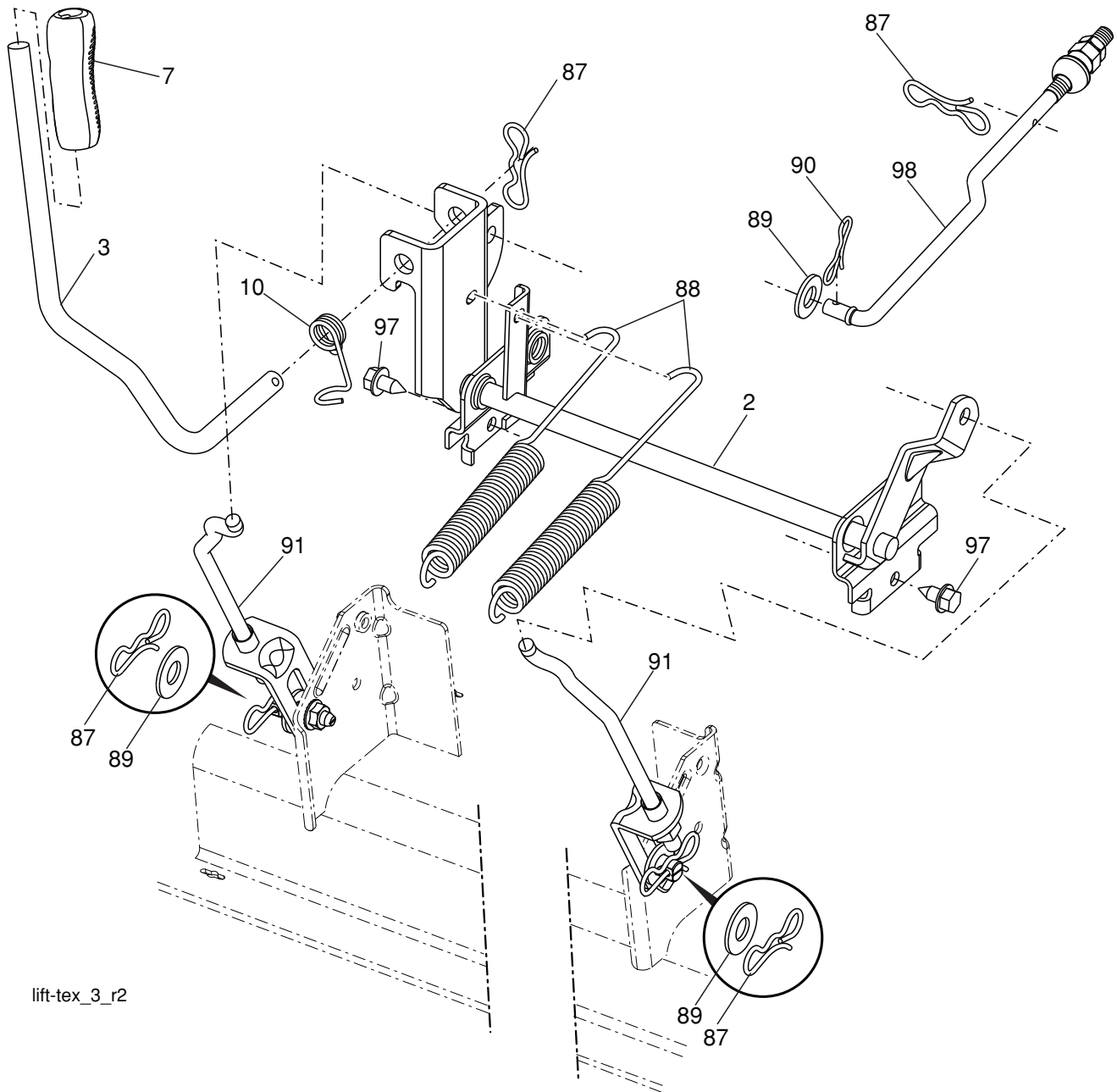

lift-tex\_3\_r2

KEY NO.	PART NO.	DESCRIPTION
2	532 42 20-27	Shaft Asm., Lift
3	532 19 52-30	Lever Asm., Lift RH
7	580 96 23-01	Grip, Lever
10	532 19 63-14	Spring Torsion
87	532 19 42-09	Pin Cotter 7/16 Bow Tie Lock
88	532 19 53-04	Spring Lift Assist
89	819 19 19-12	Washer 17/32 x 1-3/16 x 12 Ga.
90	532 19 42-08	Pin Cotter 5/16 Bow Tie Lock

KEY NO.	PART NO.	DESCRIPTION
91	532 40 34-07	Link Lift Susp Mower Rear
97	817 00 06-12	Screw 3/8-16 x .75
98	532 19 52-64	Link Lift Susp. Front Mower

**NOTE:** All component dimensions given in U.S. inches  
 1 inch = 25.4 mm



**TRACTOR - MODEL NO. YTH2754T (96041022101), PRODUCT NO. 9604102-21  
SEAT ASSEMBLY 42**

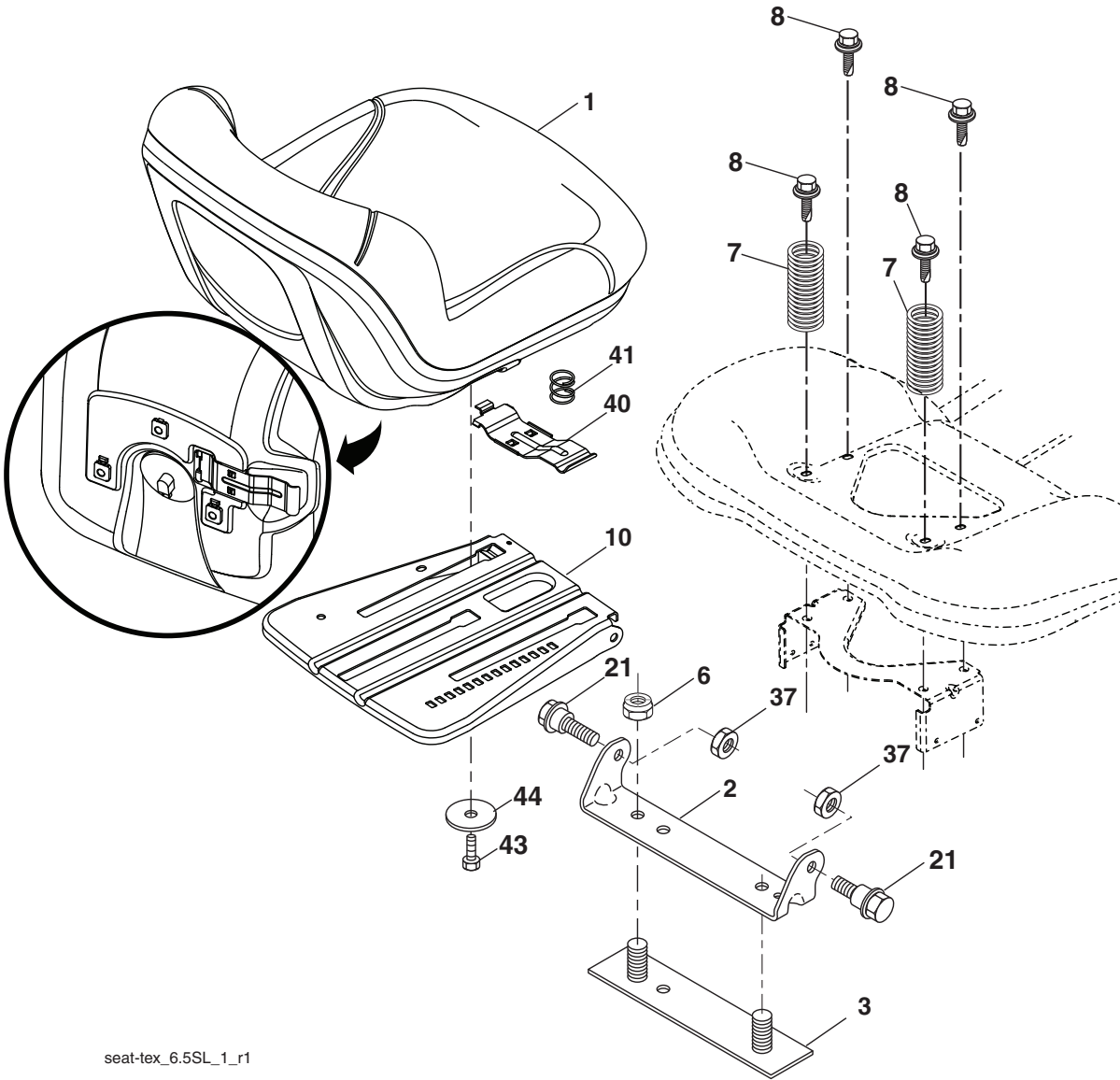

seat-tex\_6.5SL\_1\_r1

KEY NO.	PART NO.	DESCRIPTION
1	532 43 98-22	Seat
2	532 18 01-66	Bracket Pivot Fender
3	532 14 06-75	Strap, Asm Fender
6	873 80 06-00	Nut, Lock w/Ins. 3/8-16 unc
7	532 12 41-81	Spring, Seat Cprsn
8	532 17 18-77	Bolt 5/16-18 unc x 3/4 w/Sems
10	532 19 69-77	Pan, Seat
21	532 17 18-52	Bolt, Shoulder 5/16-18

KEY NO.	PART NO.	DESCRIPTION
37	873 80 05-00	Nut, Lock 5/16-18 unc
40	532 19 76-61	Handle Slide Seat
41	532 19 82-00	Spring Latch Seat
43	874 76 06-12	Bolt 3/8-16 x 3/4
44	819 13 38-12	Washer 13/32 x 2-3/8 x 12 Ga.

**NOTE:** All component dimensions given in U.S. inches  
1 inch = 25.4 mm

