

Repair Parts Manual

YTH2648TDRF / 96041026401/02



English

532 44 83-72 Rev. 27  

Please read the operator's manual carefully and make sure you understand the instructions before using the machine.

HOW TO USE THIS MANUAL

This manual is designed to provide the customer with a means to identify the parts on his/her tractor when ordering repair parts. The illustrations may or may not represent the actual assemblies; therefore, it is not recommended to use this manual as a guide to assemble or disassemble the tractor. Some hardware and parts are drawn larger in order to more readily identify them.

Each tractor has its own model number.

The model number for your tractor can be found on the fender under the seat.

When ordering parts, always give the following information:

- Product - "Lawn Tractor"
- Model Number - "YTH2648TDRF" (96041026401/02)
- Part Number
- Part Description

TABLE OF CONTENTS

SCHEMATIC	3
ELECTRICAL.....	4-5
CHASSIS AND ENCLOSURES.....	6-7
DRIVE.....	8-9
ENGINE.....	10-11
STEERING WHEEL	12-13
MOWER DECK	14-15
MOWER LIFT.....	16
SEAT	17
DECALS	18

TRACTOR - MODEL NO. YTH2648TDRF (96041026401/02), PROD. NO. 960 41 02-64 SCHEMATIC

SCH12

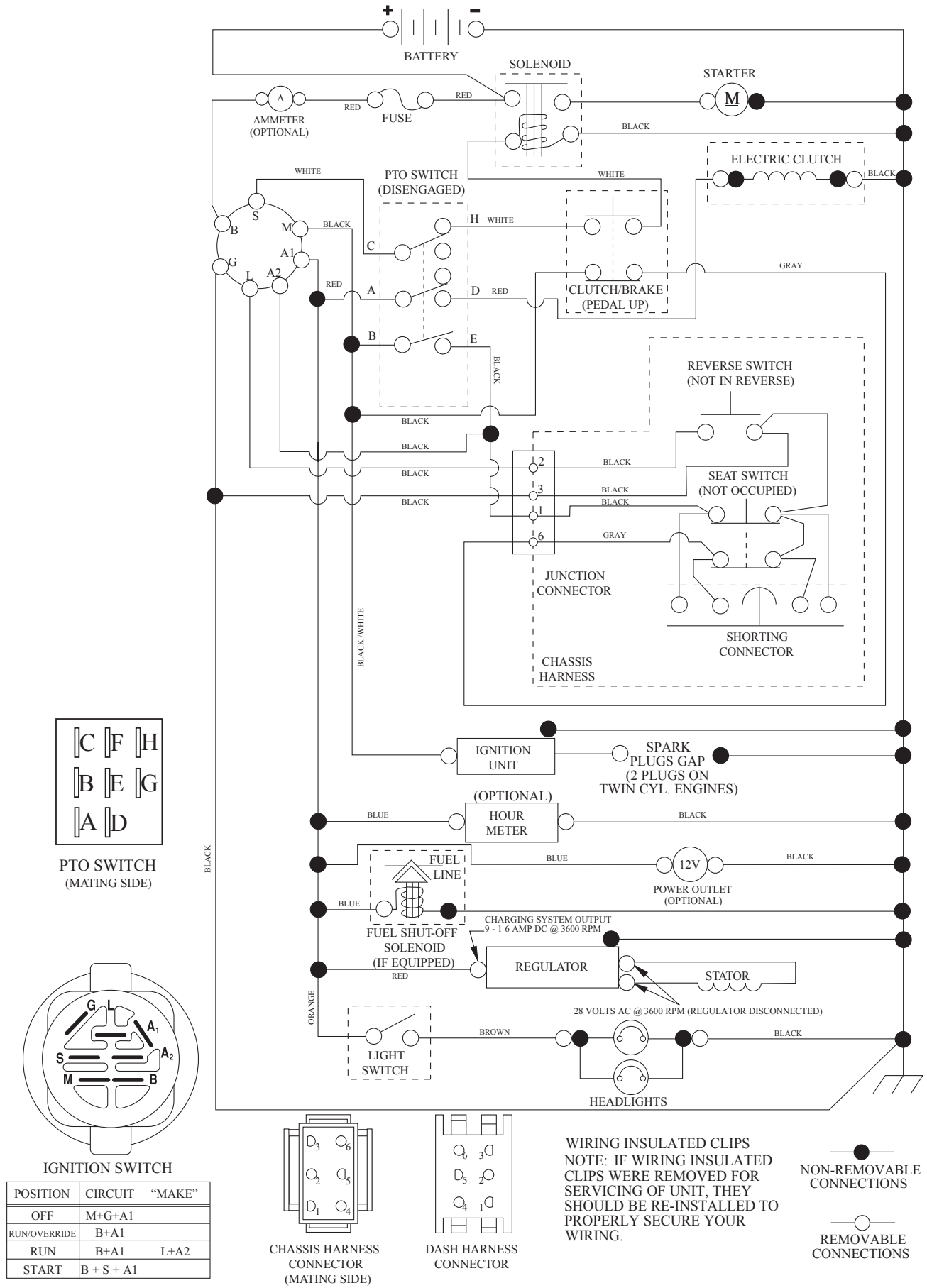

**TRACTOR - MODEL NO. YTH2648TDRF (96041026401/02), PROD. NO. 960 41 02-64
ELECTRICAL**

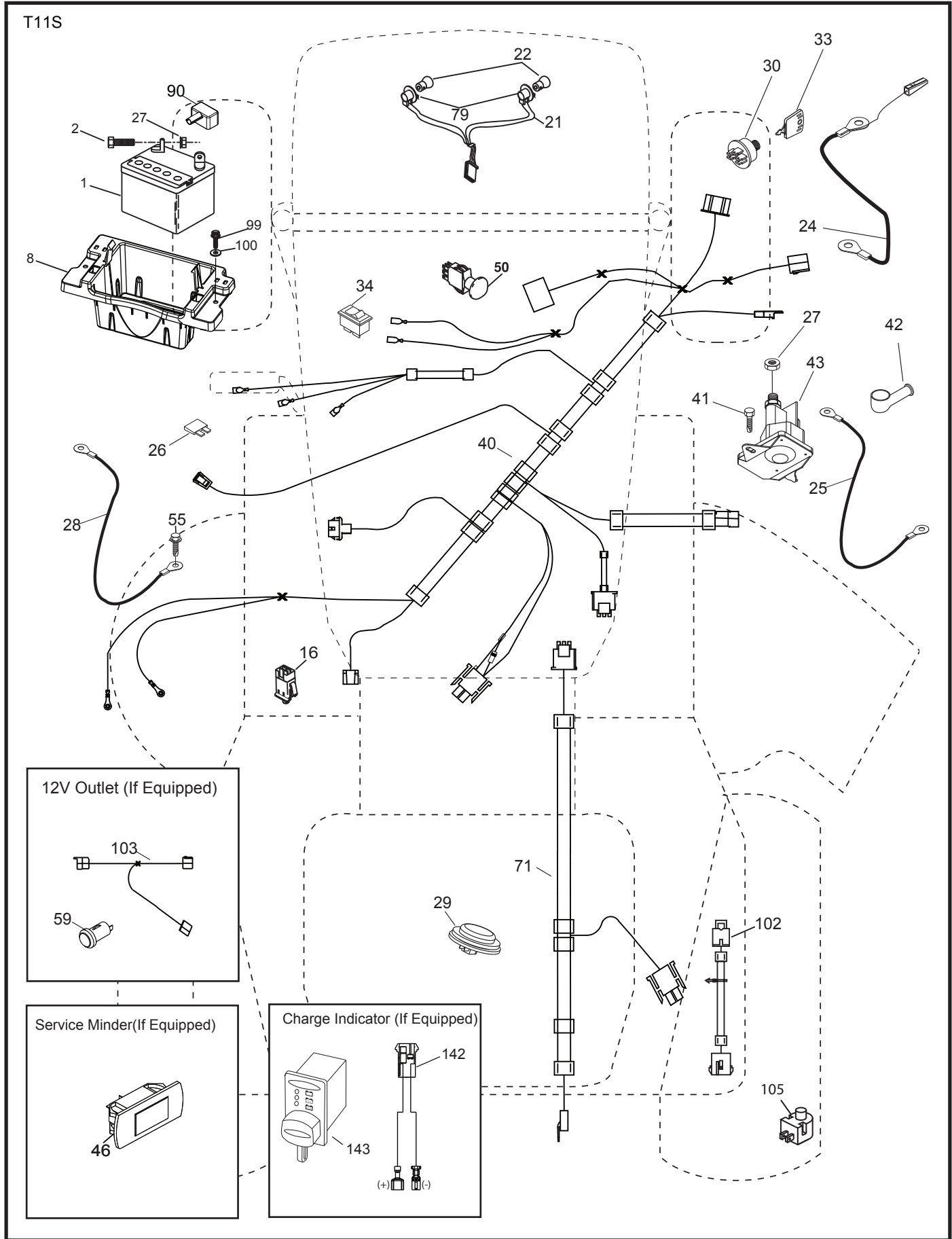

**TRACTOR - MODEL NO. YTH2648TDRF (96041026401/02), PROD. NO. 960 41 02-64
ELECTRICAL**

KEY NO.	PART NO.	DESCRIPTION
1	532 16 34-65	Battery
2	874 76 04-12	Bolt Hex Hd. 1/4-20 unc x 3/4
8	587 20 51-01	Battery Box
16	532 17 61-38	Switch Interlock
21	532 40 02-52	Harness Socket Light
22	532 00 41-52	Bulb, Light # 1156
24	585 55 56-01	Cable Battery
25	585 55 55-01	Cable Starter
26	532 17 51-58	Fuse
27	873 51 04-00	Nut Keps Hex 1/4-20 unc
28	532 41 65-88	Cable Ground 21" Blk. 6 Ga.
29	532 40 15-45	Switch Seat
30	532 19 33-50	Switch Ign.
33	532 41 19-33	Key/Chain
34	532 11 07-12	Switch Light/Reset
40	581 02 27-01	Harness Ignition Dash
41	817 72 04-08	Screw Thd. Cut 1/4-20 x 1/2
42	532 13 15-63	Cover Terminal Red
43	532 19 25-07	Solenoid
46	532 40 17-63	Gauge Hourmeter
50	532 17 46-51	Switch PTO
55	817 06 05-12	Screw Thdrol. 5/16-18 x 3/4
59	532 40 03-03	Outlet 12-Volt
71	532 19 42-76	Harness Chassis
79	532 17 52-42	Socket Asm. Bulb
90	532 43 53-95	Cover Terminal Battery
99	817 67 04-12	Screw Hex Wsh. Thdrol. 1/4-20 x 3/4
100	819 09 14-16	Washer 9/32 x 7/8 x 16 Ga.
102	532 40 44-54	Harness Pigtail
103	532 40 79-62	Harness Pigtail 12V Outlet
105	532 40 75-68	Switch Reverse
142	583 85 78-01	Harness Charge Port
143	532 44 80-59	Charge Port

NOTE: All component dimensions given in U.S. inches
1 inch = 25.4 mm

**TRACTOR - MODEL NO. YTH2648TDRF (96041026401/02), PROD. NO. 960 41 02-64
CHASSIS**

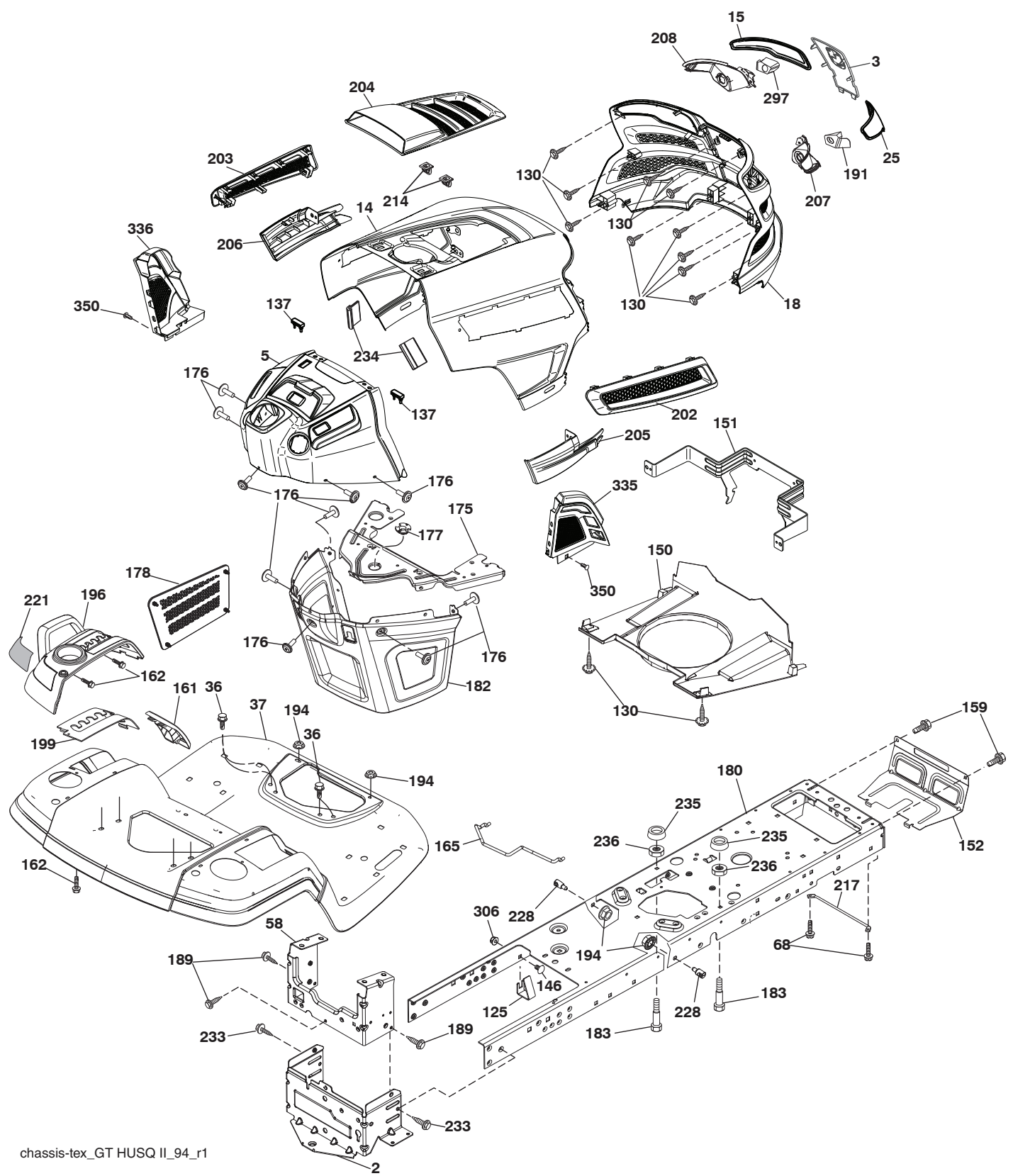

chassis-tex_GT HUSQ II_94_r1

**TRACTOR - MODEL NO. YTH2648TDRF (96041026401/02), PROD. NO. 960 41 02-64
CHASSIS**

KEY NO.	PART NO.	DESCRIPTION	KEY NO.	PART NO.	DESCRIPTION
2	532 41 22-82	Drawbar Lower	191	532 43 74-55	Insert RH
3	532 44 44-81	Applique	194	873 90 05-00	Nut Lock Hex Flange 5/16-18
5	532 43 74-86	Dash	196	532 43 96-74	Console Asm. Deck Lift
14	532 44 11-77	Hood	199	532 19 82-59	Plate Deck Lift
15	532 43 97-33	Lens LH	202	532 43 97-28	Vent Side Hood RH
18	532 44 06-53	Grille Asm.	203	532 43 97-27	Vent Side Hood LH
25	532 44 33-85	Lens RH	204	532 43 57-14	Vent Top Hood
36	817 06 05-12	Screw 5/16-18 x 3/4	205	532 43 97-30	Skirt Hood Side RH
37	532 44 12-08	Fender	206	532 43 97-29	Skirt Hood Side LH
58	532 41 22-81	Drawbar Upper	207	532 43 97-34	Bezel RH
68	817 49 05-08	Screw 5/16-18 x 1/2	208	532 43 97-35	Bezel LH
125	581 68 48-01	Clip Fuel Line	214	532 19 91-45	Clip Retainer Tinner
130	532 41 63-58	Screw #10 x 0.750 BOS Thread	217	532 40 91-67	Rod Pivot
137	532 40 75-90	Bumper Dash	221	532 19 89-09	Reflector LH
146	581 85 79-01	Bolt	228	532 19 51-61	Stud Fastner
150	532 43 97-74	Air Duct	233	532 19 65-39	Bolt Shoulder
151	532 43 66-70	Bracket Pivot	234	532 40 47-42	Bumper Hood
152	532 43 60-86	Shield Browning	235	532 40 61-29	Spacer Fender
159	817 00 06-12	Screw Hexwsh THDR 3/8 - 16x3/4	236	873 93 05-00	Nut Lock 5/16-18 unc
161	532 43 99-29	Window Fuel	297	532 43 74-56	Insert LH
162	532 14 24-32	Screw	306	873 90 06-00	Nut Lock
165	532 19 43-30	Support Tank Rear	335	532 44 82-04	Cover Dash RH
175	532 19 63-04	Crossmember	336	532 44 53-09	Cover Dash LH
176	532 40 07-76	Screw 10-24 x 5/8	350	532 44 51-43	Clip X-mas Tree
177	532 19 52-28	Bushing Steering	--	532 44 80-86	Kit Guard Brush
178	532 19 97-82	Cargo Net Asm.			
180	532 44 55-59	Chassis			
182	532 40 68-59	Dash Lower			
183	874 52 05-20	Bolt 5/16-18 x 1-1/4 Full Thread			
189	817 00 05-12	Screw 5/16-18 x 3/4			

NOTE: All component dimensions given in U.S. inches
1 inch = 25.4 mm

**TRACTOR - MODEL NO. YTH2648TDRF (96041026401/02), PROD. NO. 960 41 02-64
DRIVE**

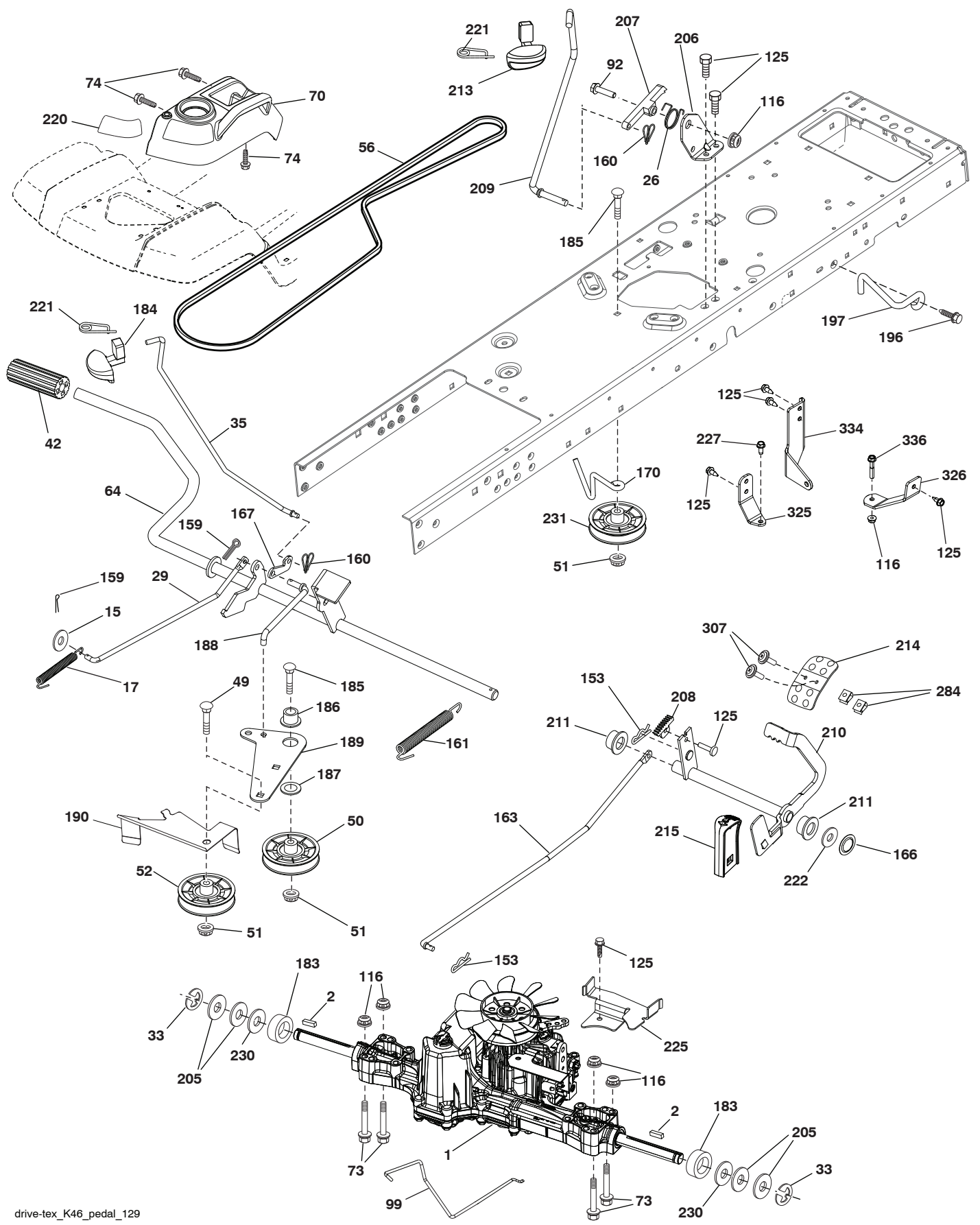

**TRACTOR - MODEL NO. YTH2648TDRF (96041026401/02), PROD. NO. 960 41 02-64
DRIVE**

KEY NO.	PART NO.	DESCRIPTION	KEY NO.	PART NO.	DESCRIPTION
1	---	Transaxle, TUFFTORQ K46CR (501051401) (Order parts from transaxle manufacturer.)	186	532 19 43-21	Spacer Retainer
2	532 12 35-83	Key	187	819 13 32-10	Washer
15	819 13 13-16	Washer 13/32 x 13/16 x 16 Ga.	188	532 19 43-23	Link Clutch Ground Drive
17	532 41 36-78	Spring, Brake	189	532 19 43-17	Bellcrank Ground Drive
26	532 19 96-79	Spring Return Cruise	190	532 19 43-18	Keeper Bellcrank Ground Drive
29	532 40 38-06	Rod, Brake	196	817 00 06-16	Screw 3/8-16 x 1
33	812 00 00-01	Ring E	197	585 65 86-01	Link Clutch Anti-Rotation
35	583 86 45-01	Rod, Brake, Park	205	532 12 17-48	Washer
42	532 12 48-72	Cover, Foot Pedal	206	532 19 78-67	Bracket Mount Latch Cruise
49	872 11 06-14	Bolt	207	532 19 78-68	Latch Control Cruise
50	532 19 43-27	Pulley Idler Flat	208	532 19 78-69	Gear Sector Control Cruise
51	873 90 06-00	Lock Nut 3/8-16	209	532 19 95-92	Rod Control Cruise
52	532 19 43-26	Idler V-Groove	210	532 19 78-60	Rocker Asm. Pedal Control
56	532 13 09-69	V-Belt, Drive	211	532 12 01-83	Bearing Nylon
64	532 19 78-65	Shaft Asm. Pedal Brake Control	213	532 40 31-19	Knob Control Cruise
70	532 43 96-61	Console Shift	214	532 41 68-63	Pedal Forward
73	874 49 05-40	Bolt Hex Flghd 5/16-18 Gr. 5	215	532 40 17-23	Pedal Reverse
74	532 14 24-32	Screw Hex Wsh. Hi-Lo 1/4 x 1/2 unc	220	532 19 89-08	Reflector RH
92	874 76 05-20	Bolt Fin Hex 5/16-18 unc x 1.25	221	532 40 31-87	Retainer Spring Clip Handle
99	532 41 57-42	Rod Spring Bypass	222	879 21 20-10	Washer 21/32 x 1-1/4 x 10 Ga.
116	873 90 05-00	Nut Lock Hex Flange 5/16-18	225	532 40 33-19	Keeper Belt Trans.
125	817 00 05-12	Screw 5/16-18 x 3/4	227	817 49 05-12	Screw Thdrol 5/16-18 x 3/4
153	532 12 47-88	Retainer Spring	230	532 18 89-67	Washer Hardened
159	876 02 04-12	Pin Cotter 1/8 x 3/4	231	532 40 72-87	Idler V-Groove
160	532 16 94-84	Retainer Clip	284	532 41 76-93	Nut U-CHNL 1/4-20
161	532 10 57-09	Spring, Return, Clutch	307	874 18 04-12	Screw MACH CR 1/4-20 x 3/4
163	532 44 82-75	Rod Pedal Control	325	586 43 12-02	Torque Strap K46 LT LH
166	532 42 91-64	Nut Push	326	586 00 11-02	Bracket TRQ STP 46 20" Tire RH
167	532 40 52-57	Latch Brake Parking	334	585 88 22-02	Sway Bar Bracket
170	532 41 34-30	Keeper Belt Centerspan	336	587 25 96-01	Bolt 5/16-18 x 1-3/4 Flanged
183	532 13 70-57	Spacer Split			
184	532 44 14-55	Handle Parking Brake			
185	872 11 06-22	Bolt Rdhd Sqnk 3/8-16 x 2-1/2			

NOTE: All component dimensions given in U.S. inches
1 inch = 25.4 mm

TRACTOR - MODEL NO. YTH2648TDRF (96041026401/02), PROD. NO. 960 41 02-64
ENGINE

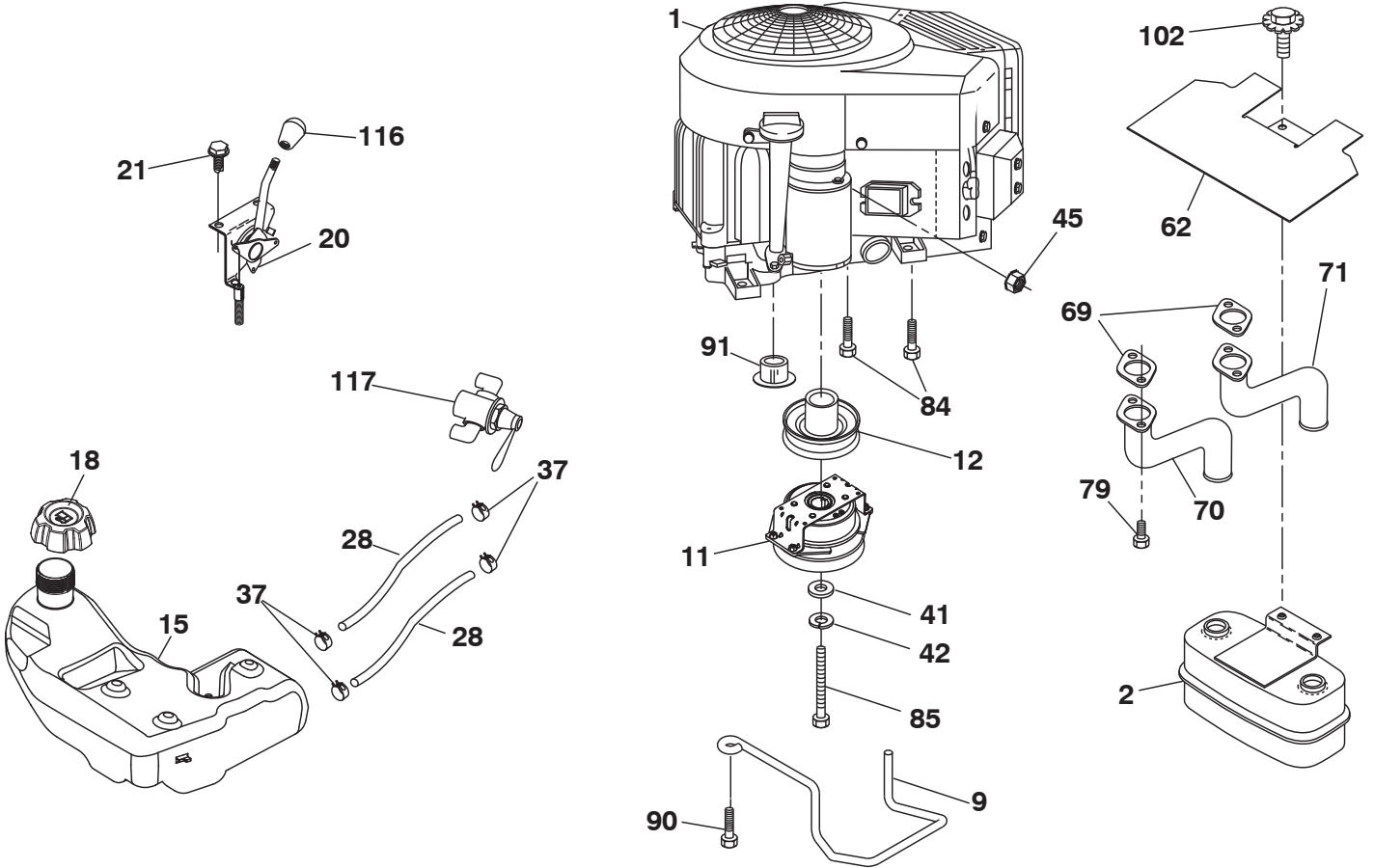

29
SPARK ARRESTER KIT

engine-tex_bs-2cyl_114_r1

TRACTOR - MODEL NO. YTH2648TDRF (96041026401/02), PROD. NO. 960 41 02-64 ENGINE

KEY NO.	PART NO.	DESCRIPTION
1	---	Engine Briggs Model No. 44P777-1573-G5(442257) (Order parts from engine manufacturer.)
2	532 44 59-62	Muffler
9	532 19 43-20	Keeper Belt Engine
11	587 24 16-01	Clutch Electric
12	532 40 50-97	Pulley Engine
15	532 42 28-04	Tank Fuel
18	532 43 96-45	Cap
20	532 42 43-40	Control Throttle
21	532 41 63-58	Screw #10 x .750 BOS Thread
28	532 40 11-35	Fuel Line
29	532 13 71-80	Spark Arrester Kit
37	532 12 34-87	Clamp Hose
41	532 12 61-97	Washer 1-1/2 OD x 15/32 ID x .250
42	810 04 07-00	Washer Lock 7/16
45	873 51 04-00	Nut Keps Hex 1/4-20 unc
62	532 43 40-17	Heat Shield
69	532 16 53-91	Gasket
70	581 88 11-01	Tube Exhaust
71	581 88 10-01	Exhaust Tube
79	532 18 39-06	Screw Socket HP 5/16-18 x 1
84	817 06 06-20	Screw 3/8-16 x 1-1/4
85	532 17 99-53	Bolt 7/16-20 x 3.75 Gr.
90	817 00 06-16	Screw 3/8-16 x 1
91	532 18 74-95	Bushing 1.375 OD
102	817 00 05-12	Screw 5/16-18 x 3/4
116	539 13 26-24	Knob-Shift
117	532 42 08-28	Valve Fuel Reserve

NOTE: All component dimensions given in U.S. inches
1 inch = 25.4 mm

Engine Power Rating Information

The gross power rating for individual gas engine models is labeled in accordance with SAE (Society of Automotive Engineers) code J1940 (Small Engine Power & Torque Rating Procedure), and rating performance has been obtained and corrected in accordance with SAE J1995 (Revision 2002-05). Torque values are derived at 3060 RPM; horsepower values are derived at 3600 RPM. Actual gross engine power will be lower and is affected by, among other things, ambient operating conditions and engine-to-engine variability. Given both the wide array of products on which engines are placed and the variety of environmental issues applicable to operating the equipment, the gas engine will not develop the rated gross power when used in a given piece of power equipment (actual "on-site" or net power). This difference is due to a variety of factors including, but not limited to, accessories (air cleaner, exhaust, charging, cooling, carburetor, fuel pump, etc.), application limitations, ambient operating conditions (temperature, humidity, altitude), and engine-to-engine variability. Due to manufacturing and capacity limitations, Briggs & Stratton may substitute an engine of higher rated power for this Series engine.

TRACTOR - MODEL NO. YTH2648TDRF (96041026401/02), PROD. NO. 960 41 02-64
STEERING ASSEMBLY

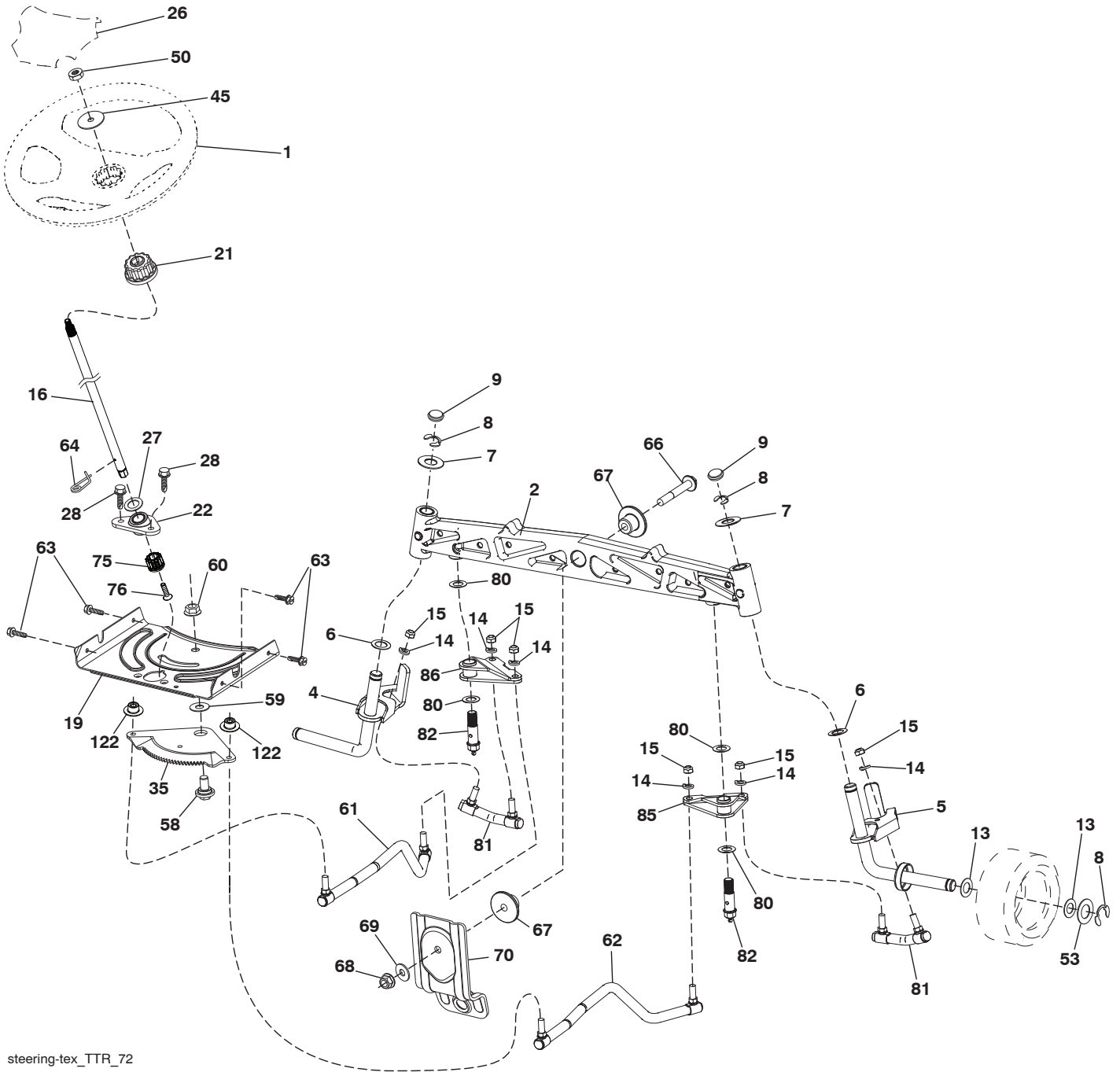

steering-tex_TTR_72

**TRACTOR - MODEL NO. YTH2648TDRF (96041026401/02), PROD. NO. 960 41 02-64
STEERING ASSEMBLY**

KEY NO.	PART NO.	DESCRIPTION
1	532 43 97-40	Wheel, Steering
2	532 43 68-70	Axle Asm., Front
4	532 43 68-73	Spindle Asm., LH
5	532 43 68-74	Spindle Asm., RH
6	532 12 49-31	Washer Thrust 0.75 x 1.23
7	532 12 17-48	Washer 25/32 x 1-5/8 x 16 Ga.
8	812 00 00-29	Ring, Klip #T5304-75
9	532 12 12-32	Cap, Spindle
13	532 12 17-49	Washer 25/32 x 1-1/4 x 16 Ga.
14	810 04 06-00	Washer, Lock 3/8
15	873 54 06-00	Nut, Crown Lock 3/8-24 unf
16	587 01 60-02	Steering Shaft
19	532 19 47-29	Plate Steering
21	586 84 02-01	Adapter, Wheel Steering
22	585 02 99-01	Bearing Shaft
26	532 43 97-43	Insert, Wheel Steering
27	819 21 16-16	Washer 21/32 x 1 x 16 Ga.
28	817 00 06-12	Screw 3/8-16 x 3/4
35	532 44 07-70	Gear, Sector Plate
45	819 18 38-12	Washer
50	873 90 06-00	Nut Hex 1/2-20 unf
53	532 18 89-67	Washer Hardened .793 x 1.637 x .060
58	532 19 47-47	Bolt Shoulder Sector Pivot CFM
59	532 19 47-48	Washer Thrust Sector Steering
60	873 97 10-00	Nut Flange Lock 5/8-11
61	532 43 68-84	Draglink, LH
62	532 43 68-85	Draglink, RH
63	817 00 05-12	Screw 5/16-18 x 3/4
64	532 19 98-49	Retainer Clip Spring Steering
66	871 02 07-48	Bolt Hex Fghd 7/16-14 x 3 Serr
67	532 19 47-37	Bushing PM Front Axle
68	873 90 07-00	Nut Lock Flange 7/16-14 Gr. 5
69	532 19 91-62	Washer 1.5 x .505 x .118
70	532 19 61-97	Bracket Deck Susp. Front
75	580 68 37-01	Pinion
76	580 68 36-01	Screw Head Sock
80	532 00 13-70	Washer
81	532 43 68-87	Link Cross RH
82	532 43 68-77	Pivot Bolt
85	532 44 18-73	Pivot RH
86	532 44 18-72	Pivot LH
122	532 44 49-62	Cap Gear

NOTE: All component dimensions given in U.S. inches
1 inch = 25.4 mm

**TRACTOR - MODEL NO. YTH2648TDRF (96041026401/02), PROD. NO. 960 41 02-64
MOWER DECK**

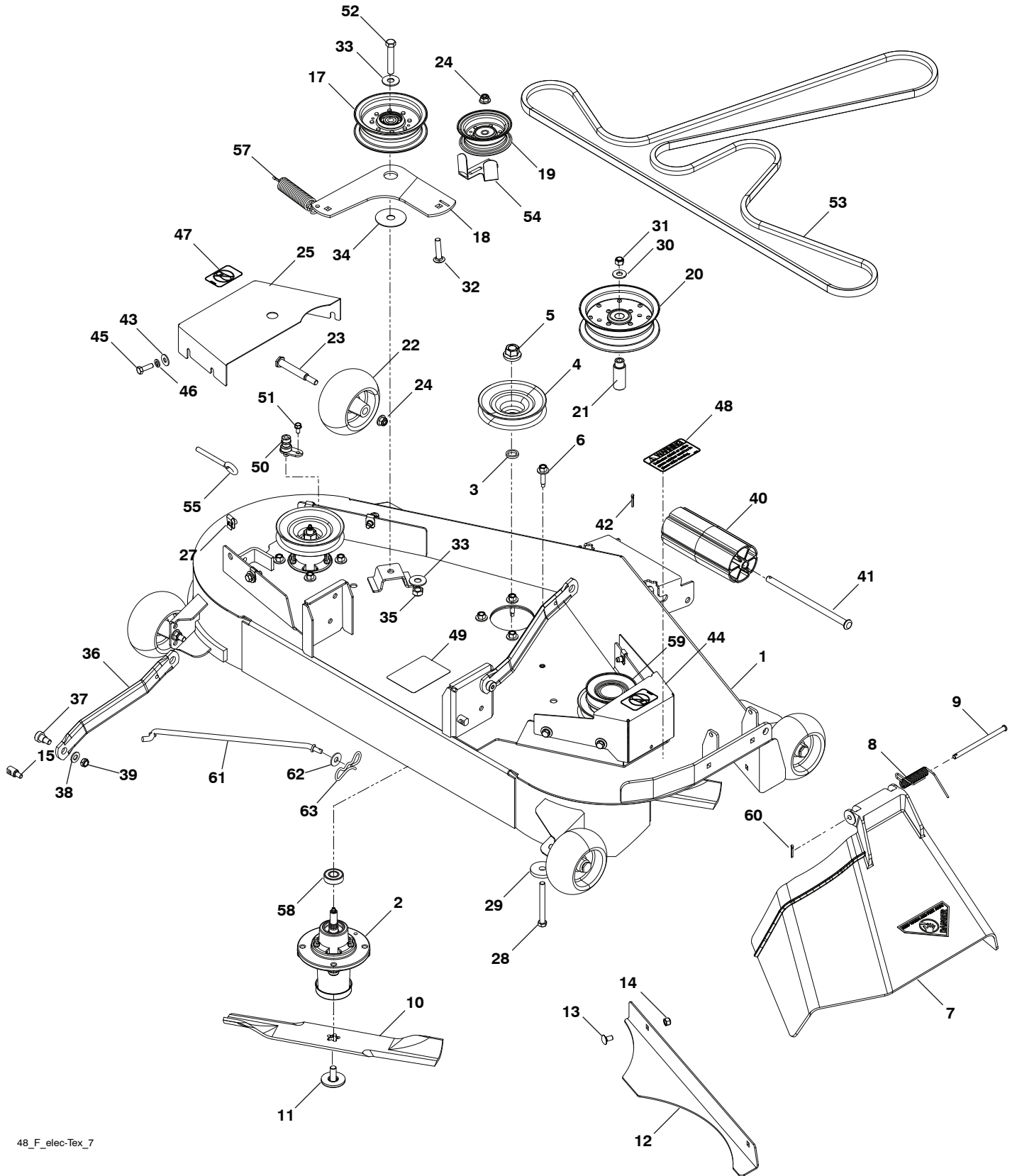

48_F_elec-Tex_7

**TRACTOR - MODEL NO. YTH2648TDRF (96041026401/02), PROD. NO. 960 41 02-64
MOWER DECK**

KEY NO.	PART NO.	DESCRIPTION	KEY NO.	PART NO.	DESCRIPTION
1	587 63 56-01	Deck	37	539 11 36-21	Sb 3/8-16 x 3/8 Skt Hd
2	539 11 21-70	Housing Assembly	38	819 13 13-16	Washer, 13/32 x 13/16 x 16 Ga
3	532 18 76-90	Washer-Spacer	39	539 20 02-82	Nut, 3/8-16 Hex Jam Nyloc
4	532 17 43-75	Pulley, Mandrel	40	532 17 60-66	Roller, Nose
5	532 40 02-34	Nut, Flange Lock Top	41	532 17 91-27	Rod, Roller, Nose, Narrow
6	532 17 39-84	Screw, Thd Roll	42	532 19 42-08	Pin Cotter 5/16 Bow Tie Lock
7	539 11 07-32	Discharge Chute	43	819 12 14-14	Washer, 3/8 x 7/8 x 14 Ga
8	539 11 07-35	Spring - Torsion	44	575 96 72-02	Shield, Belt RH
9	539 11 07-36	Pin, Clevis 5/16 x 5.19	45	874 78 05-16	Bolt Fin Hx 5/16-18 x 1
10	539 11 34-25	Blade, 16-1/4"	46	810 03 05-00	Wash 5/16 Slw
11	532 19 30-03	Bolt, Washer Asm 7/16-20	47	539 10 57-43	Decal, No Step
12	539 11 34-26	Confinement Plate	48	539 11 32-24	Decal, Warning
13	872 11 05-05	Rhsnb 5/16-18 x 5/8 Gr 5	49	532 19 87-85	Decal, Deck Sch
14	873 80 05-00	Nut 5/16-18 Hex Nyloc	50	532 41 55-98	Washout Port
15	532 19 51-61	Stud, Fasten w/ Anti- Rotate	51	817 49 04-08	Bolt, 1/4-20 x 1/2
17	532 19 61-04	Pulley, Idler Spec. Hub	52	874 78 07-40	Hcs 7/16-14 x 2-1/2 Gr 5
18	574 82 71-01	Arm, Idler, Blk	53	574 84 56-02	Belt, Deck
19	532 17 79-68	Pulley, Idler	54	532 14 10-43	Guard, Belt
20	539 13 27-28	Pulley, Idler	55	539 11 55-74	Eyebolt 5/16 x 3-1/2
21	575 22 45-01	Idler Bushing	57	539 10 68-50	Spring
22	532 13 39-57	Wheel, Gauge	58	532 11 04-85	Ball Bearing
23	532 19 34-06	Bolt, Shoulder 3/8 16 x 3-5/8	59	575 35 29-01	Pulley
24	521 99 65-01	Nut 3/8-16 Hex Flg Nyloc	60	532 16 94-84	Clip Retainer
25	575 22 47-02	Shield, Belt LH	61	532 40 48-51	Rod Anti Sway
27	539 10 47-63	Retainer 5/16c U Type	62	819 13 13-12	Washer 13/32 x 13/16 x 12 Ga.
28	539 10 82-71	Hcs 3/8-16 x 3-1/2 Gr 5	63	532 19 42-08	Pin Cotter 5/16 Bow Tie Lock
29	539 10 65-04	Heavy Washer	--	532 44 53-59	Mower Deck Complete
30	819 14 16-14	Washer, 3/8 Flat Std			
31	539 97 69-79	Nut 3/8-16 Hex Nyloc			
32	539 99 09-23	Rhsnb 3/8-16 x 1-3/4 Gr 5			
33	539 10 48-64	Washer, 7/16 Flat			
34	532 17 85-15	Washer, Flat Hardened			
35	873 90 07-00	Nut, 7/16-14 Hex			
36	532 19 51-85	Arm, Susp., Rear			

NOTE: All component dimensions given in U.S. inches
1 inch = 25.4 mm

**TRACTOR - MODEL NO. YTH2648TDRF (96041026401/02), PROD. NO. 960 41 02-64
MOWER LIFT**

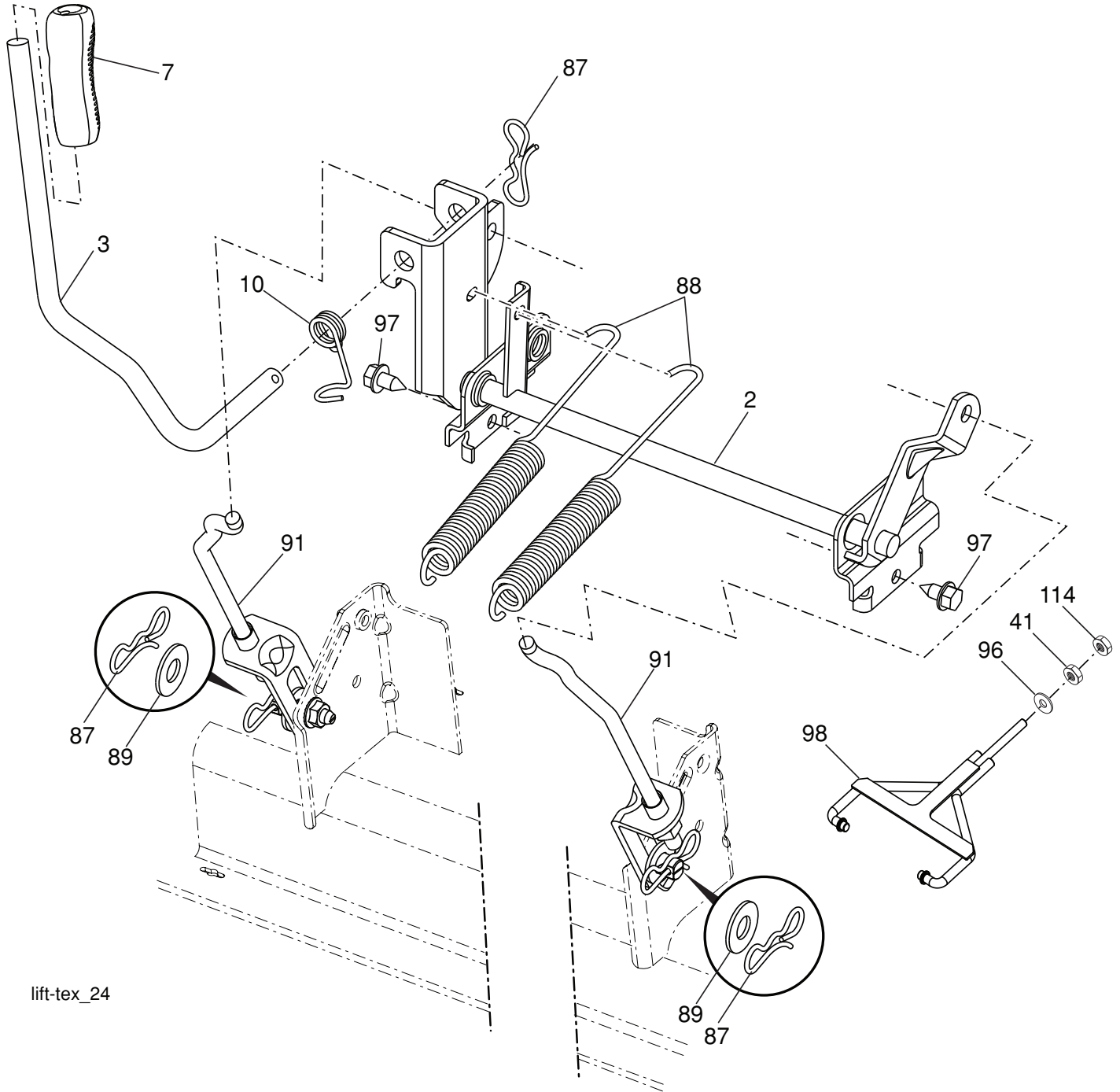

lift-tex_24

KEY NO.	PART NO.	DESCRIPTION
2	532 42 20-27	Shaft Asm., Lift
3	532 19 52-30	Lever Asm., Lift RH
7	532 41 15-55	Grip, Lever
10	532 19 63-14	Spring Torsion
41	532 17 59-94	Nut, Lift Link
87	532 19 42-09	Pin Cotter 7/16 Bow Tie Lock
88	532 41 07-10	Spring Lift Assist
89	819 19 19-12	Washer Clear Zinc

KEY NO.	PART NO.	DESCRIPTION
91	532 40 34-07	Link Lift Susp Mower Rear
96	532 19 52-63	Bushing, Spherical
97	817 00 06-12	Screw 3/8-16 x .75
98	574 82 25-01	Link Lift Susp. Front Mower
114	873 36 07-00	Nut Jam 7/16-20

NOTE: All component dimensions given in U.S. inches
1 inch = 25.4 mm

**TRACTOR - MODEL NO. YTH2648TDRF (96041026401/02), PROD. NO. 960 41 02-64
SEAT ASSEMBLY**

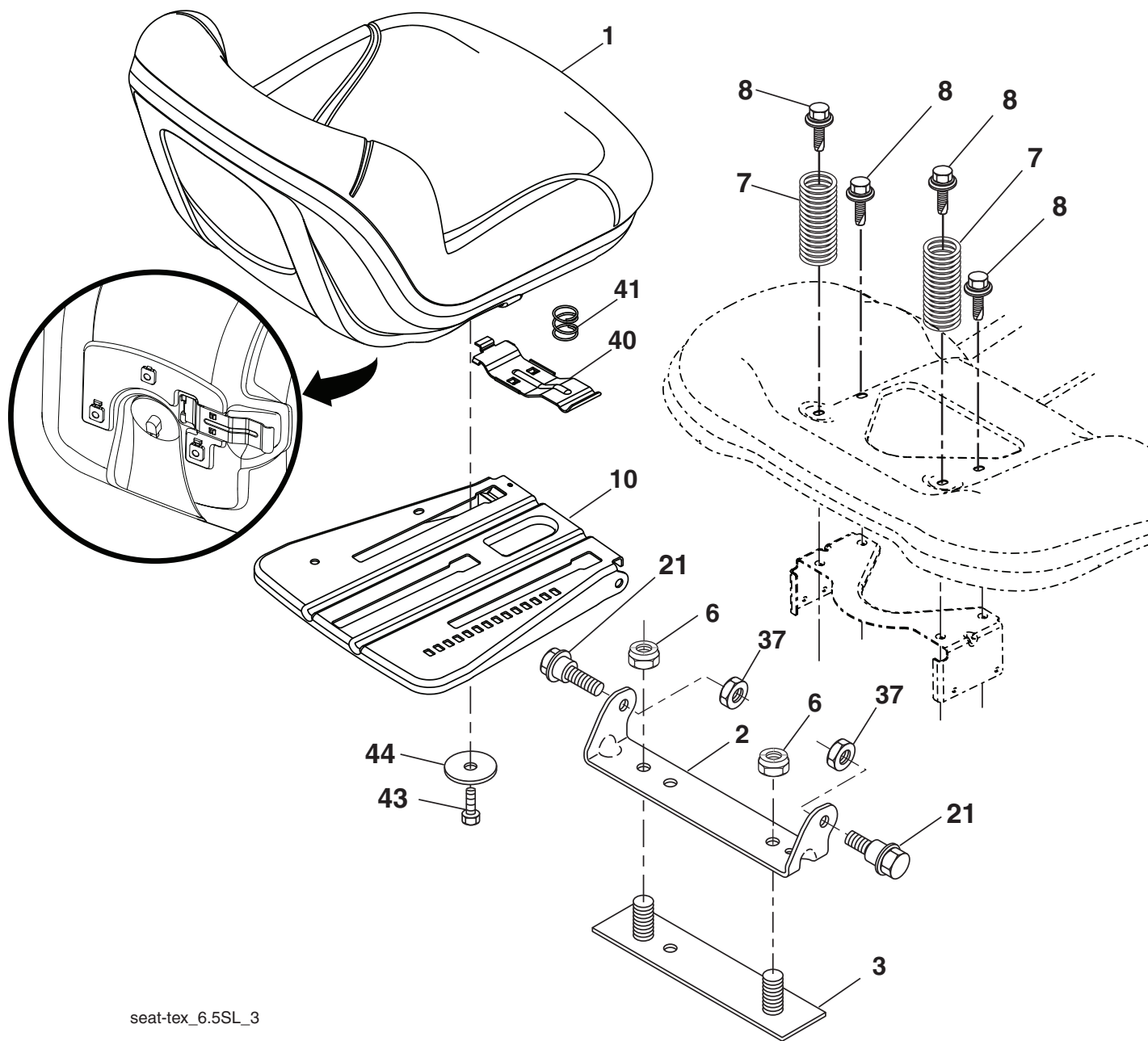

seat-tex_6.5SL_3

KEY NO.	PART NO.	DESCRIPTION
1	532 44 32-63	Seat
2	532 18 01-66	Bracket Pivot Fender
3	532 14 06-75	Strap, Asm Fender
6	873 80 06-00	Nut, Lock w/Ins. 3/8-16 unc
7	532 12 41-81	Spring, Seat Cprsn
8	532 17 18-77	Bolt 5/16-18 unc x 3/4 w/Sems
10	532 19 69-77	Pan, Seat
21	532 17 18-52	Bolt, Shoulder 5/16-18

KEY NO.	PART NO.	DESCRIPTION
37	873 80 05-00	Nut, Lock 5/16-18 unc
40	532 43 98-71	Handle Slide Seat
41	532 19 82-00	Spring Latch Seat
43	874 76 06-12	Bolt Fin Hex 3/8-16 unc x 3/4
44	819 13 38-12	Washer 13/32 x 2-3/8 x 12 Ga.

NOTE: All component dimensions given in U.S. inches
1 inch = 25.4 mm

**TRACTOR - MODEL NO. YTH2648TDRF (96041026401/02), PROD. NO. 960 41 02-64
DECALS**

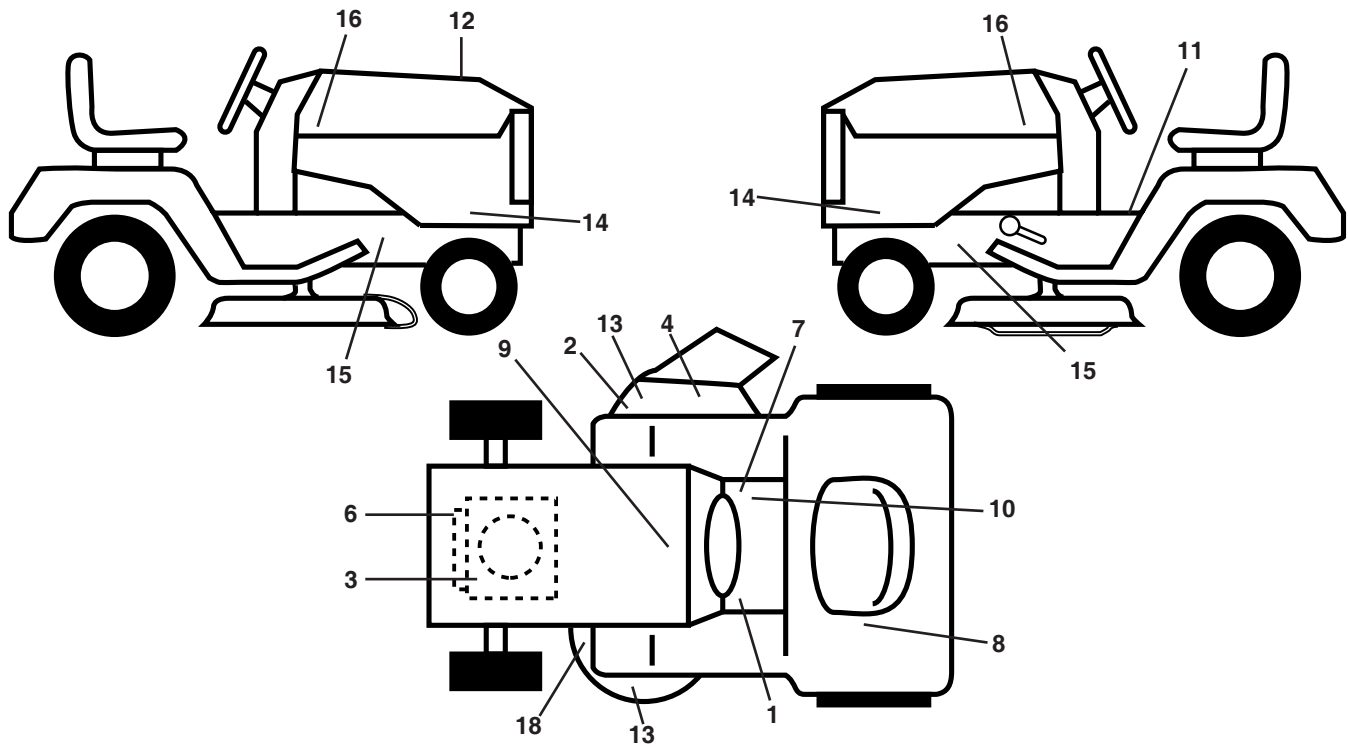

**KEY PART
NO. NO.**

DESCRIPTION

1	581 72 40-01	Decal, Brake/Clutch Sym
2	581 57 92-01	Decal, Warning Symbol
3	532 43 29-17	Decal, Eng. H.P.
4	584 90 46-01	Decal, Deck/Deflect. Warning
6	581 57 97-01	Decal, Warning Eng. Syms.
7	581 57 80-01	Decal, Saddle Brake Parking
8	581 72 42-01	Decal, Warn. Reserve Fuel
9	532 14 50-05	Decal, Battery Dan./Poi.
10	581 57 86-01	Decal, Oper. Cruise Sym.
11	581 57 81-01	Decal, Warning Sym. CE
12	532 44 38-42	Decal, RPL
13	581 72 43-01	Decal, No Step

**KEY PART
NO. NO.**

DESCRIPTION

14	532 44 44-61	Decal, Panel Side
15	581 57 96-01	Decal, Chassis Hot Muffler
16	581 62 73-01	Decal, Badge Logo
18	581 58 00-02	Decal, Mower DFLCTR Warning CTFNGR
--	581 72 48-01	Decal, Bypass
--	532 43 98-82	Pad, Footrest, LH
--	532 43 98-81	Pad, Footrest, RH
--	581 72 46-01	Decal, Drawbar Load
--	532 44 83-71	Manual, Oper. Eng.
--	532 44 83-72	Manual, Parts

WHEELS AND TIRES

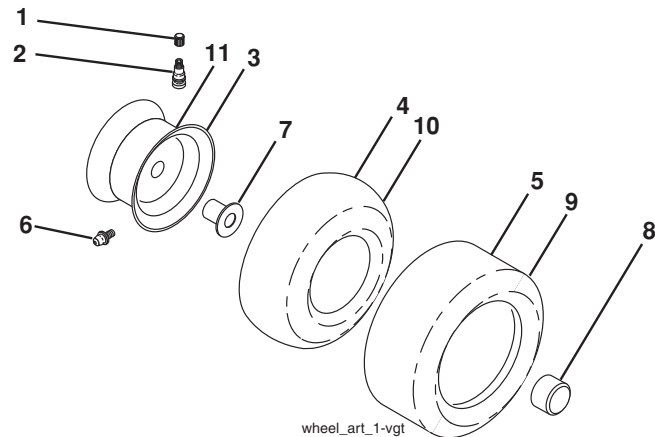

**KEY PART
NO. NO.**

DESCRIPTION

1	532 05 91-92	Cap, Valve, Tire
2	532 06 51-39	Stem, Valve
3	532 18 18-39	Rim Assembly, Front
4	532 00 81-34	Tube, Front (Service Item Only)
5	532 10 62-30	Tire, Front
6	532 12 49-57	Fitting, Grease (Front Wheel Only)
7	532 12 49-59	Bearing, Flange (Front Wheel Only)
8	532 17 50-39	Cap, Axle
9	532 12 20-82	Tire, Rear
10	532 12 49-26	Tube, Rear (Service Item Only)
11	532 13 83-37	Rim Assembly, Rear
--	532 14 43-34	Sealant, Tire (10 oz. Tube)

NOTE: All component dimensions given in U.S. inches
1 inch = 25.4 mm

SERVICE NOTES

08/18/2015 CL