

ILLUSTRATED PARTS LIST

MODEL NUMBER 1650EXL

PRODUCT NUMBER 961 93 00-87

MFG. ID. NUMBER 96193008703

REPAIR PARTS

AUGER HOUSING / IMPELLER ASSEMBLY

SNOW THROWER - MODEL NO. **1650EXL** (96193008703), PRODUCT NO. 961 93 00-87

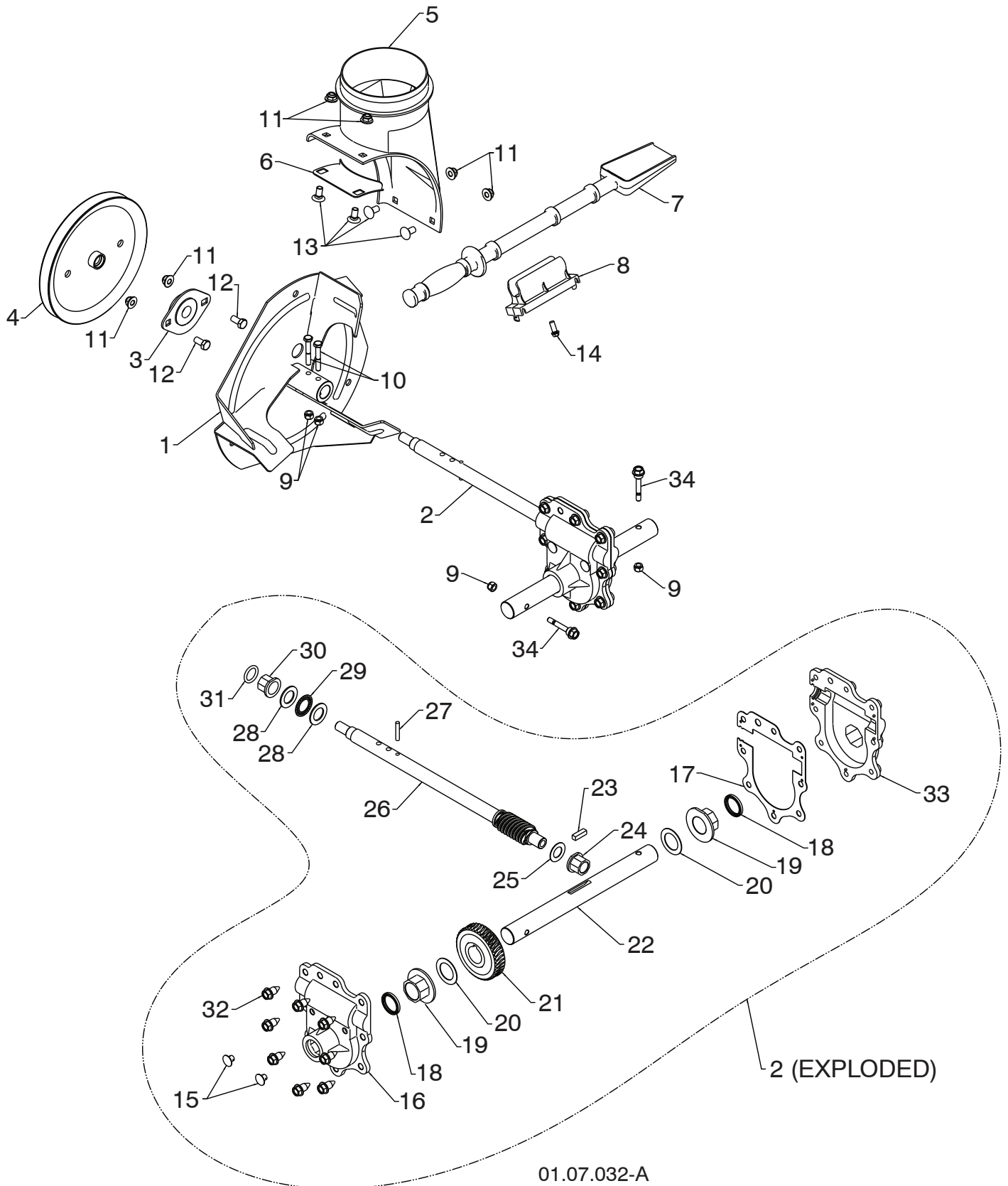

REPAIR PARTS

AUGER HOUSING / IMPELLER ASSEMBLY

SNOW THROWER - MODEL NO. **1650EXL** (96193008703), PRODUCT NO. 961 93 00-87

KEY NO.	PART NO.	DESCRIPTION
1	532 18 41-05	IMPELLER
2	584 64 83-01	GEARBOX ASSEMBLY
3	532 18 89-09	BEARING
4	585 09 32-01	IMPELLER PULLEY
5	532 44 24-38	DISCHARGE BASE
6	532 18 40-95	CORNER BRACKET
7	532 19 21-99	CLEAN OUT TOOL
8	532 40 54-00	TOOL CLIP
9	873 80 04-00	NUT 1/4-20
10	874 78 04-26	SCREW 1/4-20 X .625
11	532 42 79-42	NUT 5/16-18
12	532 16 31-83	SCREW 5/16-18 X .625
13	532 18 03-55	CARRIAGE BOLT
14	532 19 41-89	SCREW 13-16 X .625
15	532 40 77-60	PLUG
16	532 42 73-02	GEARBOX COVER RH
17	532 42 73-45	GASKET
18	532 40 77-70	SEAL
19	532 40 77-62	BEARING
20	532 17 46-97	THRUST WASHER 1.00
21	532 40 77-63	WORM GEAR
22	532 40 77-64	AUGER SHAFT
23	532 18 92-82	SQUARE KEY
24	532 40 77-58	BEARING
25	532 17 46-83	THRUST WASHER
26	584 64 84-01	IMPELLER SHAFT
27	532 18 42-05	ROLL PIN
28	532 17 46-81	THRUST WASHER
29	532 17 46-84	THRUST BEARING
30	532 40 77-69	BEARING
31	532 40 77-68	O-RING
32	532 40 77-67	SCREW 5/16-18 X .750
33	532 42 73-17	GEARBOX COVER LH
34	532 19 20-90	SHEAR BOLT

NOTE: All component dimensions given in U.S. inches. 1 inch = 25.4 mm
IMPORTANT: Use only Original Equipment Manufacturer (O.E.M.) replacement parts.
Failure to do so could be hazardous, damage your snow thrower and void your warranty.

REPAIR PARTS

AUGER HOUSING / IMPELLER ASSEMBLY

SNOW THROWER - MODEL NO. **1650EXL** (96193008703), PRODUCT NO. 961 93 00-87

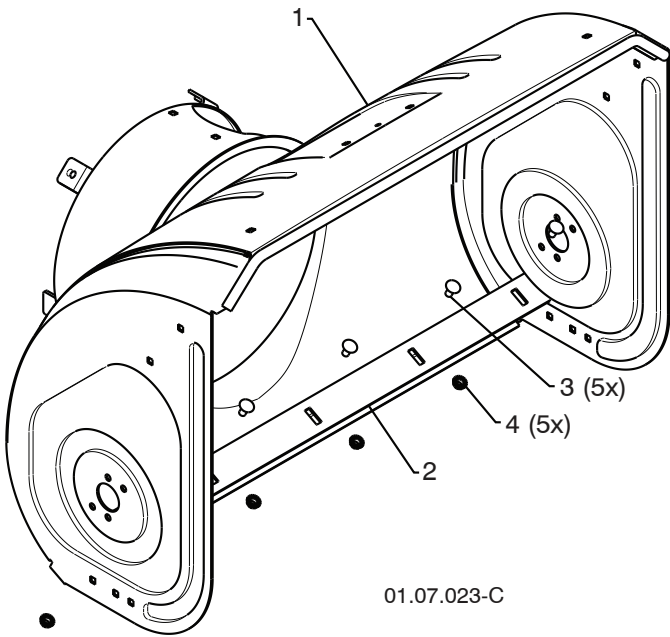

01.07.023-C

KEY NO.	PART NO.	DESCRIPTION
1	532 42 93-92	AUGER HOUSING
2	532 40 76-45	SCRAPER BAR
3	872 27 05-05	CARRIAGE BOLT 5/16-18 X .625
4	532 15 53-77	NUT 5/16-18

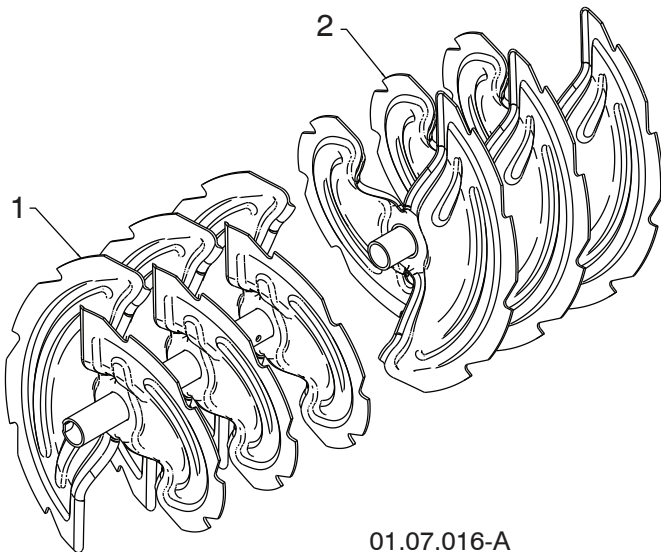

01.07.016-A

KEY NO.	PART NO.	DESCRIPTION
1	532 42 69-59	AUGER ASSEMBLY 30 LH
2	532 43 55-54	AUGER ASSEMBLY 30 RH

NOTE: All component dimensions given in U.S. inches. 1 inch = 25.4 mm
IMPORTANT: Use only Original Equipment Manufacturer (O.E.M.) replacement parts.
 Failure to do so could be hazardous, damage your snow thrower and void your warranty.

REPAIR PARTS

AUGER HOUSING / IMPELLER ASSEMBLY

SNOW THROWER - MODEL NO. 1650EXL (96193008703), PRODUCT NO. 961 93 00-87

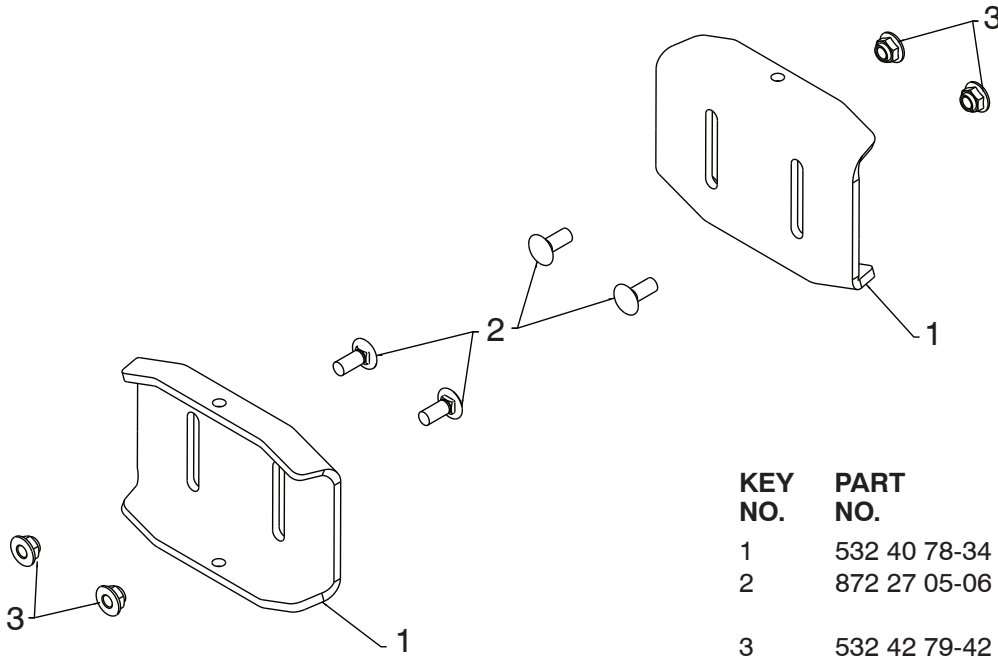

01.11.002-C

KEY NO.	PART NO.	DESCRIPTION
1	532 40 78-34	SKID PLATE
2	872 27 05-06	CARRIAGE BOLT 5/16-18 X .750
3	532 42 79-42	NUT 5/16-18

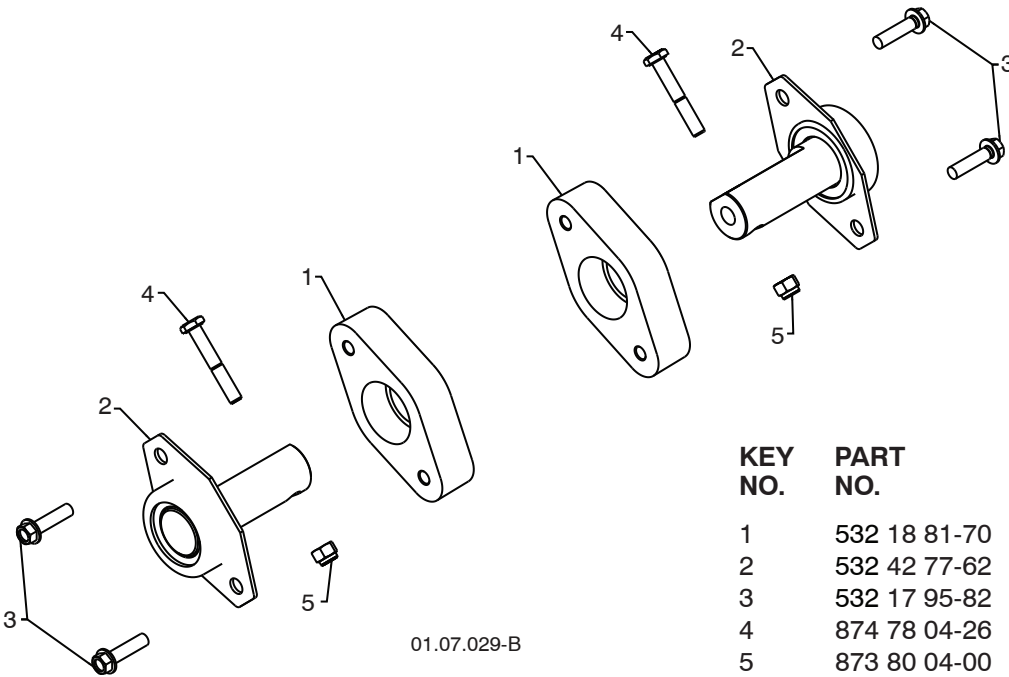

01.07.029-B

KEY NO.	PART NO.	DESCRIPTION
1	532 18 81-70	PLASTIC RETAINER
2	532 42 77-62	AUGER BALL BEARING
3	532 17 95-82	SCREW 5/16-18 X 1.00
4	874 78 04-26	SCREW 1/4-20 X .625
5	873 80 04-00	NUT 1/4-20

NOTE: All component dimensions given in U.S. inches. 1 inch = 25.4 mm
IMPORTANT: Use only Original Equipment Manufacturer (O.E.M.) replacement parts. Failure to do so could be hazardous, damage your snow thrower and void your warranty.

REPAIR PARTS

AUGER HOUSING / IMPELLER ASSEMBLY

SNOW THROWER - MODEL NO. **1650EXL** (96193008703), PRODUCT NO. 961 93 00-87

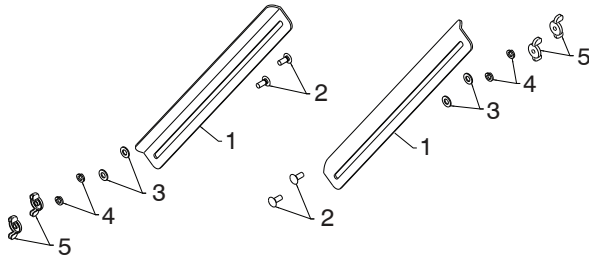

01.16.001-B

KEY NO.	PART NO.	DESCRIPTION
1	532 18 47-47	DRIFT CUTTER BAR
2	872 27 05-06	CARRIAGE BOLT 5/16-18 X .750
3	532 17 92-46	PLASTIC WASHER
4	810 04 05-00	LOCKWASHER 5/16
5	532 12 86-38	NUT 5/16-18

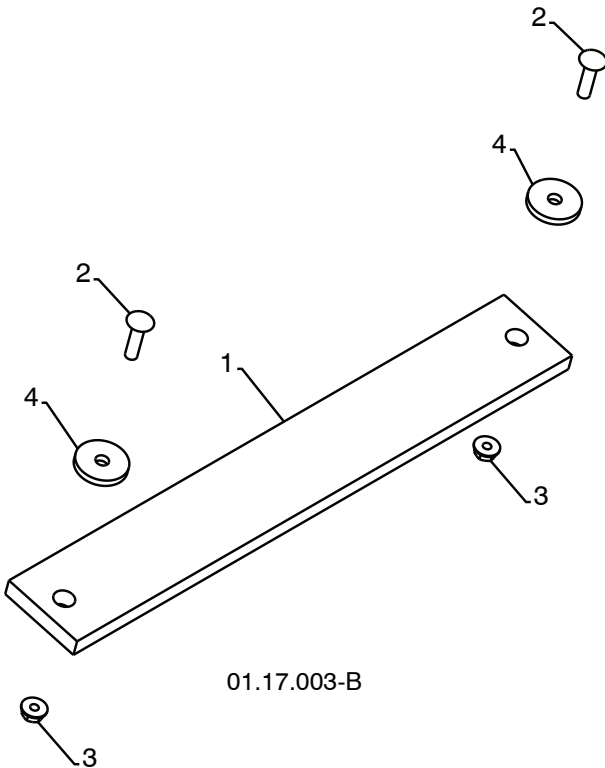

01.17.003-B

KEY NO.	PART NO.	DESCRIPTION
1	532 18 25-16	WEIGHT BAR
2	872 11 05-10	CARRIAGE BOLT 5/16-18 X 1.25
3	532 75 11-53	NUT 5/16-18
4	819 11 22-06	WASHER

NOTE: All component dimensions given in U.S. inches. 1 inch = 25.4 mm
IMPORTANT: Use only Original Equipment Manufacturer (O.E.M.) replacement parts. Failure to do so could be hazardous, damage your snow thrower and void your warranty.

REPAIR PARTS

CONTROL PANEL / DISCHARGE CHUTE

SNOW THROWER - MODEL NO. **1650EXL** (96193008703), PRODUCT NO. 961 93 00-87

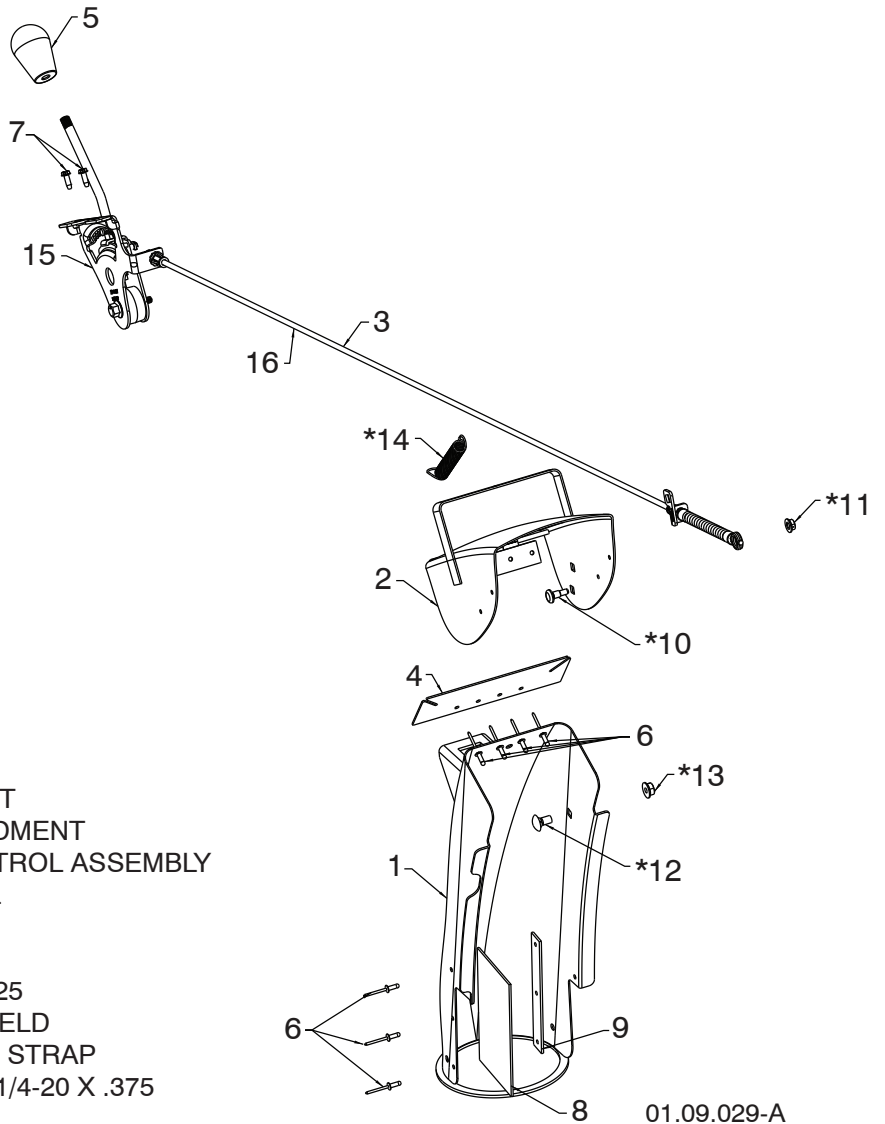

KEY NO.	PART NO.	DESCRIPTION
1	532 44 40-41	CHUTE WELDMENT
2	532 18 41-13	DEFLECTOR WELDMENT
3	585 27 17-01	DEFLECTOR CONTROL ASSEMBLY
4	532 42 03-25	DEFLECTOR SEAL
5	580 67 32-01	KNOB BLACK
6	532 12 84-15	POP RIVET
7	817 54 10-08	SCREW 10-24 X .625
8	532 43 03-24	CHUTE SHOW SHIELD
9	532 42 17-28	SHIELD RETAINER STRAP
*10	532 17 98-29	SHOULDER BOLT 1/4-20 X .375
*11	532 19 17-30	NUT 1/4-20
*12	872 25 05-05	CARRIAGE BOLT 3/8-16 X .625
*13	532 75 11-53	NUT 5/16-18
*14	532 18 45-05	DEFLECTOR SPRING
15	532 42 06-79	(SERVICE PART) DEFLECTOR CONTROL
16	585 27 16-01	(SERVICE PART) DEFLECTOR CABLE BLACK

NOTE:

1. ALL ITEMS INDICATED WITH AN * ARE PROVIDED IN THE BAG OF ITEMS SHIPPED LOOSE WITH PRODUCT.
2. ITEMS 15 AND 16 ARE SERVICE PART NUMBERS TO ALLOW PURCHASE OF INDIVIDUAL ITEMS IF NECESSARY.

NOTE: All component dimensions given in U.S. inches. 1 inch = 25.4 mm
IMPORTANT: Use only Original Equipment Manufacturer (O.E.M.) replacement parts. Failure to do so could be hazardous, damage your snow thrower and void your warranty.

REPAIR PARTS

CONTROL PANEL / DISCHARGE CHUTE

SNOW THROWER - MODEL NO. **1650EXL** (96193008703), PRODUCT NO. 961 93 00-87

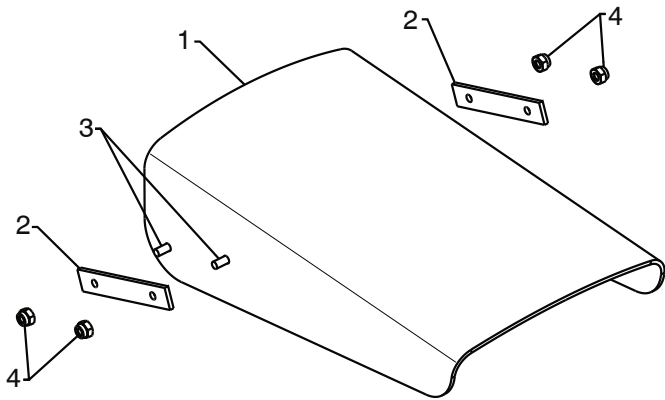

01.09.009-A

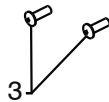

KEY NO.	PART NO.	DESCRIPTION
1	532 42 11-38	SHIELD DEFLECTOR
2	532 42 32-47	STRAP
3	532 18 22-27	SCREW 8-32 X .50
4	532 18 22-28	NUT 8-32

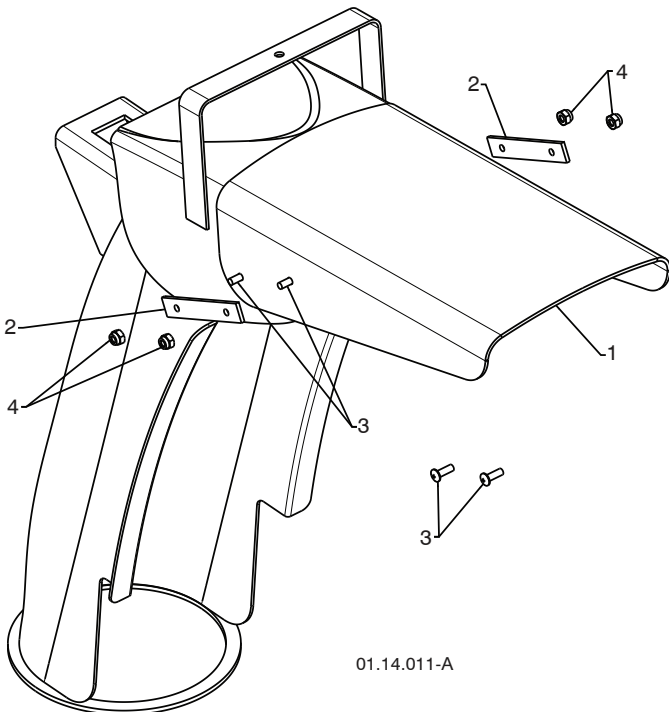

01.14.011-A

KEY NO.	PART NO.	DESCRIPTION
1	532 42 11-38	SHIELD DEFLECTOR
2	532 42 32-47	STRAP
3	532 18 22-27	SCREW 8-32 X .50
4	532 18 22-28	NUT 8-32

NOTE: All component dimensions given in U.S. inches. 1 inch = 25.4 mm
IMPORTANT: Use only Original Equipment Manufacturer (O.E.M.) replacement parts.
Failure to do so could be hazardous, damage your snow thrower and void your warranty.

REPAIR PARTS

CONTROL PANEL / DISCHARGE CHUTE

SNOW THROWER - MODEL NO. **1650EXL** (96193008703), PRODUCT NO. 961 93 00-87

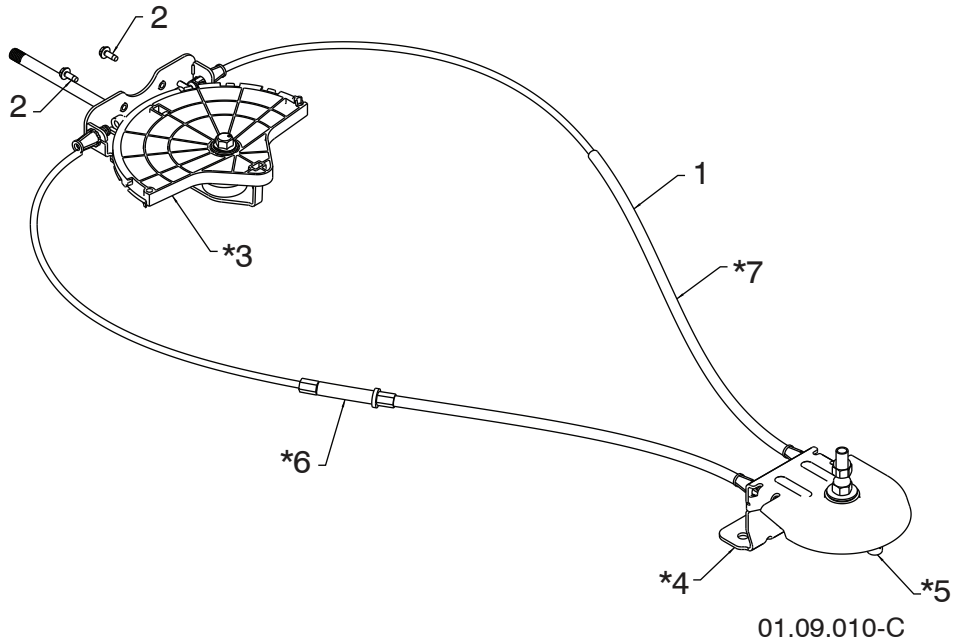

KEY NO.	PART NO.	DESCRIPTION
1	532 42 82-72	LEVER/CABLE ROTATOR ASSEMBLY
2	817 54 10-08	SCREW 10-24 X .625
*3	532 42 06-78	ROTATOR HEAD
*4	532 40 59-32	ROTATOR PIVOT BRACKET
*5	532 42 06-75	PULLEY PIVOT
*6	532 42 82-73	CABLE ASSEMBLY ADJUSTABLE
*7	532 42 83-10	CABLE ASSEMBLY HEAT SHIELD

NOTES:

1. ITEMS INDICATED WITH AN * ARE LISTED AS REFERENCE FOR SERVICE PARTS ONLY.

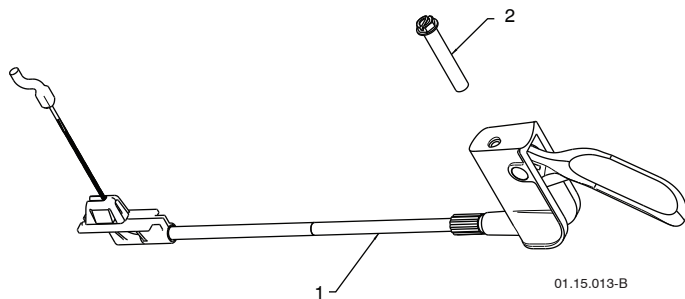

KEY NO.	PART NO.	DESCRIPTION
1	532 42 57-99	STEER CABLE
2	874 04 10-24	SCREW 10-24 X 1.50

NOTE: All component dimensions given in U.S. inches. 1 inch = 25.4 mm
IMPORTANT: Use only Original Equipment Manufacturer (O.E.M.) replacement parts. Failure to do so could be hazardous, damage your snow thrower and void your warranty.

REPAIR PARTS

HANDLES

SNOW THROWER - MODEL NO. **1650EXL** (96193008703), PRODUCT NO. 961 93 00-87

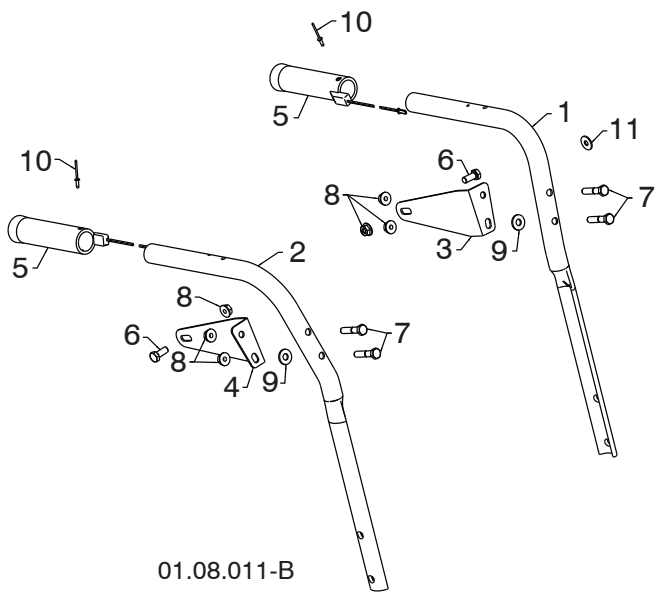

KEY NO.	PART NO.	DESCRIPTION
1	532 42 17-08	PLOW HANDLE LH
2	532 42 17-09	PLOW HANDLE RH
3	532 42 91-48	PANEL BRACKET LH
4	532 42 91-49	PANEL BRACKET RH
5	532 41 45-15	HEATED HANDLE GRIP
6	874 78 05-12	SCREW 5/16-18 X .750
7	874 78 05-24	SCREW 5/16-18 X 1.50
8	532 75 11-53	NUT 5/16-18
9	532 15 54-15	WASHER
10	532 17 87-75	POP RIVET 1/8
11	532 05 38-47	WASHER

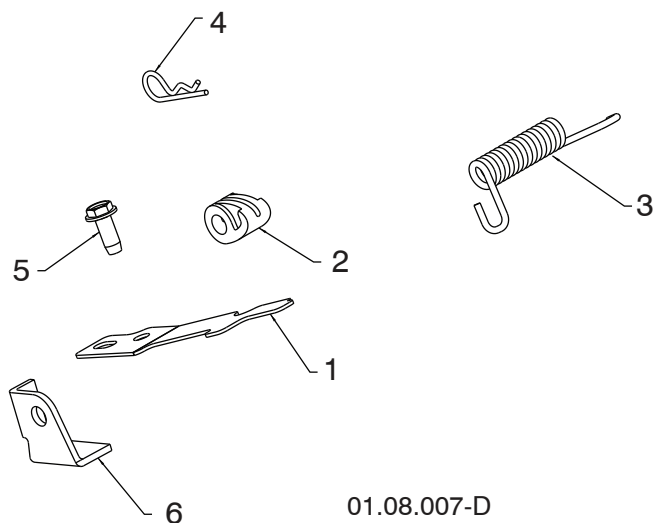

KEY NO.	PART NO.	DESCRIPTION
1	532 41 62-88	INTERLOCK SPRING
2	532 44 52-91	INTERLOCK CAM
3	532 44 32-15	TORSION SPRING
4	532 16 96-75	RETAINER
5	817 06 04-10	SCREW 1/4-20 X .625
6	532 42 18-14	INTERLOCK STOP

NOTE: All component dimensions given in U.S. inches. 1 inch = 25.4 mm
IMPORTANT: Use only Original Equipment Manufacturer (O.E.M.) replacement parts. Failure to do so could be hazardous, damage your snow thrower and void your warranty.

REPAIR PARTS

HANDLES

SNOW THROWER - MODEL NO. **1650EXL** (96193008703), PRODUCT NO. 961 93 00-87

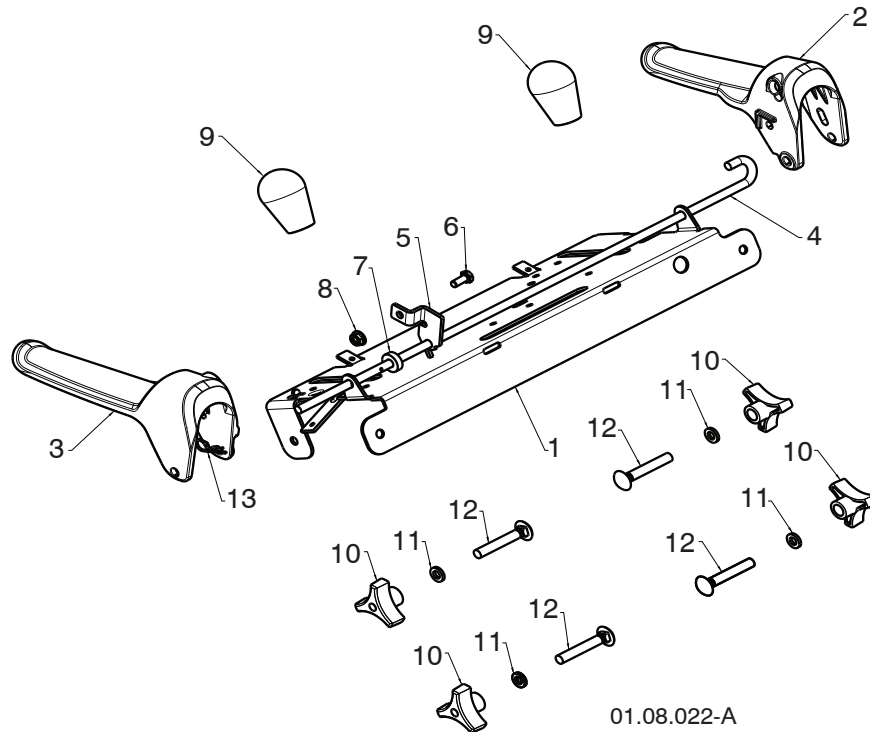

KEY NO.	PART NO.	DESCRIPTION
1	585 19 88-02	CONTROL PANEL
2	581 77 98-01	LH CONTROL LEVER
3	581 77 97-01	RH CONTROL LEVER
4	584 80 90-01	INTERLOCK CONTROL ROD
5	585 00 47-03	INTERLOCK BRACKET
6	874 78 04-10	1/4-20 X .625 HEX HEAD SCREW
7	532 42 16-13	SPACER
8	532 08 83-49	1/4-20 FLANGE NUT (TOP LOCK)
9	580 67 32-01	KNOB SOFT TOUCH
10	532 17 88-99	HANDLE KNOB
11	819 13 13-16	3/8 WASHER
12	872 12 06-18	CARRIAGE BOLT 3/8-16 X 2.25
13	532 16 96-75	RETAINER

NOTE: All component dimensions given in U.S. inches. 1 inch = 25.4 mm
IMPORTANT: Use only Original Equipment Manufacturer (O.E.M.) replacement parts. Failure to do so could be hazardous, damage your snow thrower and void your warranty.

REPAIR PARTS

HANDLES

SNOW THROWER - MODEL NO. **1650EXL** (96193008703), PRODUCT NO. 961 93 00-87

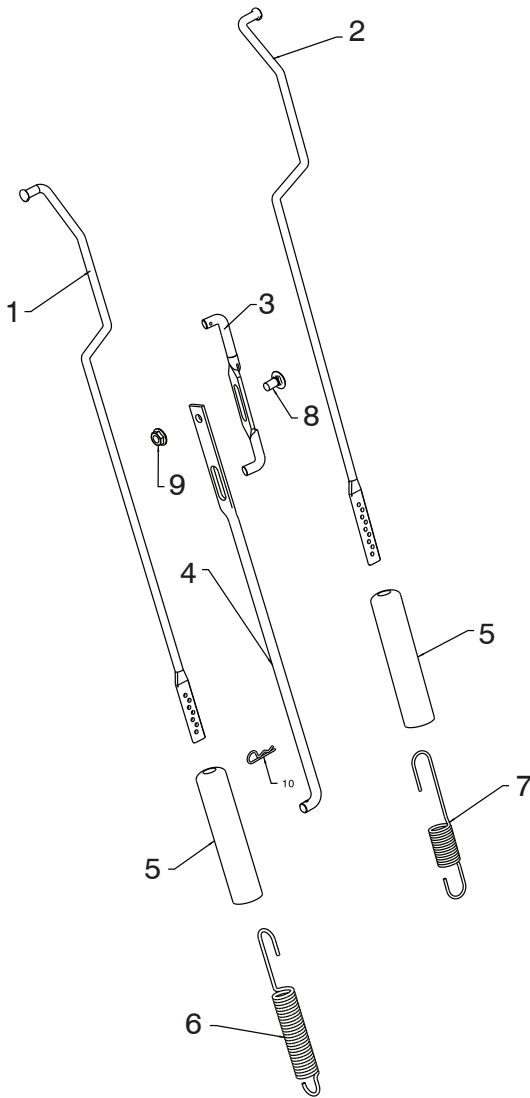

01.12.014-B

KEY NO.	PART NO.	DESCRIPTION
1	584 80 87-01	ROD IMPELLER CONTROL
2	584 80 88-01	ROD TRACTION CONTROL
3	532 42 55-98	SHIFTER ROD TOP
4	532 18 77-84	SHIFTER ROD BOTTOM
5	532 18 04-47	SPRING SLEEVE
6	580 79 62-01	SPRING CONTROL ROD
7	580 80 21-01	SPRING TRACTION ROD
8	872 27 05-05	CARRIAGE BOLT 5/16-18 X .75
9	532 15 53-77	NUT 5/16-18

NOTE: HOOK TRACTION ROD SPRING IN HOLE 3
HOOK IMPELLER ROD SPRING IN HOLE 4

NOTE: All component dimensions given in U.S. inches. 1 inch = 25.4 mm
IMPORTANT: Use only Original Equipment Manufacturer (O.E.M.) replacement parts.
Failure to do so could be hazardous, damage your snow thrower and void your warranty.

REPAIR PARTS

HANDLES

SNOW THROWER - MODEL NO. 1650EXL (96193008703), PRODUCT NO. 961 93 00-87

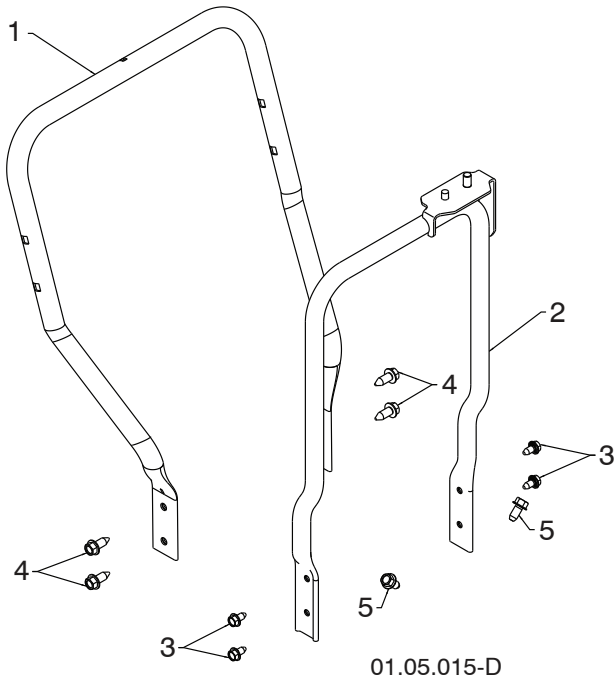

KEY NO.	PART NO.	DESCRIPTION
1	585 23 81-03	LOWER HANDLE
2	532 44 36-17	PIVOT SUPPORT WELDMENT
3	817 00 05-10	SCREW 5/16-18 X .750
4	817 00 06-16	SCREW 3/8-16 X 1.00
5	817 00 06-12	SCREW 3/8-16 X .750

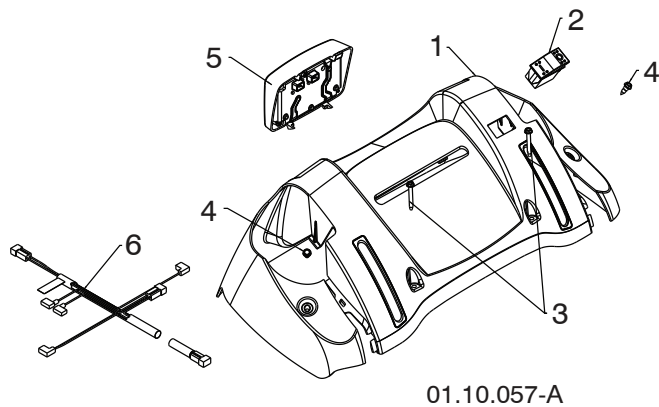

KEY NO.	PART NO.	DESCRIPTION
1	532 42 13-51	CONSOLE PANEL
2	532 41 77-60	SWITCH GRIP
3	532 17 52-62	SCREW HX WHSR HEAD 10-24 X 1.25
4	532 18 44-71	SCREW SHOULDER 10-24 X .62
5	581 68 42-01	LED LIGHT DUAL STAGE GRAY
6	580 62 56-02	WIRE HARNESS FLOOD / LED HEATED

NOTE: All component dimensions given in U.S. inches. 1 inch = 25.4 mm
IMPORTANT: Use only Original Equipment Manufacturer (O.E.M.) replacement parts.
 Failure to do so could be hazardous, damage your snow thrower and void your warranty.

REPAIR PARTS

DRIVE

SNOW THROWER - MODEL NO. **1650EXL** (96193008703), PRODUCT NO. 961 93 00-87

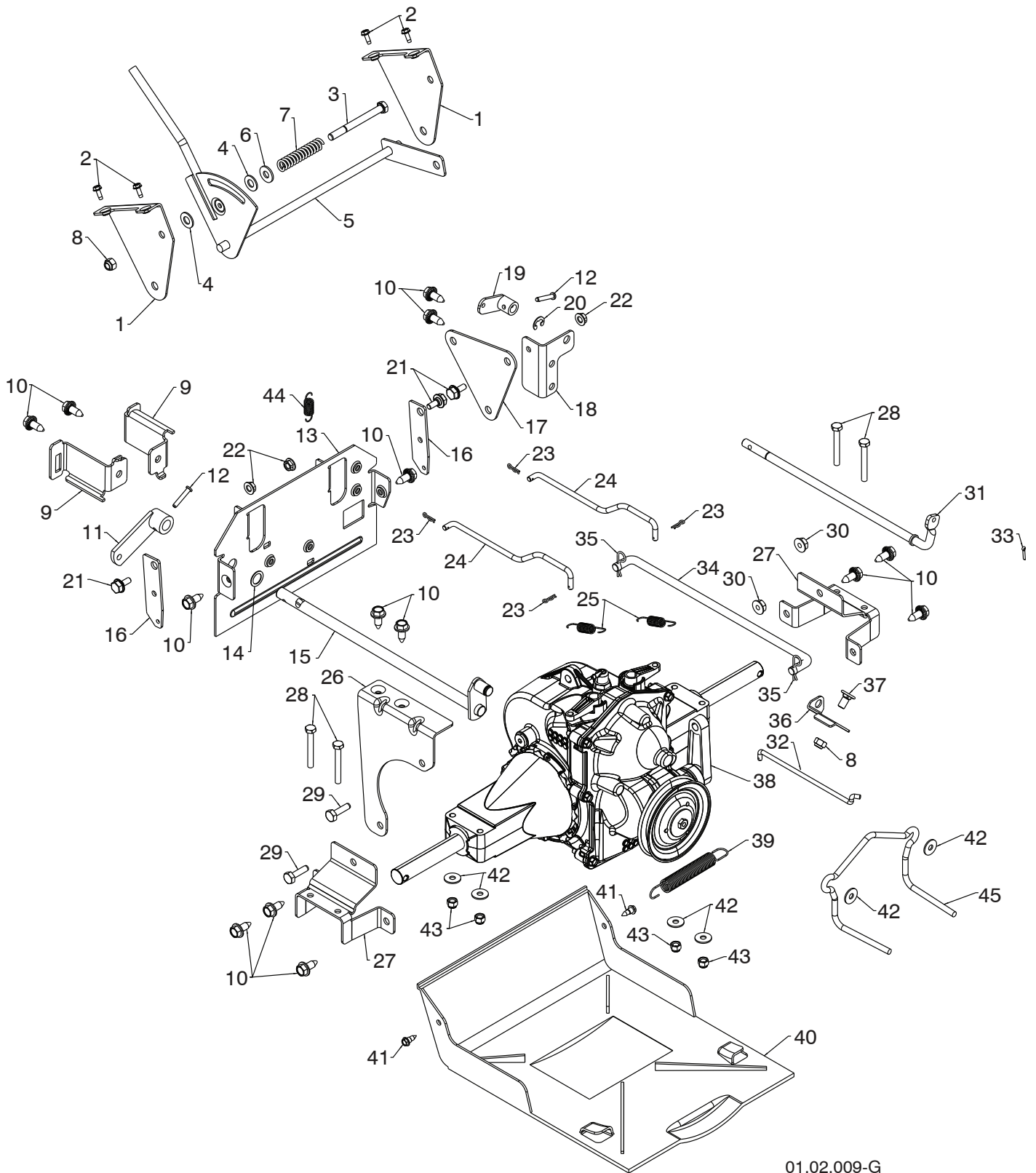

01.02.009-G

NOTE: All component dimensions given in U.S. inches. 1 inch = 25.4 mm
IMPORTANT: Use only Original Equipment Manufacturer (O.E.M.) replacement parts.
Failure to do so could be hazardous, damage your snow thrower and void your warranty.

REPAIR PARTS**DRIVE****SNOW THROWER - MODEL NO. 1650EXL (96193008703), PRODUCT NO. 961 93 00-87**

KEY NO.	PART NO.	DESCRIPTION	KEY NO.	PART NO.	DESCRIPTION
1	532 19 20-02	SHIFT BRACKET	24	532 42 54-96	STEER ROD
2	817 54 10-08	THREAD ROLLING SCREW 10-24 X .500	25	532 19 41-24	RETURN SPRING
3	874 76 05-52	SCREW 5/16-18 X 3.25	26	532 42 54-10	STABILIZER BRACKET
4	532 17 92-46	PLASTIC WASHER	27	532 42 54-09	TRANSMISSION MOUNTING BRACKET
5	532 42 55-96	SHIFT ASSEMBLY	28	874 88 04-32	SCREW 1/4-20 X 2.00
6	532 15 54-15	WASHER	29	874 76 05-16	BOLT 5/16-18 X 1.00
7	532 19 21-95	FRICTION SPRING	30	532 75 11-53	NUT 5/16-18 TOP LOCK
8	873 80 05-00	NUT 5/16-18 LOCK	31	532 19 82-51	CLUTCH SHAFT
9	532 42 79-44	CABLE MOUNTING BRACKET RH	32	532 44 62-93	CLUTCH ROD
10	532 42 88-67	SCREW 5/16-18 X .750	33	532 70 02-79	RETAINER CLIP
11	532 40 54-85	CONTROL ARM	34	532 42 54-99	SPEED CONTROL ROD
12	532 19 85-80	CLEVIS PIN	35	532 16 96-75	HAIRPIN RETAINER LARGE
13	532 42 54-11	REAR PLATE	36	532 19 82-47	FRONT CLUTCH BRACKET
14	532 05 70-79	WASHER	37	532 18 03-55	CARRIAGE BOLT 5/16-18 X .625
15	532 42 75-42	CONTROL SHAFT	38	532 42 53-94	HYDROSTATIC TRANSMISSION
16	532 42 55-34	STEER LEVER	39	532 17 88-28	BRAKE SPRING
17	532 42 55-45	PIVOT PLATE	40	532 42 54-98	BOTTOM PAN
18	532 42 55-43	REAR CLUTCH BRACKET	41	532 18 44-71	SHOULDER SCREW 10-24
19	532 19 82-49	CLUTCH ARM	42	532 05 38-47	WASHER
20	532 42 82-88	E-RING .375	43	873 80 04-00	NUT 1/4-20 NYLOCK
21	532 40 28-81	SHOULDER BOLT 1/4-20	44	532 40 65-58	RETURN SPRING
22	532 19 17-30	NUT 1/4-20 SIDELOCK	45	584 99 45-01	BELT GUIDE HYDRO 2
23	532 06 53-22	HAIRPIN RETAINER SMALL			

NOTE: All component dimensions given in U.S. inches. 1 inch = 25.4 mm
IMPORTANT: Use only Original Equipment Manufacturer (O.E.M.) replacement parts.
 Failure to do so could be hazardous, damage your snow thrower and void your warranty.

REPAIR PARTS

DRIVE

SNOW THROWER - MODEL NO. **1650EXL** (96193008703), PRODUCT NO. 961 93 00-87

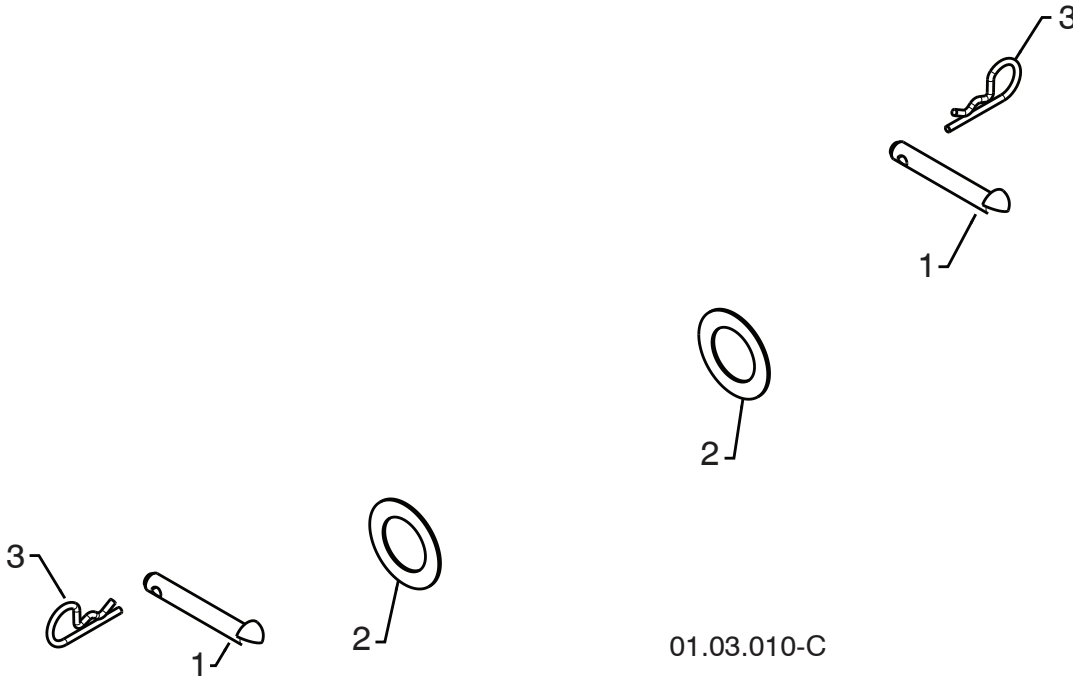

01.03.010-C

KEY NO.	PART NO.	DESCRIPTION
1	532 17 12-71	RIVET
2	532 12 49-31	THRUST WASHER
3	532 12 47-88	RETAINER

NOTE: All component dimensions given in U.S. inches. 1 inch = 25.4 mm
IMPORTANT: Use only Original Equipment Manufacturer (O.E.M.) replacement parts. Failure to do so could be hazardous, damage your snow thrower and void your warranty.

REPAIR PARTS

CHASSIS / PULLEYS

SNOW THROWER - MODEL NO. 1650EXL (96193008703), PRODUCT NO. 961 93 00-87

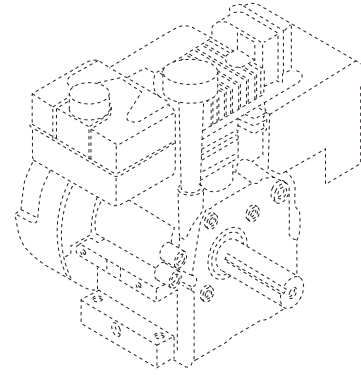
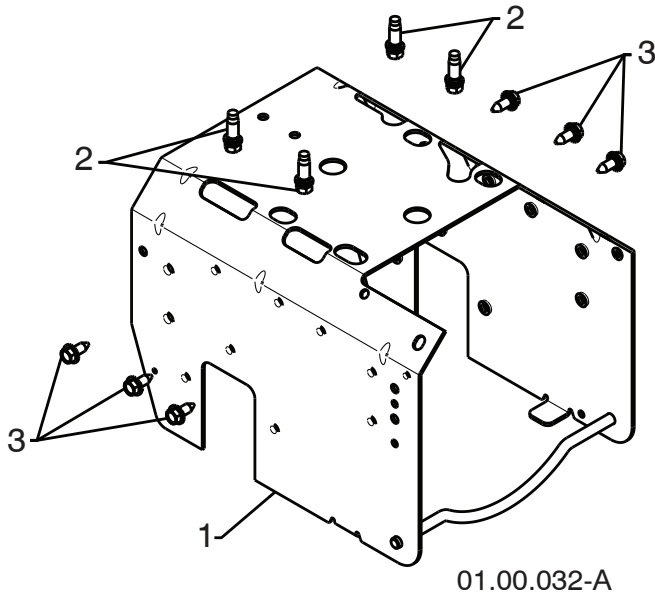

KEY NO.	PART NO.	DESCRIPTION
--	-----	B&S ENGINE MODEL 21M307-0135-F1
1	532 43 71-41	FRAME
2	532 15 04-06	BOLT 3/8-16
3	532 42 88-67	SCREW 5/16-18 X .750

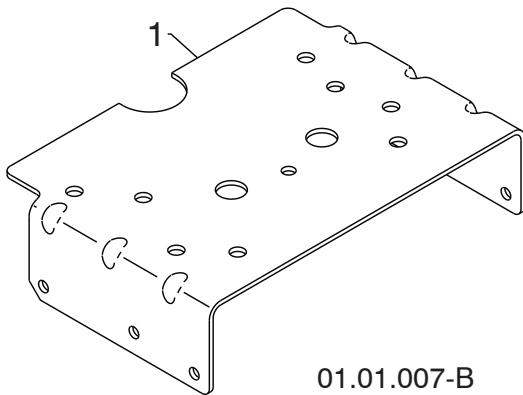

KEY NO.	PART NO.	DESCRIPTION
1	532 43 63-11	ENGINE MOUNT PLATE

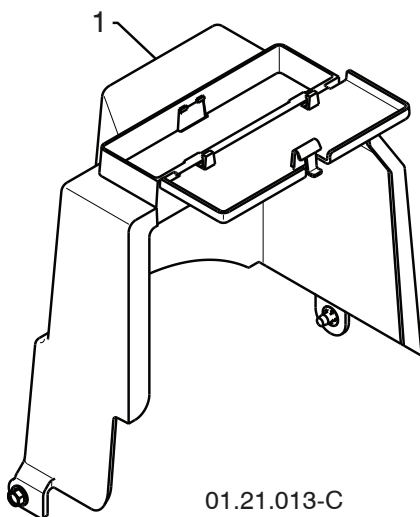

KEY NO.	PART NO.	DESCRIPTION
1	532 44 30-30	COVER ASSEMBLY

NOTE: All component dimensions given in U.S. inches. 1 inch = 25.4 mm
IMPORTANT: Use only Original Equipment Manufacturer (O.E.M.) replacement parts. Failure to do so could be hazardous, damage your snow thrower and void your warranty.

REPAIR PARTS

CHASSIS / PULLEYS

SNOW THROWER - MODEL NO. **1650EXL** (96193008703), PRODUCT NO. 961 93 00-87

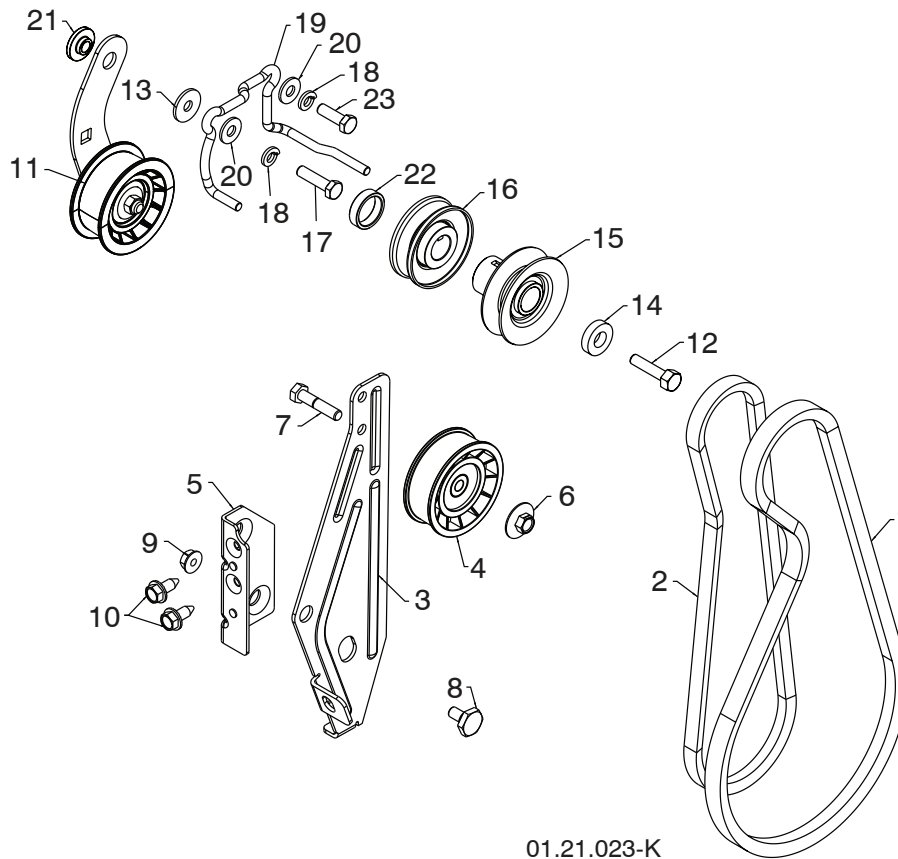

01.21.023-K

KEY NO.	PART NO.	DESCRIPTION	KEY NO.	PART NO.	DESCRIPTION
1	532 40 80-07	IMPELLER BELT	12	532 85 10-84	SCREW 3/8-24 X 1.375
2	532 44 81-83	TRACTION BELT	13	532 05 92-89	WASHER
3	584 23 24-02	IDLER ARM BRACKET	14	532 40 00-26	WASHER
4	532 18 05-23	IDLER PULLEY	15	532 42 64-91	PULLEY ENG IMPELLER
5	585 28 49-01	IDLER BRACKET	16	532 18 04-78	PULLEY ENG TRACTION
6	532 42 65-89	NUT 5/16-18	17	874 61 05-20	SCREW 5/16-24 X 1.25
7	874 78 05-24	SCREW 5/16-18 X 1.50	18	810 04 05-00	LOCKWASHER 5/16
8	532 42 42-97	SHOULDER BOLT 5/16-18 X .50	19	585 05 35-01	BELT GUIDE
9	532 75 11-53	NUT 5/16-18 LOCK	20	532 15 54-15	WASHER .20 X 8.5 X 2.0
10	817 00 05-10	SCREW 5/16-18 X 1.0 HEX WHS HD	21	532 17 53-31	IDLER BUSHING
11	585 23 84-01	TRACTION IDLER BRACKET ASM	22	532 40 94-75	SPACER
			23	874 61 05-16	SCREW 5/1-24 X 1.0 HEX

NOTE: All component dimensions given in U.S. inches. 1 inch = 25.4 mm
IMPORTANT: Use only Original Equipment Manufacturer (O.E.M.) replacement parts.
 Failure to do so could be hazardous, damage your snow thrower and void your warranty.

REPAIR PARTS

WHEELS

SNOW THROWER - MODEL NO. **1650EXL** (96193008703), PRODUCT NO. 961 93 00-87

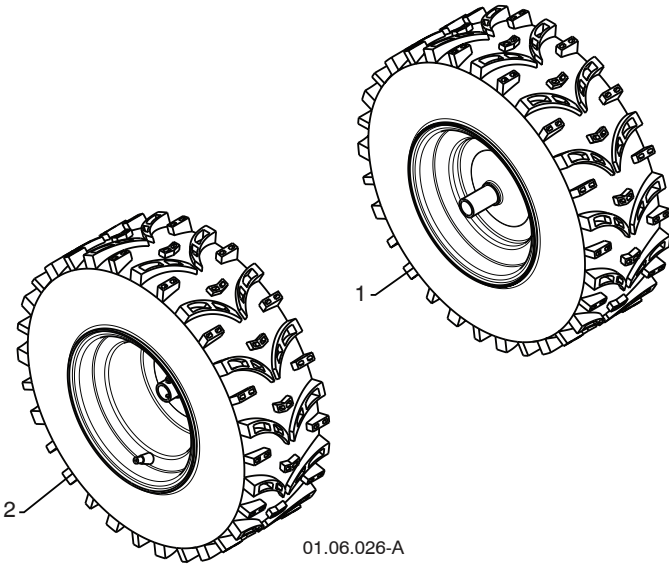

KEY NO.	PART NO.	DESCRIPTION
1	532 43 71-45	WHEEL ASSEMBLY LH
2	532 43 71-46	WHEEL ASSEMBLY RH

NOTE: All component dimensions given in U.S. inches. 1 inch = 25.4 mm
IMPORTANT: Use only Original Equipment Manufacturer (O.E.M.) replacement parts.
Failure to do so could be hazardous, damage your snow thrower and void your warranty.

REPAIR PARTS

BAG OF PARTS

SNOW THROWER - MODEL NO. **1650EXL** (96193008703), PRODUCT NO. 961 93 00-87

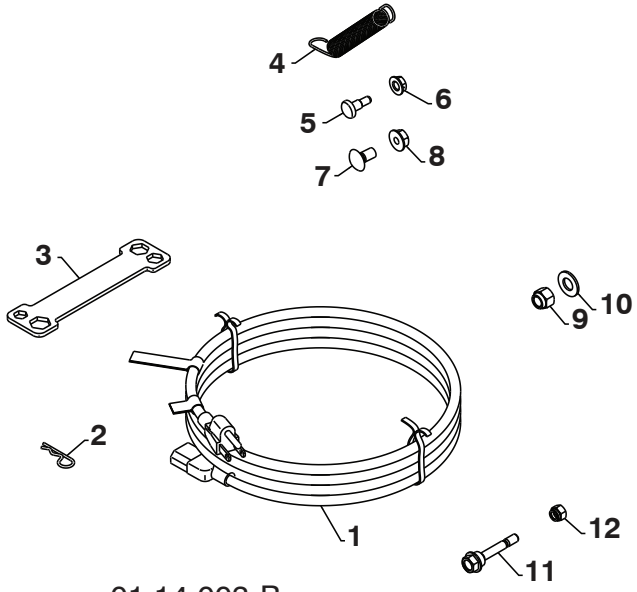

01.14.003-B

KEY NO.	PART NO.	DESCRIPTION
1	532 19 85-63	POWER CORD
2	532 16 96-75	RETAINER PIN
3	532 42 91-12	WRENCH
4	532 18 45-05	REMOTE SPRING
5	532 17 98-29	SHOULDER BOLT 1/4-20
6	532 19 17-30	LOCKNUT 1/4-20
7	872 25 05-05	CARRIAGE BOLT 5/16-18 X 5/8
8	532 75 11-53	LOCKNUT 5/16-18
9	873 80 06-00	LOCKNUT 3/8-16
10	819 13 13-16	WASHER 3/8
11	532 19 20-90	SHEAR BOLT 1/4-20 X 1-13/16
12	873 80 04-00	LOCKNUT 1/4-20

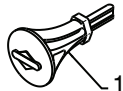

01.14.007-A

KEY NO.	PART NO.	DESCRIPTION
1	532 19 30-71	SAFETY IGNITION KEY

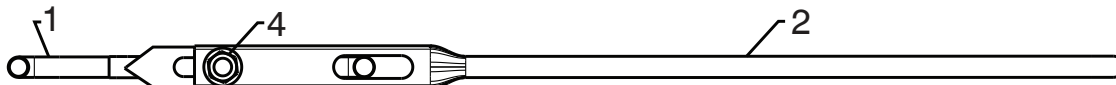
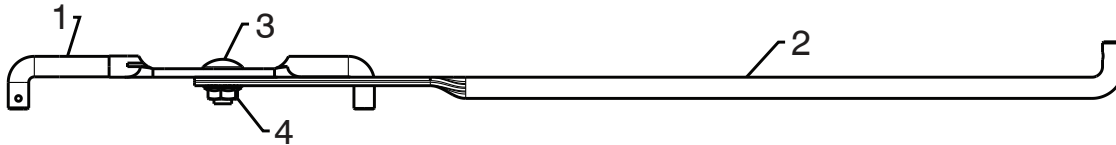

01.14.015-B

KEY NO.	PART NO.	DESCRIPTION
1	532 42 55-98	SHIFTER ROD TOP
2	532 18 77-84	SHIFTER ROD BOTTOM
3	872 27 05-05	CARRIAGE BOLT 5/16-18 X .75
4	532 15 53-77	NUT 5/16-18

NOTE: All component dimensions given in U.S. inches. 1 inch = 25.4 mm
IMPORTANT: Use only Original Equipment Manufacturer (O.E.M.) replacement parts. Failure to do so could be hazardous, damage your snow thrower and void your warranty.

REPAIR PARTS

DECALS

SNOW THROWER - MODEL NO. 1650EXL (96193008703), PRODUCT NO. 961 93 00-87

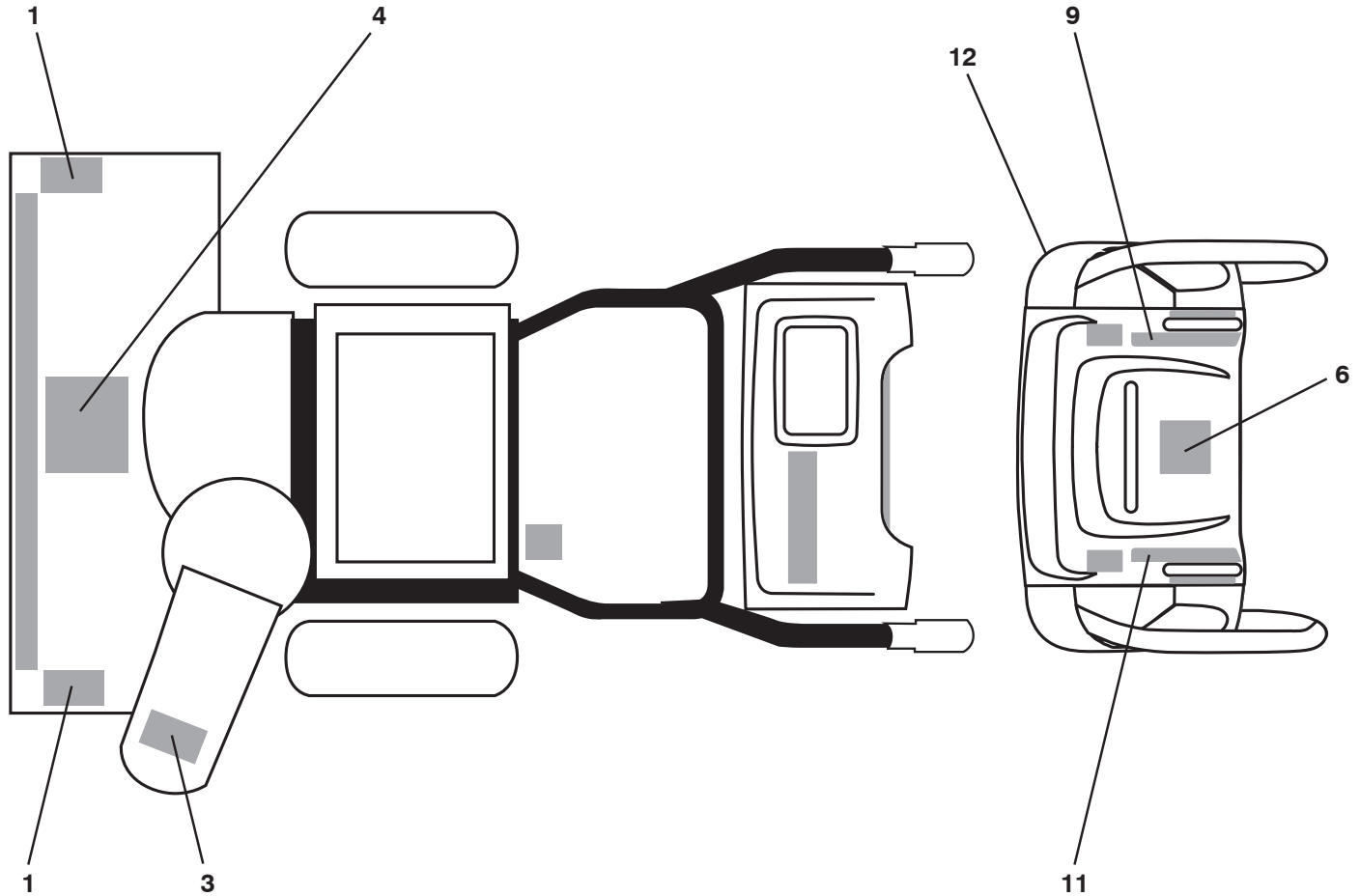

KEY NO.	PART NO.	DESCRIPTION
1	532 18 10-37	DECAL, DANGER
3	532 18 10-35	DECAL, DANGER, DEFLECTOR
4	532 18 10-42	DECAL, DANGER
6	532 42 95-73	DECAL, INSTRUCTION
9	581 43 01-04	DECAL, RH TRIGGER
11	581 43 01-05	DECAL, LH TRIGGER
12	532 44 47-68	DECAL, HANDWARMER
--	115 61 53-27	OPERATOR'S MANUAL, ENGLISH
--	115 61 54-32	OPERATOR'S MANUAL, FRENCH

NOTE: All component dimensions given in U.S. inches. 1 inch = 25.4 mm
IMPORTANT: Use only Original Equipment Manufacturer (O.E.M.) replacement parts. Failure to do so could be hazardous, damage your snow thrower and void your warranty.

