

Repair Parts Manual Manual De Repuestos

YT42XLS/96043015400/01

Please read the operator's manual carefully and make sure you understand the instructions before using the machine.

Por favor lea cuidadosamente y comprenda estas intrucciones antes de usar esta maquina.



English/Spanish

581 56 53-49 Rev. 5



HOW TO USE THIS MANUAL

This manual is designed to provide the customer with a means to identify the parts on his/her tractor when ordering repair parts. The illustrations may or may not represent the actual assemblies; therefore, it is not recommended to use this manual as a guide to assemble or disassemble the tractor. Some hardware and parts are drawn larger in order to more readily identify them.

Each tractor has its own model number.

The model number for your tractor can be found on the fender under the seat.

When ordering parts, always give the following information:

- Product - "TRACTOR"
- MODEL NUMBER - "YT42XLS" (96043015400/01)"
- Part Number
- Part Description

TABLE OF CONTENTS

SCHEMATIC	3
ELECTRICAL.....	4-5
CHASSIS	6-7
DRIVE.....	8-9
ENGINE.....	10-11
STEERING	12-13
MOWER DECK.....	14-15
MOWER LIFT.....	16
SEAT	17
DECALS.....	18

COMO UTILIZAR ESTE MANUAL

Este manual está diseñado para brindarle al comprador un medio para identificar las piezas del tractor para cuando necesite hacer el pedido de un repuesto. Las ilustraciones pueden o no representar los ensambles reales; por lo tanto, no se recomienda utilizar este manual como una guía para ensamblar o desarmar el tractor. Algunos accesorios y piezas están dibujados en tamaños más grandes para identificarlos con mayor facilidad.

Cada tractor tiene su propio número de modelo.

El número de modelo del tractor se encuentra en el guardabarros debajo del asiento.

Cuando haga el pedido de una pieza, siempre brinde la siguiente información:

- Producto: "TRACTOR"
- NÚMERO DE MODELO: "YT42XLS" (96043015400/01)"
- Número de pieza
- Descripción de la pieza

ÍNDICE

DIAGRAMA.....	19
DIAGRAMA ELÉCTRICO	20-21
CHASIS.....	22-23
TRANSMISIÓN	24-25
MOTOR.....	26-27
DIRECCIÓN	28-29
PLATAFORMA DE LA CORTADORA DE CÉSPED.....	30-31
ELEVACIÓN DE LA CORTADORA DE CÉSPED.....	32
ASIENTO.....	33
CALCOMANÍAS.....	34

TRACTOR - MODEL NO. YT42XLS (96043015400/01), PRODUCT NO. 960 43 01-54 SCHEMATIC

SCH12

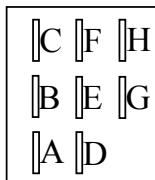
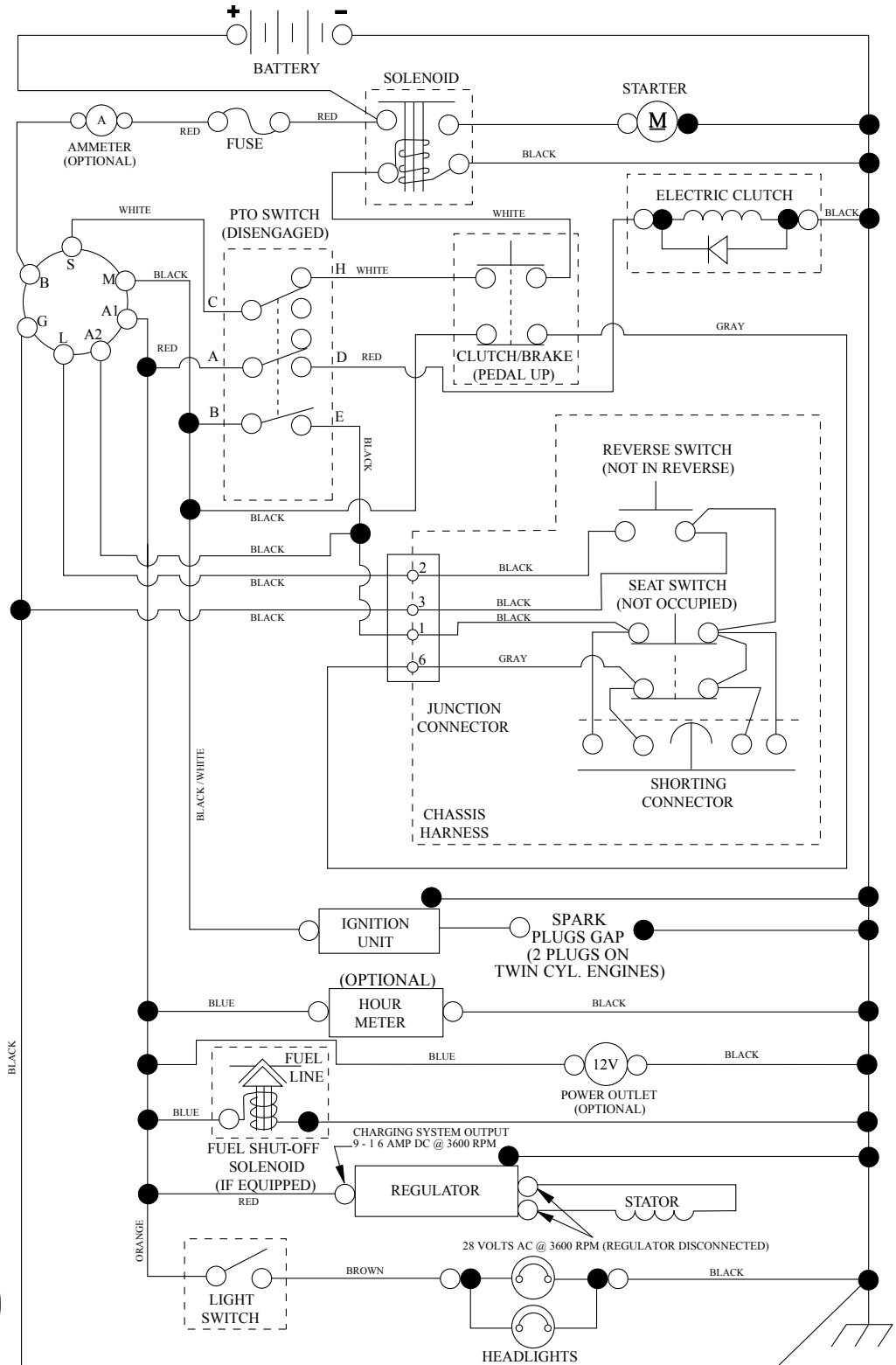

PTO SWITCH (MATING SIDE)

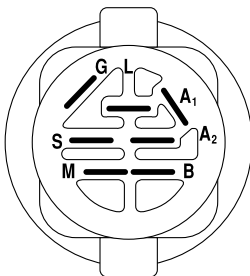

POSITION	CIRCUIT	"MAKE"
OFF	M+G+A1	
RUN/OVERRIDE	B+A1	
RUN	B+A1	L+A2
START	B+S+A1	

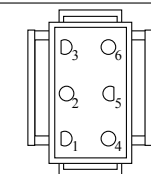

CHASSIS HARNESS CONNECTOR (MATING SIDE)

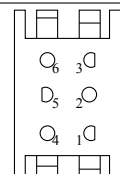

DASH HARNESS CONNECTOR

WIRING INSULATED CLIPS
NOTE: IF WIRING INSULATED CLIPS WERE REMOVED FOR SERVICING OF UNIT, THEY SHOULD BE RE-INSTALLED TO PROPERLY SECURE YOUR WIRING.

●
NON-REMOVABLE CONNECTIONS

○
REMOVABLE CONNECTIONS

**TRACTOR - MODEL NO. YT42XLS (96043015400/01), PRODUCT NO. 960 43 01-54
ELECTRICAL**

T15S

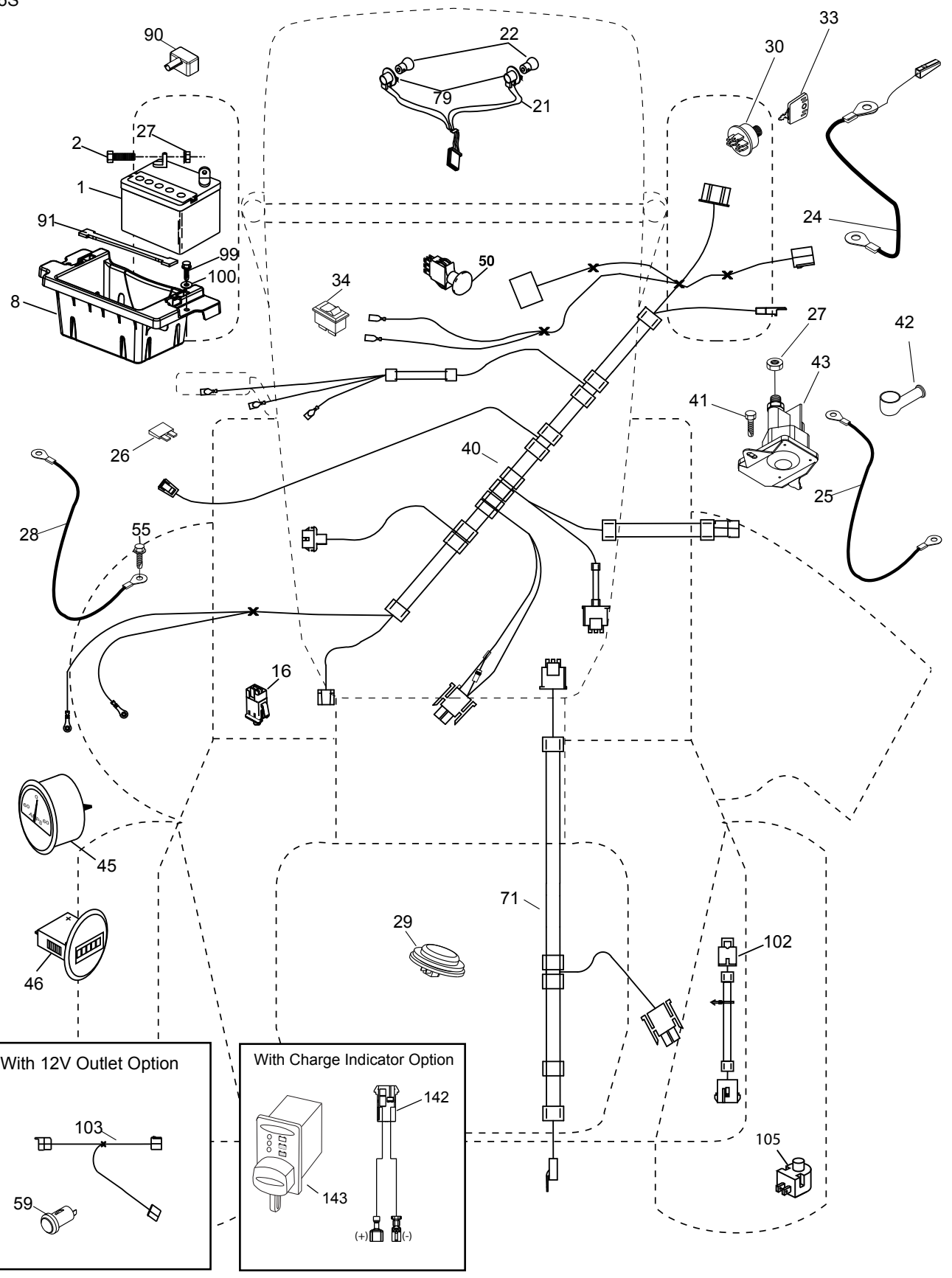

**TRACTOR - MODEL NO. YT42XLS (96043015400/01), PRODUCT NO. 960 43 01-54
ELECTRICAL**

KEY NO.	PART NO.	DESCRIPTION
1	532 16 34-65	Battery
2	874 76 04-12	Bolt Hex Head 1/4-20 x 3/4
8	532 41 41-26	Box Battery
16	532 17 61-38	Switch Interlock Push-In
21	532 40 02-52	Harness Socket Light w/4152J
22	532 00 41-52	Bulb Light
24	532 40 02-53	Cable Battery 8"
25	532 41 28-95	Cable Starter
26	532 17 51-58	Fuse
27	873 51 04-00	Nut Keps Hex 1/4-20 unc
28	532 14 54-91	Cable, Ground
29	532 40 15-45	Switch, Seat
30	532 19 33-50	Switch, Ign
33	532 41 19-33	Key/Chain
34	532 11 07-12	Switch Light / Reset
40	581 58 35-01	Harness Ign. Dash
41	817 72 04-08	Screw Thd Cut 1/4-20 x 1/2
42	532 13 15-63	Cover, Terminal
43	532 19 25-07	Solenoid
45	532 42 52-70	Ammeter Gauge Round Snap-In
46	532 42 52-71	Gauge Hrmtr
50	532 17 46-51	Switch PTO
55	817 06 05-12	Screw Thdrol 5/16-18 x 3/4 TYTT
59	532 40 03-03	Outlet 12-Volt
71	532 19 42-76	Harness Ign. / Chassis
79	532 17 52-42	Socket Asm Bulb Twistlock
90	532 43 53-95	Cover Terminal
91	532 19 02-70	Strap Battery Mount Front
99	817 67 04-12	Screw Hexwsh Thdrol 1/4-20 x 3/4
100	819 09 14-16	Washer 9/32 x 7/8 x 16 Ga.
102	532 40 44-54	Harness Pigtail
103	532 42 17-47	Harness 12-Volt Pigtail
105	532 40 75-68	Switch Reverse TT Pedal Control
142	583 85 78-01	Harness Charge Port
143	532 44 80-59	Charge Port

NOTE: All component dimensions given in U.S. inches
1 inch = 25.4 mm

**TRACTOR - MODEL NO. YT42XLS (96043015400/01), PRODUCT NO. 960 43 01-54
CHASSIS**

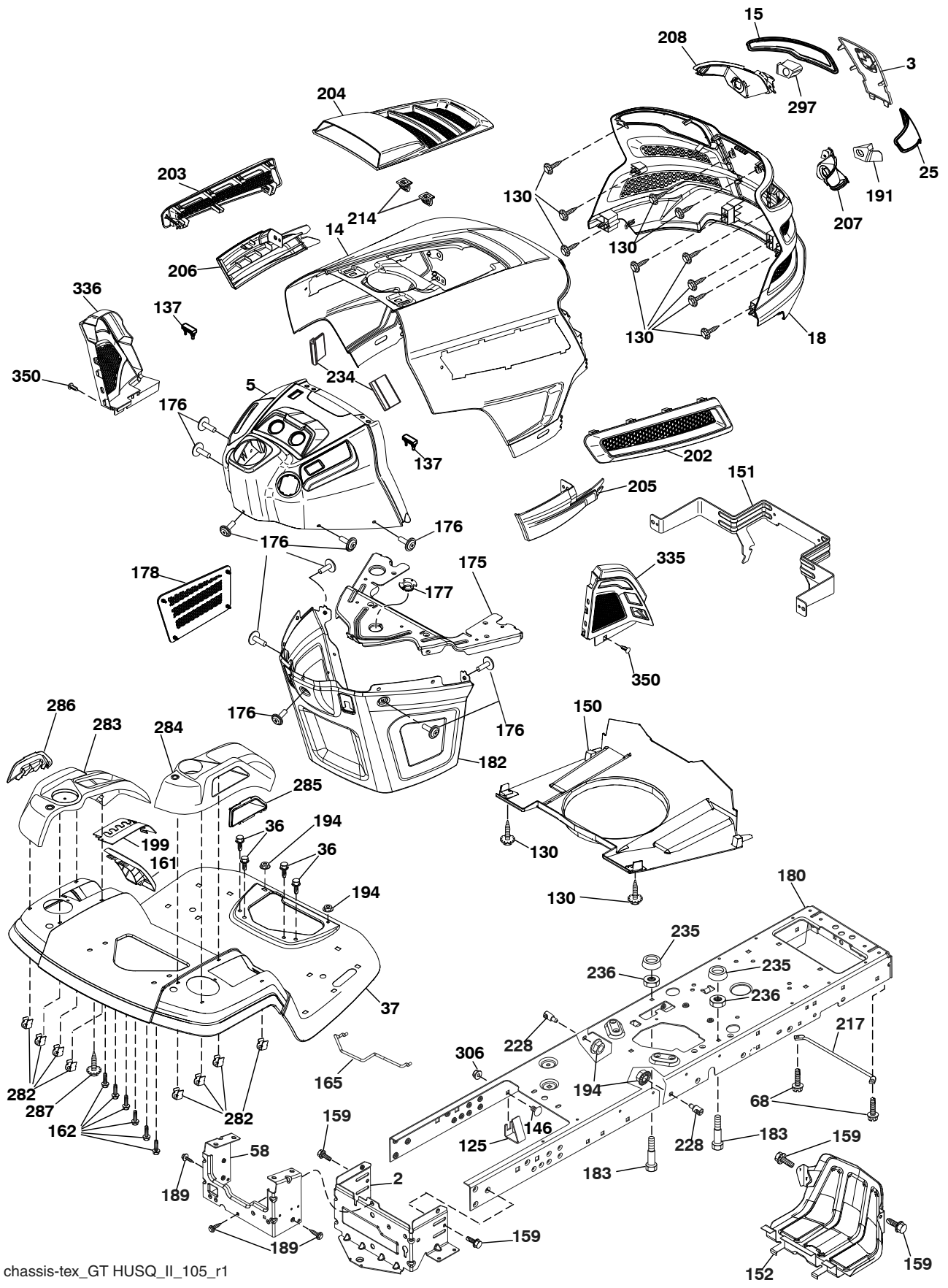

chassis-tex_GT HUSQ_II_105_r1

**TRACTOR - MODEL NO. YT42XLS (96043015400/01), PRODUCT NO. 960 43 01-54
CHASSIS**

KEY NO.	PART NO.	DESCRIPTION	KEY NO.	PART NO.	DESCRIPTION
2	532 41 22-82	Drawbar	194	873 90 05-00	Nut Lock Hex Flange 5/16-18
3	532 44 44-81	Trim, Husq.	199	532 41 34-85	Plate Deck Lift
5	532 43 74-90	Dash	202	532 43 97-28	Vent Side Hood RH
14	532 44 11-77	Hood	203	532 43 97-27	Vent Side Hood LH
15	532 43 97-33	Lens LH	204	532 43 57-14	Vent Top Hood
18	532 44 06-53	Grille	205	532 43 97-30	Skirt Hood Side RH
25	532 44 33-85	Lens RH	206	532 43 97-29	Skirt Hood Side LH
36	817 06 05-12	Screw 5/16-18 x 3/4	207	532 43 97-34	Bezel RH
37	532 44 11-78	Fender	208	532 43 97-35	Bezel LH
58	532 41 22-80	Drawbar Upper	214	532 19 91-45	Clip Retainer Tinner
68	817 49 05-08	Screw Thdrol 5/16-18 x 1/2	217	532 40 91-67	Rod Pivot
125	581 68 48-01	Clip Fuel Line	228	532 19 51-61	Stud Fastener
130	532 41 63-58	Screw 10 x 0.750 BOS Thread	234	532 40 47-42	Bumper Hood
137	532 40 75-90	Bumper Dash	235	532 40 61-29	Spacer Fender
146	581 85 79-01	Bolt	236	873 93 05-00	Nut Lock 5/16-18 unc
150	532 43 97-74	Air Duct	282	532 41 41-10	Clip Retainer Console
151	532 43 66-70	Pivot Bracket	283	532 43 98-23	Console Deck Lift
152	532 43 98-70	Shield Browning	284	532 43 98-61	Console Shift
159	817 00 06-12	Screw 3/8-16 x 3/4	285	532 41 63-15	Console Insert RH
161	532 43 97-81	Window Fuel	286	532 41 63-17	Console Insert LH
162	532 14 24-32	Screw Hex Wsh Hi-Lo 1/4x1/2unc	287	817 60 04-06	Screw 1/4-20 X 3/8
165	532 19 43-30	Support Tank Rear	297	532 43 74-56	Insert Reflective LH
175	532 19 63-04	Crossmember	306	873 90 06-00	Nut Lock
176	532 40 07-76	Screw 10-24 x 5/8	335	532 44 82-04	Cover RH
177	532 19 52-27	Bushing Steering	336	532 44 53-09	Cover LH
178	532 19 97-82	Cargo Net Asm.	350	532 44 51-43	Clip X-mas Tree
180	532 44 55-59	Chassis	--	532 44 80-86	Kit Guard Brush
182	532 40 68-59	Dash Lower			
183	874 52 05-20	Bolt 5/16-18 x 1-1/4			
189	817 00 05-12	Screw 5/16-18 x 3/4			
191	532 43 74-55	Insert Reflective RH			

NOTE: All component dimensions given in U.S. inches
1 inch = 25.4 mm

TRACTOR - MODEL NO. YT42XLS (96043015400/01), PRODUCT NO. 960 43 01-54 DRIVE

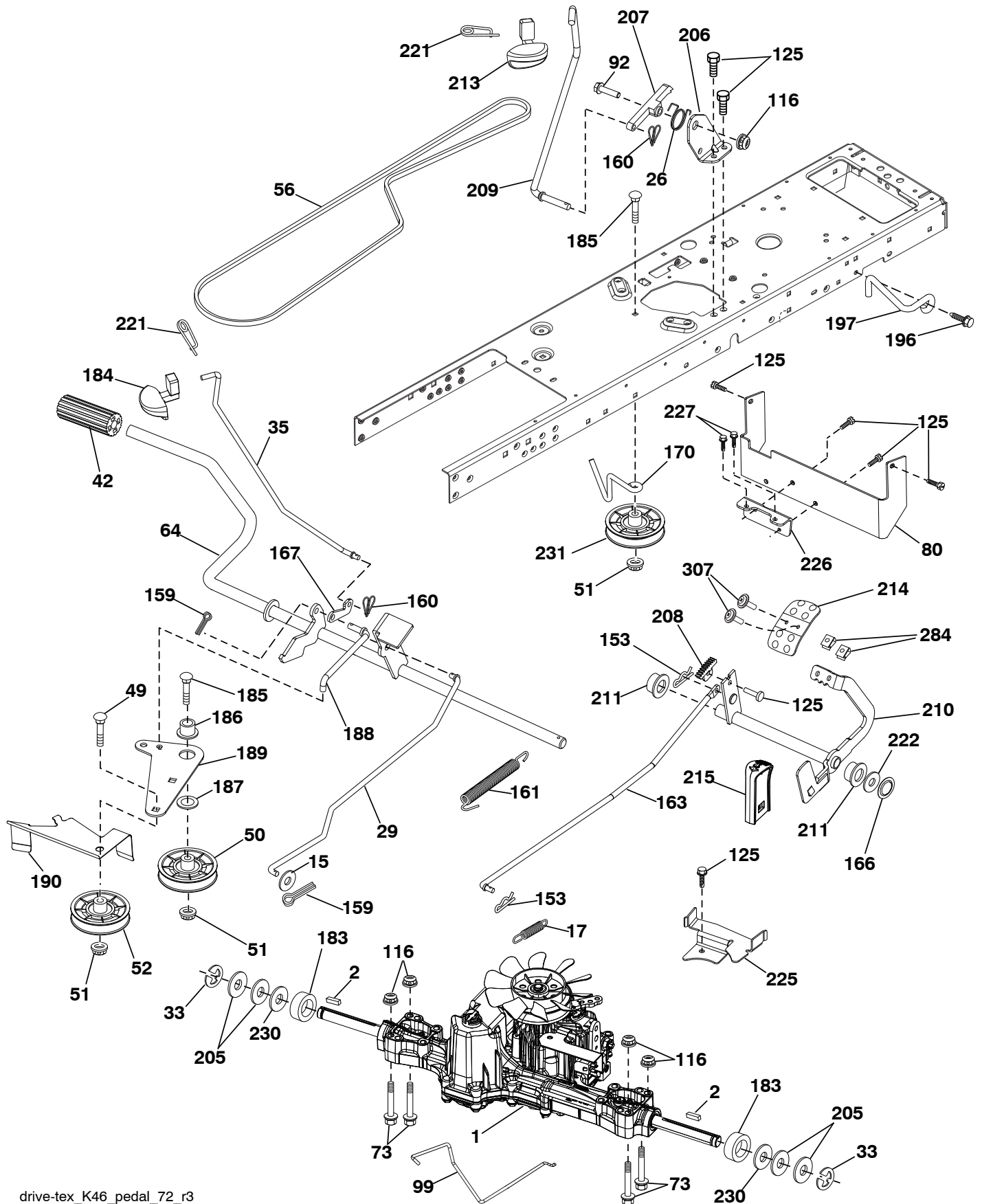

drive-tex_K46_pedal_72_r3

**TRACTOR - MODEL NO. YT42XLS (96043015400/01), PRODUCT NO. 960 43 01-54
DRIVE**

KEY NO.	PART NO.	DESCRIPTION	KEY NO.	PART NO.	DESCRIPTION
1	---	Transaxle, TUFFTORQ K46CR (426121) (Order parts from transaxle manufacturer)	184	532 44 14-55	Handle Parking Brake
2	532 12 35-83	Key	185	872 11 06-22	Bolt Rdhd Sqnk 3/8-16 x 2-1/2
15	819 13 13-16	Washer 13/32 x 13/16 x 16 Ga.	186	532 19 43-21	Spacer Retainer
17	532 41 36-78	Spring, Brake	187	819 13 32-10	Washer
26	532 19 96-79	Spring Return Cruise	188	532 19 43-23	Link Clutch Ground Drive
29	532 40 38-06	Rod, Brake	189	532 19 43-17	Bellcrank Ground Drive
33	812 00 00-01	Ring E	190	532 19 43-18	Keeper Bellcrank Ground Drive
35	583 86 45-01	Rod, Brake, Park	196	817 00 06-16	Screw 3/8-16 x 1
42	532 12 48-72	Cover, Foot Pedal	197	532 19 58-04	Bracket Clutch Anti-Rotation
49	872 11 06-14	Bolt	205	532 12 17-48	Washer
50	532 19 43-27	Pulley Idler Flat	206	532 19 78-67	Bracket Mount Latch Cruise
51	873 90 06-00	Lock Nut 3/8-16	207	532 19 78-68	Latch Control Cruise
52	532 19 43-26	Idler V-Groove 910" Offset	208	532 19 78-69	Gear Sector Control Cruise
56	532 13 09-69	V-Belt, Drive	209	532 19 95-92	Rod Control Cruise
64	532 19 78-65	Shaft Asm. Pedal Brake Control	210	532 40 09-80	Rocker Asm. Pedal Control
73	874 49 05-40	Bolt 5/16-18 x 1/2 Gr. 5	211	532 12 01-83	Bearing Nylon
80	532 44 06-19	Bracket Strap Torque	213	532 40 31-19	Knob Control Cruise
92	874 76 05-20	Bolt Fin Hex 5/16-18 unc x 1.25	214	532 41 68-63	Pedal Forward
99	532 41 57-42	Rod Spring Bypass	215	532 40 17-23	Pedal Reverse
116	873 90 05-00	Nut Lock Hex Flange 5/16-18	221	532 40 31-87	Retainer Spring Clip Handle
125	817 00 05-12	Screw 5/16-18 x 3/4	222	879 21 20-10	Washer 21/32 x 1-1/4 x 10 Ga.
153	532 12 47-88	Retainer Spring	225	532 40 33-19	Keeper Belt Trans.
159	876 02 04-12	Pin Cotter 1/8 x 3/4	226	532 40 15-64	Bracket Mount Torque
160	532 16 94-84	Retainer Clip	227	817 49 05-12	Screw 5/16-18 x 3/4
161	532 10 57-09	Spring, Return, Clutch	230	532 18 89-67	Washer Hardened
163	532 44 82-75	Rod Pedal Control	231	532 40 72-87	Idler Groove
166	532 42 91-64	Nut Push	284	532 41 76-93	Nut U-CHNL 1/4-20 550DP .350 PNL
167	532 40 52-57	Latch Brake Parking	307	874 18 04-12	Screw 1/4-20 x 3/4
170	532 41 34-30	Keeper Belt Centerspan			
183	532 13 70-57	Spacer Split			

NOTE: All component dimensions given in U.S. inches
1 inch = 25.4 mm

**TRACTOR - MODEL NO. YT42XLS (96043015400/01), PRODUCT NO. 960 43 01-54
ENGINE**

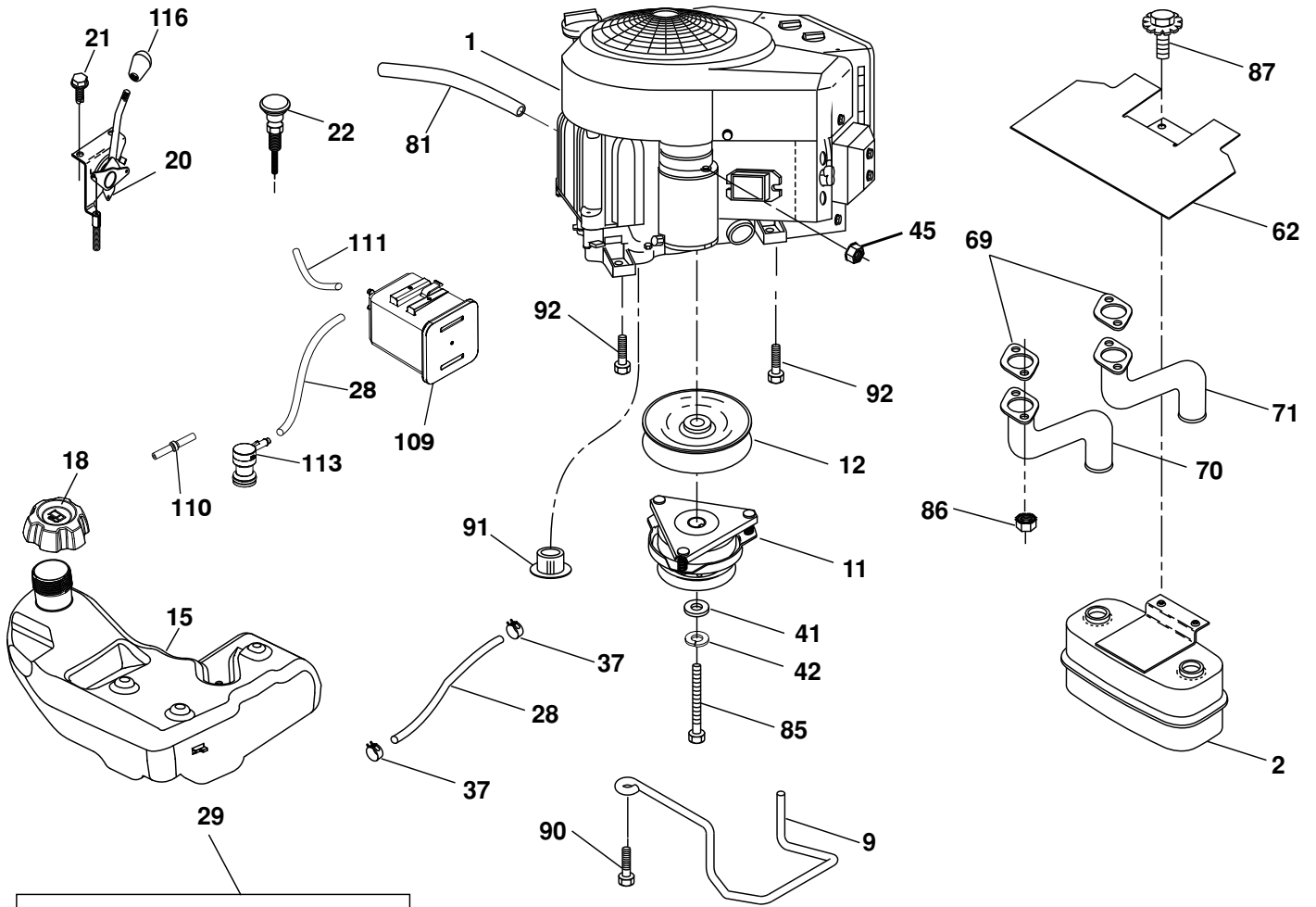

engine-tex_Kawa-2cyl_5_r1

**TRACTOR - MODEL NO. YT42XLS (96043015400/01), PRODUCT NO. 960 43 01-54
ENGINE**

KEY NO.	PART NO.	DESCRIPTION
1	-----	Engine Kawa Model No. FR691-ES15 (581557501) (Order parts from engine manufacturer)
2	532 44 59-62	Muffler
9	532 19 43-20	Keeper Belt Engine
11	532 40 00-08	Clutch Electric
12	532 40 50-97	Pulley Engine
15	532 41 41-51	Tank Fuel
18	532 43 92-08	Cap
20	532 42 43-41	Control Throttle
21	532 41 63-58	Screw #10 x .750 BOS Thread
22	532 18 95-41	Control Choke
28	532 40 11-35	Fuel Line
29	532 13 71-80	Spark Arrester Kit
37	532 12 34-87	Clamp Hose
41	532 12 61-97	Washer 1-1/2 OD x 15/32 ID x .250
42	810 04 07-00	Washer Lock 7/16
45	873 51 04-00	Nut Keps Hex 1/4-20 unc
62	532 43 40-17	Heat Shield
69	532 17 81-51	Gasket
70	583 95 56-01	Tube Exhaust LH
71	583 95 57-01	Tube Exhaust RH
81	532 14 84-56	Tube Drain Oil Easy
85	532 17 39-37	Bolt Hex 7/16-20 x 4 x Gr. 5-1.5 Thr
86	532 18 43-62	Nut Hex Flange Toplock M8-1.25
87	537 17 18-77	Bolt 5/16-18 unc x 3/4 w/Sems
90	817 00 06-16	Screw 3/8-16 x 1
91	532 18 74-95	Bushing 1.375 OD
92	817 12 06-16	Screw 3/8-16 x 1
109	532 41 41-14	Canister Carbon
110	532 41 41-18	Valve Asm.
111	532 41 41-19	Purge Line
113	532 41 41-27	Valve Slant
116	539 13 26-24	Knob Soft Touch

NOTE: All component dimensions given in U.S. inches
1 inch = 25.4 mm

For engine service and replacement parts, call the toll free number for your engine manufacturer listed below:

Kawasaki 1-949-460-5688

TRACTOR - MODEL NO. YT42XLS (96043015400/01), PRODUCT NO. 960 43 01-54
STEERING ASSEMBLY

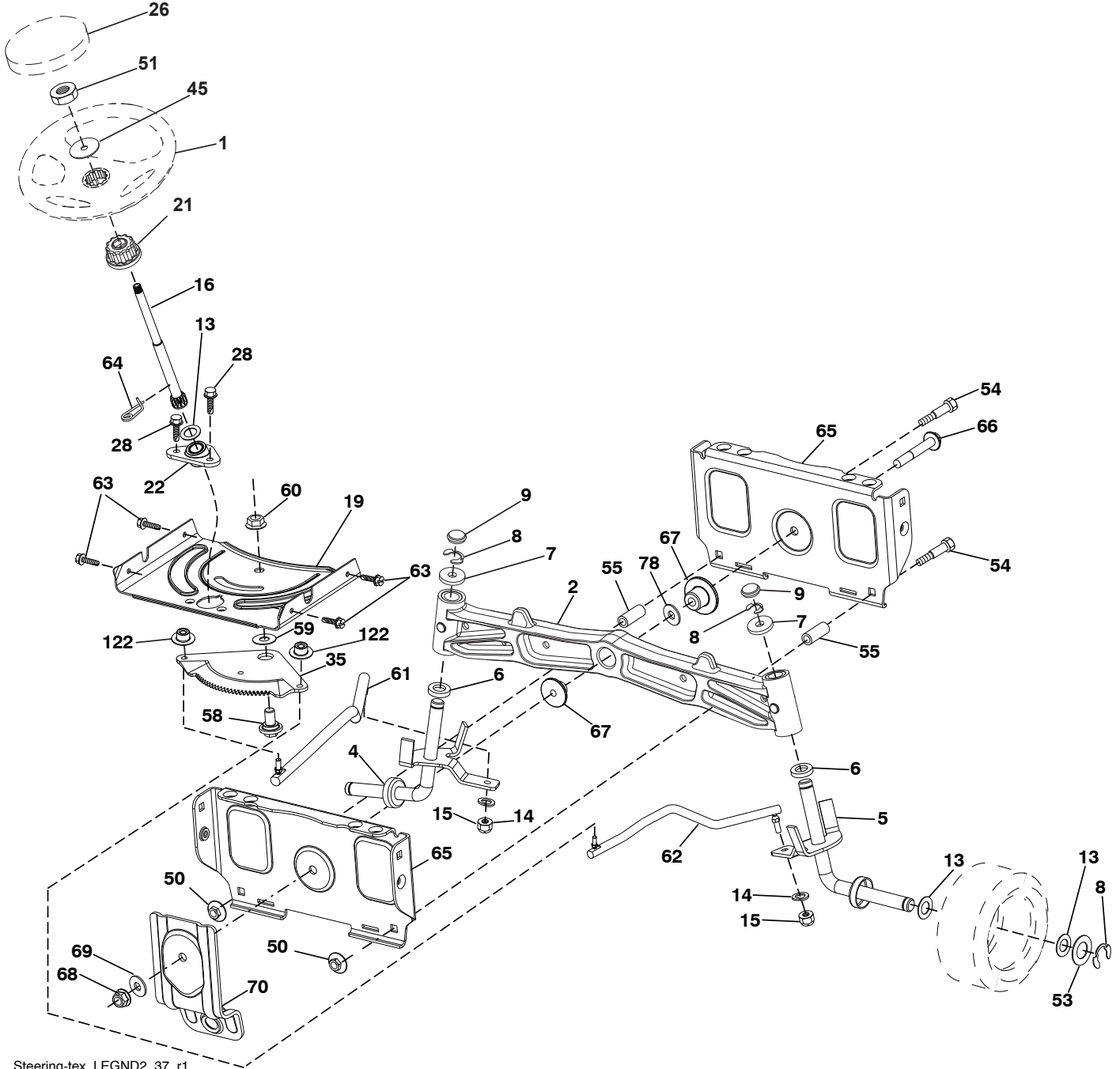

Steering-tex_LEGND2_37_r1

**TRACTOR - MODEL NO. YT42XLS (96043015400/01), PRODUCT NO. 960 43 01-54
STEERING ASSEMBLY**

KEY NO.	PART NO.	DESCRIPTION
1	532 43 97-40	Wheel, Steering
2	532 19 59-68	Axle Asm., Front
4	532 40 30-89	Spindle Asm., LH
5	532 40 30-90	Spindle Asm., RH
6	532 12 49-31	Bearing, Race Thrust Harden
7	532 12 17-48	Washer 25/32 x 1-5/8 x 16 Ga.
8	812 00 00-29	Ring, Clip #T5304-75
9	532 12 12-32	Cap, Spindle
13	532 12 17-49	Washer 25/32 x 1-1/4 x 16 Ga.
14	810 04 06-00	Washer, Lock Hvy Hlcl Spr 3/8
15	873 54 06-00	Nut, Crown Lock 3/8-24 unf
16	532 40 82-19	Shaft Steering
19	532 19 47-29	Plate Steering
21	532 18 67-37	Adapter, Wheel Steering
22	532 42 05-37	Steering Support Lower
26	532 43 97-43	Insert, Wheel Steering
28	817 00 06-12	Screw 3/8-16 x 3/4
35	532 19 47-32	Gear, Sector Plate
45	819 18 38-12	Washer 9/16 ID x 2-3/8 OD 12 Ga.
50	873 90 06-00	Nut Lock Flg. 3/8-16 unc
51	873 94 08-00	Nut Hex Jam Toplock 1/2-20 unf
53	532 18 89-67	WasherHardened.793x1.637x.060
54	874 76 06-36	Bolt Hex 3/8-16 unc x 2-1/4
55	532 41 47-36	Spacer Brace Axle
58	532 19 47-47	Bolt Shoulder Sector Pivot CFM
59	532 19 47-48	Washer Thrust Sector Steering
60	873 97 10-00	Nut Flange Lock 5/8-11
61	532 19 47-40	Draglink, LH
62	532 19 47-41	Draglink, RH
63	817 00 05-12	Screw 5/16-18 x 3/4
64	532 19 98-49	Retainer Clip Spring Steering
65	532 19 47-34	Brace Axle Front
66	871 02 07-48	Bolt Hex Fghd 7/16-14 x 3 Serr
67	532 19 47-37	Bushing PM Front Axle
68	873 90 07-00	Nut Lock Flange 7/16-14 Gr. 5
69	532 19 91-62	Washer 1.5 x .505 x .118
70	532 19 61-97	Bracket Deck Susp. Front
78	532 05 70-79	Washer Thrust
122	532 44 49-62	Cap Gear

NOTE: All component dimensions given in U.S. inches
1 inch = 25.4 mm

**TRACTOR - MODEL NO. YT42XLS (96043015400/01), PRODUCT NO. 960 43 01-54
MOWER DECK**

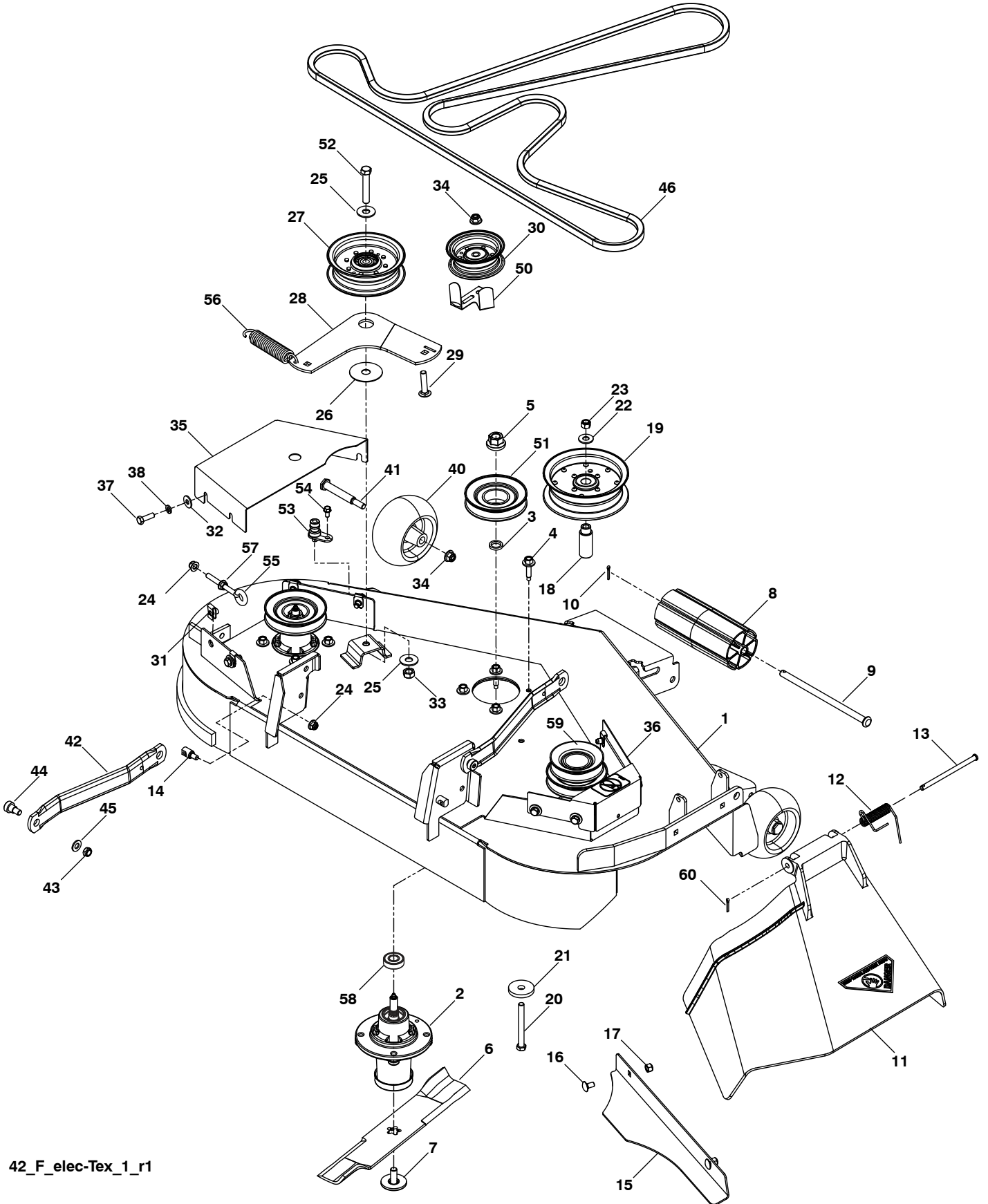

42_F_elec-TeX_1_r1

**TRACTOR - MODEL NO. YT42XLS (96043015400/01), PRODUCT NO. 960 43 01-54
MOWER DECK**

KEY NO.	PART NO.	DESCRIPTION	KEY NO.	PART NO.	DESCRIPTION
1	574 77 89-02	Deck Weldment	33	539 11 91-24	Nut, 7/16-14 Hex Nyloc
2	539 11 21-70	Housing Assembly	34	521 99 65-01	Nut 3/8-16 Hex Flg Nyloc
3	539 18 76-90	Washer-Spacer	35	575 22 47-02	Shield, Belt LH
4	532 17 39-84	Screw Thd Roll	36	575 96 71-02	Shield, Belt RH
5	539 40 02-34	Nut, 9/16 Top Center Lock	37	539 99 02-09	Hcs 5/16-18 x 1 Gr. 5
6	539 11 20-78	Blade, 14-5/8"	38	539 99 01-87	Wash 5/16 Slw
7	532 19 30-03	Bolt, 7/16, Assy Blade	40	532 13 39-57	Wheel, Gauge
8	532 17 60-66	Roller, Nose	41	539 19 34-06	Bolt, Shoulder
9	532 17 91-27	Rod, Roller, Nose	42	532 19 51-85	Arm, Susp., Rear
10	532 19 42-08	Clip Retainer	43	539 20 02-82	Nut, 3/8-16 Hex Jam Nyloc
11	539 11 07-31	Discharge Chute - 42" Plastic	44	539 11 36-21	Sb 3/8-16 x 3/8 Skt Hd
12	539 11 07-35	Spring - Torsion	45	539 99 01-22	Washer, 3/8 Sae Flt
13	539 11 07-36	Pin, Clevis 5/16 x 5.19	46	574 84 56-01	Belt, 42" Fab Deck
14	532 19 51-61	Stud, Fasten w/ Anti- Rotate	50	575 22 43-01	Guard, Belt
15	539 11 24-12	Confinement Plate	51	575 22 44-01	Pulley, Mandrel
16	539 99 07-99	Rhsnb 5/16-18 x 5/8 Gr. 5	52	539 10 48-70	Hcs 7/16-14 x 2-1/2 Gr. 5
17	539 99 07-17	Nut 5/16-18 Hex Nyloc	53	532 41 55-98	Washout Port
18	575 22 45-01	Idler Bushing	54	539 10 84-61	Bolt, 1/4-20 x 1/2
19	539 13 27-28	Pulley, Idler	55	539 11 55-74	Eyebolt 5/16 x 3-1/2
20	539 10 82-71	Hcs 3/8-16 x 3-1/2 Gr. 5	56	539 10 68-50	Spring
21	539 10 65-04	Heavy Washer	57	539 13 20-19	Nut 7/16-14 Hex
22	539 99 05-17	Washer, 3/8 Flat Std	58	532 11 04-85	Ball Bearing
23	539 97 69-79	Nut 3/8-16 Hex Nyloc	59	575 41 62-01	Pulley
24	539 11 28-99	Nut 5/16-18 Hex Flange Nyloc	60	532 16 94-84	Retainer Clip
25	539 10 48-64	Washer, 7/16 Flat	--	532 41 64-05	Connect Quick Coupling
26	532 17 85-15	Washer, Flat Hardened	--	532 44 53-57	Mower Deck Complete
27	532 19 61-04	Pulley, Idler Spec. Hub			
28	574 82 71-01	Arm, Idler, Blk			
29	539 99 09-23	Rhsnb 3/8-16 x 1-3/4 Gr. 5			
30	532 17 79-68	Pulley, Idler			
31	539 10 47-63	Retainer 5/16c U Type			
32	539 99 06-92	Washer, 5/16 Std Flt			

NOTE: All component dimensions given in U.S. inches
1 inch = 25.4 mm

**TRACTOR - MODEL NO. YT42XLS (96043015400/01), PRODUCT NO. 960 43 01-54
MOWER LIFT**

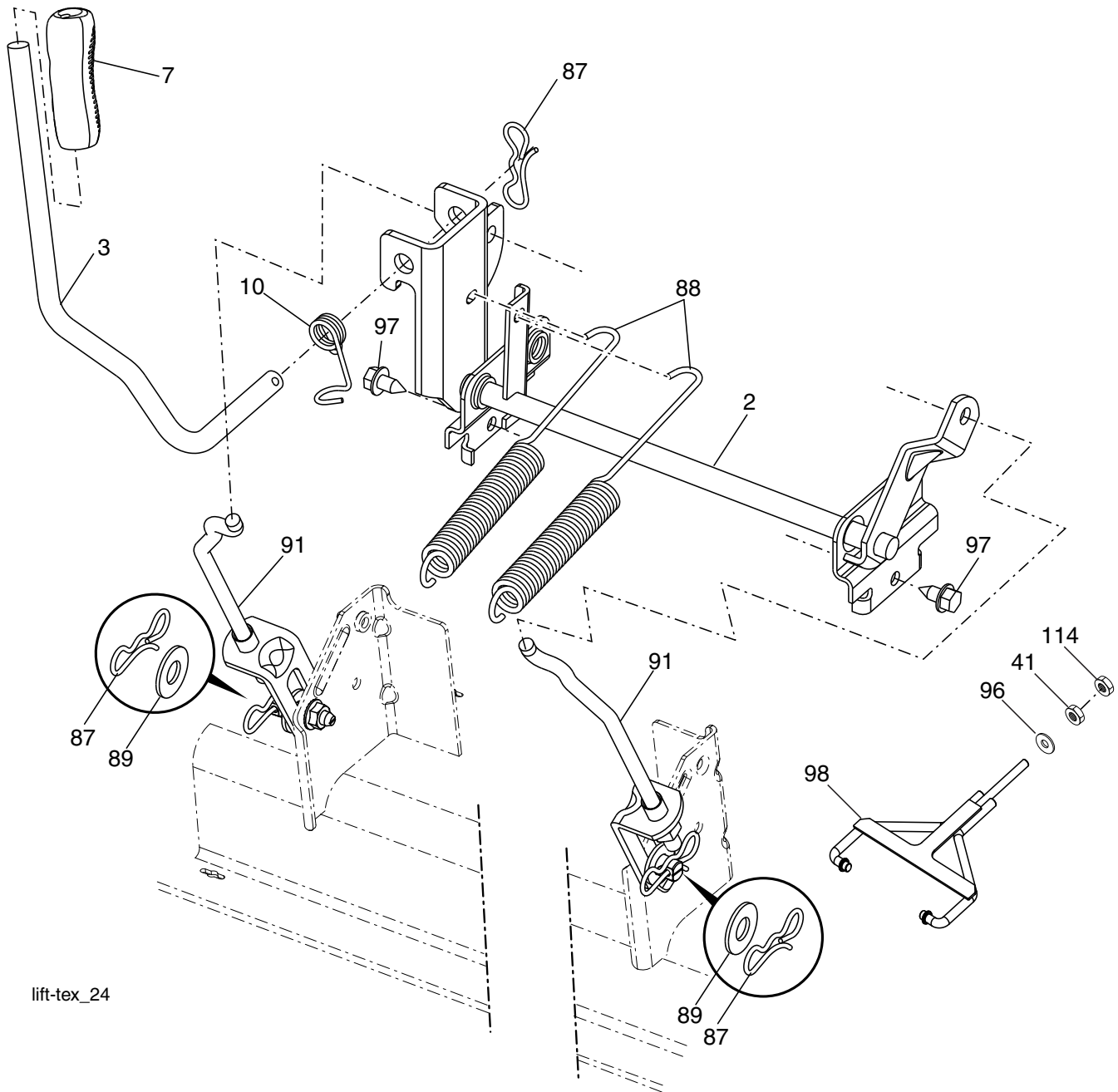

lift-tex_24

KEY PART NO.	PART NO.	DESCRIPTION
2	532 42 20-27	Shaft Asm., Lift
3	532 19 52-31	Lever Asm., Lift RH
7	580 96 23-01	Grip, Lever
10	532 19 63-14	Spring Torsion
41	532 17 59-94	Nut, Lift Link
87	532 19 42-09	Pin Cotter 7/16 Bow Tie Lock
88	532 41 07-10	Spring Lift Assist
89	819 19 19-12	Washer Clear Zinc

KEY PART NO.	PART NO.	DESCRIPTION
91	532 40 34-07	Link Lift Susp Mower Rear
96	532 19 52-63	Bushing, Spherical
97	817 00 06-12	Screw 3/8-16 x .75
98	574 82 25-01	Link Lift Susp. Front Mower
114	873 36 07-00	Nut Jam 7/16-20

NOTE: All component dimensions given in U.S. inches
1 inch = 25.4 mm

**TRACTOR - MODEL NO. YT42XLS (96043015400/01), PRODUCT NO. 960 43 01-54
SEAT ASSEMBLY**

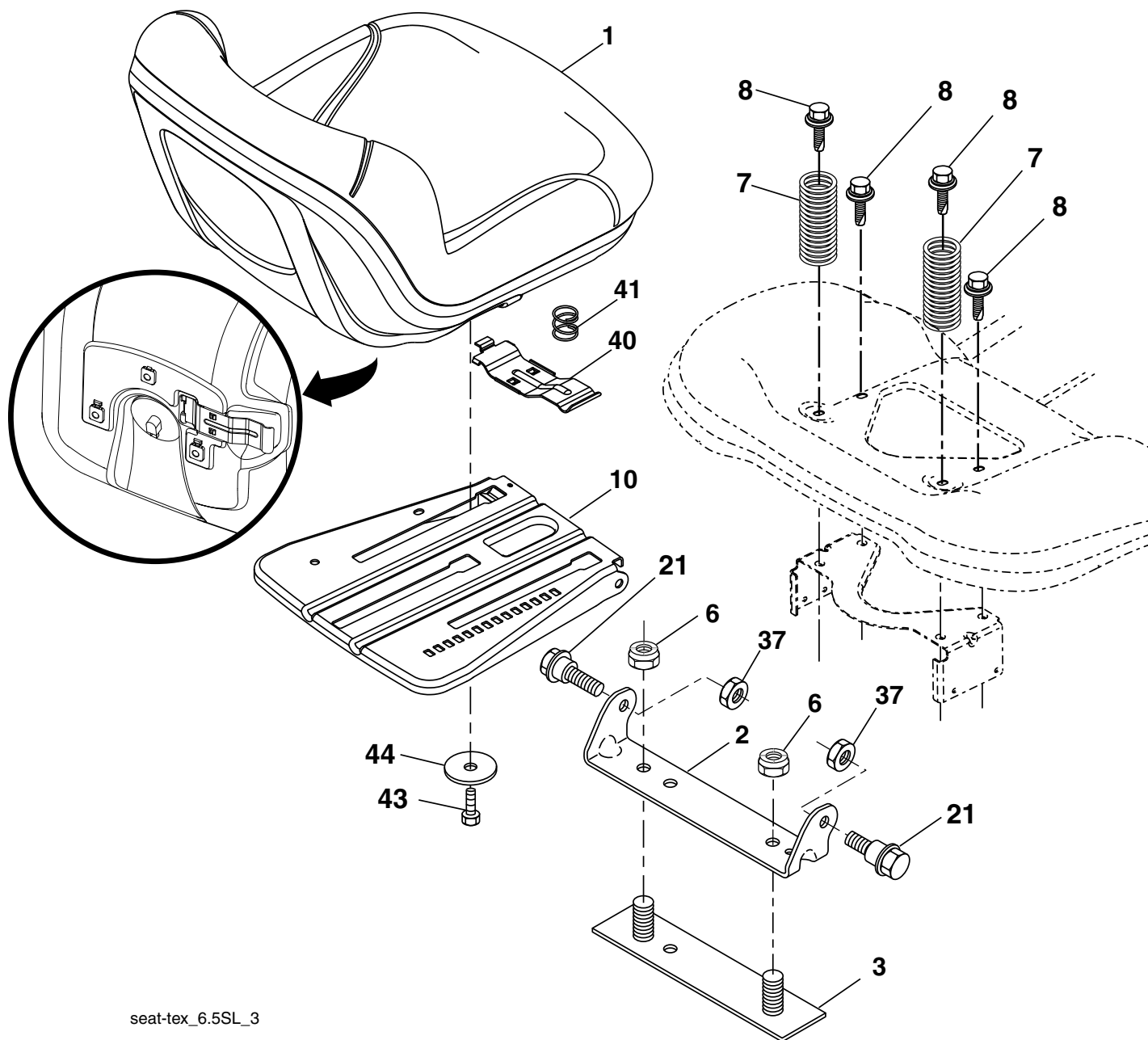

seat-tex_6.5SL_3

KEY NO.	PART NO.	DESCRIPTION
1	532 43 98-22	Seat
2	532 18 01-66	Bracket Pivot Fender
3	532 14 06-75	Strap, Asm Fender
6	873 80 06-00	Nut, Lock w/Ins. 3/8-16 unc
7	532 12 41-81	Spring, Seat Cprsn
8	532 17 18-77	Bolt 5/16-18 unc x 3/4 w/Sems
10	532 19 69-77	Pan, Seat
21	532 17 18-52	Bolt, Shoulder 5/16-18

KEY NO.	PART NO.	DESCRIPTION
37	873 80 05-00	Nut, Lock 5/16-18 unc
40	532 43 98-71	Handle Slide Seat
41	532 19 82-00	Spring Latch Seat
43	874 76 06-12	Bolt Fin Hex 3/8-16 unc x 3/4
44	819 13 38-12	Washer 13/32 x 2-3/8 x 12 Ga.

NOTE: All component dimensions given in U.S. inches
1 inch = 25.4 mm

**TRACTOR - MODEL NO. YT42XLS (96043015400/01), PRODUCT NO. 960 43 01-54
DECALS**

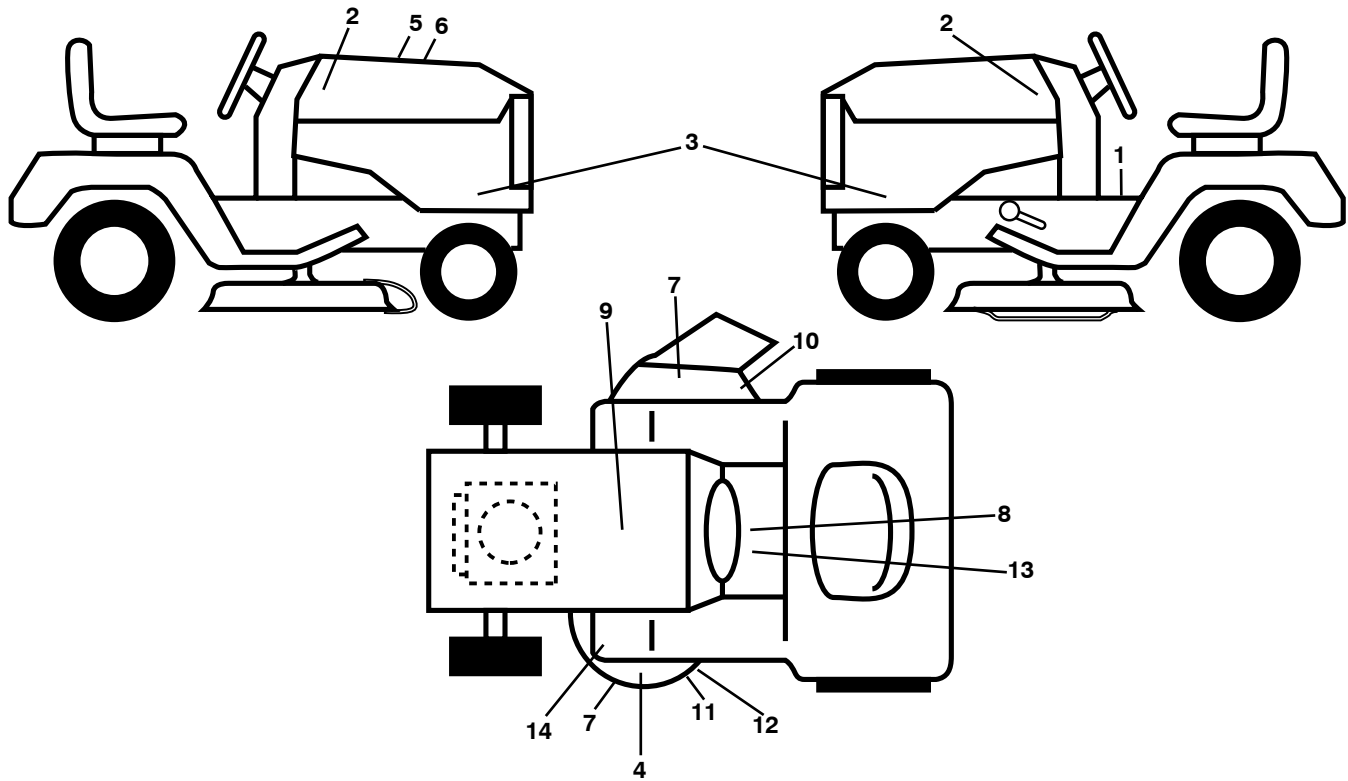

KEY NO.	PART NO.	DESCRIPTION
1	532 41 16-57	Decal, Operators
2	581 62 73-01	Badge, Hood
3	581 56 96-01	Decal, Emblem Panel SD
4	532 44 81-21	Decal, HV Reinforced Deck
5	532 42 38-29	Decal, Customer Respons.
6	581 55 82-01	Decal, Replacement
7	539 10 57-43	Decal, No Step
8	532 42 41-02	Decal, Warning Spark Arrestor
9	532 14 50-05	Decal, Battery Dnge/Poi
10	539 11 32-24	Decal, Warning
11	532 19 87-85	Decal, Deck Sch.

KEY NO.	PART NO.	DESCRIPTION
12	532 17 05-63	Decal, Warn. Keep Away
13	580 81 66-01	Lable Emissions
14	532 41 86-00	Decal, Pedal
--	532 16 69-60	Decal, Bypass
--	532 43 96-81	Pad, Footrest, LH
--	532 43 96-82	Pad, Footrest, RH
--	581 56 52-49	Manual, Operator's (English/Spanish)
--	581 56 53-49	Manual, Repair Part's (English/Spanish)

WHEELS AND TIRES

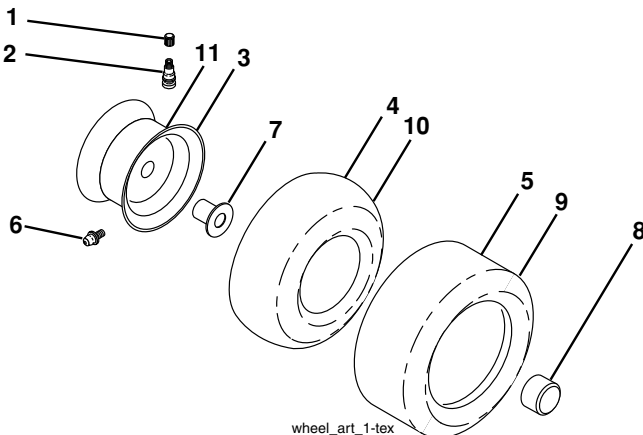

KEY NO.	PART NO.	DESCRIPTION
1	532 05 91-92	Cap Valve Tire
2	532 06 51-39	Stem Valve
3	532 18 18-39	Rim Front Service
4	532 00 81-34	Tube Front (Service Item Only)
5	532 16 10-24	Tire Front 16 x 6.5-8 Service
6	532 12 49-57	Fitting Grease (Front Wheel Only)
7	532 12 49-59	Bearing Flange (Front Wheel Only)
8	532 17 50-39	Cap Axle Blk 1 50 x 1 00
9	532 17 04-56	Tire R T 20 x 10-8 Service
10	532 12 49-26	Tube Rear (Service Item Only)
11	532 13 83-37	Rim Asm 8" Rear Service
--	532 14 43-34	Sealant, Tire (10 oz. Tube)

NOTE: All component dimensions given in U.S. inches
1 inch = 25.4 mm

TRACTOR - MODELO NO. YT42XLS (96043015400/01), PRODUCTO NO. 960 43 01-54

DIAGRAMA

SCH12-s

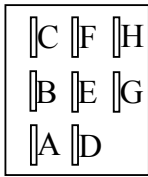
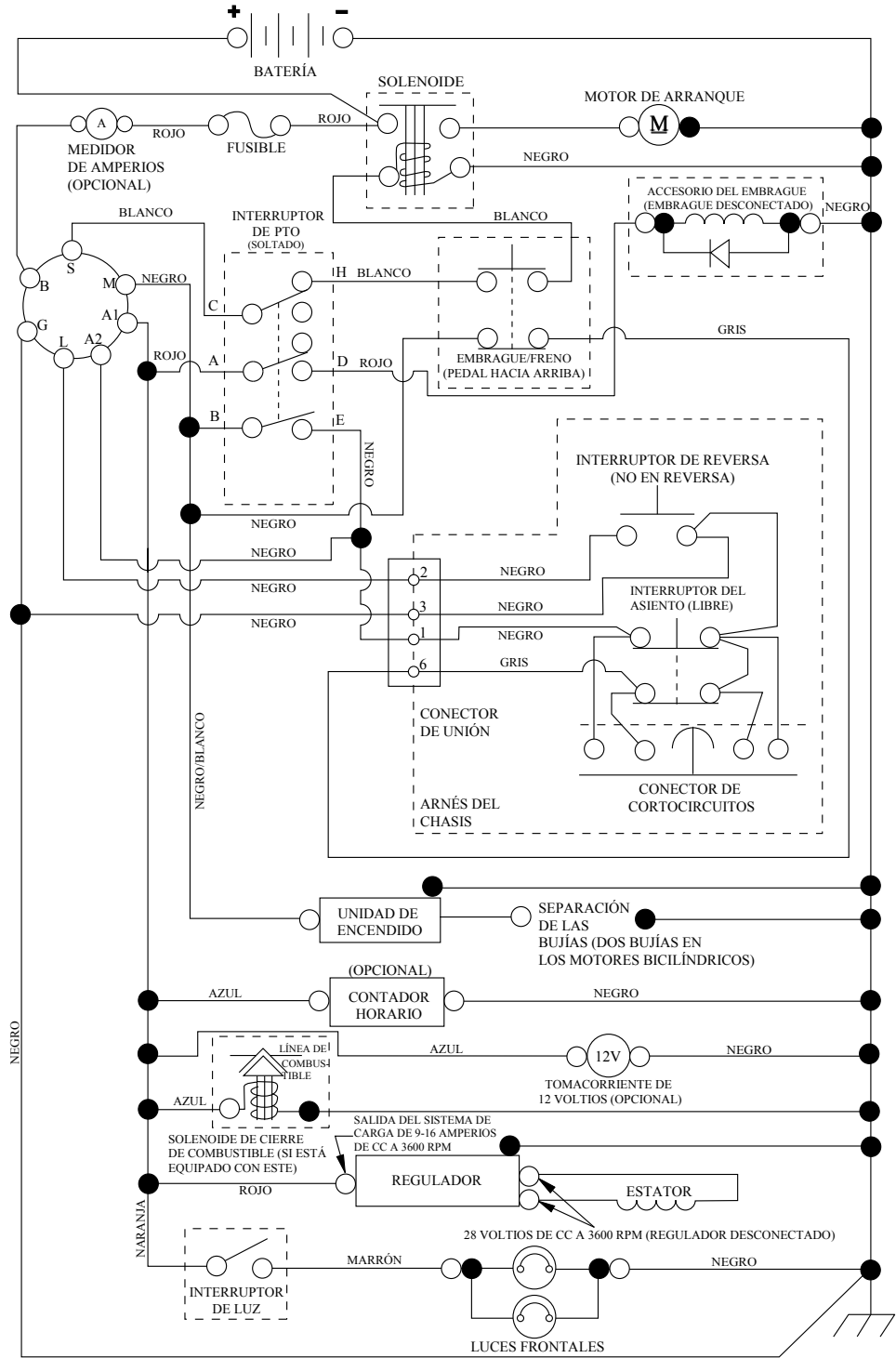

INTERRUPTOR DE PTO (CARA DE ACOPLAMIENTO)

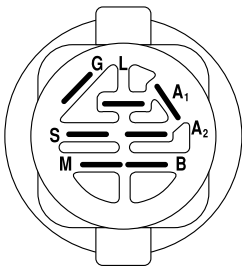

INTERRUPTOR DE ENCENDIDO

POSICIÓN	CIRCUITO «MARCA»
APAGADO	M+G+A1
PONER EN FUNCIONAMIENTO ANULAR	B+A1
PONER EN FUNCIONAMIENTO	B+A1 L+A2
ARRANCAR	B + S + A1

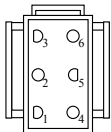

CONEXIÓN DEL ARNÉS DEL CHASIS (LATERAL QUE COINCIDA)

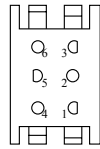

CONEXIÓN PARA EL ARNÉS DEL TABLERO

NOTA SOBRE LAS ABRAZADERAS DE AISLAMIENTO DEL CABLEADO: SI SE QUITAN LAS ABRAZADERAS DE AISLAMIENTO DEL CABLEADO PARA HACER EL MANTENIMIENTO DE LA UNIDAD, SE LAS DEBERÁ INSTALAR NUEVAMENTE PARA PROTEGER EL CABLEADO ADECUADAMENTE.

● CONEXIONES NO DESMONTABLES

○ CONEXIONES DESMONTABLES

TRACTOR - MODELO NO. YT42XLS (96043015400/01), PRODUCTO NO. 960 43 01-54
DIAGRAMA ELÉCTRICO

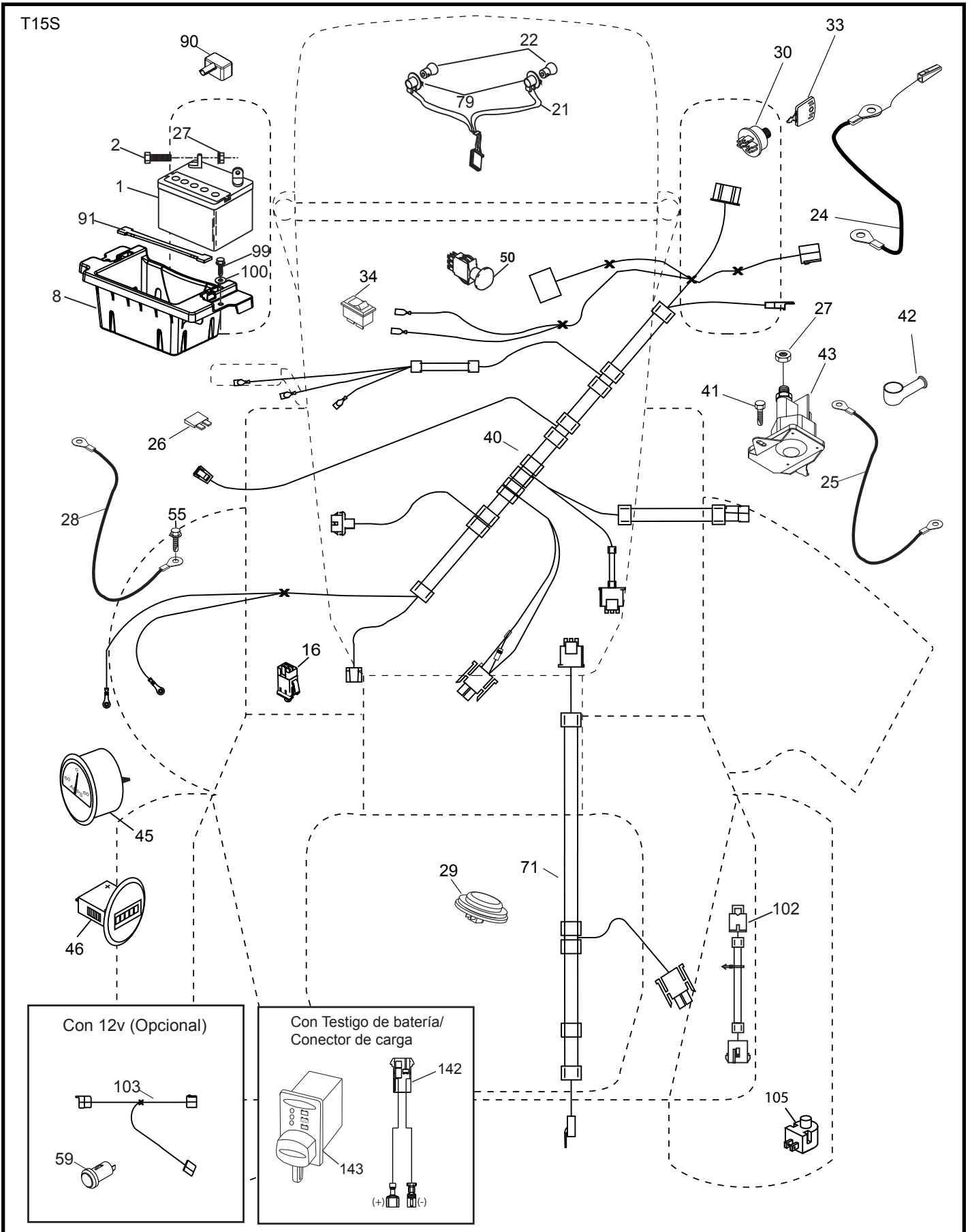

**TRACTOR - MODELO NO. YT42XLS (96043015400/01), PRODUCTO NO. 960 43 01-54
DIAGRAMA ELÉCTRICO**

CÓDIGO NO.	PIEZA NO.	DESCRIPCIÓN
1	532 16 34-65	Batería
2	874 76 04-12	Perno 1/4-20 x 3/4
8	532 41 41-26	Puerta de la caja de la batería
16	532 17 61-38	Interruptor
21	532 40 02-52	Arnés con 4152j
22	532 00 41-52	Luz
24	532 40 02-53	Cable de batería
25	532 41 28-95	Cable
26	532 17 51-58	Fusible
27	873 51 04-00	Seguridad 1/4-20 unc
28	532 14 54-91	Cable
29	532 40 15-45	Interruptor
30	532 19 33-50	Interruptor de ignición
33	532 41 19-33	Llave\cadena
34	532 11 07-12	Posición del interruptor de luz
40	581 58 35-01	Arnés
41	817 72 04-08	Tornillo 1/4-20 x 1/2
42	532 13 15-63	Cubierta
43	532 19 25-07	Solenoides
45	532 42 52-70	Amperímetro serie
46	532 42 52-71	Dispositivo de aviso de servicio
50	532 17 46-51	Interruptor pto
55	817 06 05-12	Tornillo, 5/16-18 x 3/4 tytt
59	532 40 03-03	Salida 12-v
71	532 19 42-76	Arnés de ignición/chasis
79	532 17 52-42	Enchufe de cierre por torsión del ensamble de la bombilla
90	532 43 53-95	Cubierta
91	532 19 02-70	Correa
99	817 67 04-12	Tornillo, 1/4-20 x 3/4
100	819 09 14-16	Arandela 9/32 x 7/8 x calibre 16
102	532 40 44-54	Arnés
103	532 42 17-47	Arnés 12-v
105	532 40 75-68	Interruptor
142	583 85 78-01	Cableado de conector de carga
143	532 44 80-59	Conector de carga

NOTA: Las dimensiones de todos los componentes están expresadas en pulgadas americanas. 1 pulgada = 25,4 mm

TRACTOR - MODELO NO. YT42XLS (96043015400/01), PRODUCTO NO. 960 43 01-54
CHASIS

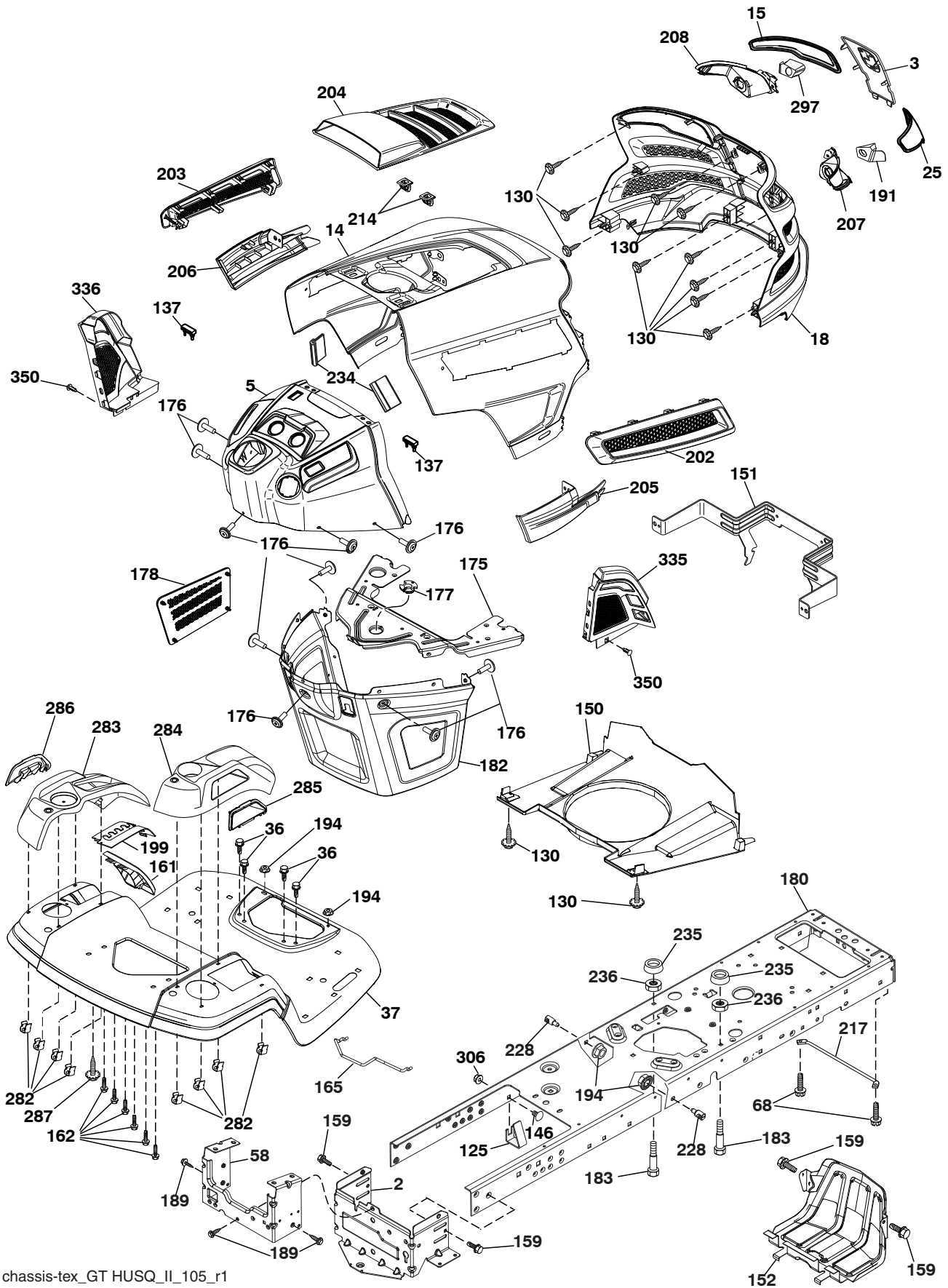

chassis-tex_GT HUSQ_II_105_r1

TRACTOR - MODELO NO. YT42XLS (96043015400/01), PRODUCTO NO. 960 43 01-54 CHASIS

CÓDIGO NO.	PIEZA NO.	DESCRIPCIÓN	CÓDIGO NO.	PIEZA NO.	DESCRIPCIÓN
2	532 41 22-82	Barra de enganche	194	873 90 05-00	Tuerca 5/16-18
3	532 44 44-81	Aplica submontaje	199	532 41 34-85	Chapa
5	532 43 74-90	Tablero	202	532 43 97-28	Salida de ventilación ld
14	532 44 11-77	Capota	203	532 43 97-27	Salida de ventilación li
15	532 43 97-33	Lente izquierdo de la parrilla	204	532 43 57-14	Salida de ventilación superior
18	532 44 06-53	Parrilla	205	532 43 97-30	Skirt hood side ld
25	532 44 33-85	Lente derecho de la parrilla	206	532 43 97-29	Skirt hood side li
36	817 06 05-12	Tornillo 5/16-18 x 3/4	207	532 43 97-34	Bezel ld
37	532 44 11-78	Guardabarros	208	532 43 97-35	Bezel li
58	532 41 22-80	Barra de enganche	214	532 19 91-45	Cierre
68	817 49 05-08	Tornillo 5/16-18 x 1/2	217	532 40 91-67	Varilla giratoria
125	581 68 48-01	Soporte	228	532 19 51-61	Sujetador del travesaño
130	532 41 63-58	Tornillo #10 x 0.750	234	532 40 47-42	Cubierta Capota
137	532 40 75-90	Cubierta tablero	235	532 40 61-29	Separador del guardabarros
146	581 85 79-01	Perno	236	873 93 05-00	Tuerca 5/16-18 unc
150	532 43 97-74	Cubierta térmica del conducto	282	532 41 41-10	Cierre
151	532 43 66-70	Soporte	283	532 43 98-23	Ensamble de la consola de la
152	532 43 98-70	Protector contra oscurecimiento			Plataforma de elevación
159	817 00 06-12	Tornillo 3/8-16 x 3/4	284	532 43 98-61	Ensamble de la consola
161	532 43 97-81	Ventana	285	532 41 63-15	Parrilla consola ld
162	532 14 24-32	Tornillo	286	532 41 63-17	Parrilla consola li
165	532 19 43-30	Soporte	287	817 60 04-06	Tornillo 1/4-20 x 3/8
175	532 19 63-04	Travesaño	297	532 43 74-56	Parrilla reflector li
176	532 40 07-76	Tornillo 10-24 x 5/8	306	873 90 06-00	Tuerca
177	532 19 52-27	Buje de dirección	335	532 44 82-04	Cubierta ld
178	532 19 97-82	Carga la asamblea neta	336	532 44 53-09	Cubierta li
180	532 44 55-59	Chasis	350	532 44 51-43	Clip del árbol de navidad
182	532 40 68-59	Tablero inferior	--	532 44 80-86	Kit del protector del cepillo
183	874 52 05-20	Perno 5/16-18 x 1-1/4			
189	817 00 05-12	Tornillo 5/16-18 x 3/4			
191	532 43 74-55	Parrilla reflector ld			

NOTA: Las dimensiones de todos los componentes están expresadas en pulgadas americanas. 1 pulgada = 25,4 mm

TRACTOR - MODELO NO. YT42XLS (96043015400/01), PRODUCTO NO. 960 43 01-54
TRANSMISIÓN

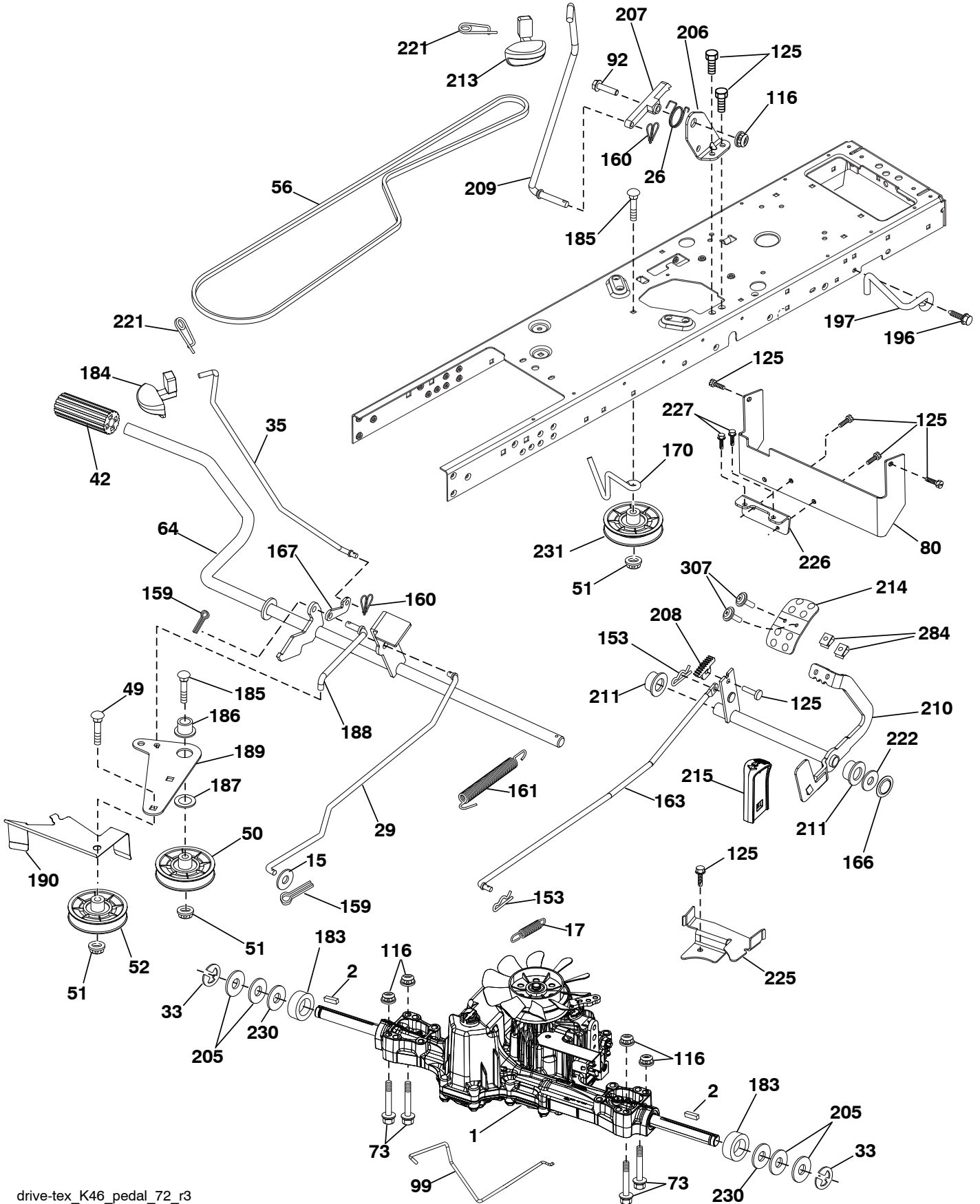

drive-tex_K46_pedal_72_r3

TRACTOR - MODELO NO. YT42XLS (96043015400/01), PRODUCTO NO. 9604301-54 TRANSMISIÓN

CÓDIGO NO.	PIEZA NO.	DESCRIPCIÓN	CÓDIGO NO.	PIEZA NO.	DESCRIPCIÓN
1	---	Transeje, TUFFTORQ K46CR (426121) (Haga el pedido de las piezas al fabricante del transeje)	188	532 19 43-23	Mecanismo de desplazamiento de la varilla de mando del embrague
2	532 12 35-83	Cuña	189	532 19 43-17	Palanca acodada del mecanismo de desplazamiento
15	819 13 13-16	Arandela 13/32 x 13/16 x calibre 16	190	532 19 43-18	Sujetador de la palanca acodada del mecanismo de desplazamiento
17	532 41 36-78	Resorte de freno	196	817 00 06-16	Tornillo 3/8-16 x 1
26	532 19 96-79	Crucero con retorno de muelle	197	532 19 58-04	Soporte
29	532 40 38-06	Varilla del freno	205	532 12 17-48	Arandela
33	812 00 00-01	Aro e	206	532 19 78-67	Soporte
35	583 86 45-01	Varilla del freno de mano	207	532 19 78-68	Bloqueo del control del crucero
42	532 12 48-72	Cubierta del pedal	208	532 19 78-69	Engranaje del sector de control del crucero
49	872 11 06-14	Perno	209	532 19 95-92	Varilla de control del crucero
50	532 19 43-27	Polea loca plana	210	532 40 09-80	Ensamble del balancín del control del pedal
51	873 90 06-00	Tuerca 3/8-16	211	532 12 01-83	Rodamiento de nylon
52	532 19 43-26	Polea loca con ranura en v con un desplazamiento de 910" (23 m)	213	532 40 31-19	Perilla de control del crucero
56	532 13 09-69	Correa trapezoidal de la transmisión	214	532 41 68-63	Forro del pedal para avanzar
64	532 19 78-65	Ensamble del eje control del pedal de freno	215	532 40 17-23	Forro del pedal para retroceder
73	874 49 05-40	Perno 5/16-18 x 2.1/2 G5	221	532 40 31-87	Abrazadera de retención del resorte de la manija
80	532 44 06-19	Soporte de la correa de torsión	222	879 21 20-10	Arandela 21/32 x 1-1/4 x calibre 10
92	874 76 05-20	Perno 5/16-18 unc x 1.25	225	532 40 33-19	Ensamble del sujetador de la correa del motor
99	532 41 57-42	Varilla	226	532 40 15-64	Soporte
116	873 90 05-00	Tuerca 5/16-18	227	817 49 05-12	Tornillo 5/16-18 x 3/4
125	817 00 05-12	Tornillo 5/16-18 x 3/4	230	532 18 89-67	Arandela
153	532 12 47-88	Resorte	231	532 40 72-87	Idler Groove
159	876 02 04-12	Pasador de chaveta de 1/8 x 3/4	284	532 41 76-93	Tuerca 1/4-20 550dp .350 Pnl
160	532 16 94-84	Pinzas de retención	307	874 18 04-12	Tornillo 1/4-20 x 3/4
161	532 10 57-09	Resorte			
163	532 44 82-75	Varilla			
166	532 42 91-64	Tuerca			
167	532 40 52-57	Pestillo del freno de mano			
170	532 41 34-30	Sujetador de la correa central			
183	532 13 70-57	Espaciador			
184	532 44 14-55	Manija del freno de mano			
185	872 11 06-22	Perno 3/8-16 x 2-3/4 gr. 5			
186	532 19 43-21	Espaciador de retención			
187	819 13 32-10	Arandela			

NOTA: Las dimensiones de todos los componentes están expresadas en pulgadas americanas. 1 pulgada = 25,4 mm

**TRACTOR - MODELO NO. YT42XLS (96043015400/01), PRODUCTO NO. 960 43 01-54
MOTOR**

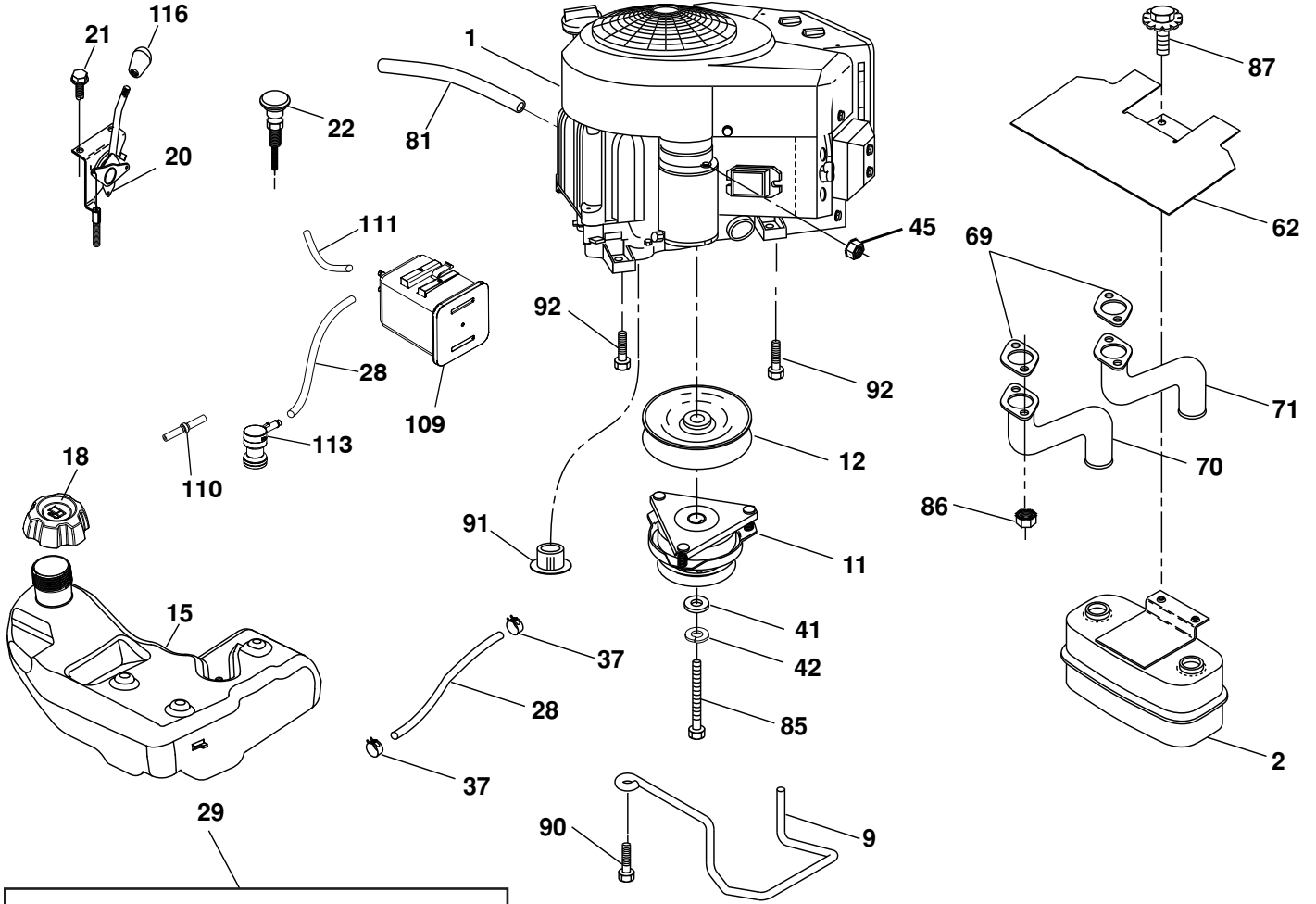

EQUIPO APAGACHISPAS

engine-tex_Kawa-2cyl_5_r1

**TRACTOR - MODELO NO. YT42XLS (96043015400/01), PRODUCTO NO. 960 43 01-54
MOTOR**

CÓDIGO NO.	PIEZA NO.	DESCRIPCIÓN
1	-----	Motor Kawa modelo No. FR691-ES15 (581557501) (Haga el pedido de las piezas al fabricante del motor)
2	532 44 59-62	Silenciador
9	532 19 43-20	Ensamble del sujetador de la correa del motor
11	532 40 00-08	Embrague
12	532 40 50-97	Polea del motor
15	532 41 41-51	Tanque de combustible
18	532 43 92-08	Ensamble de la tapa
20	532 42 43-41	Control del regulador/obturador
21	532 41 63-58	Tornillo #10 x .750
22	532 19 15-96	Control de la estrangulación del motor
28	532 40 11-35	Línea de combustible
29	532 13 71-80	Equipo apagachispas
37	532 12 34-87	Abrazadera de la manguera
41	532 12 61-97	Arandela 1-1/2 OD x 15/32 ID x .250
42	810 04 07-00	Arandela 7/16
45	873 51 04-00	Tuerca 1/4-20 unc
62	532 43 40-17	Silenciador con pantalla térmica
69	532 17 81-51	Junta
70	583 95 56-01	Tubo de escape izquierdo (LI)
71	583 95 57-01	Tubo de escape derecho (LD)
81	532 14 84-56	Tubo de fácil drenaje de aceite
85	532 17 39-37	Perno 7/16-20 x 4 x Gr. 5-1.5 Thr
86	532 18 43-62	Tuerca
87	537 17 18-77	Perno 5/16-18 unc x 3/4 w/Sems
90	817 00 06-16	Tornillo 3/8-16 x 1
91	532 18 74-95	Buje
92	817 12 06-16	Tornillo 3/8-16 x 1
109	532 41 41-14	Filtro de carbono
110	532 41 41-18	Montaje de válvula
111	532 41 41-19	Línea de la purgación
113	532 41 41-27	Válvula inclinada
116	539 13 26-24	Perilla

NOTA: Las dimensiones de todos los componentes están expresadas en pulgadas americanas. 1 pulgada = 25,4 mm

Para las piezas del servicio y de recambio del motor, llame el número gratis para su fabricante del motor enumerado abajo:

Kawasaki 1-949-460-5688

TRACTOR - MODELO NO. YT42XLS (96043015400/01), PRODUCTO NO. 960 43 01-54
ENSAMBLE DE LA DIRECCIÓN

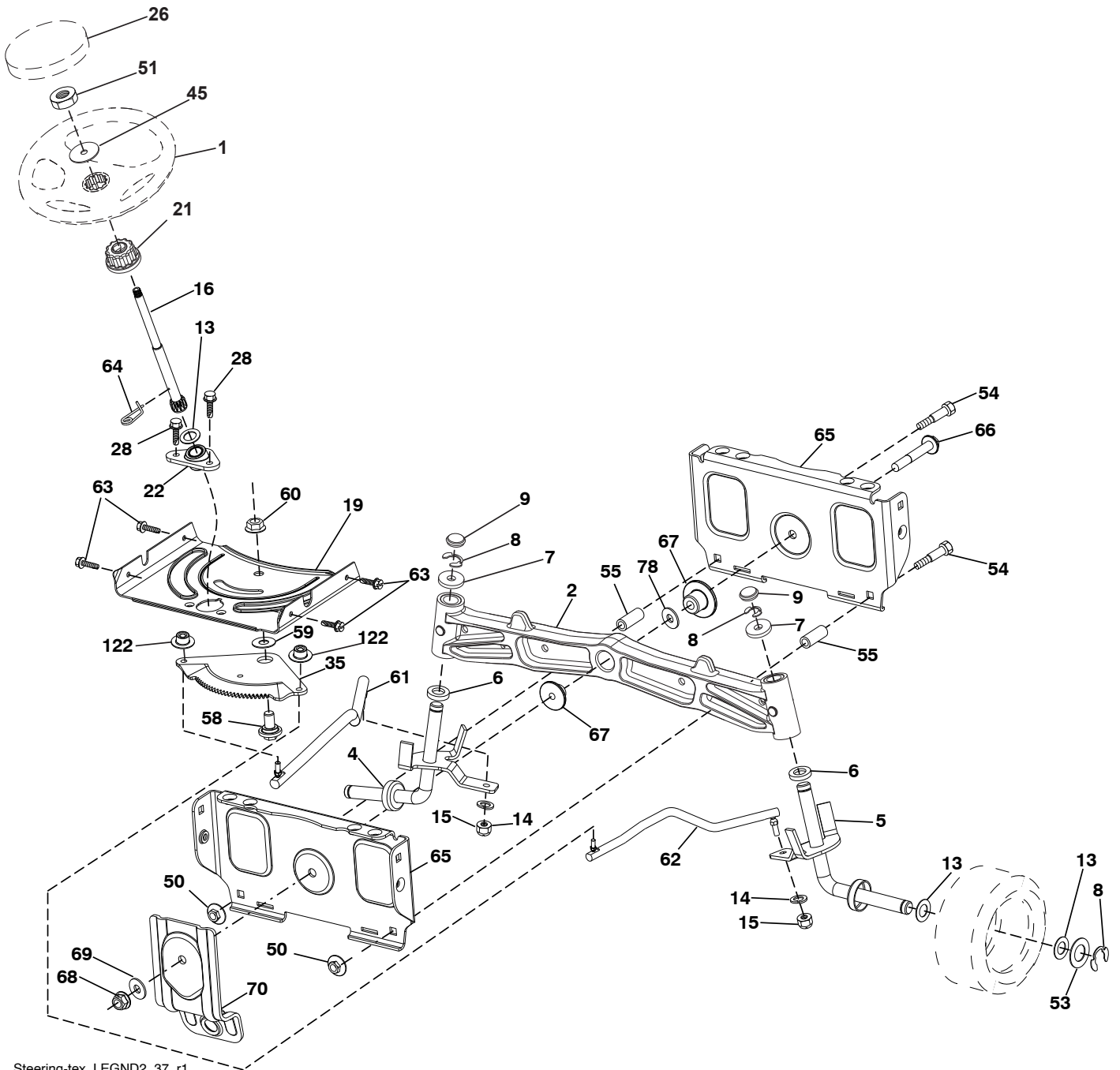

Steering-tex_LEGND2_37_r1

**TRACTOR - MODELO NO. YT42XLS (96043015400/01), PRODUCTO NO. 960 43 01-54
ENSAMBLE DE LA DIRECCIÓN**

CÓDIGO NO.	PIEZA NO.	DESCRIPCIÓN
1	532 43 97-40	Volante de dirección
2	532 19 59-68	Ensamble del eje delantero
4	532 40 30-89	Ensamble del husillo izquierdo
5	532 40 30-90	Ensamble del husillo derecho
6	532 12 49-31	Beju
7	532 12 17-48	Arandela 25/32 x 1-5/8 x calibre 16
8	812 00 00-29	Abrazadera del aro No. T5304-75
9	532 12 12-32	Tapa del husillo
13	532 12 17-49	Arandela 25/32 x 1-1/4 x calibre 16
14	810 04 06-00	Arandela 3/8
15	873 54 06-00	Tuerca 3/8-24 unf
16	532 40 82-19	Eje de dirección
19	532 19 47-29	Placa de dirección
21	532 18 67-37	Adaptador del volante de dirección
22	532 42 05-37	Soporte
26	532 43 97-43	Inserto del volante de dirección
28	817 00 06-12	Tornillo 3/8-16 x 3/4
35	532 19 47-32	Engranaje del sector de la placa
45	819 18 38-12	Arandela 9/16 ID x 2-3/8 OD calibre 12
50	873 90 06-00	Tuerca 3/8-16 unc
51	873 94 08-00	Tuerca 1/2-20 unf
53	532 18 89-67	Arandela .793 x 1.637 x .060
54	874 76 06-36	Perno 3/8-16 x 2-1/4
55	532 41 47-36	Soporte
58	532 19 47-47	Perno
59	532 19 47-48	Arandela
60	873 97 10-00	Tuerca 5/8-11
61	532 19 47-40	Barra de acoplamiento izquierda
62	532 19 47-41	Barra de acoplamiento derecha
63	817 00 05-12	Tornillo 5/16-18 x 3/4
64	532 19 98-49	Abrazadera de retención del resorte de la dirección
65	532 19 47-34	Soporte
66	871 02 07-48	Perno 7/16-14 x 3 Serr
67	532 19 47-37	Beju
68	873 90 07-00	Tuerca 7/16-14 Gr. 5
69	532 19 91-62	Arandela 1.5 x .505 x .118
70	532 19 61-97	Soporte de la plataforma delantera
78	532 05 70-79	Arandela
122	532 44 49-62	Tapa

NOTA: Las dimensiones de todos los componentes están expresadas en pulgadas americanas. 1 pulgada = 25,4 mm

**TRACTOR - MODELONO. YT42XLS (96043015400/01), PRODUCTO NO. 960 43 01-54
PLATAFORMA DE LA CORTADORA DE CÉSPED**

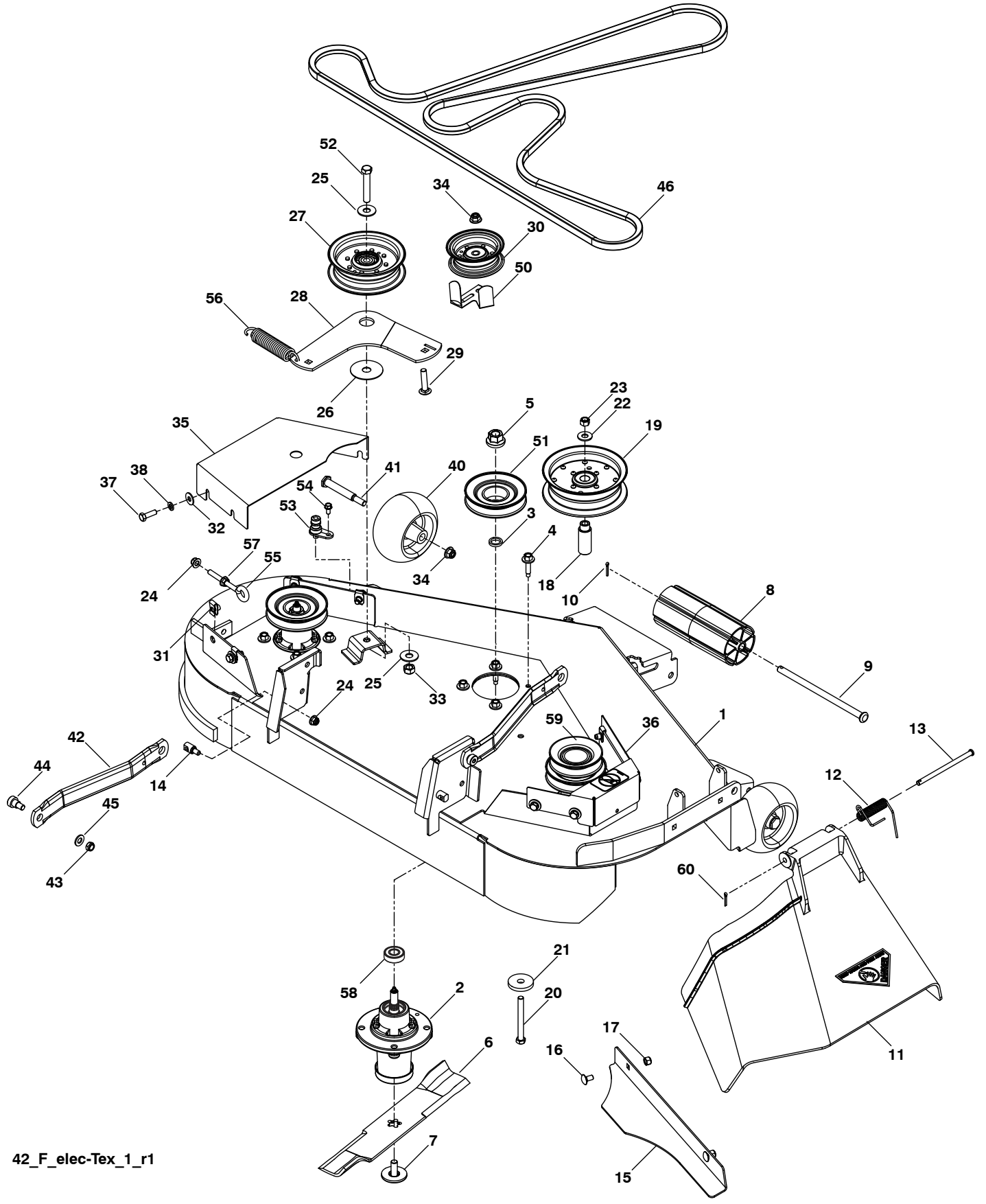

42_F_elec-TEX_1_r1

**TRACTOR - MODELO NO. YT42XLS (96043015400/01), PRODUCTO NO. 9604301-54
PLATAFORMA DE LA CORTADORA DE CÉSPED**

CÓDIGO NO.	PIEZA NO.	DESCRIPCIÓN	CÓDIGO NO.	PIEZA NO.	DESCRIPCIÓN
1	574 77 89-02	Carcasa de la cortadora de césped	32	539 99 06-92	Arandela 5/16
2	539 11 21-70	Carcasa de la cortadora de césped	33	539 11 91-24	Tuerca 7/16-14
3	539 18 76-90	Arandela	34	521 99 65-01	Tuerca 3/8-16
4	532 17 39-84	Tornillo	35	575 22 47-02	Cubierta izquierda del mandril
5	539 40 02-34	Tuerca 9/16	36	575 96 71-02	Cubierta derecha del mandril
6	539 11 20-78	Cuchilla de la cortadora de césped 14-5/8"	37	539 99 02-09	Perno 5/16-18 x 1 Ga. 5
7	532 19 30-03	Perno 7/16	38	539 99 01-87	Arandela 5/16
8	532 17 60-66	Mida la rueda	40	532 13 39-57	Mida la rueda
9	532 17 91-27	Varilla de la bisagra	41	539 19 34-06	Perno
10	532 19 42-08	Retorno del resorte	42	532 19 51-85	Brazo de la suspensión
11	539 11 07-31	Protector del deflector - 42"	43	539 20 02-82	Tuerca 3/8-16
12	539 11 07-35	Resorte de torsión	44	539 11 36-21	Perno 3/8-16 x 3/8
13	539 11 07-36	Perno 5/16 x 5.19	45	539 99 01-22	Arandela 3/8
14	532 19 51-61	Perno	46	574 84 56-01	Correa trapezoidal
15	539 11 24-12	Placa	50	575 22 43-01	Protector
16	539 99 07-99	Perno 5/16-18 x 5/8 Gr. 5	51	575 22 44-01	Polea del mandril
17	539 99 07-17	Tuerca 5/16-18	52	539 10 48-70	Perno 7/16-14 x 2-1/2 Ga. 5
18	575 22 45-01	Beju	53	532 41 55-98	Puerto De Lavado De La Cubierta
19	539 13 27-28	Polea loca	54	539 10 84-61	Perno 1/4-20 x 1/2
20	539 10 82-71	Perno 3/8-16 x 3-1/2 Ga. 5	55	539 11 55-74	Perno 5/16 x 3-1/2
21	539 10 65-04	Arandela	56	539 10 68-50	Retorno del resorte
22	539 99 05-17	Arandela 3/8	57	539 13 20-19	Tuerca 5/16-18 Hex
23	539 97 69-79	Tuerca 3/8-16	58	532 11 04-85	Beju
24	539 11 28-99	Tuerca 5/16-18	59	575 41 62-01	Polea
25	539 10 48-64	Arandela 7/16	60	532 16 94-84	Retorno del resorte
26	532 17 85-15	Arandela	--	532 41 64-05	Accesorio del conexión
27	532 19 61-04	Polea loca	--	532 44 53-57	Reemplazo de la cortadora de césped, completa
28	574 82 71-01	Brazo de la suspensión			
29	539 99 09-23	Perno 3/8-16 x 1-3/4 Ga. 5			
30	532 17 79-68	Polea loca			
31	539 10 47-63	Retainer 5/16c U Type			

NOTA: Las dimensiones de todos los componentes están expresadas en pulgadas americanas. 1 pulgada = 25,4 mm

**TRACTOR - MODELO NO. YT42XLS (96043015400/01), PRODUCTO NO. 960 43 01-54
ELEVACIÓN DE LA CORTADORA DE CÉSPED**

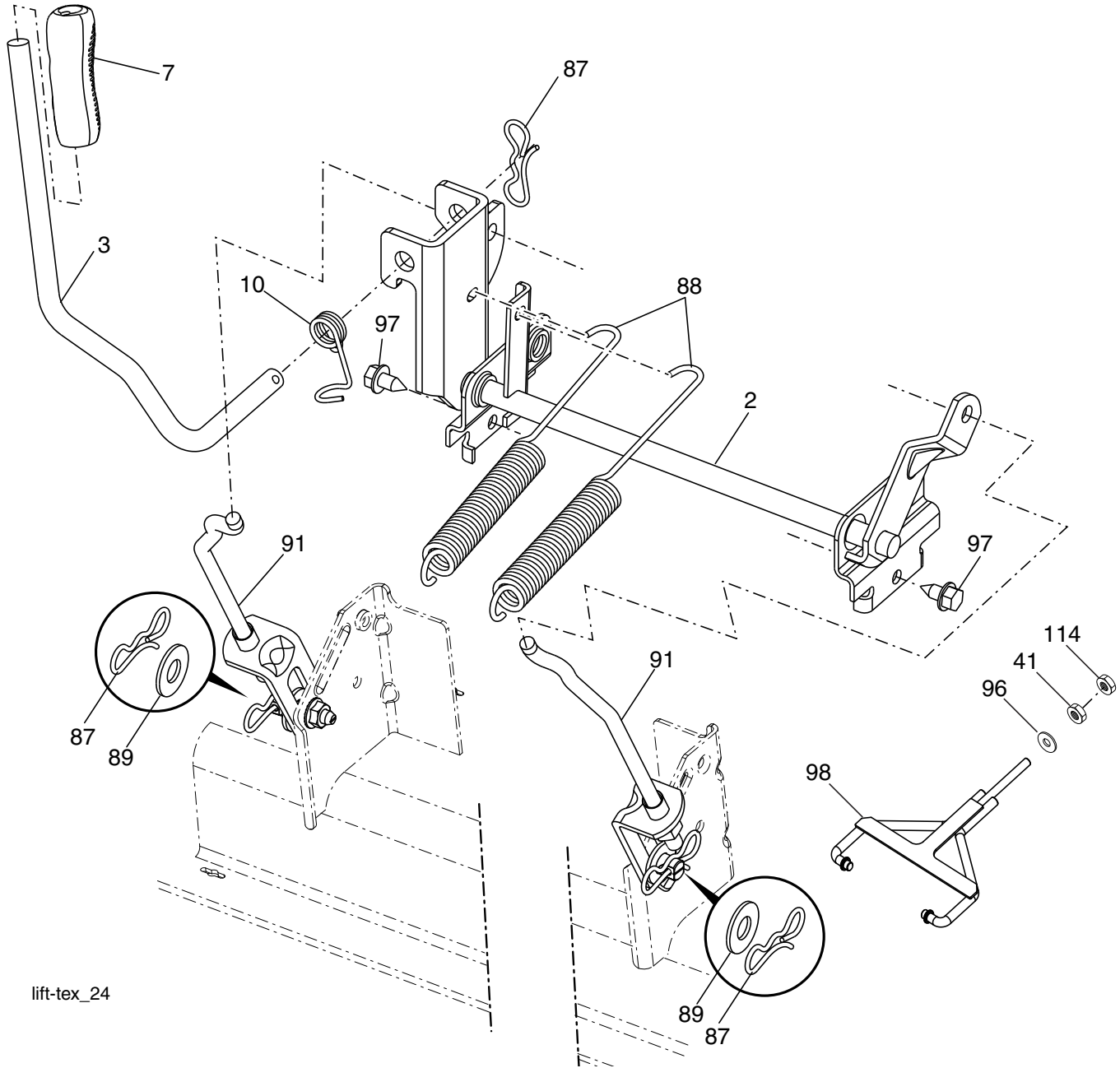

lift-tex_24

CÓDIGO NO.	PIEZA NO.	DESCRIPCIÓN
2	532 42 20-27	Ensamble del eje de la elevación
3	532 19 52-31	Ensamble de la palanca de elevación derecha
7	580 96 23-01	Mango de la palanca
10	532 19 63-14	Resorte de torsión
41	532 17 59-94	Tuerca
87	532 19 42-09	Pasador de chaveta de 7/16 con bloqueo en forma de mariposa
88	532 41 07-10	Resorte de ayuda de la elevación
89	819 19 19-12	Arandela de zinc transparente

CÓDIGO NO.	PIEZA NO.	DESCRIPCIÓN
91	532 40 34-07	Ensamble del acoplamiento
96	532 19 52-63	Elevación trasera
97	817 00 06-12	Beju
98	574 82 25-01	Tornillo de 3/8-16 x 0,75
114	873 36 07-00	Acoplamiento frontal de la elevación de la cortadora de césped
		Tuerca 7/16-20

NOTA: Las dimensiones de todos los componentes están expresadas en pulgadas americanas. 1 pulgada = 25,4 mm

**TRACTOR - MODELO NO. YT42XLS (96043015400/01), PRODUCTO NO. 960 43 01-54
ENSAMBLE DEL ASIENTO**

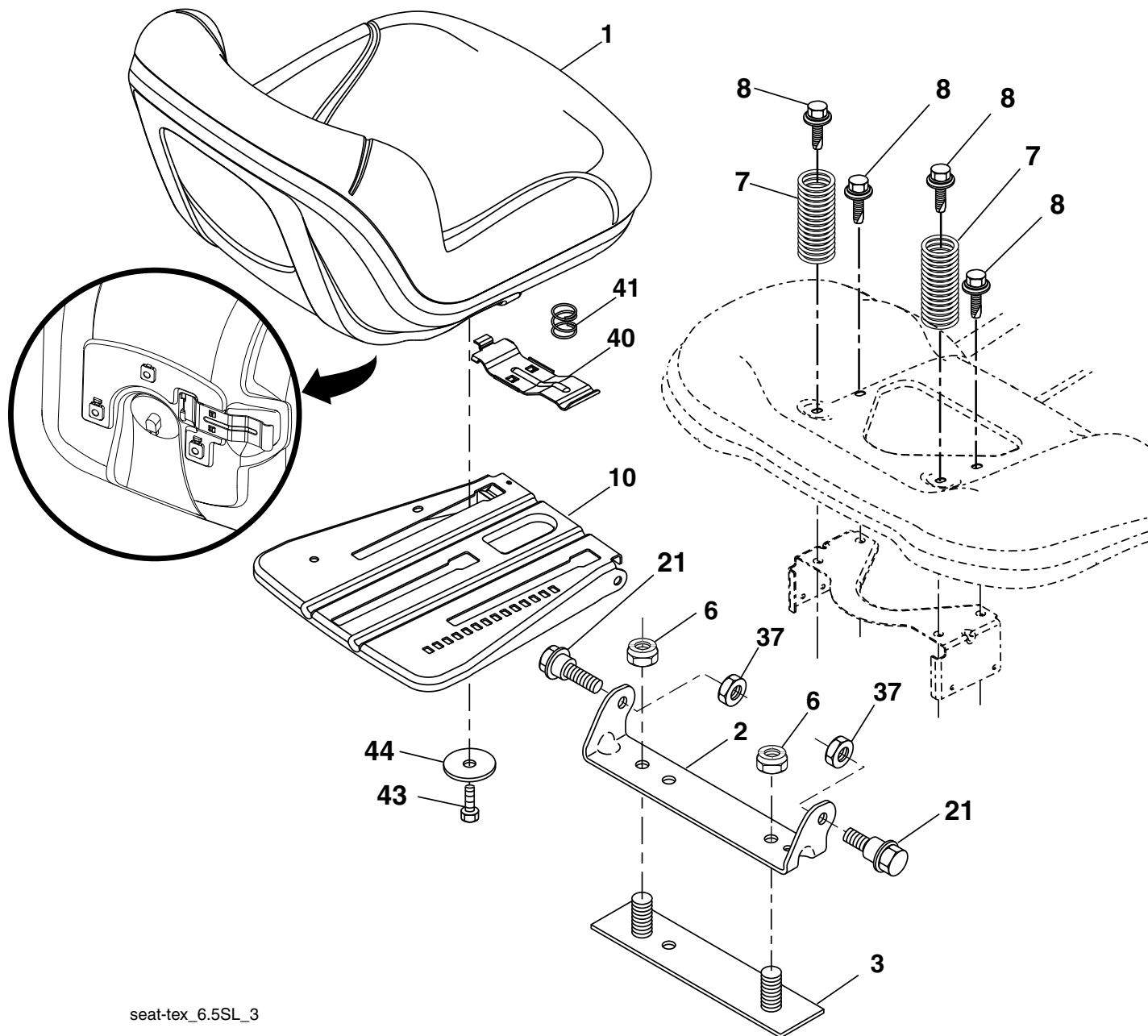

seat-tex_6.5SL_3

CÓDIGO NO.	PIEZA NO.	DESCRIPCIÓN
1	532 43 98-22	Asiento
2	532 18 01-66	Soporte pivotante del guardabarros
3	532 14 06-75	Conector del ensamble del guardabarros
6	873 80 06-00	Tuerca 3/8-16 unc
7	532 12 41-81	Resorte del asiento
8	532 17 18-77	Perno de 5/16" UNC x 3/4"
10	532 19 69-77	Bandeja del asiento
21	532 17 18-52	Perno de tope de 5/16-18
37	873 80 05-00	Tuerca 5/16-18 unc

CÓDIGO NO.	PIEZA NO.	DESCRIPCIÓN
40	532 43 98-71	Manija para deslizar el asiento
41	532 19 82-00	Resorte para trabar el asiento
43	874 76 06-12	Perno de cabeza hexagonal con aleta de 3/8-16 UNC x 3/4
44	819 13 38-12	Arandela 13/32 x 2-3/8 x calibre 12

NOTA: Las dimensiones de todos los componentes están expresadas en pulgadas americanas. 1 pulgada = 25,4 mm

**TRACTOR - MODELO NO. YT42XLS (96043015400/01), PRODUCTO NO. 960 43 01-54
CALCOMANÍAS**

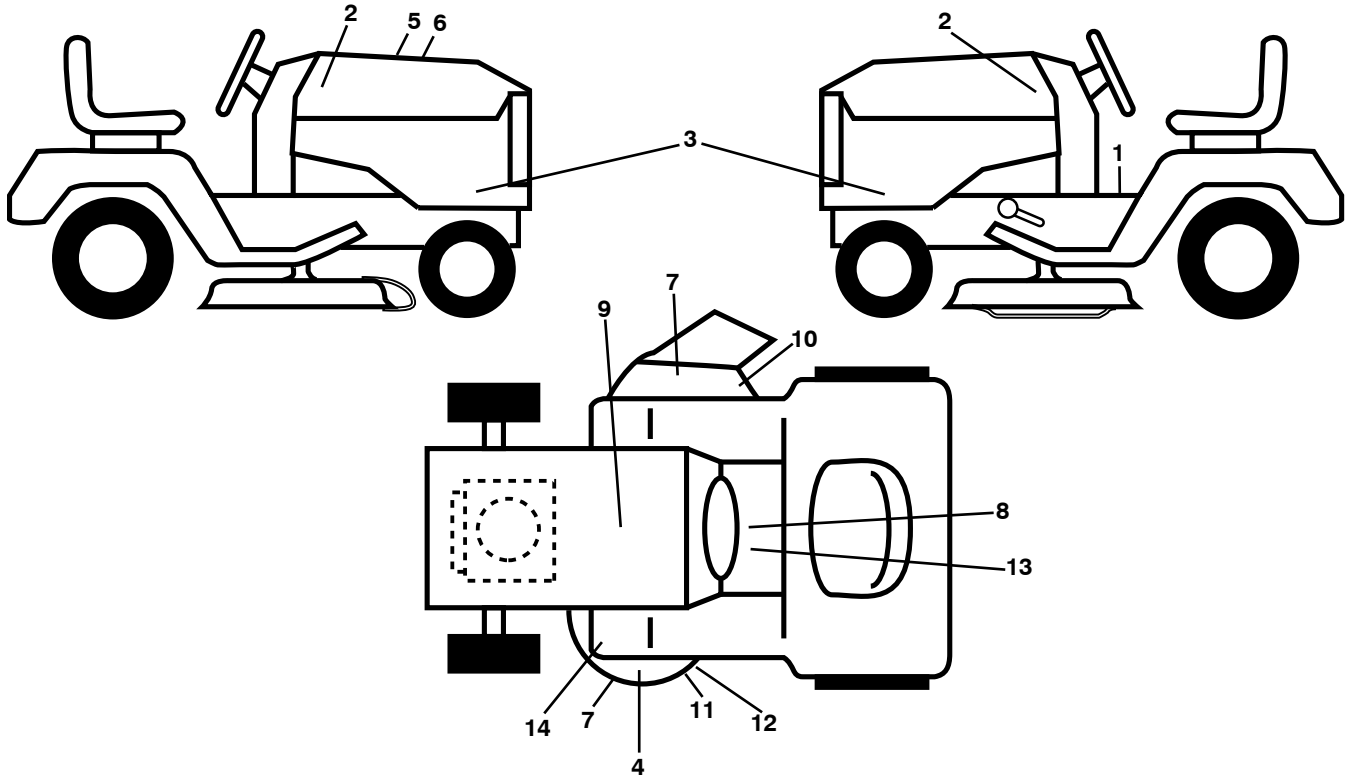

CÓDIGO NO.	PIEZA NO.	DESCRIPCIÓN
1	532 41 16-57	Calcomanía para el guardabarros del operador
2	581 62 73-01	Calcomanía para el insignia
3	581 56 96-01	Calcomanía para el panel lateral
4	532 44 81-21	Calcomanía reforzado de cubierta
5	532 42 38-29	Calcomanía del cliente
6	581 55 82-01	Calcomanía de reemplazo
7	539 10 57-43	Calcomanía ningún n paso
8	532 42 41-02	Calcomanía de Equipo apagachispas
9	532 14 50-05	Calcomanía de Peligro/Punto de interconexión

CÓDIGO NO.	PIEZA NO.	DESCRIPCIÓN
10	539 11 32-24	Calcomanía de Equipo
11	532 19 87-85	Calcomanía diagrama de la cubierta
12	532 17 05-63	Calcomanía de advertencia
13	580 81 66-01	Emissiones lable
14	532 41 86-00	Calcomanía del pedal
--	532 16 69-60	Calcomanía para la desviación
--	532 43 96-81	Forro del apoyo para los pies (LD)
--	532 43 96-82	Forro del apoyo para los pies (LI)
--	581 56 52-49	Manual de Operario (Inglês/Espanhol)
--	581 56 53-49	Manual de Repuestos (Inglês/Espanhol)

RUEDAS Y NEUMÁTICOS

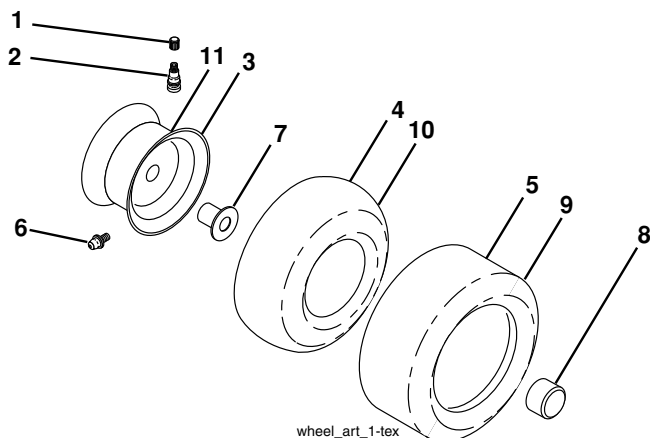

CÓDIGO NO.	PIEZA NO.	DESCRIPCIÓN
1	532 05 91-92	Tapa de la válvula del neumático
2	532 06 51-39	Vástago de la válvula
3	532 18 18-39	Ensamble de las llantas delanteras
4	532 00 81-34	Cámara delantera
5	532 16 10-24	Neumático delantero 16 x 6.5-8
6	532 12 49-57	Accesorio para engrasar (solo para la rueda delantera)
7	532 12 49-59	Rodamiento de la brida (solo para la rueda delantera)
8	532 17 50-39	Tapa del eje 1 50 x 1 00
9	532 17 04-56	Neumático trasero 20 x 10-8
10	532 12 49-26	Cámara trasera (Mantenimiento sólo)
11	532 13 83-37	Ensamble trasero de la llanta
--	532 14 43-34	Sellador para neumáticos (tubo de 10 onzas [283 gr])

NOTA: Las dimensiones de todos los componentes están expresadas en pulgadas americanas. 1 pulgada = 25,4 mm

NOTES/AVISO

09/04/2013 BD