

# Repair Parts Manual Manual De Repuestos

YT46LS / 96043016701

Please read the operator's manual carefully and make sure you understand the instructions before using the machine.

Por favor lea cuidadosamente y comprenda estas intrucciones antes de usar esta maquina.



**English/Spanish**

**586 00 01-27 Rev. 1**



# HOW TO USE THIS MANUAL

This manual is designed to provide the customer with a means to identify the parts on his/her tractor when ordering repair parts. The illustrations may or may not represent the actual assemblies; therefore, it is not recommended to use this manual as a guide to assemble or disassemble the tractor. Some hardware and parts are drawn larger in order to more readily identify them.

Each tractor has its own model number.

The model number for your tractor can be found on the fender under the seat.

When ordering parts, always give the following information:

- Product - "TRACTOR"
- MODEL NUMBER - "YT46LS" (96043016701)"
- Part Number
- Part Description

## TABLE OF CONTENTS

SCHEMATIC .....	3
ELECTRICAL.....	4-5
CHASSIS .....	6-7
DRIVE.....	8-9
ENGINE.....	10-11
STEERING .....	12-13
MOWER DECK.....	14-15
MOWER LIFT.....	16
SEAT .....	17
DECALS.....	18

## COMO UTILIZAR ESTE MANUAL

Este manual está diseñado para brindarle al comprador un medio para identificar las piezas del tractor para cuando necesite hacer el pedido de un repuesto. Las ilustraciones pueden o no representar los ensambles reales; por lo tanto, no se recomienda utilizar este manual como una guía para ensamblar o desarmar el tractor. Algunos accesorios y piezas están dibujados en tamaños más grandes para identificarlos con mayor facilidad.

Cada tractor tiene su propio número de modelo.

El número de modelo del tractor se encuentra en el guardabarros debajo del asiento.

Cuando haga el pedido de una pieza, siempre brinde la siguiente información:

- Producto: "TRACTOR"
- NÚMERO DE MODELO: "YT46LS" (96043016701)"
- Número de pieza
- Descripción de la pieza

## ÍNDICE

DIAGRAMA.....	19
DIAGRAMA ELÉCTRICO .....	20-21
CHASIS.....	22-23
TRANSMISIÓN .....	24-25
MOTOR.....	26-27
DIRECCIÓN .....	28-29
PLATAFORMA DE LA CORTADORA DE CÉSPED.....	30-31
ELEVACIÓN DE LA CORTADORA DE CÉSPED.....	32
ASIENTO.....	33
CALCOMANÍAS.....	34

# TRACTOR - MODEL NO. YT46LS (96043016701), PRODUCT NO. 960 43 01-67 SCHEMATIC

SCH13

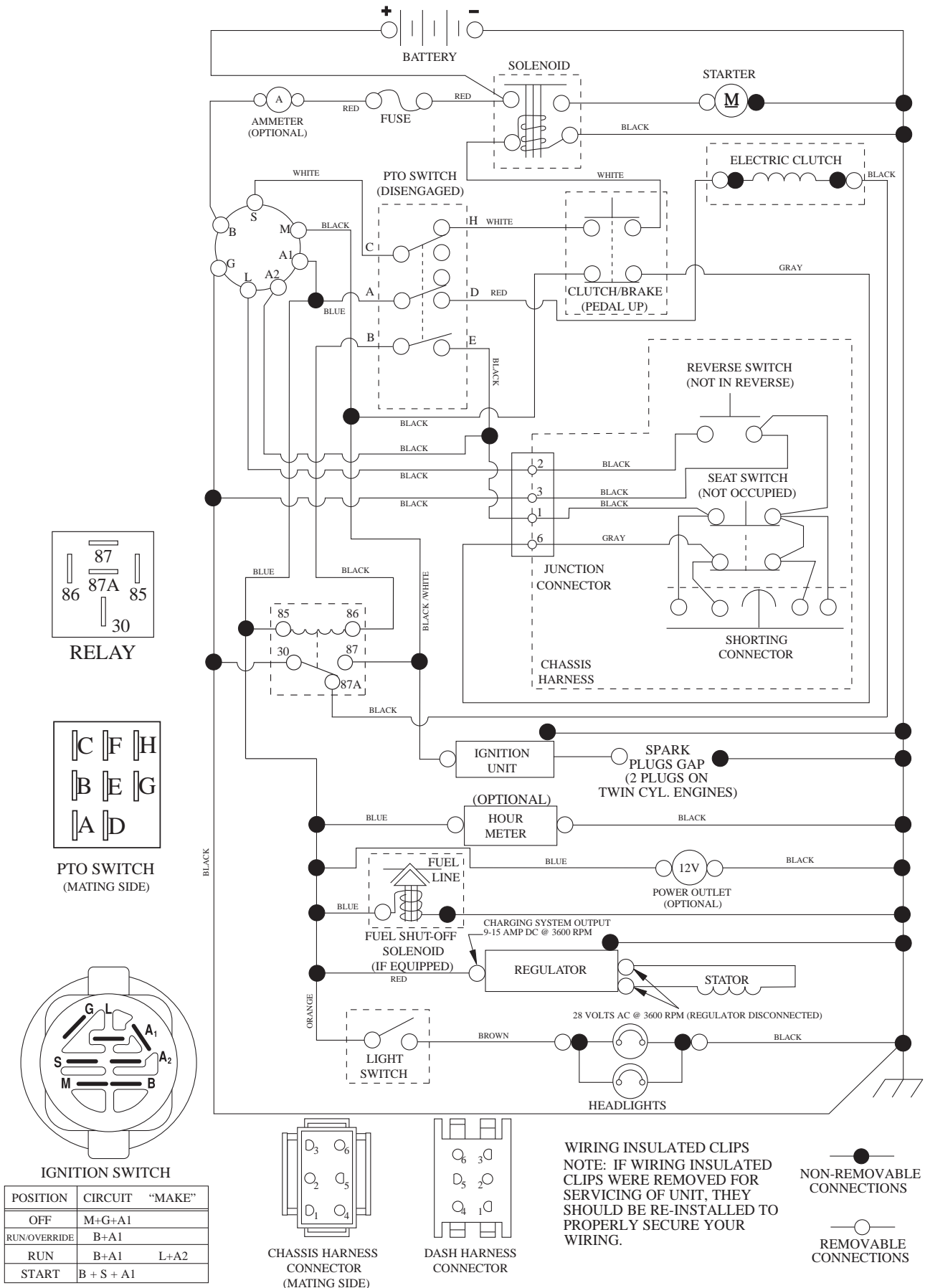

**TRACTOR - MODEL NO. YT46LS (96043016701), PRODUCT NO. 960 43 01-67  
ELECTRICAL**

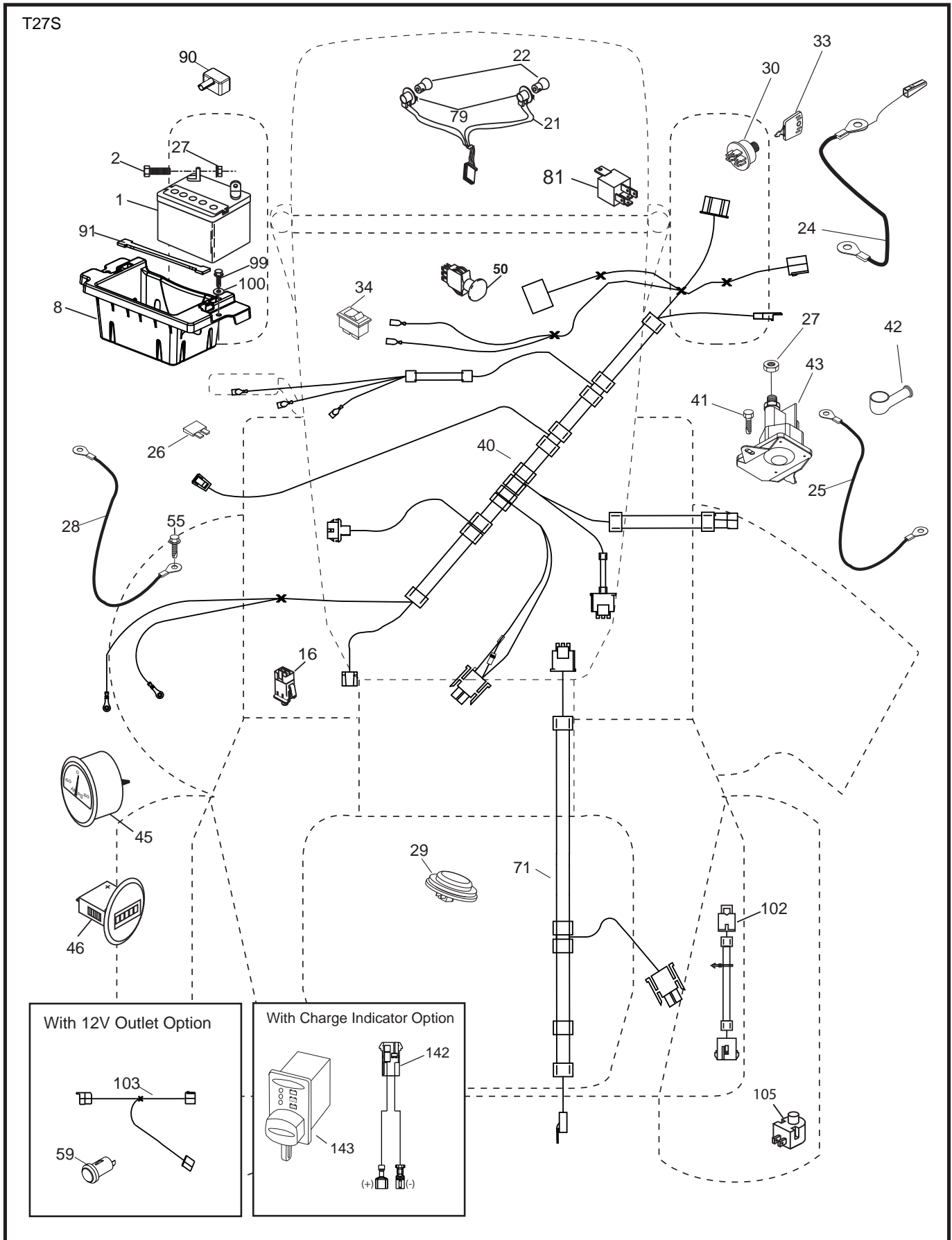

**TRACTOR - MODEL NO. YT46LS (96043016701), PRODUCT NO. 960 43 01-67  
ELECTRICAL**

<b>KEY NO.</b>	<b>PART NO.</b>	<b>DESCRIPTION</b>
1	532 16 34-65	Battery
2	874 76 04-12	Bolt Hex Head 1/4-20 x 3/4
8	532 18 64-91	Box Battery
16	532 17 61-38	Switch Interlock Push-In
21	532 40 02-52	Harness Socket Light w/4152J
22	532 00 41-52	Bulb Light
24	532 40 02-53	Cable Battery
25	532 41 28-95	Cable Starter
26	532 17 51-58	Fuse
27	873 51 04-00	Nut Keps Hex 1/4-20 unc
28	532 14 54-91	Cable, Ground
29	532 40 15-45	Switch, Seat
30	532 19 33-50	Switch, Ign
33	532 41 19-33	Key\Chain
34	532 11 07-12	Switch Light / Reset
40	581 68 71-01	Harness Ign. Dash
41	817 72 04-08	Screw Thd Cut 1/4-20 x 1/2
42	532 13 15-63	Cover, Terminal
43	532 19 25-07	Solenoid
45	532 42 52-70	Ammeter Gauge Round
46	532 42 52-71	Gauge Servicere minder Hrmtr
50	532 17 46-51	Switch PTO
55	817 06 05-12	Screw Thdrol 5/16-18 x 3/4 TYTT
59	532 40 03-03	Outlet 12-Volt
71	532 19 42-76	Harness Ign. Chassis
79	532 17 52-42	Socket Asm Bulb Twistlock
81	532 40 96-15	Relay Harness
90	532 43 53-95	Cover Terminal
91	532 19 02-70	Strap Battery Mount
99	817 67 04-12	Screw Hexwsh Thdrol 1/4-20 x 3/4
100	819 09 14-16	Washer 9/32 x 7/8 x 16 Ga.
102	532 40 44-54	Harness Pigtail
103	532 42 17-47	Harness 12-Volt Pigtail
105	532 40 75-68	Switch Reverse TT Pedal Control
142	532 44 80-57	Harness Charge Port
143	580 36 64-01	Battery Indicator/Charging Plug

**NOTE:** All component dimensions given in U.S. inches  
1 inch = 25.4 mm

# TRACTOR - MODEL NO. YT46LS (96043016701), PRODUCT NO. 960 43 01-67 CHASSIS

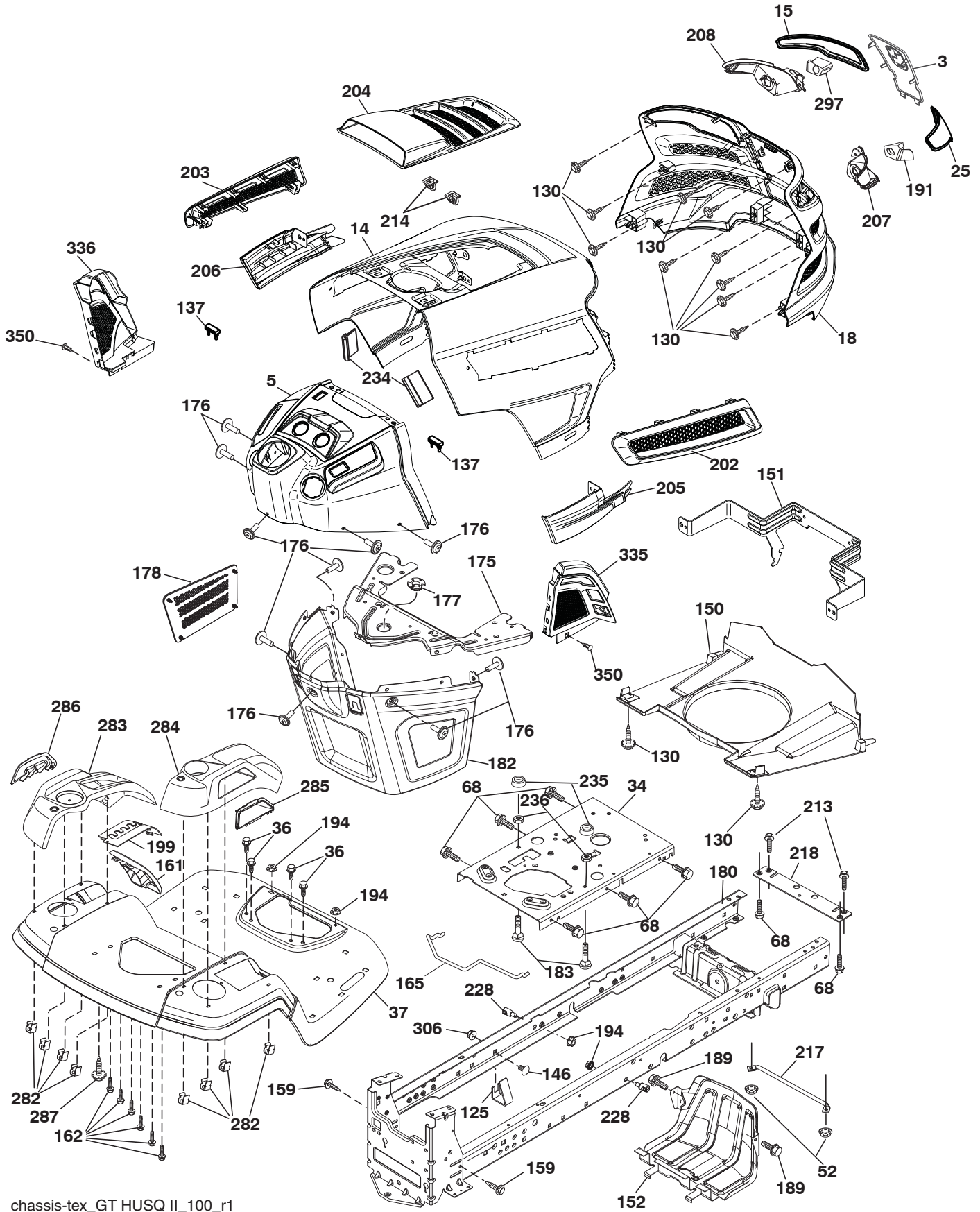

chassis-tex\_GT HUSQ II\_100\_r1

**TRACTOR - MODEL NO. YT46LS (96043016701), PRODUCT NO. 960 43 01-67  
CHASSIS**

KEY NO.	PART NO.	DESCRIPTION
3	532 43 97-52	Applique
5	532 43 74-90	Dash
14	532 44 11-77	Hood
15	532 43 97-33	Lens LH
18	532 43 77-62	Grille/Lens Asm.
25	532 44 33-85	Lens RH
34	580 91 08-01	Plate Engine
36	817 06 05-12	Screw 5/16-18 x 3/4
37	532 44 11-78	Fender
52	873 68 05-00	Nut Crown Lock
68	817 49 05-08	Screw Thdrol 5/16-18 x 1/2
125	581 68 48-01	Clip Fuel Line
130	532 41 63-58	Screw 10 x 0.750 BOS Thread
137	532 40 75-90	Bumper Dash
146	581 85 79-01	Bolt
150	532 43 97-74	Air Duct
151	532 43 66-70	Bracket Pivot Hood
152	532 43 98-70	Shield Browning
159	817 00 06-12	Screw 3/8-16 x 3/4
161	532 43 97-81	Window Fuel
162	532 14 24-32	Screw Hex Wsh Hi-Lo 1/4 x 1/2 unc
165	532 19 68-26	Support Tank Rear
175	532 19 63-04	Crossmember
176	532 40 07-76	Screw 10-24 x 5/8
177	532 19 52-27	Bushing Steering
178	532 19 97-82	Cargo Net Asm.
180	532 19 54-57	Chassis
182	532 40 68-59	Dash Lower
183	874 52 05-20	Bolt 5/16-18 x 1-1/4
189	817 00 06-12	Screw 5/16-18 x 3/4
191	532 43 74-55	Insert Reflective RH
194	873 90 05-00	Nut Lock Hex Flange 5/16-18
199	532 41 34-85	Plate Deck Lift

KEY NO.	PART NO.	DESCRIPTION
202	532 43 97-28	Vent Side Hood RH
203	532 43 97-27	Vent Side Hood LH
204	532 43 57-14	Vent Top Hood
205	532 43 97-30	Side Trim RH
206	532 43 97-29	Side Trim LH
207	532 43 97-34	Bezel RH
208	532 43 97-35	Bezel LH
213	874 76 05-12	Bolt 5/16-18 x 3/4
214	532 19 91-45	Clip Retainer Tinner
217	532 40 91-67	Rod Pivot
218	532 19 63-95	X-Piece Hood Stop
228	532 19 51-61	Stud Fastener
234	532 40 47-42	Bumper Hood
235	532 40 61-29	Spacer Fender
236	873 93 05-00	Nut Lock 5/16-18 unc
282	532 41 41-10	Clip Retainer Console
283	532 43 98-61	Console Deck Lift
284	532 43 98-23	Console Shift
285	532 41 63-15	Console Insert RH
286	532 41 63-17	Console Insert LH
287	817 60 04-06	Screw 1/4-20 X 3/8
297	532 43 74-56	Insert Reflective LH
306	873 90 06-00	Nut Lock
335	532 44 82-04	Cover-RH Lower
336	532 44 53-09	Cover-LH Lower
350	532 44 51-43	Clip X-mas Tree
--	532 43 18-82	Guard Brush

**NOTE:** All component dimensions given in U.S. inches  
1 inch = 25.4 mm





**TRACTOR - MODEL NO. YT46LS (96043016701), PRODUCT NO. 960 43 01-67  
DRIVE**

KEY NO.	PART NO.	DESCRIPTION	KEY NO.	PART NO.	DESCRIPTION
1	---	Transaxle, TUFFTORQ K46CR(426121)(Order parts from transaxle manufacturer.)	184	532 44 14-55	Handle Parking Brake
2	532 12 35-83	Key	185	872 11 06-22	Bolt Rdhd Sqnk 3/8-16 x 2-1/2
15	819 13 13-16	Washer 13/32 x 13/16 x 16 Ga.	186	532 19 43-21	Spacer Retainer
17	532 41 36-78	Spring, Brake	187	819 13 32-10	Washer
26	532 19 96-79	Spring Return Cruise	188	532 19 43-23	Link Clutch Ground Drive
29	532 40 38-06	Rod, Brake	189	532 19 43-17	Bellcrank Ground Drive
33	812 00 00-01	Ring E	190	532 19 43-18	Keeper Bellcrank Ground Drive
35	583 86 45-01	Rod, Brake, Park	196	817 00 06-16	Screw 3/8-16 x 1
42	532 12 48-72	Cover, Foot Pedal	197	532 19 58-04	Bracket Clutch Anti-Rotation
49	872 11 06-14	Bolt	205	532 12 17-48	Washer
50	532 19 43-27	Pulley Idler Flat	206	532 44 85-96	Bracket Mount Latch Cruise
51	873 90 06-00	Lock Nut 3/8-16	207	532 19 78-68	Latch Control Cruise
52	532 19 43-26	Idler V-Groove	208	532 19 78-69	Gear Sector Control Cruise
56	532 13 09-69	V-Belt, Drive	209	532 19 95-92	Rod Control Cruise
64	532 19 78-65	Shaft Asm. Pedal Brake Control	210	532 40 09-80	Rocker Asm. Pedal Control
73	874 49 05-40	Bolt Hex 5/16-18 x 2-1/2 Gr. 5	211	532 12 01-83	Bearing Nylon
80	532 44 06-19	Strap Torque	213	532 40 31-19	Knob Control Cruise
92	874 76 05-20	Bolt Fin Hex 5/16-18 unc x 1.25	214	532 41 68-63	Pedal Forward
99	532 41 57-42	Rod Spring Bypass	215	532 40 17-23	Pedal Reverse
116	873 90 05-00	Nut Lock Hex Flange 5/16-18	216	532 19 61-31	Bracket
125	817 00 05-12	Screw 5/16-18 x 3/4	221	532 40 31-87	Retainer Spring Clip Handle
143	817 49 05-08	Screw 5/16-18 x 1/2	222	879 21 20-10	Washer 21/32 x 1-1/4 x 10 Ga.
153	532 12 47-88	Retainer Spring	225	532 40 33-19	Keeper Belt Trans.
159	876 02 04-12	Pin Cotter 1/8 x 3/4	226	532 40 15-64	Bracket Mount Torque
160	532 16 94-84	Retainer Clip	227	817 49 05-12	Screw 5/16-18 x 3/4
161	532 10 57-09	Spring, Return, Clutch	230	532 18 89-67	Washer Hardened
163	532 44 82-75	Rod Pedal Control	284	532 41 76-93	Nut U-CHNL 1/4-20
166	532 42 91-64	Nut Push	307	874 18 04-12	Screw Mach. 1/4-20 3/4
167	532 40 52-57	Latch Brake Parking			
170	532 19 43-22	Keeper Belt Centerspan			
171	872 11 06-16	Bolt 3/8-16 unc			
183	532 13 70-57	Spacer Split			

**NOTE:** All component dimensions given in U.S. inches  
1 inch = 25.4 mm



**TRACTOR - MODEL NO. YT46LS (96043016701), PRODUCT NO. 960 43 01-67  
ENGINE**

<b>KEY NO.</b>	<b>PART NO.</b>	<b>DESCRIPTION</b>
1	---	Engine Kawa Model No.FR651-AS28 (581411101) (Order parts from engine manufacturer.)
2	532 44 59-62	Muffler
9	584 90 80-01	Keeper Belt Engine
11	532 40 00-08	Clutch Electric
12	532 40 50-97	Pulley Engine
14	532 14 84-56	Tube Drain Oil Easy
15	532 43 80-80	Tank Fuel
18	532 43 92-08	Cap
20	532 42 43-41	Control Throttle
21	532 41 63-58	Screw #10 x .750 BOS Thread
22	532 18 95-41	Control Choke
28	532 40 11-35	Fuel Line
29	532 13 71-80	Spark Arrester Kit
37	532 12 34-87	Clamp Hose
41	532 12 61-97	Washer 1-1/2 OD x 15/32 ID x .250
42	810 04 07-00	Washer Lock 7/16
45	873 51 04-00	Nut Keps Hex 1/4-20 unc
62	532 43 40-17	Shield Heat
69	532 17 81-51	Gasket
70	583 95 56-01	Tube Exhaust LH
71	583 95 57-01	Tube Exhaust RH
85	532 17 39-37	Bolt Hex 7/16-20 x 4 x Gr. 5-1.5 Thr
86	532 18 43-62	Nut Hex Flange Toplock M8-1.25
87	537 17 18-77	Bolt 5/16-18 unc x 3/4 w/Sems
90	817 00 06-16	Screw 3/8-16 x 1
91	532 18 74-95	Bushing
92	817 12 06-16	Screw 3/8-16 x 1
116	539 13 26-24	Knob Shift

**NOTE:** All component dimensions given in U.S. inches  
1 inch = 25.4 mm

For engine service and replacement parts, call the toll free  
number for your engine manufacturer listed below:

Kawasaki 1-949-460-5688

**TRACTOR - MODEL NO. YT46LS (96043016701), PRODUCT NO. 960 43 01-67**  
**STEERING ASSEMBLY**

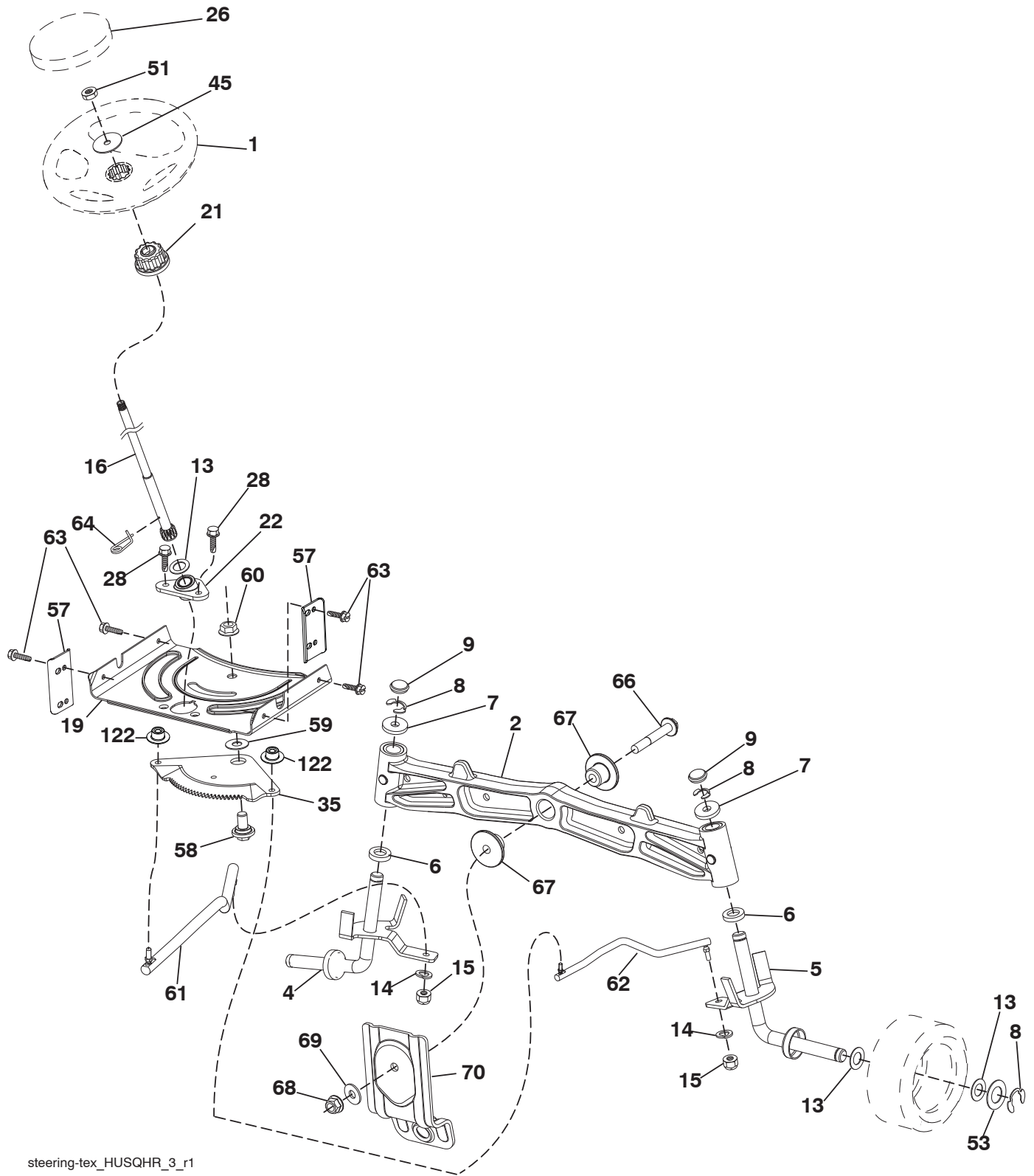

steering-tex\_HUSQHR\_3\_r1

**TRACTOR - MODEL NO. YT46LS (96043016701), PRODUCT NO. 960 43 01-67  
STEERING ASSEMBLY**

<b>KEY NO.</b>	<b>PART NO.</b>	<b>DESCRIPTION</b>
1	532 43 97-40	Wheel, Steering
2	532 19 59-68	Axle Asm., Front
4	532 40 30-87	Spindle Asm., LH
5	532 40 30-88	Spindle Asm., RH
6	532 12 49-31	Bearing, Race Thrust Harden
7	532 12 17-48	Washer 25/32 x 1-5/8 x 16 Ga.
8	812 00 00-29	Ring, Klip #T5304-75
9	532 12 12-32	Cap, Spindle
13	532 12 17-49	Washer 25/32 x 1-1/4 x 16 Ga.
14	810 04 06-00	Washer, Lock Hvy Hlcl Spr 3/8
15	873 54 06-00	Nut, Crown Lock 3/8-24 unf
16	532 40 82-19	Shaft Steering
19	532 19 47-29	Plate Steering
21	532 18 67-37	Adapter, Wheel Steering
22	532 42 05-37	Strg. Supt. Lower
26	532 43 97-43	Insert, Wheel Steering
28	817 00 06-12	Screw 3/8-16 x 3/4
35	532 19 47-32	Gear, Sector Plate
45	819 18 38-12	Washer 9/16 ID x 2-3/8 OD 12 GZIN
51	873 94 08-00	Nut Hex Jam Toplock 1/2-20
53	532 18 89-67	Washer Hardened .793 x 1.637 x .060
57	532 40 74-65	Bracket Upstop
58	532 19 47-47	Bolt Shoulder Sector Pivot CFM
59	532 19 47-48	Washer Thrust Sector Steering
60	873 97 10-00	Nut Flange Lock 5/8-11
61	532 19 47-40	Draglink, LH
62	532 19 47-41	Draglink, RH
63	817 00 05-12	Screw 5/16-18 x 3/4
64	532 19 98-49	Retainer Clip Spring Steering
66	871 02 07-48	Bolt Hex Fghd 7/16-14 x 3 Serr
67	532 19 47-37	Bushing PM Front Axle
68	873 90 07-00	Nut Lock Flange 7/16-14 Gr. 5
69	532 19 91-62	Washer 1.5 x .505 x .118
70	532 19 61-97	Bracket Deck Susp. Front
122	532 44 49-62	Cap Gear Sector

**NOTE:** All component dimensions given in U.S. inches  
1 inch = 25.4 mm

TRACTOR - MODEL NO. YT46LS (96043016701), PRODUCT NO. 960 43 01-67  
MOWER DECK

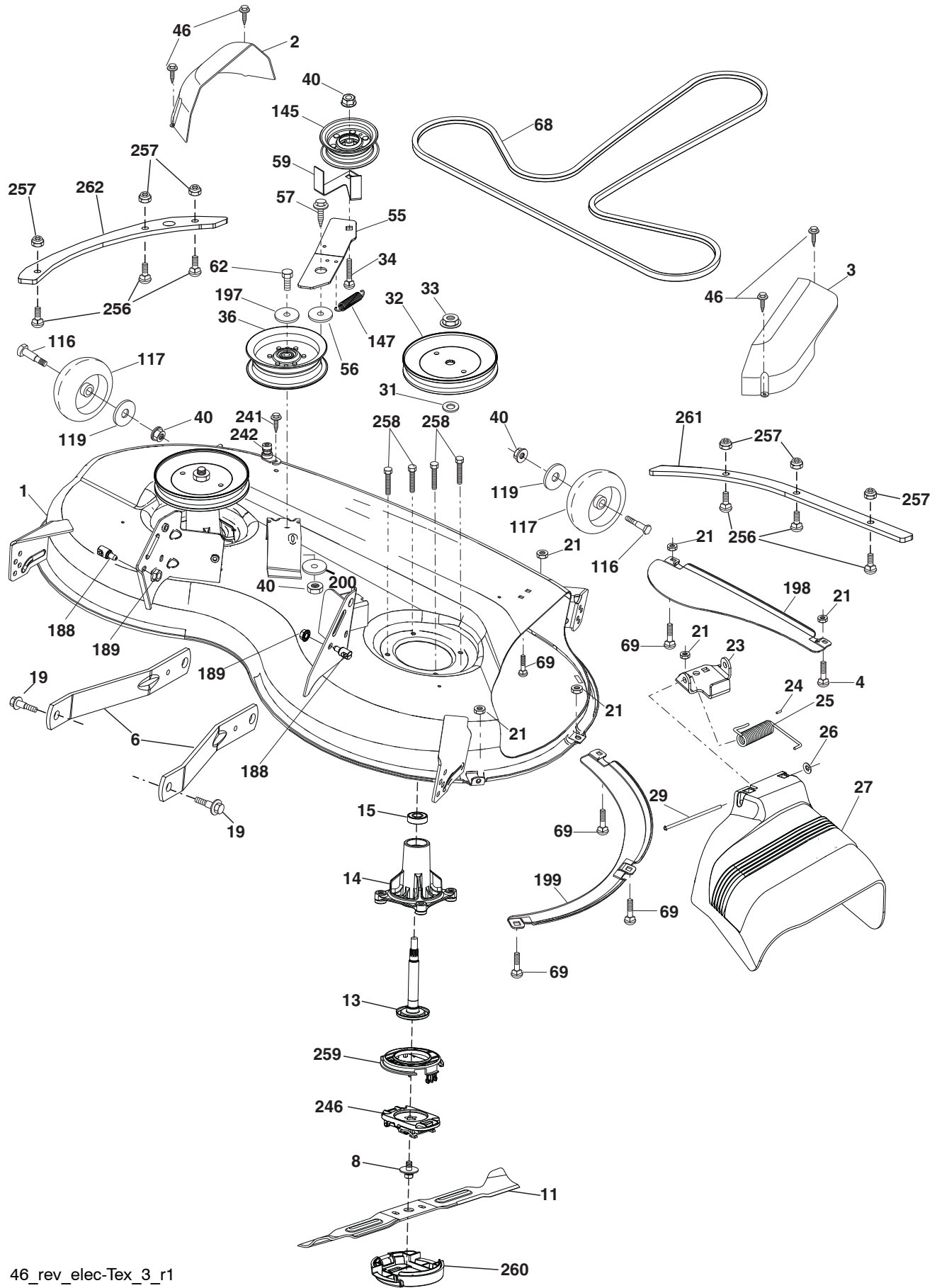

46\_rev\_elec-Tex\_3\_r1

**TRACTOR - MODEL NO. YT46LS (96043016701), PRODUCT NO. 960 43 01-67  
MOWER DECK**

<b>KEY NO.</b>	<b>PART NO.</b>	<b>DESCRIPTION</b>	<b>KEY NO.</b>	<b>PART NO.</b>	<b>DESCRIPTION</b>
1	583 90 09-02	Mower Housing	117	532 17 48-73	Wheel, Gauge
2	532 40 55-07	Cover Mandrel LH	119	819 13 20-12	Washer 13/32 x 1-1/2 x 11 Ga.
3	532 40 55-06	Cover Mandrel RH	145	532 19 31-97	Pulley Idler
4	874 76 05-12	Bolt Hex Hd 5/16-18 unc	147	532 19 72-51	Spring Return
6	532 19 51-86	Arm Suspension	188	532 19 51-61	Stud Fastener
8	584 30 93-01	Screw	189	873 90 05-00	Nut Lock Hex Flange
11	581 04 39-01	Blade Mower	197	819 13 13-12	Washer 13/32 x 13/16 x 12 Ga.
13	580 85 47-01	Shaft Asm. Rev. Tall	198	532 40 31-49	Baffle Center Front
14	580 79 61-01	Housing, Mandrel	199	532 40 31-50	Baffle Front RH
15	532 11 04-85	Bearing, Ball, Mandrel	200	532 41 35-24	Washer 13/32 x 1 x 1/2 11 Ga.
19	532 19 65-39	Bolt, Shoulder	241	532 15 29-27	Screw
21	873 68 05-00	Nut	242	532 41 55-98	Washout Port
23	532 19 25-57	Bracket, Deflector	246	580 95 40-02	Blade Holder
24	532 10 53-04	Cap, Sleeve	256	578 29 64-04	Screw Buttonhead 5/16-18
25	532 19 70-26	Spring, Torsion, Deflector	257	873 90 04-00	Nut Hex Flange 1/4-20 unc
26	532 11 04-52	Nut, Push	258	584 95 39-01	Bolt Hex Washer Head 3/8-18 x 1.19
27	532 40 53-57	Shield, Deflector	259	584 30 66-01	Cap Revolution Upper
29	532 13 14-91	Rod, Hinge	260	584 30 67-01	Cap Revolution Lower
31	532 18 76-90	Washer, Spacer	261	581 96 77-05	Plate Reinforcement Front
32	532 19 74-73	Pulley, Mandrel	262	581 96 78-05	Plate Reinforcement Side
33	532 40 02-34	Nut, Toplock, Flanged	--	532 41 64-05	Coupling Quick Connect
34	872 11 06-12	Bolt Carr Sh. 3/8-16 x 1-1/2 Gr. 5	--	580 85 60-01	Mandrel Assembly-Tall (Includes Housing (Key #14), Shaft Assembly (Key #13), and Bearing Only (Key #15) Pulley/Nut/Washer and Blade Bolt/Washers Not Included)
36	532 19 73-79	Pulley, Idler, Flat			
40	873 90 06-00	Nut, Lock Flg. 3/8-16 unc			
46	532 13 77-29	Screw			
55	532 19 72-49	Arm, Idler			
56	532 19 90-92	Spacer, Retainer	--	581 74 54-01	Replacement Mower, Complete
57	817 00 06-16	Screw Hexwsh Thd 3/8-16 x 1			
59	532 14 10-43	Guard, Tuv Idler (94)			
62	874 52 06-36	Bolt 3/8-16 unc x 2-1/4 Gr. 5			
68	532 40 51-43	V-Belt			
69	872 14 05-05	Bolt			
116	532 19 34-06	Bolt, Shoulder			

**NOTE:** All component dimensions given in U.S. inches  
1 inch = 25.4 mm

**TRACTOR - MODEL NO. YT46LS (96043016701), PRODUCT NO. 960 43 01-67  
MOWER LIFT**

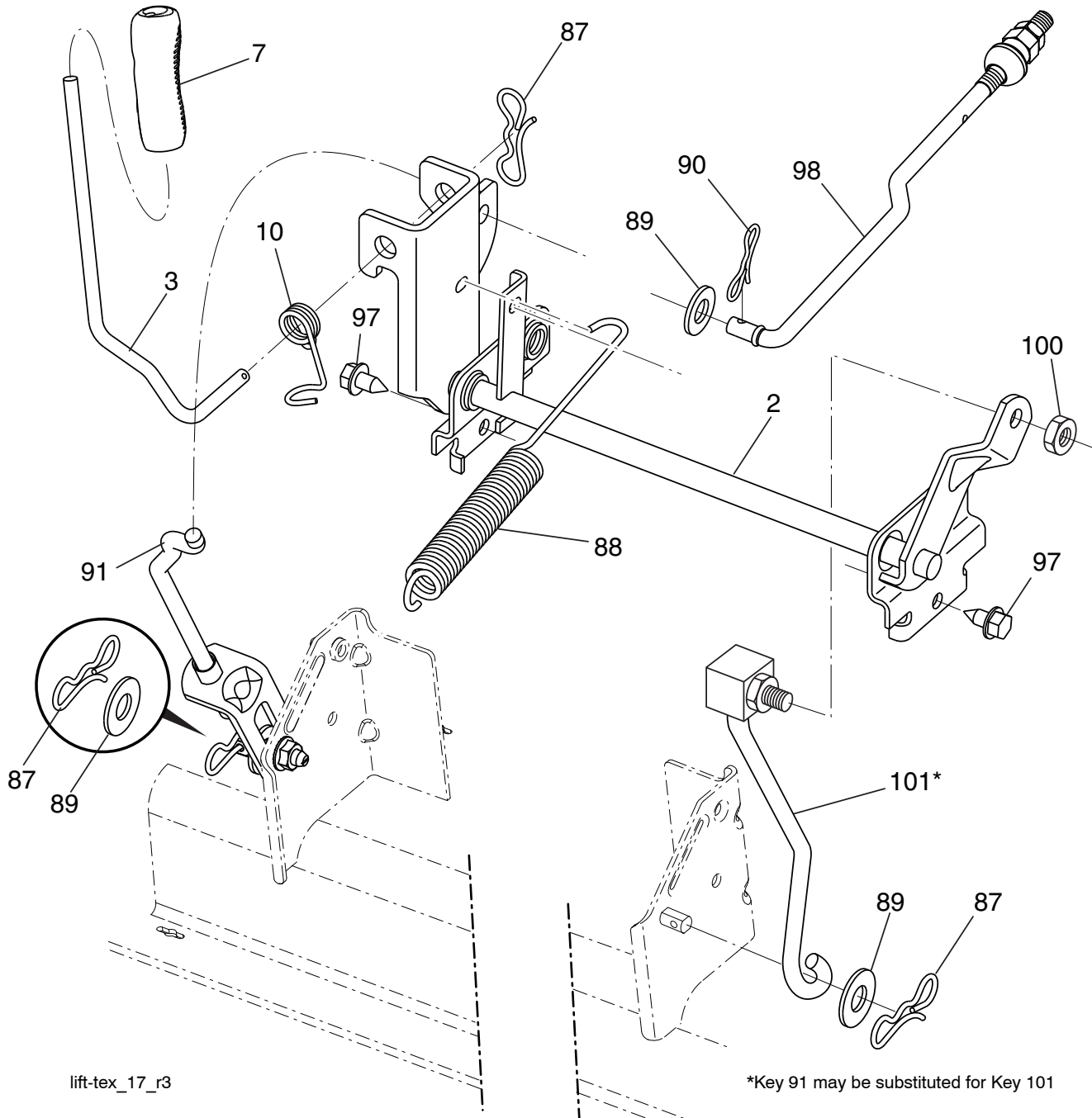

lift-tex\_17\_r3

\*Key 91 may be substituted for Key 101

KEY NO.	PART NO.	DESCRIPTION
2	532 42 20-27	Shaft Asm., Lift
3	532 19 52-31	Lever Asm., Lift RH
7	580 96 23-01	Grip, Lever
10	532 19 63-14	Spring Torsion
87	532 19 42-09	Pin Cotter 7/16 Bow Tie Lock
88	532 41 07-10	Spring Lift Assist
89	819 19 19-12	Washer Clear Zinc
90	532 19 42-08	Pin Cotter 5/16 Bow Tie Lock

KEY NO.	PART NO.	DESCRIPTION
91	532 19 51-81	Link Asm Lift LH Rear
97	817 00 06-12	Screw Hex Wsh. THDR 3/8-16 x 3/4
98	532 19 52-70	Link Lift Susp. Front Mower
100	873 93 06-00	Nut Centerlock 3/8-16 unc
101	532 40 70-03	Link Asm. Lift FXD

**NOTE:** All component dimensions given in U.S. inches  
1 inch = 25.4 mm



**TRACTOR - MODEL NO. YT46LS (96043016701), PRODUCT NO. 960 43 01-67  
SEAT ASSEMBLY**

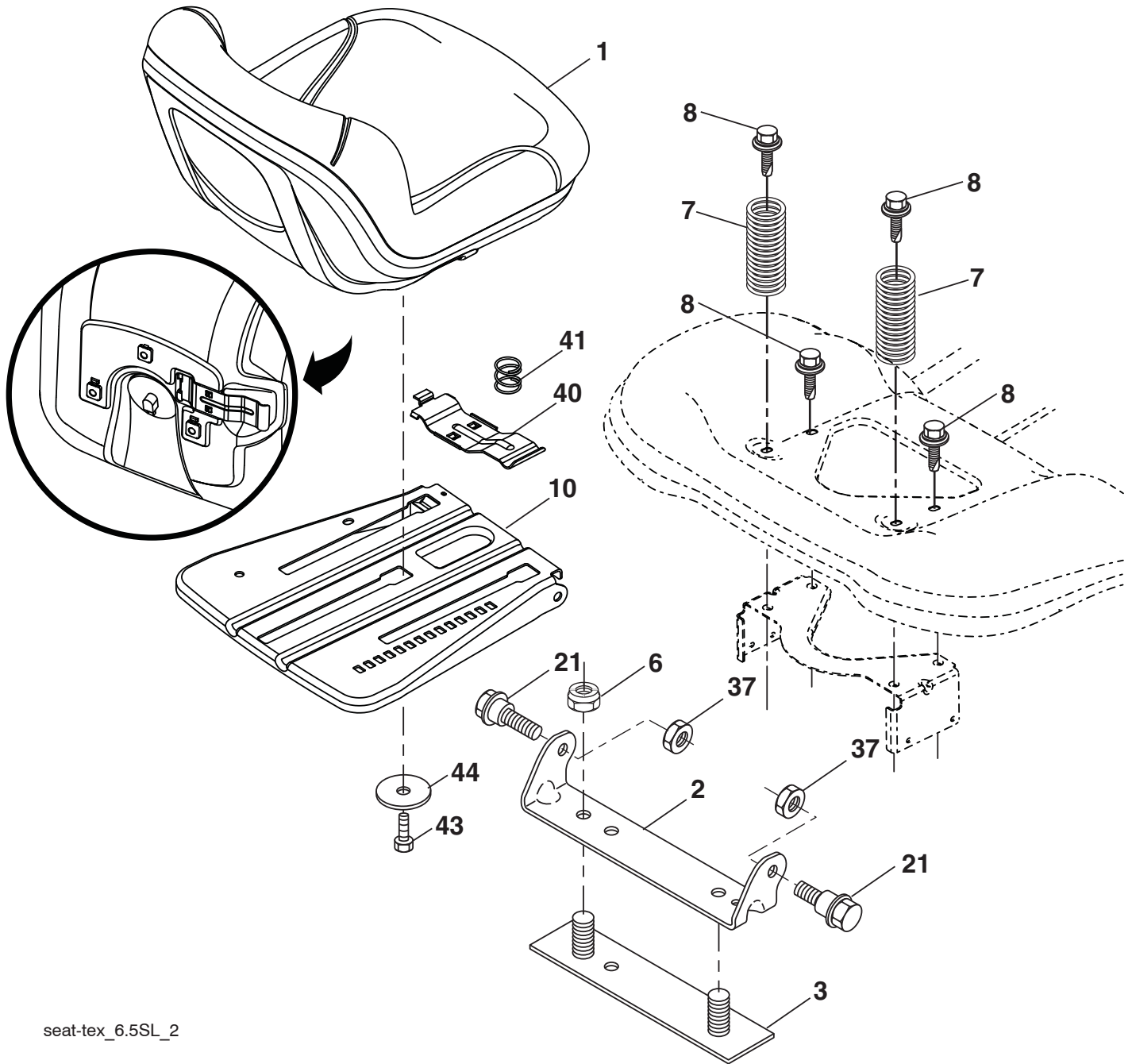

seat-tex\_6.5SL\_2

KEY NO.	PART NO.	DESCRIPTION
1	532 43 98-22	Seat
2	532 18 01-66	Bracket Pivot Fender
3	532 14 06-75	Strap, Asm Fender
6	873 80 06-00	Nut, Lock w/Ins. 3/8-16 unc
7	532 12 41-81	Spring, Seat Cprsn
8	532 17 18-77	Bolt 5/16-18 unc x 3/4 w/Sems
10	532 19 69-77	Pan, Seat
21	532 17 18-52	Bolt, Shoulder 5/16-18

KEY NO.	PART NO.	DESCRIPTION
37	873 80 05-00	Nut, Lock 5/16-18 unc
40	532 43 98-71	Handle Slide Seat
41	532 19 82-00	Spring Latch Seat
43	874 76 06-12	Bolt Fin Hex 3/8-16 unc x 3/4
44	819 13 38-12	Washer 13/32 x 2-3/8 x 12 Ga.

**NOTE:** All component dimensions given in U.S. inches  
1 inch = 25.4 mm

**TRACTOR - MODEL NO. YT46LS (96043016701), PRODUCT NO. 960 43 01-67  
DECALS**

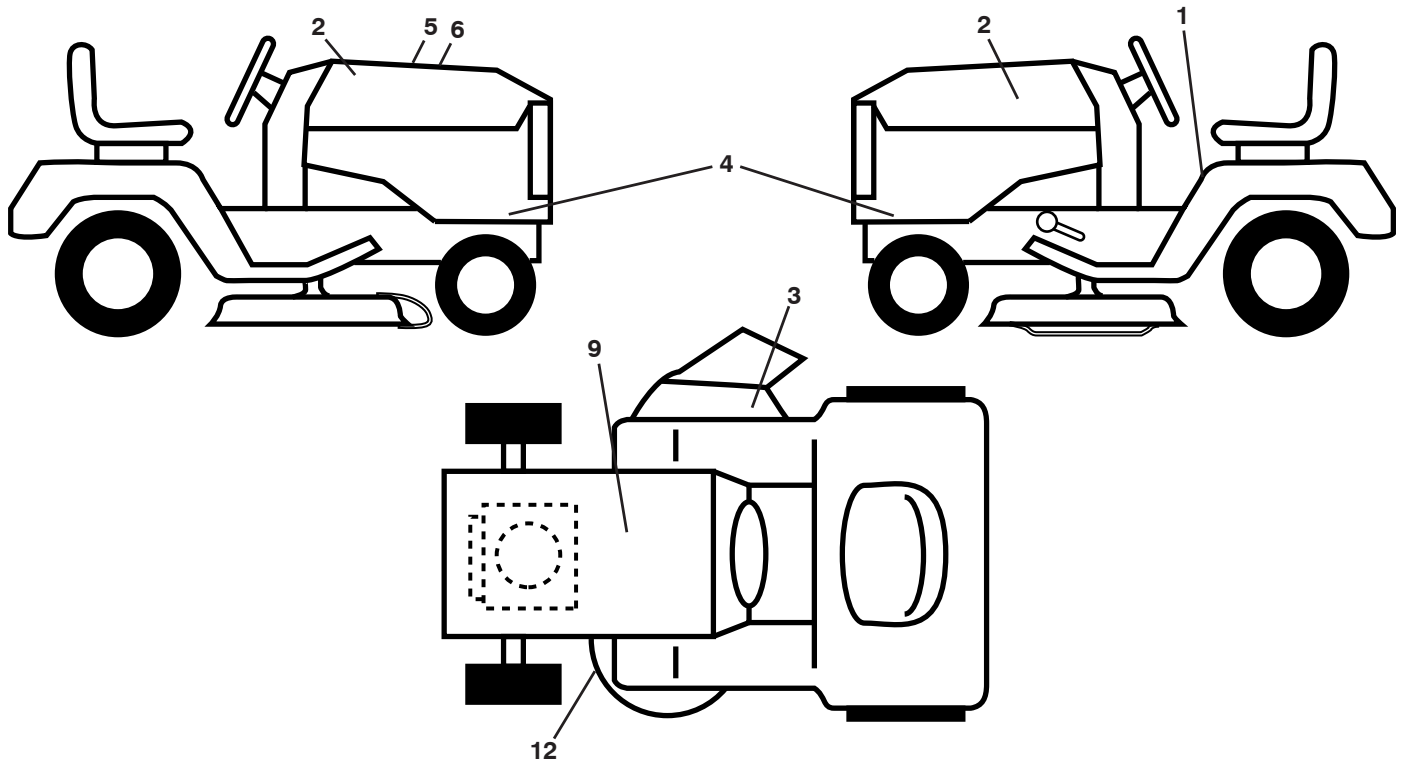

KEY NO.	PART NO.	DESCRIPTION
1	581 57 89-01	Decal, Fender Warn./Instructions
2	581 62 73-01	Decal, Hood Logo
3	581 57 95-01	Decal, Mower Warning
4	581 61 97-01	Decal, Hood Panel
5	532 42 38-29	Decal, Customer Respons.
6	584 47 37-01	Decal, Replacement
9	532 14 50-05	Decal, Battery Dnge/Poi
12	581 58 00-01	Decal, Mower V-Belt Schematic

KEY NO.	PART NO.	DESCRIPTION
--	581 72 48-01	Decal, Bypass
--	532 43 96-81	Pad, Footrest, LH
--	532 43 96-82	Pad, Footrest, RH
--	585 71 44-01	Decal, Pop Armor Protected Deck
--	586 00 01-96	Manual, Operator's (English/Spanish)
--	586 00 01-27	Manual, Parts (English/Spanish)

**WHEELS AND TIRES**

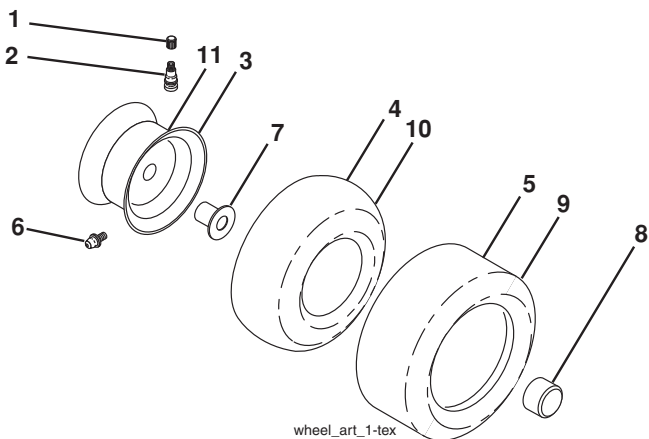

KEY NO.	PART NO.	DESCRIPTION
1	532 05 91-92	Cap Valve Tire
2	532 06 51-39	Stem Valve
3	532 13 83-36	Rim Asm 6" Front
4	532 05 99-04	Tube Front (Service Item Only)
5	532 10 62-22	Tire Front 15 x 6-6
6	532 12 49-57	Fitting Grease (Front Wheel Only)
7	532 12 49-59	Bearing Flange (Front Wheel Only)
8	532 17 50-39	Cap Axle Blk 1 50 x 1 00
9	532 13 84-68	Tire Rear 20 x 8-8
10	532 12 49-26	Tube Rear (Service Item Only)
11	532 13 83-37	Rim Asm 8" Rear
--	532 14 43-34	Sealant, Tire (10 oz. Tube)

**NOTE:** All component dimensions given in U.S. inches  
1 inch = 25.4 mm

# TRACTOR MODELO NO. YT46LS (96043016701), PRODUCTO NO. 960 43 01-67

## DIAGRAMA

SCH13-s

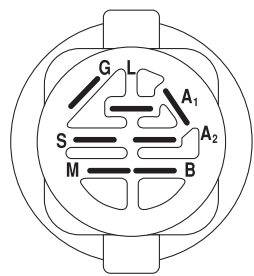
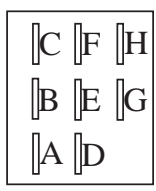
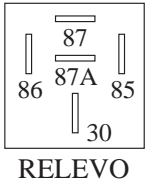
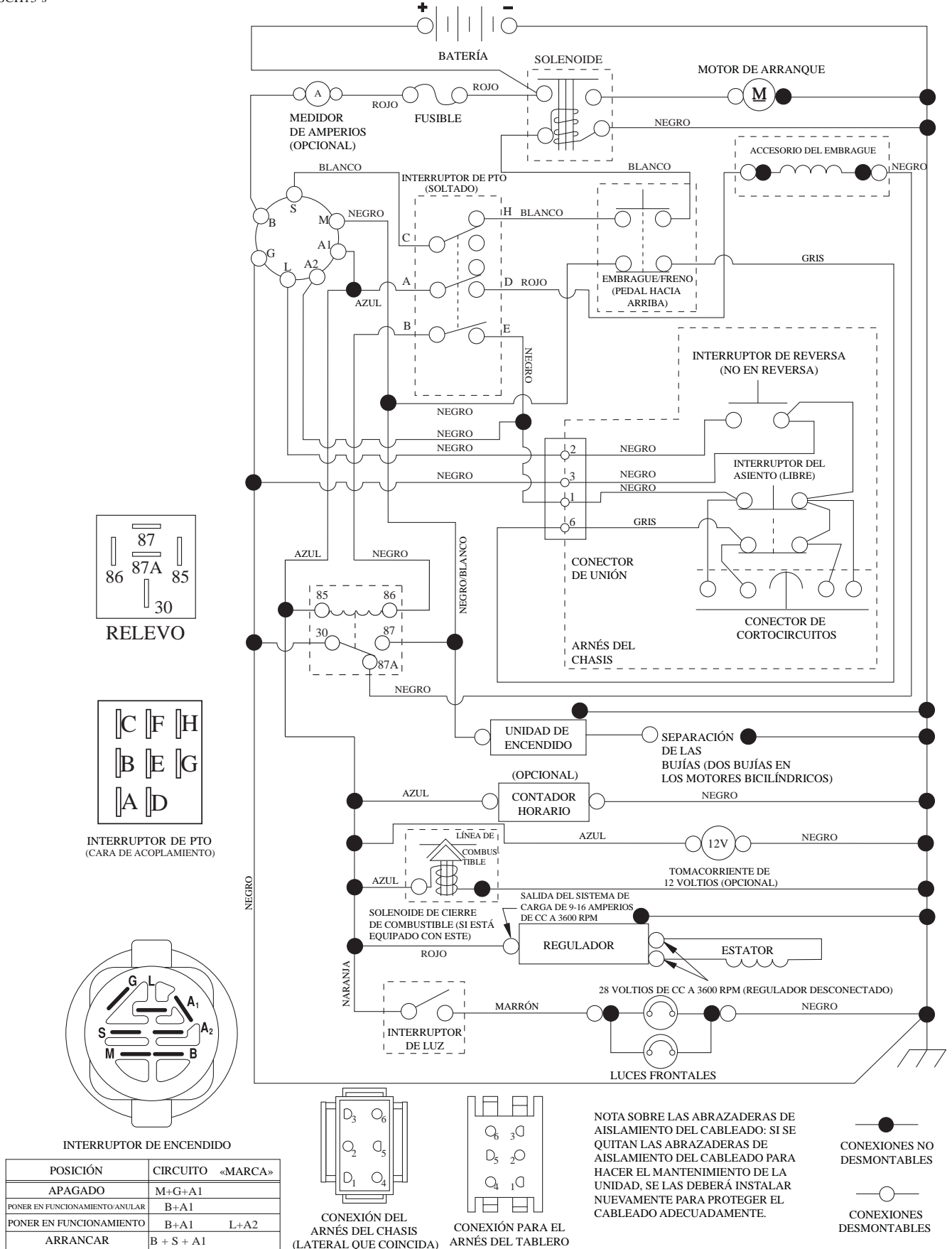

POSICIÓN	CIRCUITO «MARCA»
APAGADO	M+G+A1
PONER EN FUNCIONAMIENTO/ANULAR	B+A1
PONER EN FUNCIONAMIENTO	B+A1 L+A2
ARRANCAR	B + S + A1

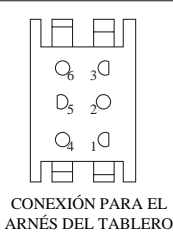
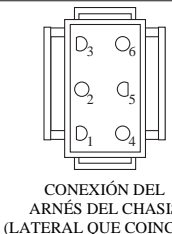

NOTA SOBRE LAS ABRAZADERAS DE AISLAMIENTO DEL CABLEADO: SI SE QUITAN LAS ABRAZADERAS DE AISLAMIENTO DEL CABLEADO PARA HACER EL MANTENIMIENTO DE LA UNIDAD, SE LAS DEBERÁ INSTALAR NUEVAMENTE PARA PROTEGER EL CABLEADO ADECUADAMENTE.



TRACTOR MODELO NO. YT46LS (96043016701), PRODUCTO NO. 960 43 01-67

DIAGRAMA ELÉCTRICO

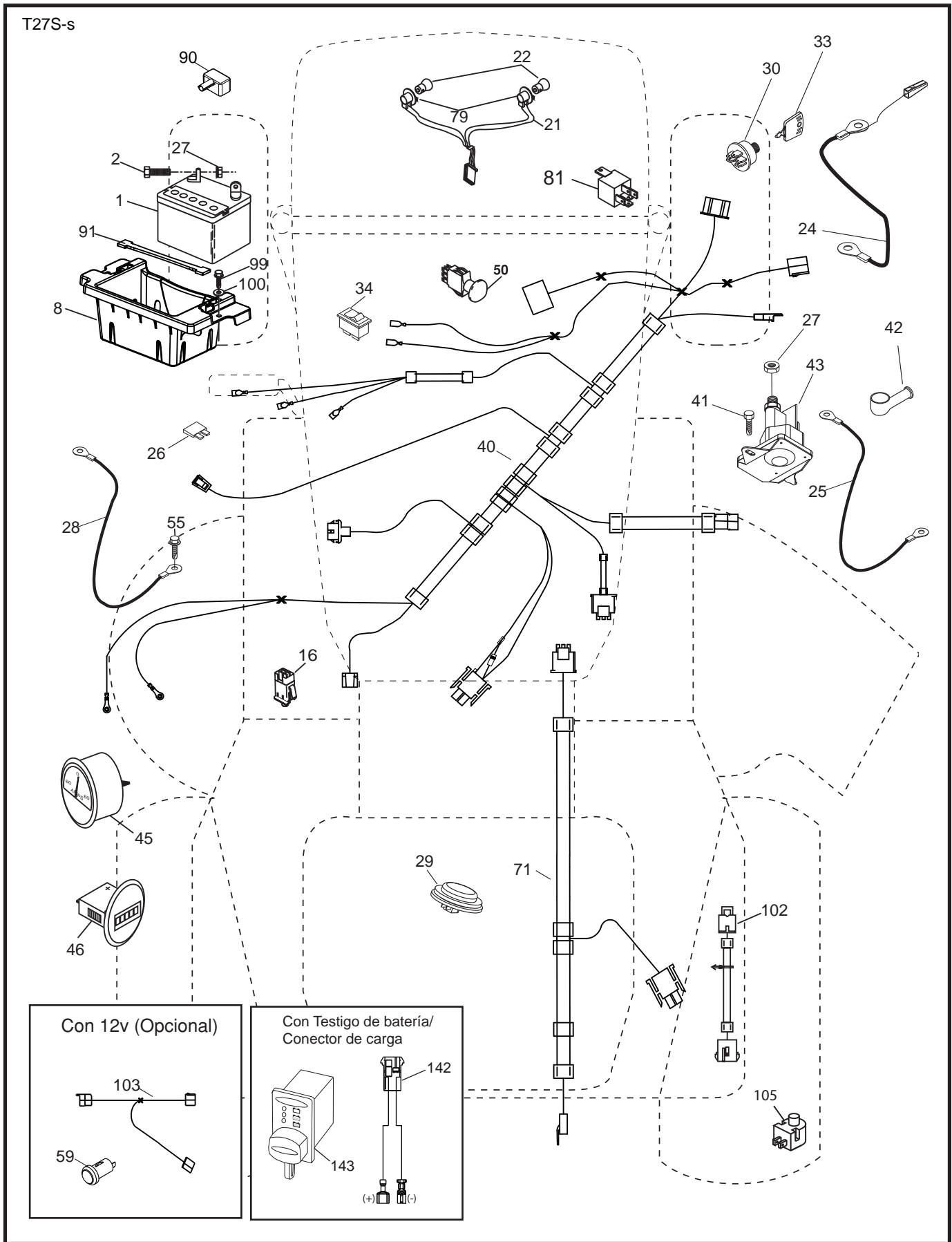

**TRACTOR MODELO NO. YT46LS (96043016701), PRODUCTO NO. 960 43 01-67  
DIAGRAMA ELÉCTRICO**

<b>CÓDIGO NO.</b>	<b>PIEZA NO.</b>	<b>DESCRIPCIÓN</b>
1	532 16 34-65	Batería
2	874 76 04-12	Perno de cabeza hexagonal de 1/4-20 x 3/4
8	532 18 64-91	Caja de la batería
16	532 17 61-38	Interruptor corta corriente a presión
21	532 40 02-52	Cableado del enchufe para la luz
22	532 00 41-52	Bombilla de luz
24	532 40 02-53	Cable
25	532 41 28-95	Cable
26	532 17 51-58	Fusible
27	873 51 04-00	Tuerca hexagonal Keps de 1/4-20 unc
28	532 14 54-91	Cable a tierra
29	532 40 15-45	Interruptor del asiento
30	532 19 33-50	Interruptor de encendido
33	532 41 19-33	Llave/cadena
34	532 11 07-12	Interruptor de luz/de restauración
40	581 68 71-01	Cableado de encendido
41	817 72 04-08	Tornillo
42	532 13 15-63	Cubierta de la terminal
43	532 19 25-07	Solenoides
45	532 42 52-70	Indicador SRVCMNDR
46	532 42 52-71	Indicador HRMTR
50	532 17 46-51	Interruptor
55	817 06 05-12	Tornillo de 5/16-18 x 3/4
59	532 40 03-03	Enchufe, 12V
71	532 19 42-76	Cableado de encendido, chasis
79	532 17 52-42	Enchufe de cierre por torsión del ensamble de la bombilla
81	532 40 96-15	Cableado de relé
90	532 43 53-95	Tapa de los bornes de la batería
91	532 19 02-70	Correa de la batería
99	817 67 04-12	Tornillo 1/4-20 x 3/4
100	819 09 14-16	Arandela
102	532 40 44-54	Cable
103	532 42 17-47	Cable 12V
105	532 40 75-68	Interruptor Reverso
142	532 44 80-57	Cableado de conector de carga
143	580 36 64-01	Testigo de batería/conector de carga

**NOTA:** Las dimensiones de todos los componentes están expresadas en pulgadas americanas. 1 pulgada = 25,4 mm



**TRACTOR MODELO NO. YT46LS (96043016701), PRODUCTO NO. 960 43 01-67  
CHASIS**

<b>CÓDIGO NO.</b>	<b>PIEZA NO.</b>	<b>DESCRIPCIÓN</b>	<b>CÓDIGO NO.</b>	<b>PIEZA NO.</b>	<b>DESCRIPCIÓN</b>
3	532 43 97-52	Aplica	202	532 43 97-28	Salida de Ventilación (LD)
5	532 43 74-90	Tablero	203	532 43 97-27	Salida de Ventilación (LI)
14	532 44 11-77	Capota	204	532 43 57-14	Salida de Ventilación superior
15	532 43 97-33	Lente izquierdo de la parrilla	205	532 43 97-30	Camisa (LD)
18	532 43 77-62	Parrilla	206	532 43 97-29	Camisa (LI)
25	532 44 33-85	Lente derecho de la parrilla	207	532 43 97-34	Bisel derecho
34	580 91 08-01	Placa	208	532 43 97-35	Bisel izquierdo
36	817 06 05-12	Tornillo de 5/16-18 x 3/4	213	874 76 05-12	Perno 5/16-18 x 3/4
37	532 44 11-78	Guardabarros	214	532 19 91-45	Cierre
52	873 68 05-00	Tuerca de presión	217	532 40 91-67	Varilla giratoria
68	817 49 05-08	Tornillo de 5/16-18 x 1/2	218	532 19 63-95	Tope
125	581 68 48-01	Soporte	228	532 19 51-61	Sujetador del travesaño
130	532 41 63-58	Tornillo No. 10 x 0,75	234	532 40 47-42	Cubierta Capota
137	532 40 75-90	Cubierta Tablero	235	532 40 61-29	Separador del guardabarros
146	581 85 79-01	Perno	236	873 93 05-00	Tuerca de presión 5/16-18 unc
150	532 43 97-74	Cubierta	282	532 41 41-10	Pinzas de retención
151	532 43 66-70	Soporte de Capota	283	532 43 98-61	Consola de la plataforma de elevación
152	532 43 98-70	Protector contra oscurecimiento	284	532 43 98-23	Consola cambio
159	817 00 06-12	Tornillo 3/8-16 x 3/4	285	532 41 63-15	Consola inserto (LD)
161	532 43 97-81	Ventanilla de combustible	286	532 41 63-17	Consola inserto (LI)
162	532 14 24-32	Tornillo	287	817 60 04-06	Tornillo 1/4-20 X 3/8
165	532 19 68-26	Soporte de Tanque de Gasolina	297	532 43 74-56	Parte movable reflexivo (LI)
175	532 19 63-04	Travesaño	306	873 90 06-00	Tuerca
176	532 40 07-76	Tornillo de 10-24 x 5/8	335	532 44 82-04	Cubierta de Fermeture (LD)
177	532 19 52-27	Buje de dirección	336	532 44 53-09	Cubierta de Fermeture (LI)
178	532 19 97-82	Red de cargo	350	532 44 51-43	Clip del árbol de navidad
180	532 19 54-57	Chasis	--	532 43 18-82	Protector del cepillo
182	532 40 68-59	Tablero inferior			
183	874 52 05-20	Perno 5/16-18 x 1-1/4			
189	817 00 05-12	Tornillo			
191	532 43 74-55	Parte movable reflexivo (LD)			
194	873 90 05-00	Tuerca de presión de 5/16-18			
199	532 41 34-85	Chapa			

**NOTA:** Las dimensiones de todos los componentes están expresadas en pulgadas americanas. 1 pulgada = 25,4 mm

TRACTOR MODELO NO. YT46LS (96043016701), PRODUCTO NO. 960 43 01-67  
TRANSMISIÓN

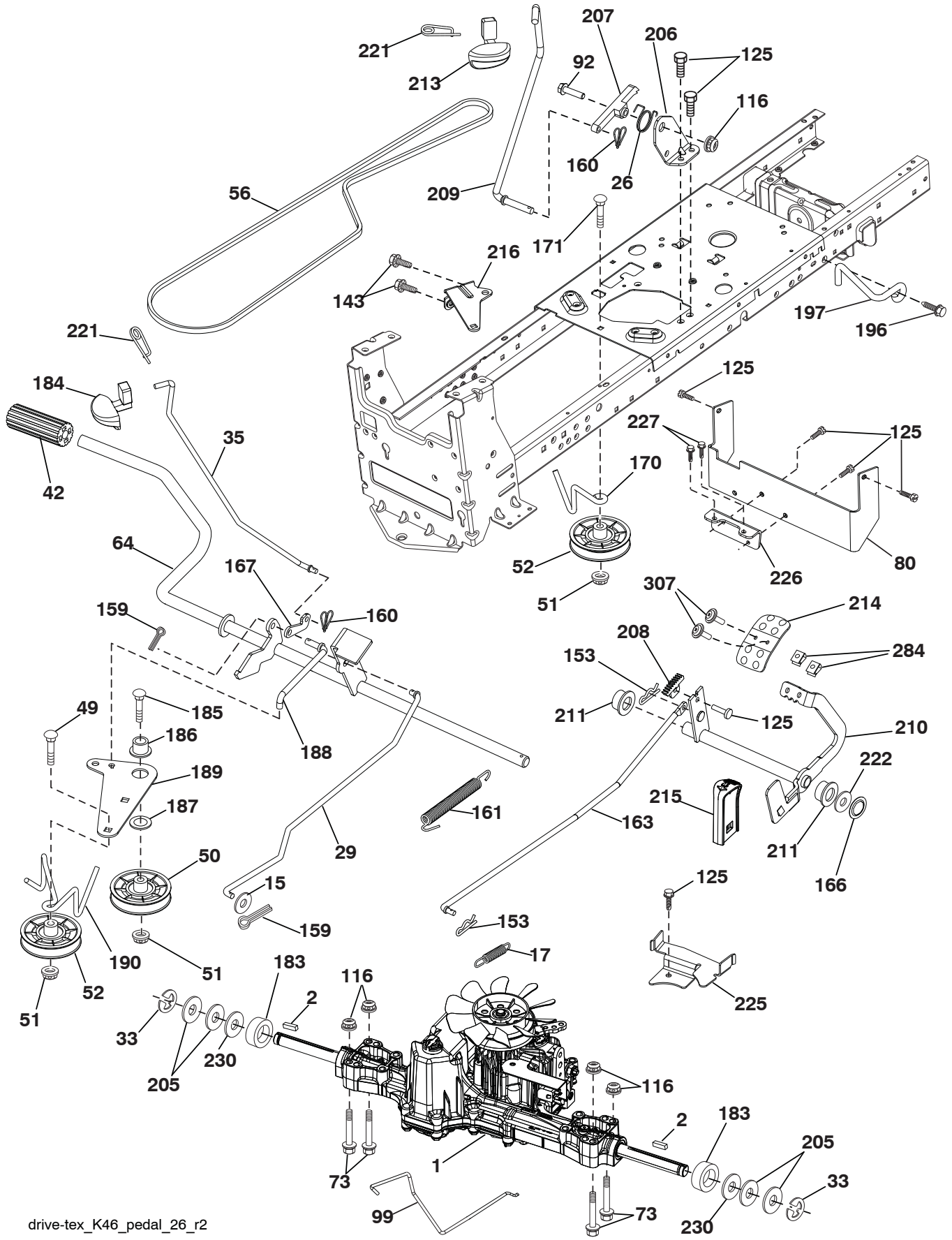

drive-tex\_K46\_pedal\_26\_r2



**TRACTOR MODELO NO. YT46LS (96043016701), PRODUCTO NO. 960 43 01-67**  
**TRANSMISIÓN**

<b>CÓDIGO NO.</b>	<b>PIEZA NO.</b>	<b>DESCRIPCIÓN</b>	<b>CÓDIGO NO.</b>	<b>PIEZA NO.</b>	<b>DESCRIPCIÓN</b>
1	---	Transeje, TUFFTORQ K46 CR (426121)(Haga el pedido de las piezas al fabricante del transeje.)	185	872 11 06-22	Perno 3/8-16 x 2-3/4 G5
2	532 12 35-83	Llave	186	532 19 43-21	Espaciador de retención
15	819 13 13-16	Arandela 13/32 x 13/16 x calibre 16	187	819 13 32-10	Arandela
17	532 41 36-78	Resorte de freno	188	532 19 43-23	Mecanismo de desplazamiento de la varilla de mando del embrague
26	532 19 96-79	Resorte de travesía	189	532 19 43-17	Palanca acodada del mecanismo de desplazamiento
29	532 40 38-06	Varilla del freno	190	532 19 43-18	Sujetador de la palanca acodada del mecanismo de desplazamiento
33	812 00 00-01	Aro "E"	196	817 00 06-16	Tornillo 3/8-16 x 1
35	583 86 45-01	Varilla del freno de mano	197	532 19 58-04	Mecanismo de desplazamiento
42	532 12 48-72	Cubierta del pedal	205	532 12 17-48	Tuerca
49	872 11 06-14	Perno	206	532 44 85-96	Soporte de la travesía
50	532 19 43-27	Polea loca plana	207	532 19 78-68	Cierre del control de travesía
51	873 90 06-00	Tuerca de presión de 3/8-16	208	532 19 78-69	Travesía del control del sector
52	532 19 43-26	Polea loca con ranura en V con un desplazamiento	209	532 19 95-92	Travesía del control de Rod
56	532 13 09-69	Correa trapezoidal de la transmisión	210	532 40 09-80	Asm del eje de balancín. Control del pedal
64	532 19 78-65	Ensamble del eje Control del pedal de freno	211	532 12 01-83	Buje
73	874 49 05-40	Perno 5/16-18	213	532 40 31-19	Travesía del control de la perilla
80	532 44 06-19	Correa de torsión	214	532 41 68-63	Pedal adelante
92	874 76 05-20	Tornillo 5/16-18 x 1/2	215	532 40 17-23	Revés del pedal
99	532 41 57-42	Varilla de desviación	216	532 19 61-31	Soporte
116	873 90 05-00	Tuerca 5/16-18	221	532 40 31-87	Abrazadera de retención del resorte de la manija
125	817 00 05-12	Tornillo 5/16-18 x 3/4	222	879 21 20-10	Tuerca 21/32 x 1-1/4 x calibre 10
143	817 49 05-08	Tornillo 5/16-18 x 1/2	225	532 40 33-19	Sujetador de la correa transeje
153	532 12 47-88	Retén del resorte	226	532 40 15-64	Soporte
159	876 02 04-12	Pasador de chaveta de 1/8 x 3/4	227	817 49 05-12	Tornillo 5/16-18 x 3/4
160	532 16 94-84	Abrazadera de retención	230	532 18 89-67	Tuerca
161	532 10 57-09	Resorte de retorno del embrague	284	532 41 76-93	Tuerca 1/4-20
163	532 44 82-75	Control del pedal de la barra	307	874 18 04-12	Tornillo 1/4-20 x 3/4
166	532 42 91-64	Tuerca			
167	532 40 52-57	Pestillo del freno de mano			
170	532 19 43-22	Sujetador de la correa central			
171	872 11 06-16	Perno 3/8-16 unc			
183	532 13 70-57	Separador			
184	532 44 14-55	Manija del freno de mano			

**NOTA:** Las dimensiones de todos los componentes están expresadas en pulgadas americanas. 1 pulgada = 25,4 mm

TRACTOR MODELO NO. YT46LS (96043016701), PRODUCTO NO. 960 43 01-67  
MOTOR

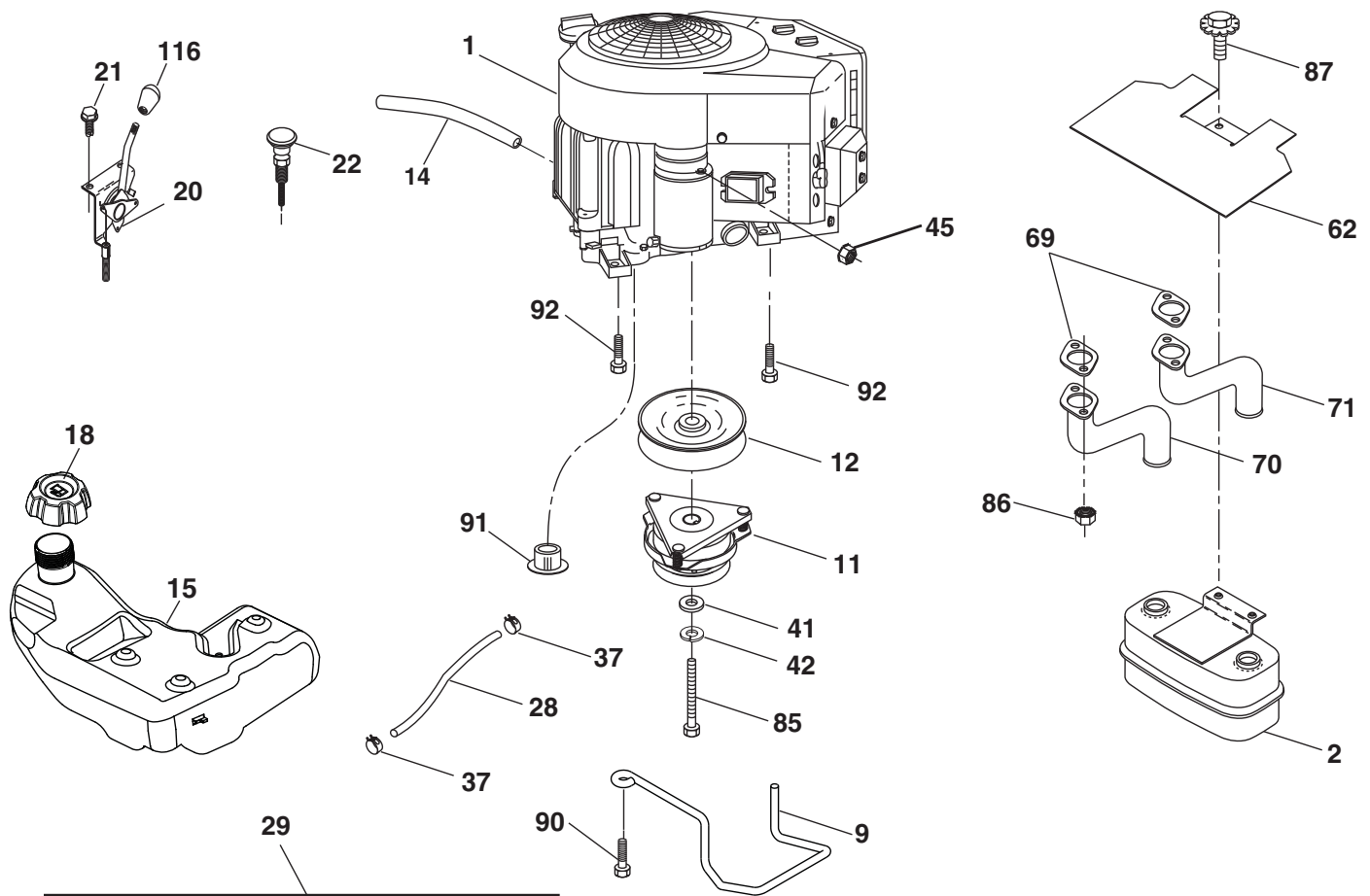

engine-tex\_Kawa-2cyl\_27

**TRACTOR MODELO NO. YT46LS (96043016701), PRODUCTO NO. 960 43 01-67  
MOTOR**

<b>CÓDIGO NO.</b>	<b>PIEZA NO.</b>	<b>DESCRIPCIÓN</b>
1	— — — — —	Motor Kawa modelo No. FR651-AS28 (581411101) (Haga el pedido de las piezas al fabricante del motor.)
2	532 44 59-62	Silenciador
9	584 90 80-01	Ensamble del sujetador de la correa del motor
11	532 40 00-08	Embrague de eléctrico
12	532 40 50-97	Polea del motor
14	532 14 84-56	Tubo de fácil drenaje de aceite
15	532 43 80-80	Tanque de Gasolina de 4,0R
18	532 43 92-08	Tapa
20	532 42 43-41	Control del regulador
21	532 41 63-58	Tornillo No. 10 x 0,75 con rosca reforzada
22	532 18 95-41	Control de la estrangulación del motor
28	532 40 11-35	Línea de combustible
29	532 13 71-80	Equipo apagachispas
37	532 12 34-87	Abrazadera de la manguera
41	532 12 61-97	Arandela 1-1/2 x 15/32 x .250
42	810 04 07-00	Arandela de presión de 7/16
45	873 51 04-00	Tuerca
62	532 43 40-17	Silenciador con pantalla térmica
69	532 17 81-51	Junta
70	583 95 56-01	Tubo de escape izquierdo
71	583 95 57-01	Tubo de escape derecho
85	532 17 39-37	Perno de 7/16-20 x 3.75 grado 5
86	532 18 43-62	Tuerca M8-1.25
87	537 17 18-77	Perno de 5/16-18 unc x 1
90	817 00 06-16	Tornillo de 3/8-16 x 1
91	532 18 74-95	Buje
92	817 12 06-16	Tornillo 3/8-16 x 1
116	539 13 26-24	Tacto suave de la perilla

**NOTA:** Las dimensiones de todos los componentes están expresadas en pulgadas americanas. 1 pulgada = 25,4 mm  
Para las piezas del servicio y de recambio del motor, llame el número gratis para su fabricante del motor enumerado abajo:  
Kawasaki 1-949-460-5688

TRACTOR MODELO NO. YT46LS (96043016701), PRODUCTO NO. 960 43 01-67  
ENSAMBLE DE LA DIRECCIÓN

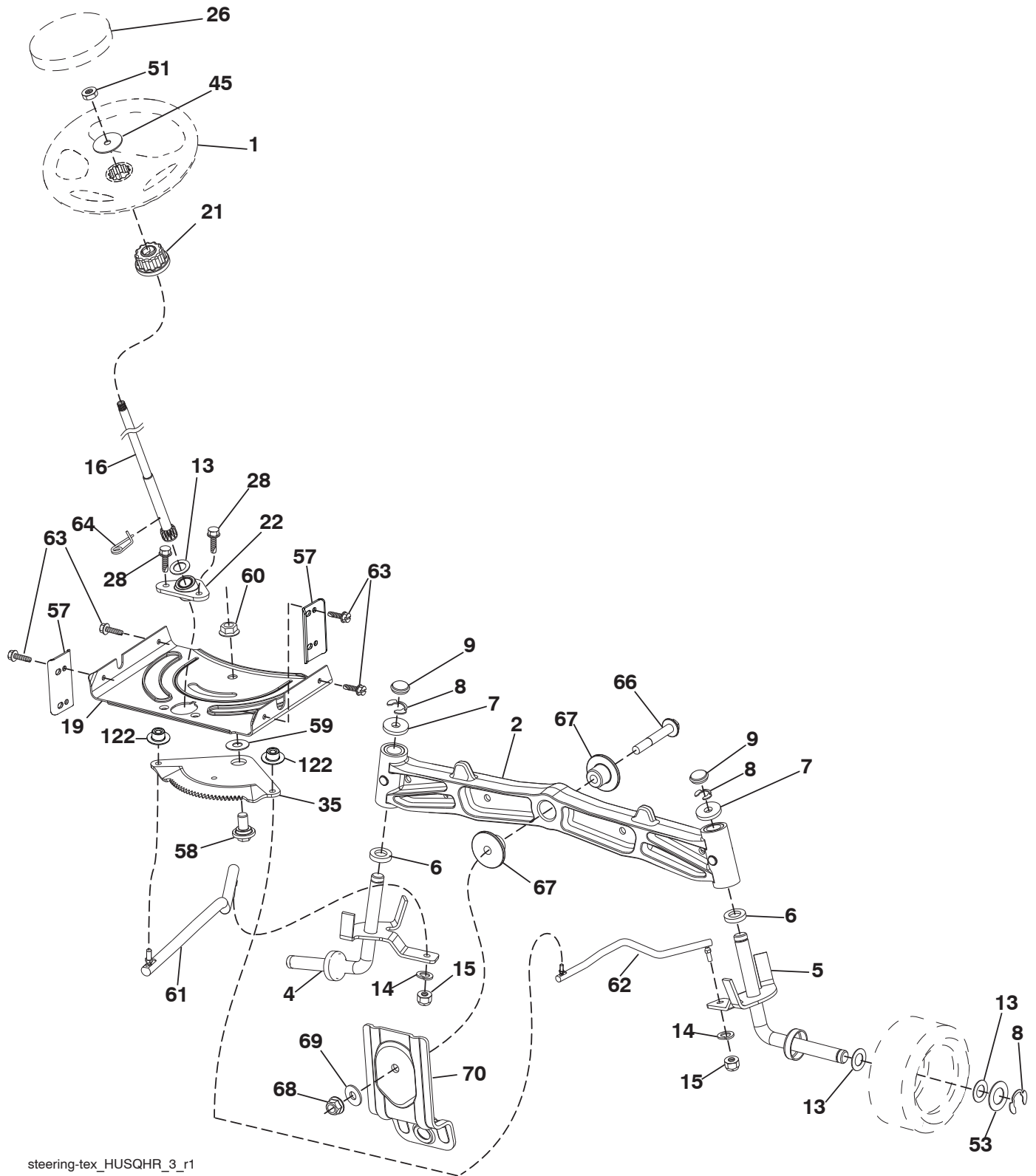

steering-tex\_HUSQHR\_3\_r1

**TRACTOR MODELO NO. YT46LS (96043016701), PRODUCTO NO. 960 43 01-67**  
**ENSAMBLE DE LA DIRECCIÓN**

<b>CÓDIGO NO.</b>	<b>PIEZA NO.</b>	<b>DESCRIPCIÓN</b>
1	532 43 97 40	Volante de dirección
2	532 19 59-68	Ensamble del eje delantero
4	532 40 30-87	Ensamble del husillo izquierdo
5	532 40 30-88	Ensamble del husillo derecho
6	532 12 49-31	Pista del rodamiento para reforzar el impulso
7	532 12 17-48	Arandela de 25/32 x 1-5/8 calibre 16
8	812 00 00-29	Abrazadera del aro No. T5304-75
9	532 12 12-32	Tapa del husillo
13	532 12 17-49	Arandela de 25/32 x 1-1/4 calibre 16
14	810 04 06-00	Arandela de presión de 3/8
15	873 54 06-00	Tuerca corona de presión de 3/8-24 unf
16	532 40 82-19	Eje de dirección
19	532 19 47-29	Placa de dirección
21	532 18 67-37	Adaptador del volante de dirección
22	532 42 05-37	Soporte del inferior
26	532 43 97-43	Inserto del volante de dirección
28	817 00 06-12	Tornillo de 3/8-16 x 3/4
35	532 19 47-32	Engranaje del sector de la placa
45	819 18 38-12	Arandela de 9/16 ID x 2-3/8 OD 12 GZIN
51	873 94 08-00	Contratuerca hexagonal de seguridad de 1/2-20 unf
53	532 18 89-67	Arandela reforzada de .793 x 1.637 x .060
57	532 40 74-65	Tope superior del soporte
58	532 19 47-47	Perno de tope del sector del pivote CFM
59	532 19 47-48	Arandela de empuje del sector de dirección
60	873 97 10-00	Tuerca de presión con brida de 5/8-11
61	532 19 47-40	Barra de acoplamiento izquierda
62	532 19 47-41	Barra de acoplamiento derecha
63	817 00 05-12	Tornillo de 5/16-18 x 3/4
64	532 19 98-49	Abrazadera de retención del resorte de la dirección
66	871 02 07-48	Perno de cabeza hexagonal con brida acanalada de 7/16-14 x 3
67	532 19 47-37	Buje PM del eje delantero
68	873 90 07-00	Tuerca de presión con brida de 7/16-14 grado 5
69	532 19 91-62	Arandela de 1.5 x .505 x .118
70	532 19 61-97	Soporte de la plataforma delantera
122	532 44 49-62	Tapa

**NOTA:** Las dimensiones de todos los componentes están expresadas en pulgadas americanas. 1 pulgada = 25,4 mm

**TRACTOR MODELO NO. YT46LS (96043016701), PRODUCTO NO. 960 43 01-67**  
**PLATAFORMA DE LA CORTADORA DE CÉSPED**

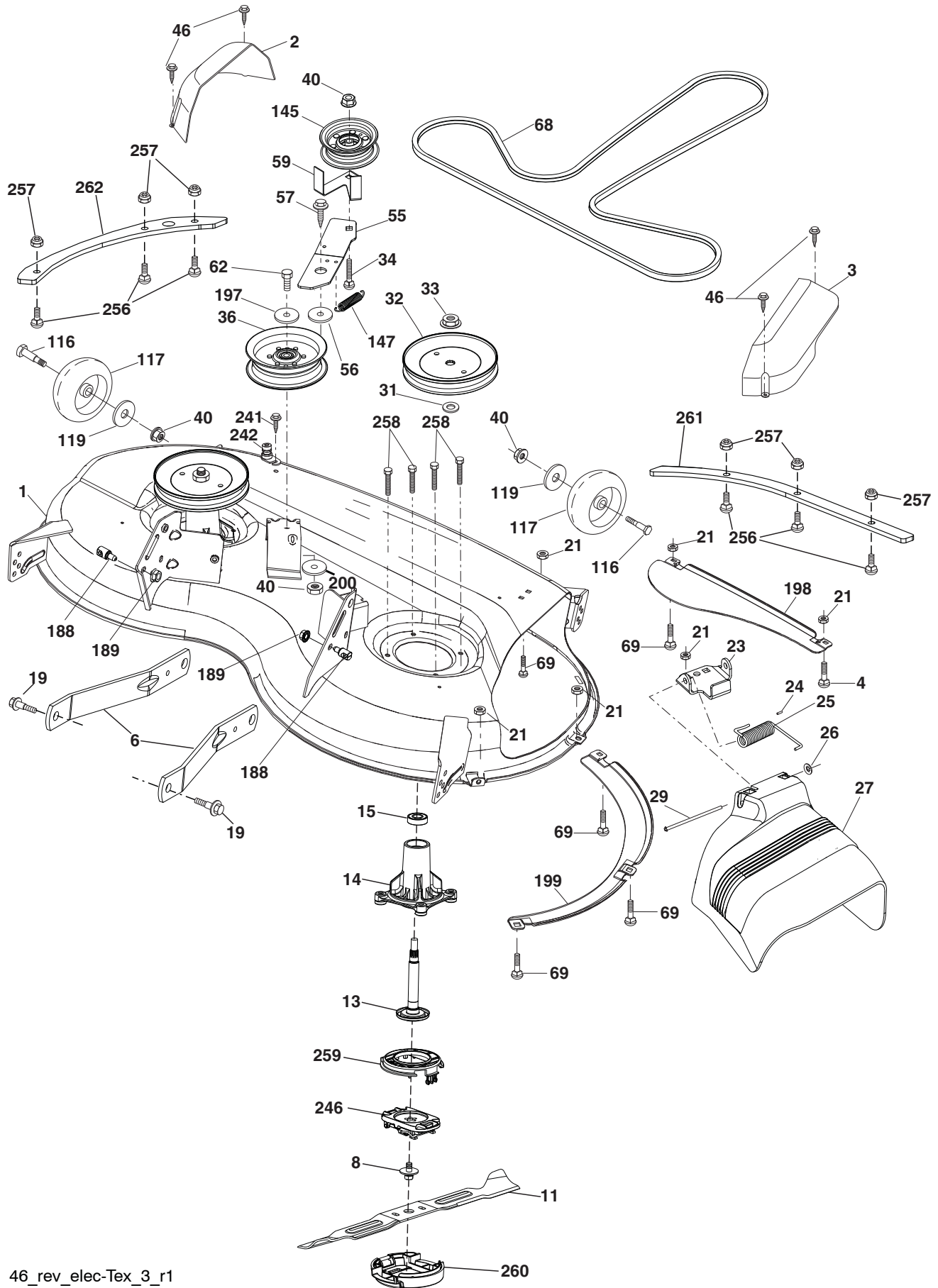

46\_rev\_elec-Tex\_3\_r1

**TRACTOR MODELO NO. YT46LS (96043016701), PRODUCTO NO. 960 43 01-67  
PLATAFORMA DE LA CORTADORA DE CÉSPED**

CÓDIGO PIEZA			CÓDIGO PIEZA		
NO.	NO.	DESCRIPCIÓN	NO.	NO.	DESCRIPCIÓN
1	583 90 09-02	Carcasa de la cortadora de césped	117	532 17 48-73	Calibrador de la rueda
2	532 40 55-07	Cubierta izquierda del mandril	119	819 13 20-12	Arandela 13/32 x 1-1/2 x calibre 11
3	532 40 55-06	Cubierta derecha del mandril	145	532 19 31-97	Polea loca
4	874 76 05-12	Perno 5/16-18 unc	147	532 19 72-51	Retorno del resorte
6	532 19 51-86	Brazo de la suspensión	188	532 19 51-61	Sujetador del travesaño
8	584 30 93-01	Tornillo	189	873 90 05-00	Tuerca
11	581 04 39-01	Cuchilla de la cortadora de césped	197	819 13 13-12	Arandela 13/32 x 13/16 x calibre 12
13	580 85 47-01	Ensamble del eje de alto	198	532 40 31-49	Deflector delantero central
14	580 79 61-01	Carcasa del mandril	199	532 40 31-50	Deflector delantero derecho
15	532 11 04-85	Rodamiento de bolas del mandril	200	532 41 35-24	Arandela 13/32 x 1 x 1/2 11
19	532 19 65-39	Perno	241	532 15 29-27	Tornillo
21	873 68 05-00	Tuerca	242	532 41 55-98	Puerto De Lavado De La Cubierta
23	532 19 25-57	Soporte del deflector	246	580 95 40-02	Cuchilla soporte
24	532 10 53-04	Tapa de la manga	256	578 29 64-04	Tornillo 5/16-18
25	532 19 70-26	Resorte de torsión del deflector	257	873 90 04-00	Tuerca 1/4-20 unc
26	532 11 04-52	Tuerca	258	584 95 39-01	Perno 3/8-18 x1.19
27	532 40 53-57	Protector del deflector	259	584 30 66-01	Tapa del superior
29	532 13 14-91	Varilla de la bisagra	260	584 30 67-01	Tapa del inferior
31	532 18 76-90	Arandela	261	581 96 77-05	Placa de refuerzo frente
32	532 19 74-73	Polea del mandril	262	581 96 78-05	Placa de refuerzo lado
33	532 40 02-34	Tuerca	--	532 41 64-05	Accesorio del conexión
34	872 11 06-12	Perno 3/8-16 x 1-1/2 Gr. 5	--	580 85 60-01	Ensamble del Mandril-alto (solo incluye la carcasa (Código #14), el ensamble del eje (Código #13) y el rodamiento (Código #15); no incluye la polea/tuerca/arandela ni los pernos/arandelas de la cuchilla)
36	532 19 73-79	Polea loca			
40	873 90 06-00	Tuerca 3/8-16 unc			
46	532 13 77-29	Tornillo			
55	532 19 72-49	Brazo de la polea			
56	532 19 90-92	Espaciador de retención			
57	817 00 06-16	Tornillo 3/8-16 x 1	--	581 74 54-01	Reemplazo de la cortadora de césped, completa
59	532 14 10-43	Dispositivo de protección de la polea (94)			
62	874 52 06-36	Perno 3/8-16 unc x 2-1/4 Gr. 5			
68	532 40 51-43	Correa trapezoidal			
69	872 14 05-05	Perno			
116	532 19 34-06	Perno			

**NOTA:** Las dimensiones de todos los componentes están expresadas en pulgadas americanas. 1 pulgada = 25,4 mm

**TRACTOR MODELO NO. YT46LS (96043016701), PRODUCTO NO. 960 43 01-67  
ELEVACIÓN DE LA CORTADORA DE CÉSPED**

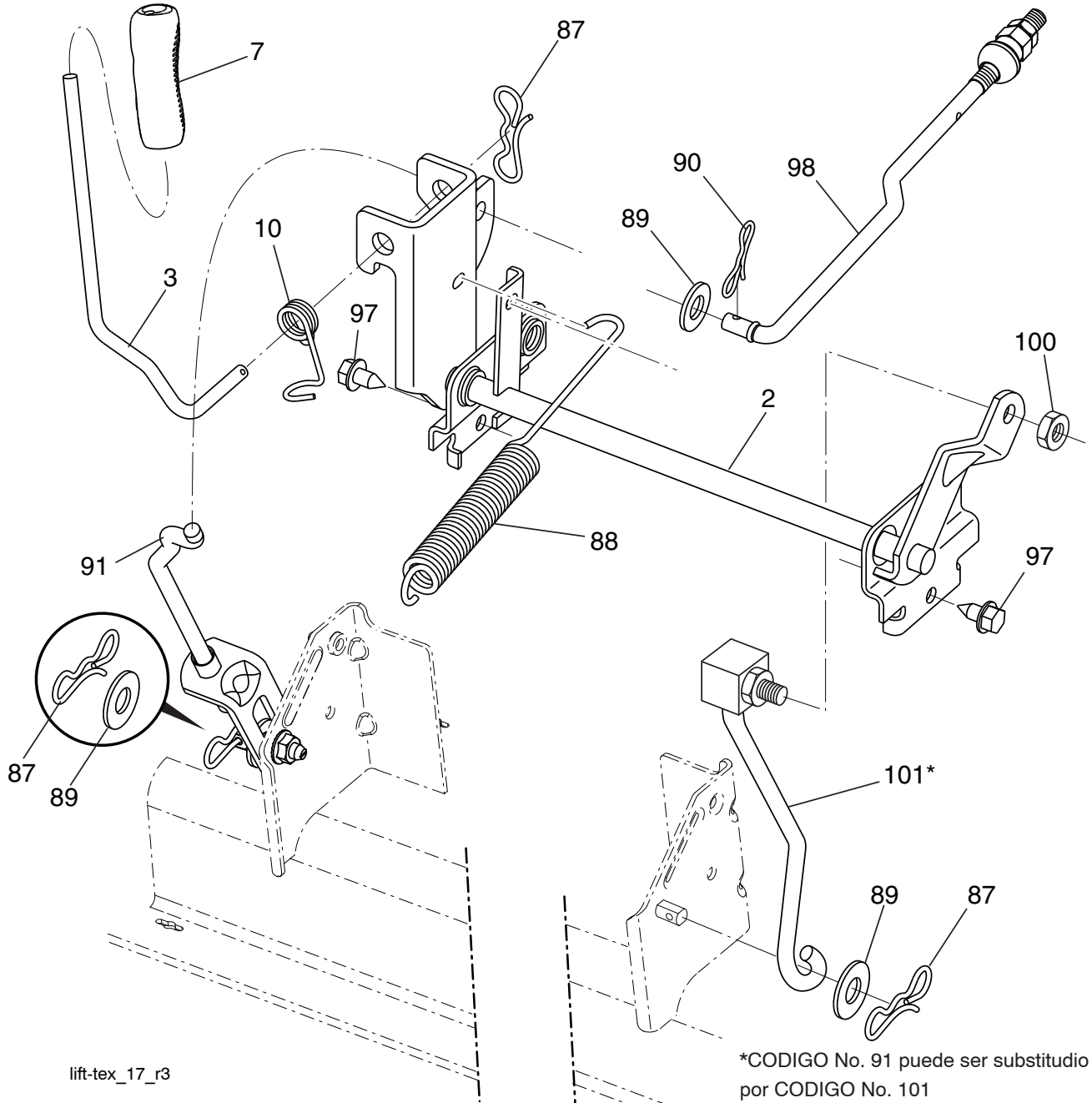

lift-tex\_17\_r3

CÓDIGO NO.	PIEZA NO.	DESCRIPCIÓN
2	532 42 20-27	Ensamble del eje de la elevación
3	532 19 52-31	Ensamble de la palanca de elevación derecha
7	580 96 23-01	Mango de la palanca
10	532 19 63-14	Resorte de torsión
87	532 19 42-09	Pasador de chaveta de 7/16 con bloqueo en forma de mariposa
88	532 41 07-10	Resorte de ayuda de la elevación
89	819 19 19-12	Arandela de zinc transparente
90	532 19 42-08	Pasador de chaveta de 5/16 con bloqueo en forma de mariposa
91	532 19 51-81	Ensamble del acoplamiento Elevación trasera

CÓDIGO NO.	PIEZA NO.	DESCRIPCIÓN
97	817 00 06-12	Tornillo de 3/8-16 x 3/4
98	532 19 52-70	Acoplamiento frontal de la elevación de la cortadora de césped
100	873 93 06-00	Tuerca de presión central de 3/8-16 unc
101	532 40 70-03	Ensamble del acoplamiento Elevación fijo

**NOTA:** Las dimensiones de todos los componentes están expresadas en pulgadas americanas. 1 pulgada = 25,4 mm



**TRACTOR MODELO NO. YT46LS (96043016701), PRODUCTO NO. 960 43 01-67  
ENSAMBLE DEL ASIENTO**

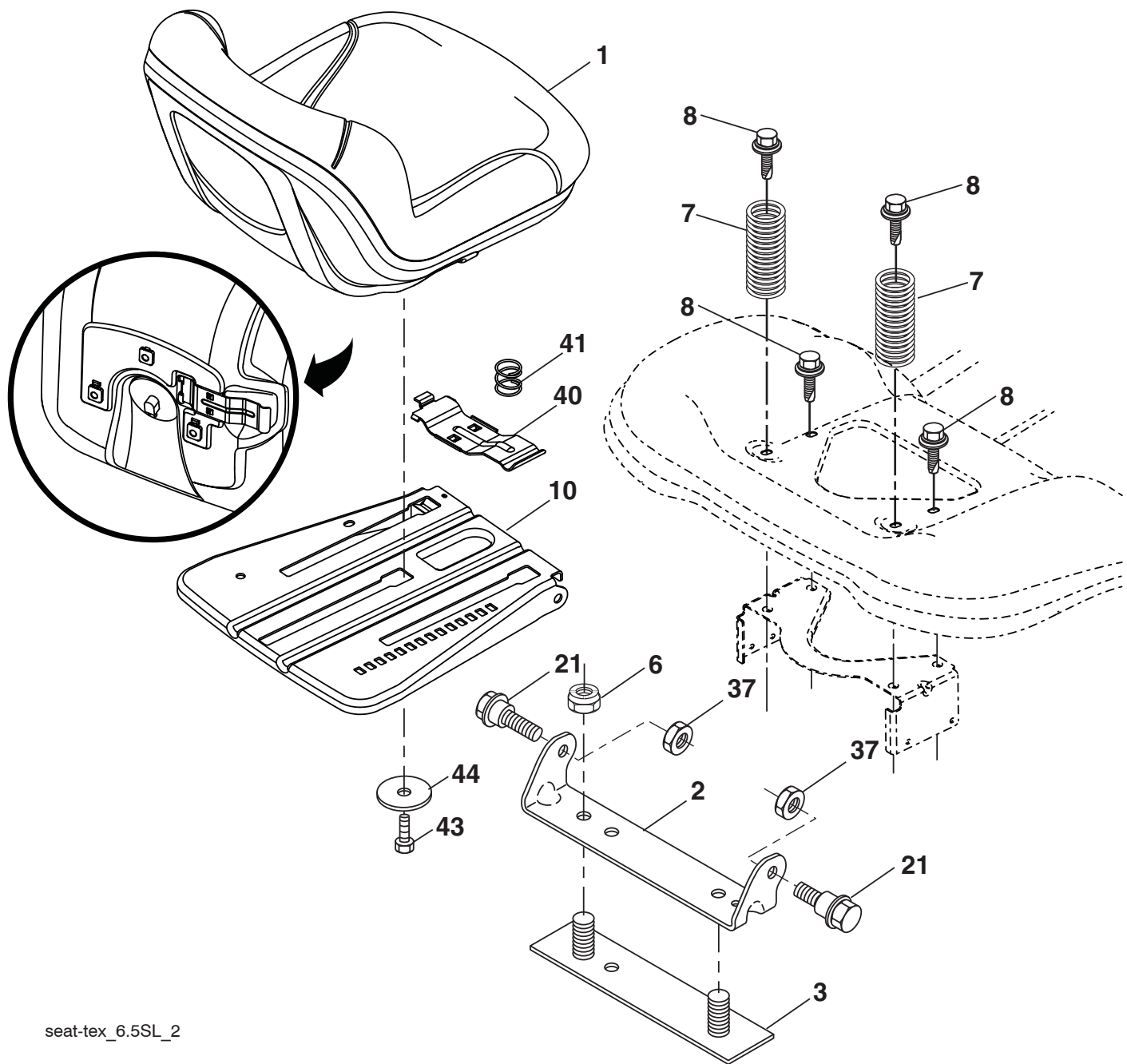

seat-tex\_6.5SL\_2

CÓDIGO NO.	PIEZA NO.	DESCRIPCIÓN	CÓDIGO NO.	PIEZA NO.	DESCRIPCIÓN
1	532 43 98-22	Asiento	40	532 43 98-71	Manija para deslizar el asiento
2	532 18 01-66	Soporte pivotante del guardabarros	41	532 19 82-00	Resorte para trabar el asiento
3	532 14 06-75	Conector del ensamble del guardabarros	43	874 76 06-12	Perno de cabeza hexagonal con aleta de 3/8-16 unc x 3/4
6	873 80 06-00	Tuerca de presión c/aislamiento de 3/8-16 unc	44	819 13 38-12	Arandela de 13/32 x 2-3/8 calibre 12
7	532 12 41-81	Resorte del asiento			
8	532 17 18-77	Perno de 5/16" unc x 3/4"			
10	532 19 69-77	Bandeja del asiento			
21	532 17 18-52	Perno de 5/16-18			
37	873 80 05-00	Perno de tope de 5/16-18 unc			

**NOTA:** Las dimensiones de todos los componentes están expresadas en pulgadas americanas. 1 pulgada = 25,4 mm

# TRACTOR MODELO NO. YT46LS (96043016701), PRODUCTO NO. 960 43 01-67

## CALCOMANÍAS

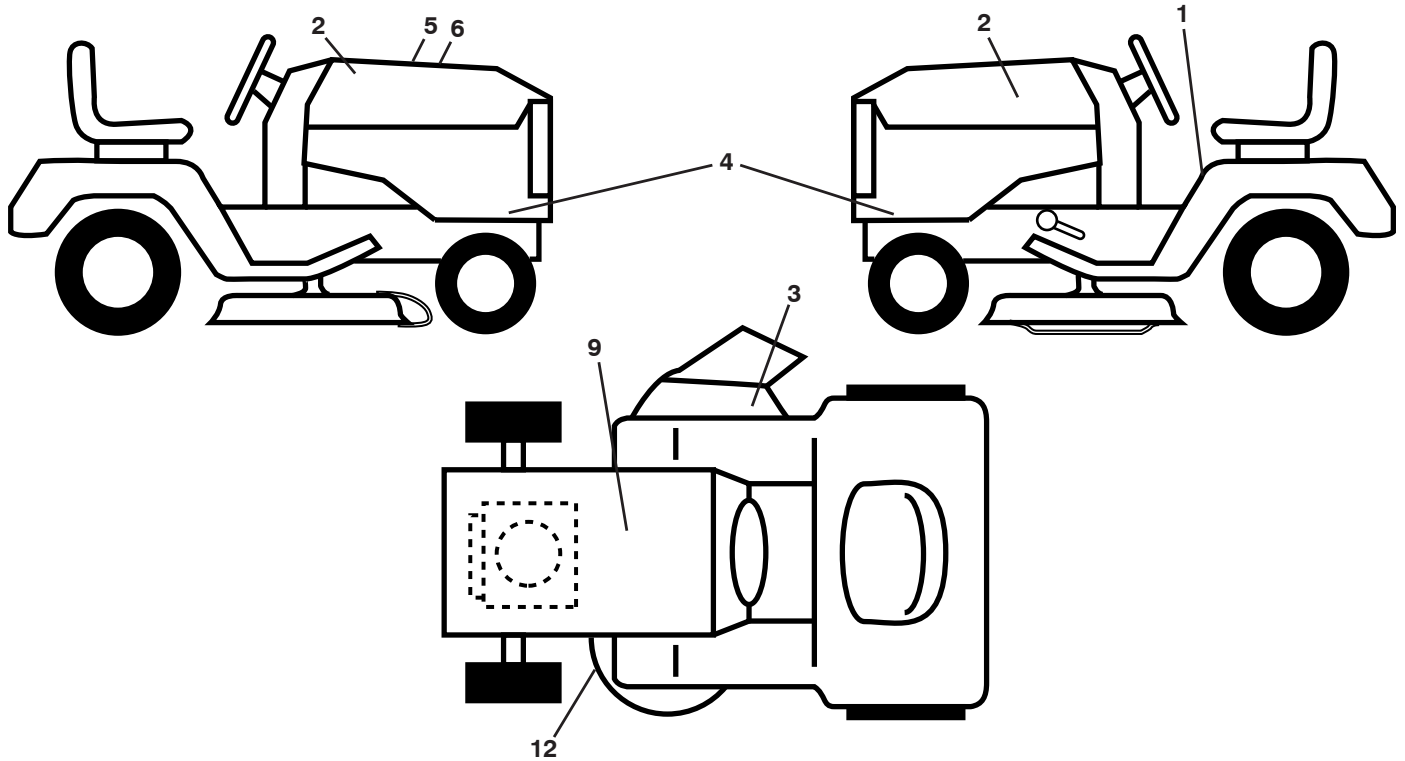

### CÓDIGO PIEZA NO. NO.

### DESCRIPCIÓN

1	581 57 89-01	Calcomanía, Advertencia
2	581 62 73-01	Calcomanía para el insignia
3	581 57 95-01	Calcomanía, Advertencia
4	581 61 97-01	Calcomanía para el panel lateral
5	532 42 38-29	Calcomanía del cliente
6	584 47 37-01	Calcomanía de reemplazo
9	532 14 50-05	Calcomanía de Peligro/Punto de interconexión
12	581 58 00-01	Calcomanía del diagrama de la cortadora de césped

### CÓDIGO PIEZA NO. NO.

### DESCRIPCIÓN

--	581 72 48-01	Calcomanía para la desviación
--	532 43 96-81	Forro del apoyo para los pies (LD)
--	532 43 96-82	Forro del apoyo para los pies (LI)
--	585 71 44-01	Calcomanía Armor cubierta protegida
--	586 00 01-96	Manual del operario (Inglês/Espanhol)
--	586 00 01-27	Manual del repuestos (Inglês/Espanhol)

## WHEELS AND TIRES

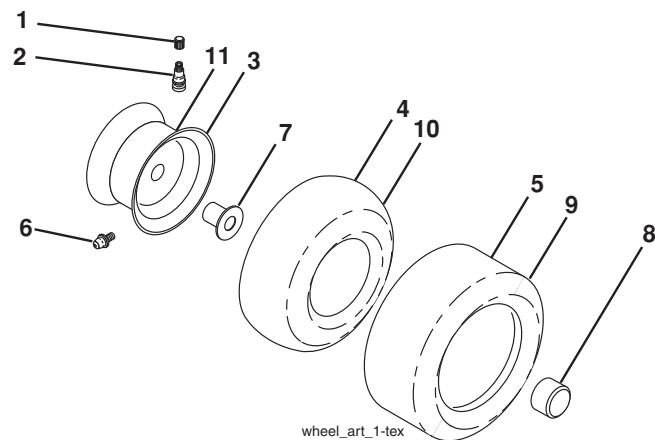

### CÓDIGO PIEZA NO. NO.

### DESCRIPCIÓN

1	532 05 91-92	Tapa de la válvula del neumático
2	532 06 51-39	Vástago de la válvula
3	532 13 83-36	Ensamble de las llantas delanteras
4	532 05 99-04	Cámara delantera
5	532 10 62-22	Neumático delantero 15 x 6-6
6	532 12 49-57	Accesorio para engrasar (solo para la rueda delantera)
7	532 12 49-59	Rodamiento de la brida (solo para la rueda delantera)
8	532 17 50-39	Tapa del eje (solo para la rueda delantera)
9	532 13 84-68	Neumático trasero 20 x 8-8
10	532 12 49-26	Cámaratrasera (Mantenimientosólo)
11	532 13 83-37	Ensamble trasero de la llanta
--	532 14 43-34	Sellador para neumáticos (tubo de 10 onzas [283 gr])

**NOTE:** All component dimensions given in U.S. inches  
1 inch = 25.4 mm

---

# NOTES/AVISO

---

**11/01/2013 CL**