

**ILLUSTRATED PARTS LIST**

**MODEL NUMBER ST 261E**

**PRODUCT NUMBER 961 91 00-30**

**MFG. ID. NUMBER 96191003009**

# REPAIR PARTS

# AUGER HOUSING / IMPELLER ASSEMBLY

SNOW THROWER - MODEL NO. **ST 261E** (96191003009), PRODUCT NO. 961 91 00-30

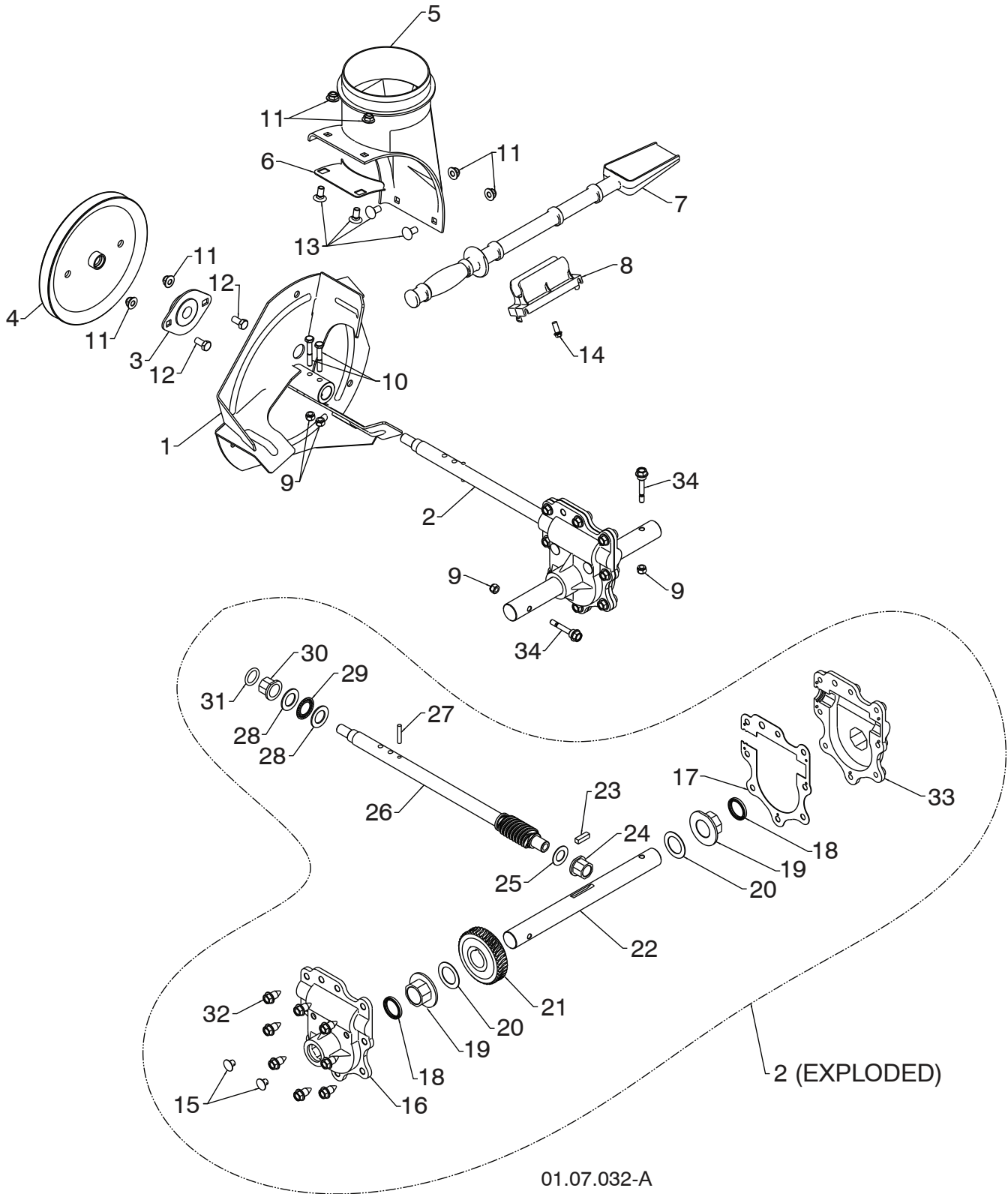

**NOTE:** All component dimensions given in U.S. inches. 1 inch = 25.4 mm  
**IMPORTANT:** Use only Original Equipment Manufacturer (O.E.M.) replacement parts.  
Failure to do so could be hazardous, damage your snow thrower and void your warranty.

**REPAIR PARTS****AUGER HOUSING / IMPELLER ASSEMBLY****SNOW THROWER - MODEL NO. ST 261E (96191003009), PRODUCT NO. 961 91 00-30**

<b>KEY NO.</b>	<b>PART NO.</b>	<b>DESCRIPTION</b>
1	532 18 41-05	IMPELLER
2	584 64 83-01	GEARBOX ASSEMBLY
3	532 18 89-09	BEARING
4	585 09 32-01	IMPELLER PULLEY
5	585 05 69-01	DISCHARGE BASE
6	532 18 40-95	CORNER BRACKET
7	532 19 21-99	CLEAN OUT TOOL
8	532 40 54-00	TOOL CLIP
9	873 80 04-00	NUT 1/4-20
10	874 78 04-26	SCREW 1/4-20 X .625
11	532 42 79-42	NUT 5/16-18
12	532 16 31-83	SCREW 5/16-18 X .625
13	532 18 03-55	CARRIAGE BOLT
14	532 19 41-89	SCREW 13-16 X .625
15	532 40 77-60	PLUG
16	532 42 73-02	GEARBOX COVER RH
17	532 42 73-45	GASKET
18	532 40 77-70	SEAL
19	532 40 77-62	BEARING
20	532 17 46-97	THRUST WASHER 1.00
21	580 36 41-01	WORM GEAR
22	532 40 77-64	AUGER SHAFT
23	532 18 92-82	SQUARE KEY
24	532 40 77-58	BEARING
25	532 17 46-83	THRUST WASHER
26	584 64 84-01	IMPELLER SHAFT
27	532 18 42-05	ROLL PIN
28	532 17 46-81	THRUST WASHER
29	532 17 46-84	THRUST BEARING
30	532 40 77-69	BEARING
31	532 40 77-68	O-RING
32	532 40 77-67	SCREW 5/16-18 X .750
33	532 42 73-17	GEARBOX COVER LH
34	532 19 20-90	SHEAR BOLT

**NOTE:** All component dimensions given in U.S. inches. 1 inch = 25.4 mm

**IMPORTANT:** Use only Original Equipment Manufacturer (O.E.M.) replacement parts.  
Failure to do so could be hazardous, damage your snow thrower and void your warranty.

# REPAIR PARTS

# AUGER HOUSING / IMPELLER ASSEMBLY

SNOW THROWER - MODEL NO. **ST 261E** (96191003009), PRODUCT NO. 961 91 00-30

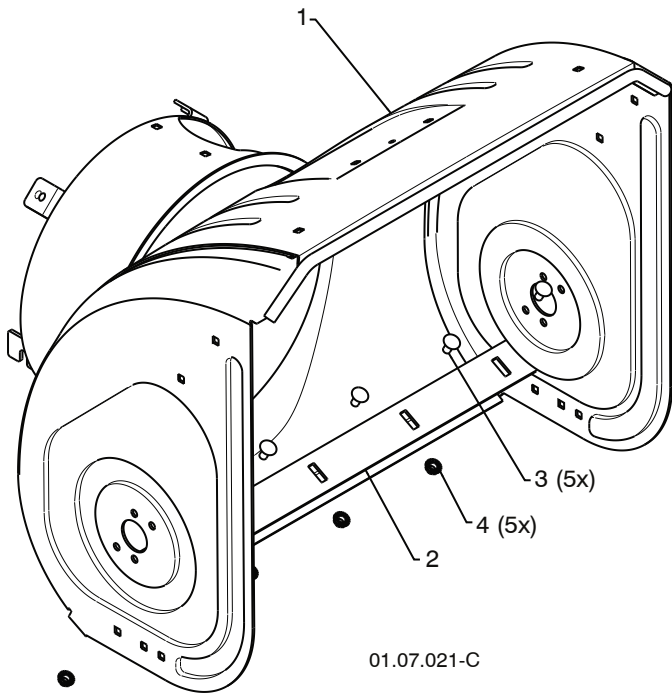

01.07.021-C

KEY NO.	PART NO.	DESCRIPTION
1	532 42 93-45	AUGER HOUSING
2	532 40 78-25	SCRAPER BAR
3	872 27 05-05	CARRIAGE BOLT 5/16-18 X .625
4	532 15 53-77	NUT 5/16-18

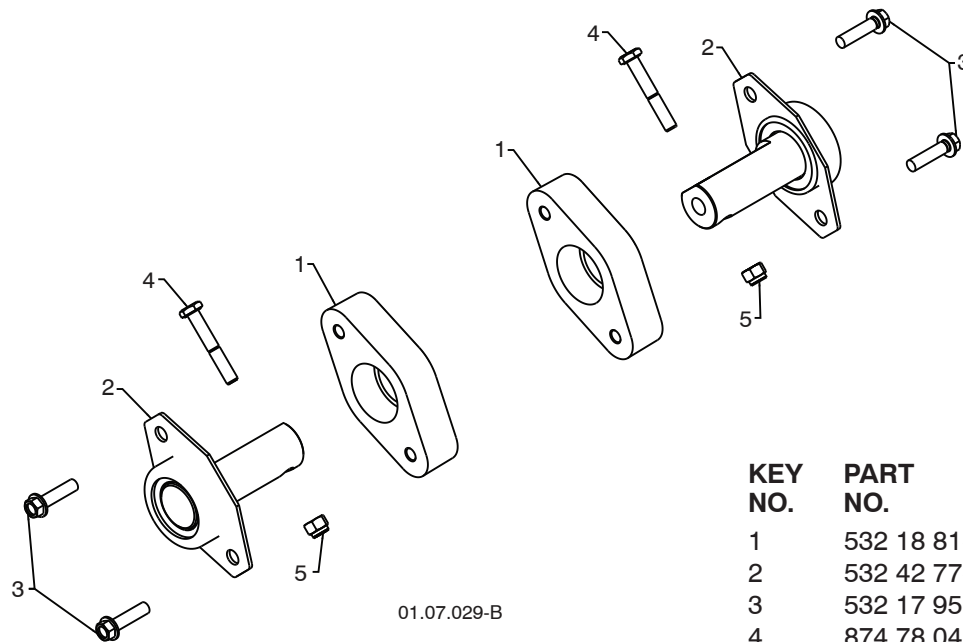

01.07.029-B

KEY NO.	PART NO.	DESCRIPTION
1	532 18 81-70	PLASTIC RETAINER
2	532 42 77-62	AUGER BALL BEARING
3	532 17 95-82	SCREW 5/16-18 X 1.00
4	874 78 04-26	SCREW 1/4-20 X .625
5	873 80 04-00	NUT 1/4-20

**NOTE:** All component dimensions given in U.S. inches. 1 inch = 25.4 mm  
**IMPORTANT:** Use only Original Equipment Manufacturer (O.E.M.) replacement parts.  
 Failure to do so could be hazardous, damage your snow thrower and void your warranty.

# REPAIR PARTS

# AUGER HOUSING / IMPELLER ASSEMBLY

SNOW THROWER - MODEL NO. **ST 261E** (96191003009), PRODUCT NO. 961 91 00-30

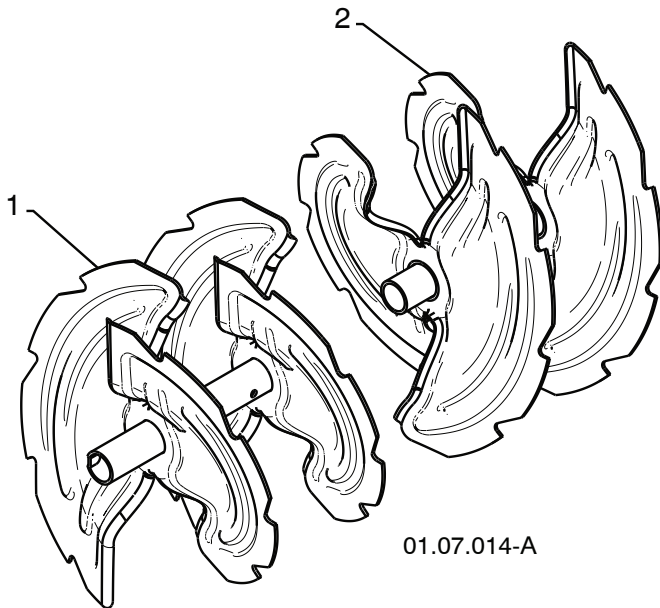

KEY NO.	PART NO.	DESCRIPTION
1	532 42 21-03	AUGER ASSEMBLY 24 LH
2	532 42 21-04	AUGER ASSEMBLY 24 RH

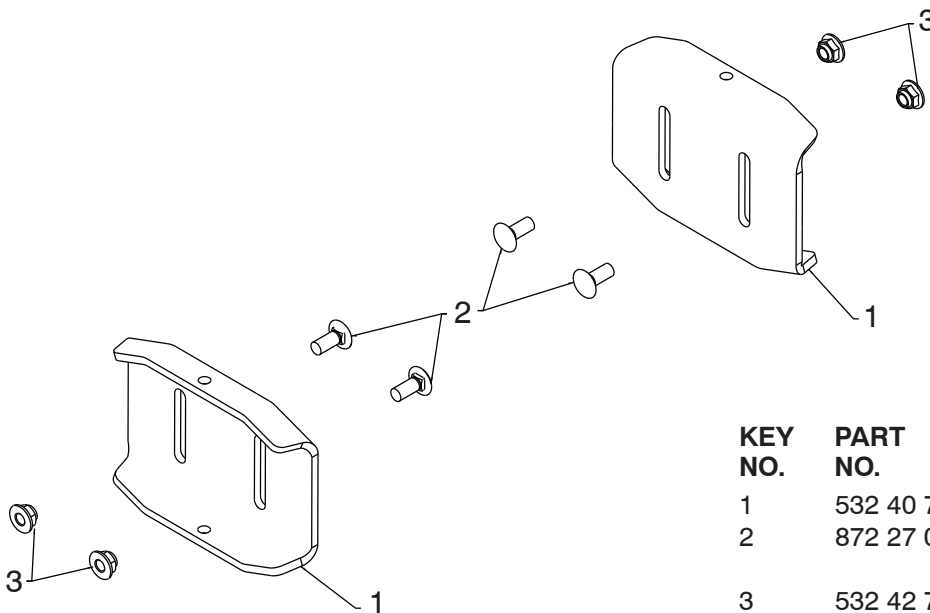

KEY NO.	PART NO.	DESCRIPTION
1	532 40 78-34	SKID PLATE
2	872 27 05-06	CARRIAGE BOLT 5/16-18 X .750
3	532 42 79-42	NUT 5/16-18

01.11.002-C

**NOTE:** All component dimensions given in U.S. inches. 1 inch = 25.4 mm  
**IMPORTANT:** Use only Original Equipment Manufacturer (O.E.M.) replacement parts. Failure to do so could be hazardous, damage your snow thrower and void your warranty.

# REPAIR PARTS

# AUGER HOUSING / IMPELLER ASSEMBLY

SNOW THROWER - MODEL NO. **ST 261E** (96191003009), PRODUCT NO. 961 91 00-30

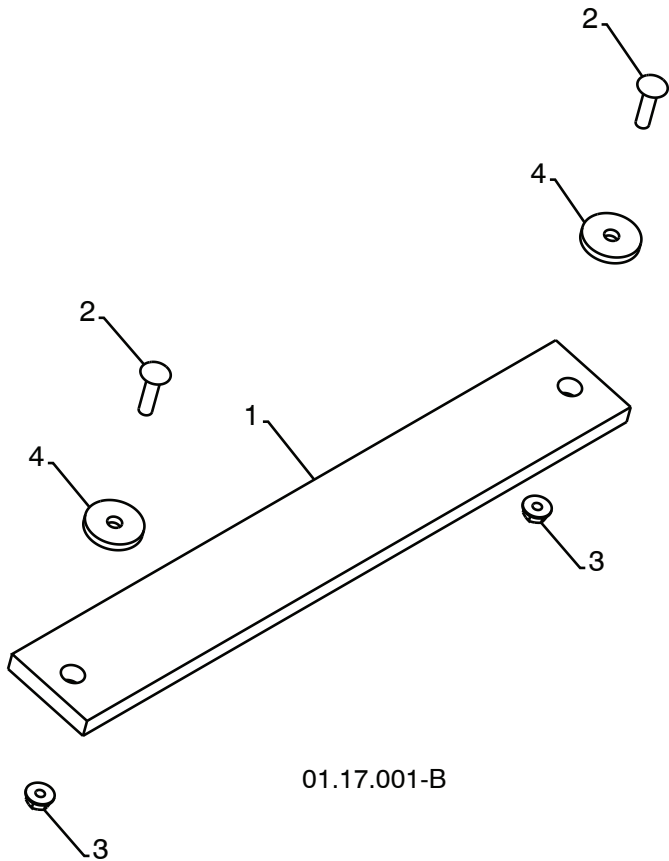

KEY NO.	PART NO.	DESCRIPTION
1	532 18 25-13	WEIGHT BAR
2	872 11 05-10	CARRIAGE BOLT 5/16-18 X 1.25
3	532 75 11-53	NUT 5/16-18
4	819 11 22-06	WASHER

01.17.001-B

**NOTE:** All component dimensions given in U.S. inches. 1 inch = 25.4 mm  
**IMPORTANT:** Use only Original Equipment Manufacturer (O.E.M.) replacement parts.  
Failure to do so could be hazardous, damage your snow thrower and void your warranty.

# REPAIR PARTS

# CONTROL PANEL / DISCHARGE CHUTE

SNOW THROWER - MODEL NO. **ST 261E** (96191003009), PRODUCT NO. 961 91 00-30

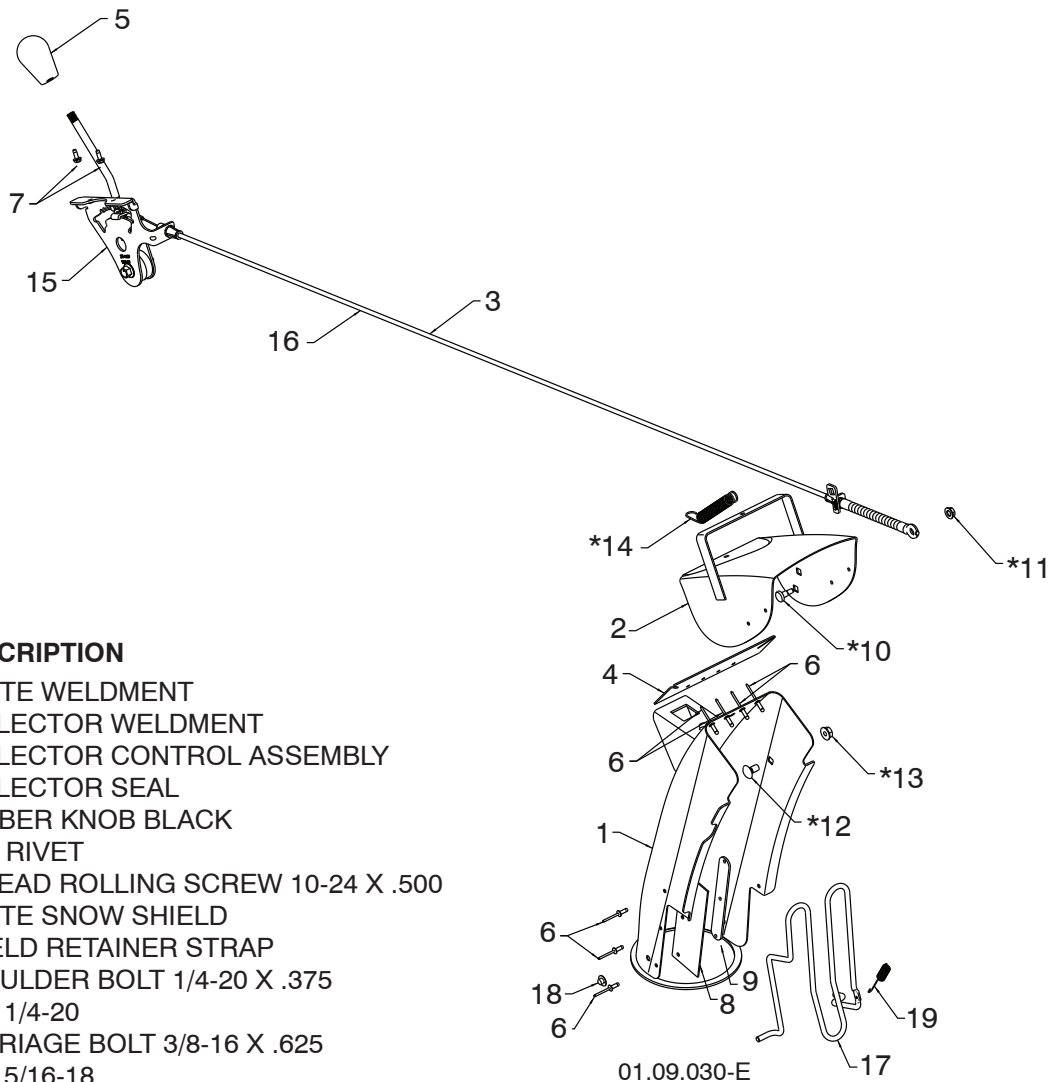

KEY NO.	PART NO.	DESCRIPTION
1	532 44 40-41	CHUTE WELDMENT
2	532 18 41-13	DEFLECTOR WELDMENT
3	587 03 08-01	DEFLECTOR CONTROL ASSEMBLY
4	532 42 03-25	DEFLECTOR SEAL
5	580 67 32-01	RUBBER KNOB BLACK
6	532 12 84-15	POP RIVET
7	817 54 10-08	THREAD ROLLING SCREW 10-24 X .500
8	532 43 03-24	CHUTE SNOW SHIELD
9	532 42 17-28	SHIELD RETAINER STRAP
*10	532 17 98-29	SHOULDER BOLT 1/4-20 X .375
*11	532 19 17-30	NUT 1/4-20
*12	872 25 05-05	CARRIAGE BOLT 3/8-16 X .625
*13	532 75 11-53	NUT 5/16-18
*14	532 18 45-05	DEFLECTOR SPRING
15	532 42 06-79	(SERVICE PART) DEFLECTOR CONTROL
16	587 03 09-01	(SERVICE PART) DEFLECTOR CABLE BLACK
17	532 43 55-82	CHUTE GUARD
18	532 05 93-49	PUSH NUT
19	532 43 56-16	SPRING

### NOTE:

1. ALL ITEMS INDICATED WITH AN \* ARE PROVIDED IN THE BAG OF ITEMS SHIPPED LOOSE WITH PRODUCT.
2. ITEMS 15 AND 16 ARE SERVICE PART NUMBERS TO ALLOW PURCHASE OF INDIVIDUAL ITEMS IF NECESSARY.

**NOTE:** All component dimensions given in U.S. inches. 1 inch = 25.4 mm  
**IMPORTANT:** Use only Original Equipment Manufacturer (O.E.M.) replacement parts.  
 Failure to do so could be hazardous, damage your snow thrower and void your warranty.

# REPAIR PARTS

# CONTROL PANEL / DISCHARGE CHUTE

SNOW THROWER - MODEL NO. **ST 261E** (96191003009), PRODUCT NO. 961 91 00-30

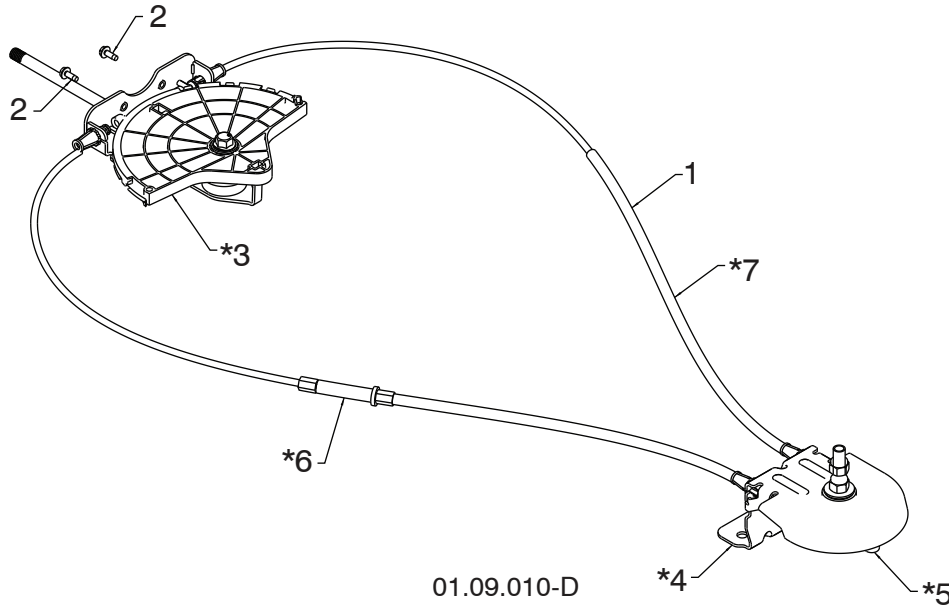

KEY NO.	PART NO.	DESCRIPTION
1	532 42 82-72	LEVER/CABLE ROTATOR ASSEMBLY
2	817 54 10-08	THREAD ROLLING SCREW 10-24 X .500
*3	532 42 06-78	ROTATOR HEAD
*4	585 19 92-01	ROTATOR PIVOT BRACKET
*5	532 42 06-75	PULLEY PIVOT
*6	532 42 82-73	CABLE ASSEMBLY ADJUSTABLE
*7	532 42 83-10	CABLE ASSEMBLY HEAT SHIELD

### NOTES:

1. ITEMS INDICATED WITH AN \* ARE LISTED AS REFERENCE FOR SERVICE PARTS ONLY.

**NOTE:** All component dimensions given in U.S. inches. 1 inch = 25.4 mm  
**IMPORTANT:** Use only Original Equipment Manufacturer (O.E.M.) replacement parts. Failure to do so could be hazardous, damage your snow thrower and void your warranty.



# REPAIR PARTS

# CONTROL PANEL / DISCHARGE CHUTE

SNOW THROWER - MODEL NO. **ST 261E** (96191003009), PRODUCT NO. 961 91 00-30

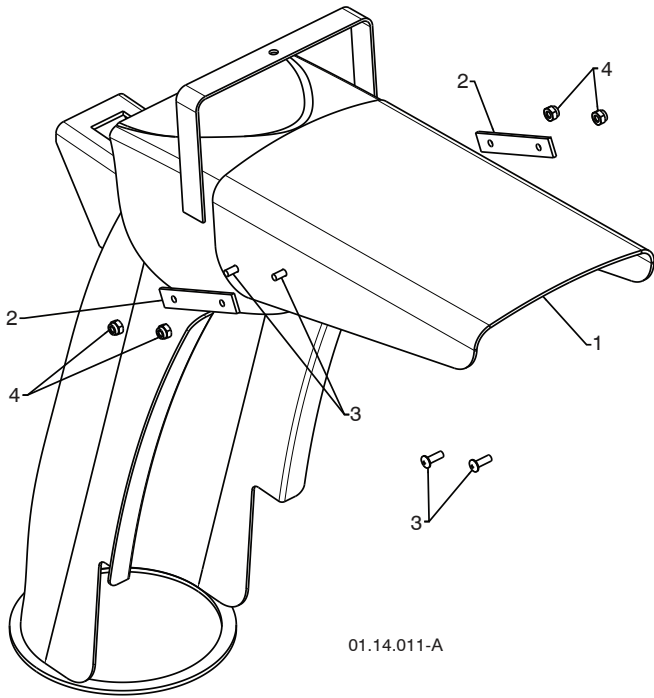

KEY NO.	PART NO.	DESCRIPTION
1	532 42 11-38	SHIELD DEFLECTOR
2	532 42 32-47	STRAP
3	532 18 22-27	SCREW 8-32 X .50
4	532 18 22-28	NUT 8-32

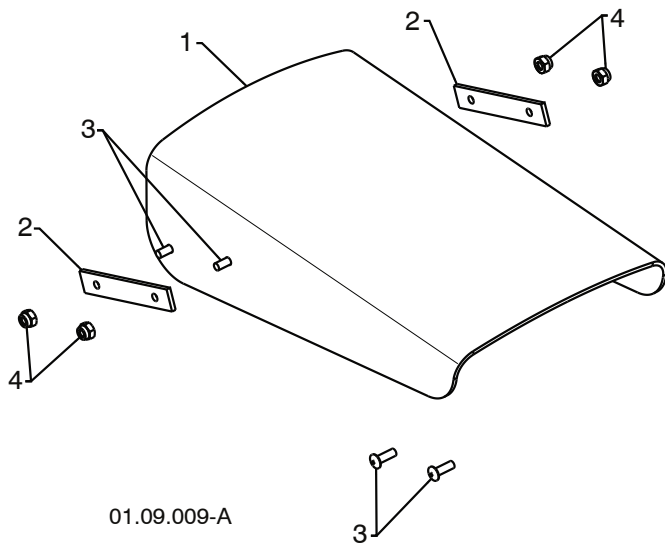

KEY NO.	PART NO.	DESCRIPTION
1	532 42 11-38	SHIELD DEFLECTOR
2	532 42 32-47	STRAP
3	532 18 22-27	SCREW 8-32 X .50
4	532 18 22-28	NUT 8-32

**NOTE:** All component dimensions given in U.S. inches. 1 inch = 25.4 mm  
**IMPORTANT:** Use only Original Equipment Manufacturer (O.E.M.) replacement parts.  
 Failure to do so could be hazardous, damage your snow thrower and void your warranty.

# REPAIR PARTS

# HANDLES

SNOW THROWER - MODEL NO. **ST 261E** (96191003009), PRODUCT NO. 961 91 00-30

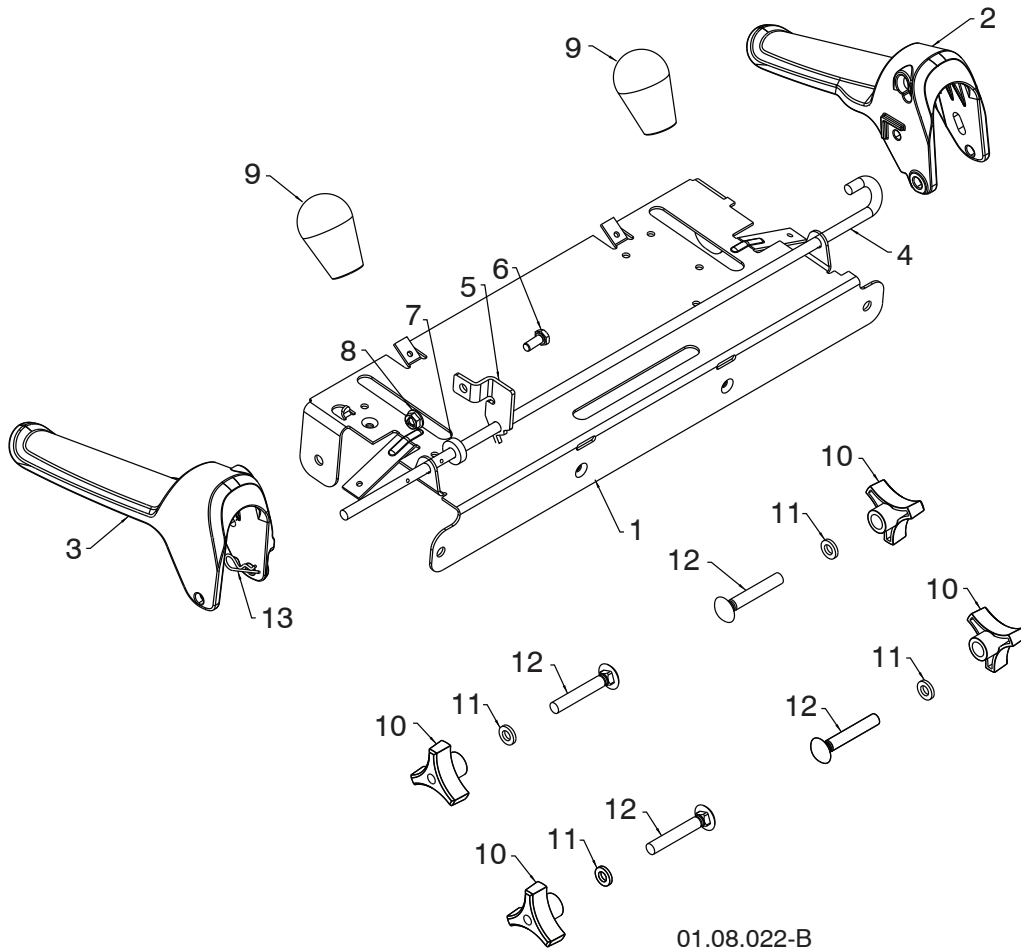

01.08.022-B

KEY NO.	PART NO.	DESCRIPTION
1	585 19 88-02	CONTROL PANEL
2	581 77 98-01	LH CONTROL LEVER
3	581 77 97-01	RH CONTROL LEVER
4	584 80 90-01	INTERLOCK CONTROL ROD
5	585 00 47-03	INTERLOCK BRACKET
6	874 78 04-10	1/4-20 X .625 HEX HEAD SCREW
7	532 42 16-13	SPACER
8	532 08 83-49	1/4-20 FLANGE NUT (TOP LOCK)
9	580 67 32-01	KNOB SOFT TOUCH
10	532 17 88-99	HANDLE KNOB
11	819 13 13-16	3/8 WASHER
12	872 12 06-18	CARRIAGE BOLT 3/8-16 X 2.25
13	532 16 96-75	RETAINER

**NOTE:** All component dimensions given in U.S. inches. 1 inch = 25.4 mm  
**IMPORTANT:** Use only Original Equipment Manufacturer (O.E.M.) replacement parts. Failure to do so could be hazardous, damage your snow thrower and void your warranty.

# REPAIR PARTS

# HANDLES

SNOW THROWER - MODEL NO. **ST 261E** (96191003009), PRODUCT NO. 961 91 00-30

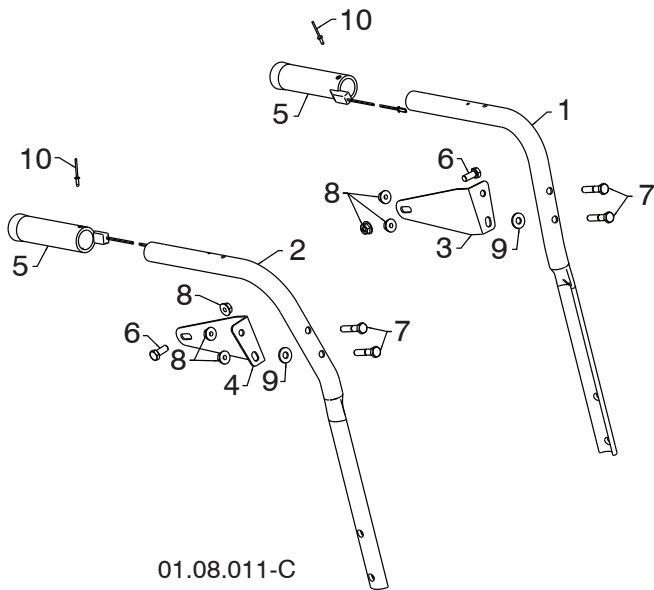

KEY NO.	PART NO.	DESCRIPTION
1	532 42 17-08	PLOW HANDLE LH
2	532 42 17-09	PLOW HANDLE RH
3	532 42 91-48	PANEL BRACKET LH
4	532 42 91-49	PANEL BRACKET RH
5	532 41 45-15	HEATED HANDLE GRIP
6	874 78 05-12	SCREW 5/16-18 X .750
7	874 78 05-24	SCREW 5/16-18 X 1.50
8	532 75 11-53	NUT 5/16-18
9	532 15 54-15	WASHER
10	532 17 87-75	POP RIVET 1/8

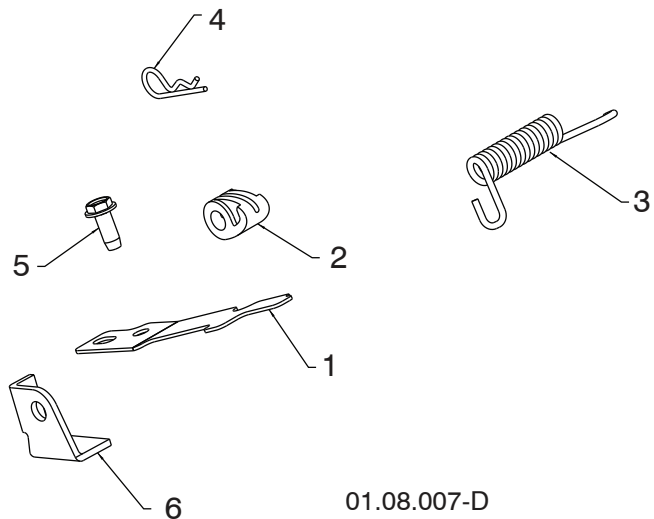

KEY NO.	PART NO.	DESCRIPTION
1	532 41 62-88	INTERLOCK SPRING
2	532 44 52-91	INTERLOCK CAM
3	532 44 32-15	TORSION SPRING
4	532 16 96-75	RETAINER
5	817 06 04-10	SCREW 1/4-20 X .625
6	532 42 18-14	INTERLOCK STOP

**NOTE:** All component dimensions given in U.S. inches. 1 inch = 25.4 mm  
**IMPORTANT:** Use only Original Equipment Manufacturer (O.E.M.) replacement parts.  
 Failure to do so could be hazardous, damage your snow thrower and void your warranty.

# REPAIR PARTS

# HANDLES

SNOW THROWER - MODEL NO. **ST 261E** (96191003009), PRODUCT NO. 961 91 00-30

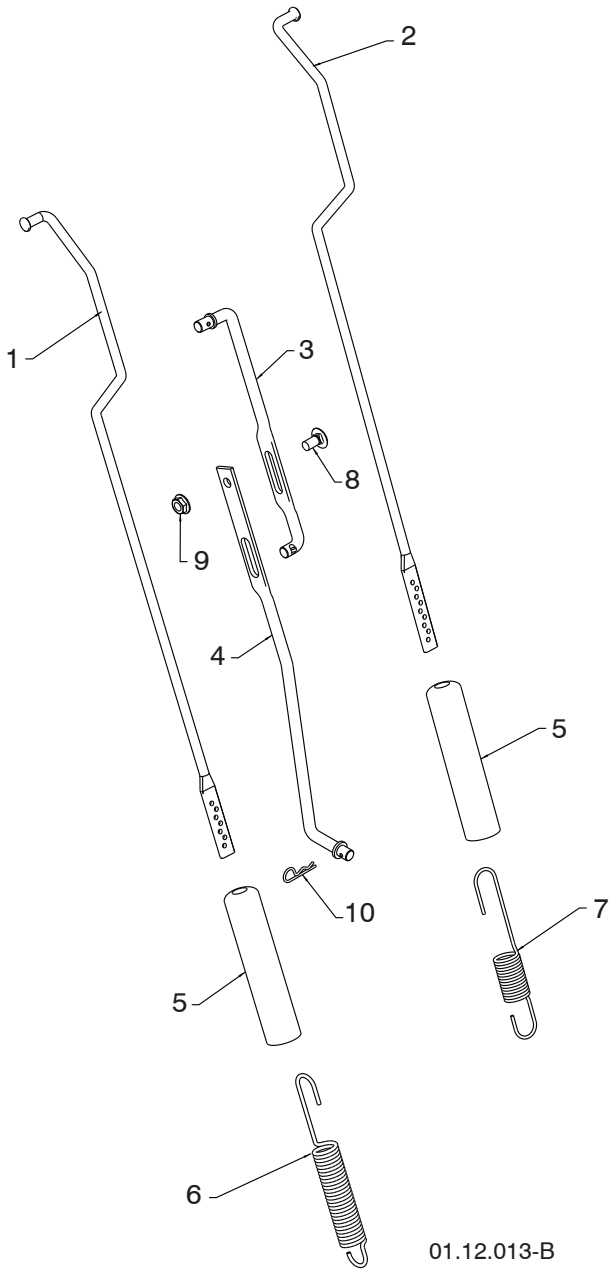

KEY NO.	PART NO.	DESCRIPTION
1	584 80 87-01	ROD IMPELLER CONTROL
2	584 80 88-01	ROD TRACTION CONTROL
3	532 18 04-45	SHIFTER ROD TOP
4	532 18 77-16	SHIFTER ROD BOTTOM
5	532 18 04-47	SPRING SLEEVE
6	580 79 62-01	SPRING CONTROL ROD
7	580 80 21-01	SPRING TRACTION ROD
8	872 27 05-05	CARRIAGE BOLT 5/16-18 X .75
9	532 15 53-77	NUT 5/16-18
10	532 16 96-75	RETAINER HAIRPIN

**NOTE:** HOOK TRACTION ROD SPRING IN HOLE 7  
HOOK IMPELLER ROD SPRING IN HOLE 4

01.12.013-B

**NOTE:** All component dimensions given in U.S. inches. 1 inch = 25.4 mm  
**IMPORTANT:** Use only Original Equipment Manufacturer (O.E.M.) replacement parts.  
Failure to do so could be hazardous, damage your snow thrower and void your warranty.

# REPAIR PARTS

# HANDLES

SNOW THROWER - MODEL NO. **ST 261E** (96191003009), PRODUCT NO. 961 91 00-30

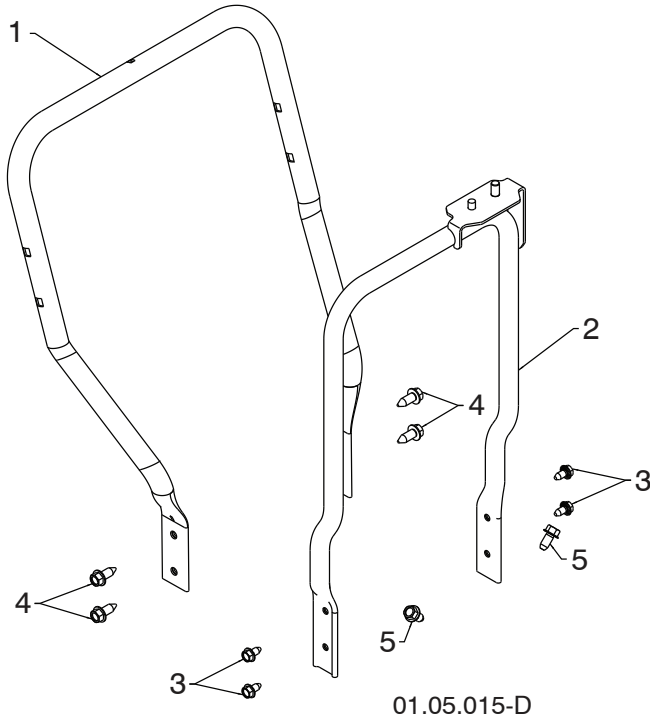

KEY NO.	PART NO.	DESCRIPTION
1	585 23 81-03	LOWER HANDLE
2	532 44 36-17	PIVOT SUPPORT WELDMENT
3	817 00 05-10	SCREW 5/16-18 X .750
4	817 00 06-16	SCREW 3/8-16 X 1.00
5	817 00 06-12	SCREW 3/8-16 X .750

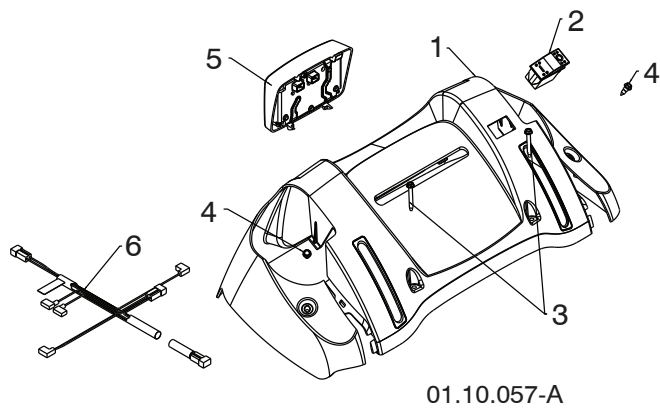

KEY NO.	PART NO.	DESCRIPTION
1	532 42 13-51	CONSOLE PANEL
2	532 41 77-60	SWITCH GRIP
3	532 17 52-62	SCREW HX WHSR HEAD 10-24 X 1.25
4	532 18 44-71	SCREW SHOULDER 10-24 X .62
5	581 68 42-01	LED LIGHT DUAL STAGE GRAY
6	580 62 56-01	WIRE HARNESS FLOOD / LED HEATED

**NOTE:** All component dimensions given in U.S. inches. 1 inch = 25.4 mm  
**IMPORTANT:** Use only Original Equipment Manufacturer (O.E.M.) replacement parts.  
 Failure to do so could be hazardous, damage your snow thrower and void your warranty.

# REPAIR PARTS

# DRIVE

SNOW THROWER - MODEL NO. **ST 261E** (96191003009), PRODUCT NO. 961 91 00-30

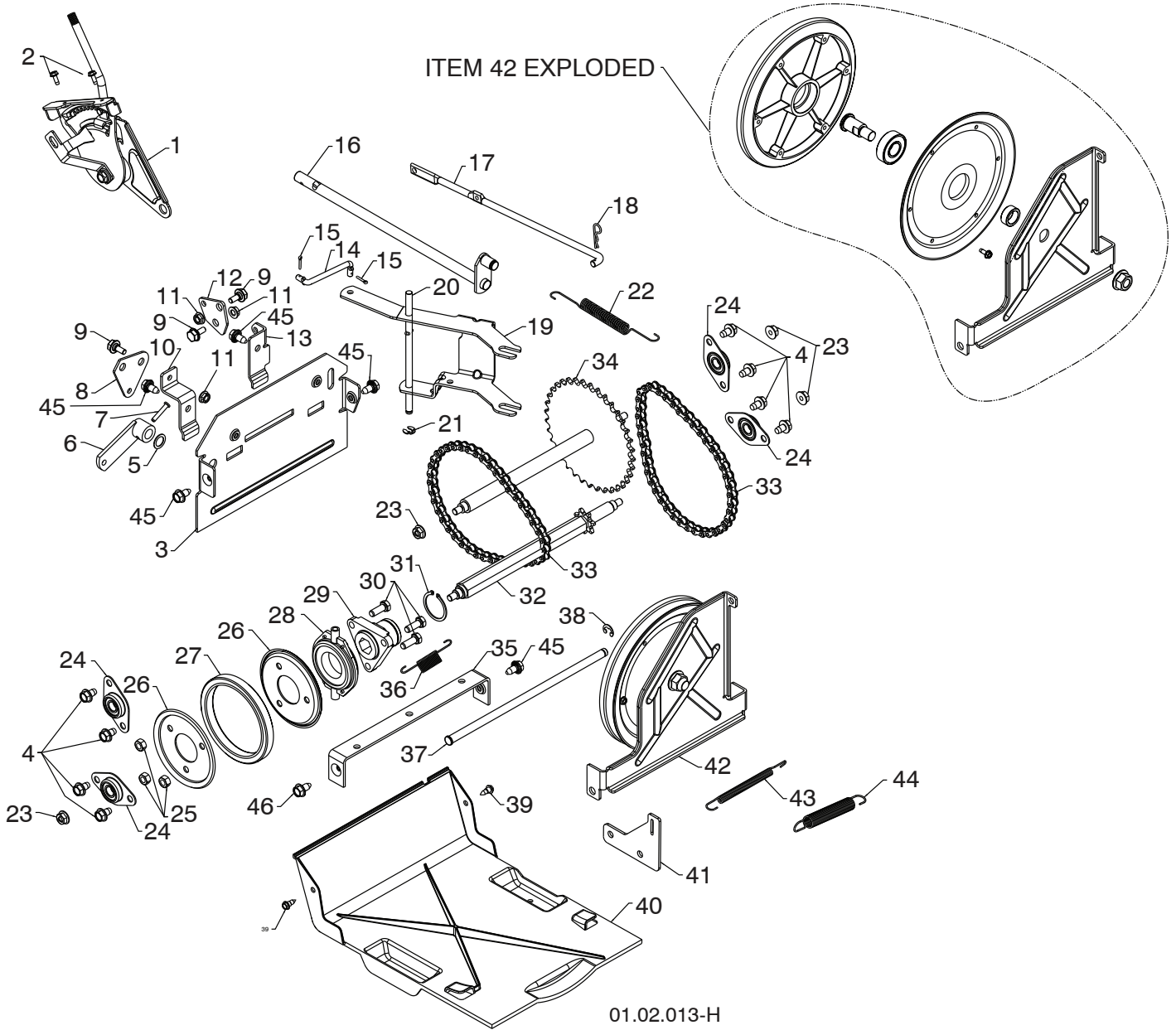

01.02.013-H

**NOTE:** All component dimensions given in U.S. inches. 1 inch = 25.4 mm  
**IMPORTANT:** Use only Original Equipment Manufacturer (O.E.M.) replacement parts.  
Failure to do so could be hazardous, damage your snow thrower and void your warranty.

**REPAIR PARTS****DRIVE****SNOW THROWER - MODEL NO. ST 261E (96191003009), PRODUCT NO. 961 91 00-30**

KEY NO.	PART NO.	DESCRIPTION	KEY NO.	PART NO.	DESCRIPTION
1	532 19 88-75	SPEED SELECTOR ASSEMBLY	24	532 40 89-81	BEARING
2	817 54 10-08	THRED ROLLING SCREW 10-24 X .500	25	873 93 05-00	NUT 5/16-18
3	532 43 60-80	END PLATE	26	532 19 95-09	RUBBER WHEEL PLATE
4	817 49 05-08	SCREW 5/16-18 X .50	27	585 02 10-01	RUBBER RING
5	532 05 70-79	WASHER	28	532 17 53-44	BEARING
6	532 40 54-85	CONTROL ARM	29	532 17 86-13	WHEEL HUB
7	532 19 85-80	CLEVIS PIN	30	874 76 05-14	SCREW 5/16-18-.875
8	532 41 54-50	SHIFTER PLATE	31	812 00 00-12	RETAINER RING
9	532 40 28-81	SHOULDER BOLT	32	532 40 21-87	SPROCKET SHAFT
10	532 41 54-33	SHIFTER BRACKET	33	532 40 16-19	CHAIN
11	532 19 17-30	NUT 1/4-20	34	532 43 73-03	SPROCKET WELDMENT
12	532 41 54-35	CLUTCH PLATE	35	532 41 54-29	SHIFTER BRACKET
13	532 41 68-64	CLUTCH BRACKET	36	532 18 01-35	SPRING
14	532 18 71-01	SHIFTER LINK	37	532 40 26-52	PLATE PIVOT ROD
15	532 70 02-79	RETAINER	38	532 42 82-88	E-RING .375
16	532 42 75-42	CONTROL SHAFT	39	532 18 44-71	SHOULDER SCREW
17	532 40 25-68	CLUTCH ROD	40	532 41 08-77	BOTTOM PAN
18	532 16 96-75	RETAINER	41	532 41 66-82	SPRING BRACKET
19	581 42 25-01	SHIFTER YOKE	42	585 11 12-01	DRIVE PLATE ASSEMBLY
20	532 40 23-10	PIVOT ROD	43	532 41 45-57	IDLER SPRING
21	812 00 00-36	RETAINER	44	532 17 88-28	IDLER SPRING
22	532 40 28-78	RETURN SPRING	45	532 42 88-67	SCREW 5/16-18 X .750
23	532 75 11-53	NUT 5/16-18	46	817 00 05-10	BOLT 5/16-18 X .625

**NOTE:** All component dimensions given in U.S. inches. 1 inch = 25.4 mm**IMPORTANT:** Use only Original Equipment Manufacturer (O.E.M.) replacement parts. Failure to do so could be hazardous, damage your snow thrower and void your warranty.

# REPAIR PARTS

# DRIVE

SNOW THROWER - MODEL NO. **ST 261E** (96191003009), PRODUCT NO. 961 91 00-30

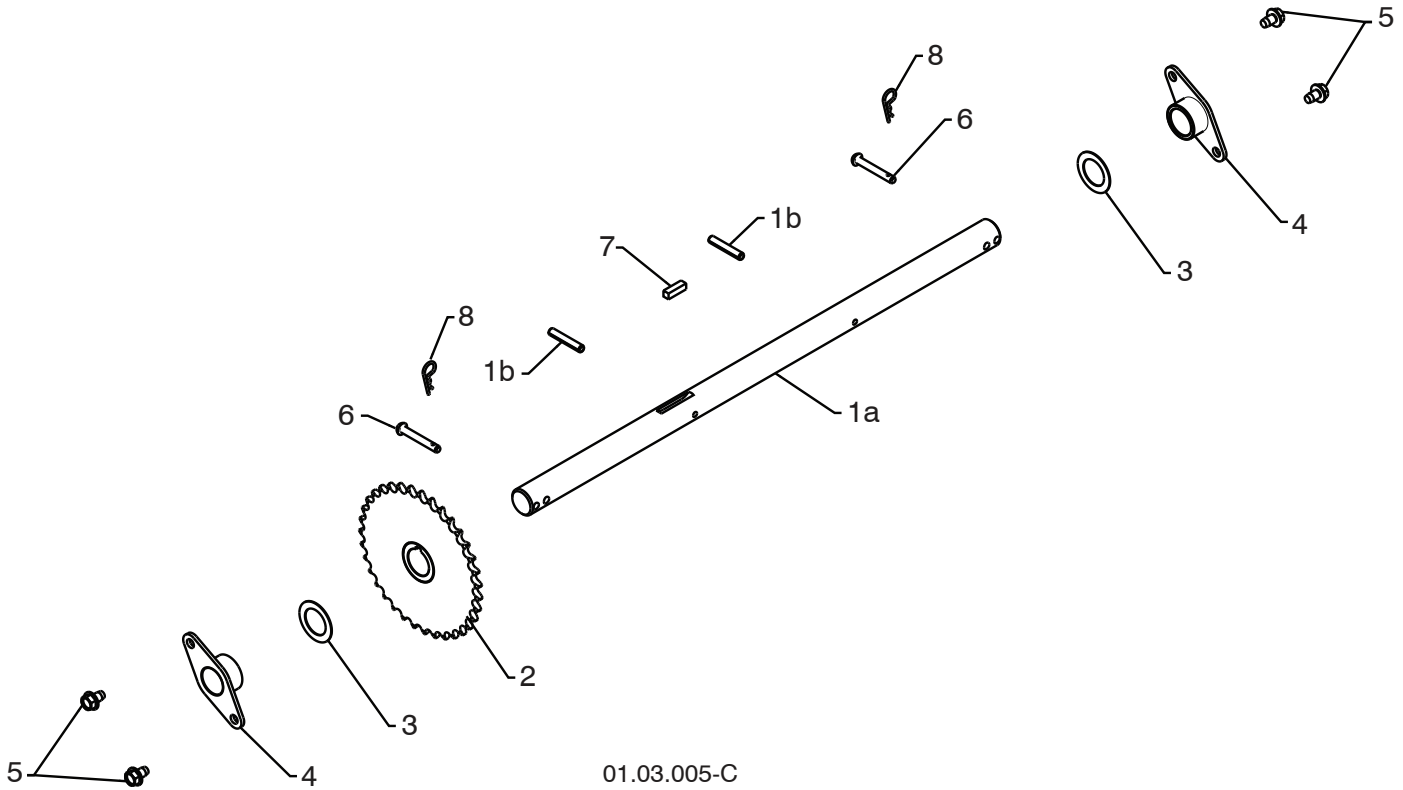

KEY NO.	PART NO.	DESCRIPTION
1	532 18 82-26	(assy of 1a,1b) AXLE ASSEMBLY
1a	532 17 93-52	AXLE SHAFT
1b	532 18 42-06	ROLL PIN 3/16
2	532 40 26-91	SPROCKET
3	532 44 49-49	THRUST WASHER
4	532 17 98-30	BEARING
5	817 49 05-08	BOLT 5/16-18 X .500
6	532 17 12-71	PIN
7	532 18 92-82	SQUARE KEY
8	532 12 47-88	RETAINER PIN

**NOTE:** All component dimensions given in U.S. inches. 1 inch = 25.4 mm  
**IMPORTANT:** Use only Original Equipment Manufacturer (O.E.M.) replacement parts. Failure to do so could be hazardous, damage your snow thrower and void your warranty.



# REPAIR PARTS

# CHASSIS / PULLEYS

SNOW THROWER - MODEL NO. **ST 261E** (96191003009), PRODUCT NO. 961 91 00-30

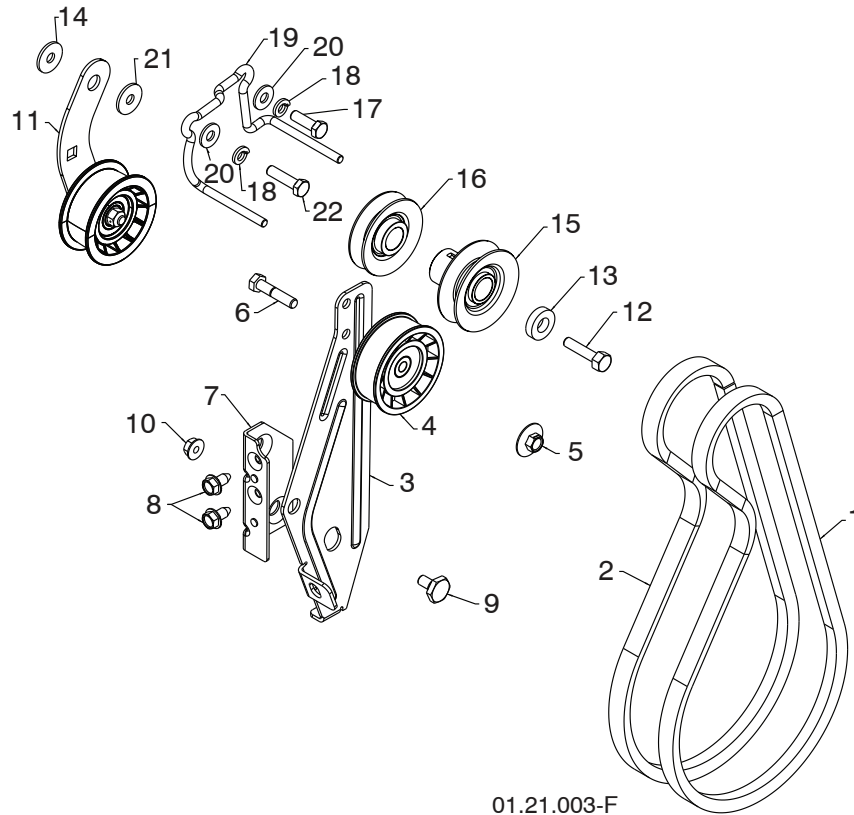

01.21.003-F

KEY NO.	PART NO.	DESCRIPTION	KEY NO.	PART NO.	DESCRIPTION
1	532 40 80-07	IMPELLER BELT	13	532 40 00-26	WASHER
2	532 41 97-44	TRACTION BELT	14	532 05 92-89	WASHER
3	584 23 24-02	IDLER ARM BRACKET	15	532 42 64-91	PULLEY ENG IMPELLER
4	532 18 05-23	IDLER PULLEY	16	532 42 64-90	PULLEY ENG TRACTION
5	532 42 65-89	NUT 5/16-18	17	874 61 05-16	SCREW 5/16-18 X 1.00
6	874 78 05-24	CAPSCREW 5/16-18 X 1.50	18	810 04 05-00	LOCKWASER 5/16
7	585 28 49-01	IDLER BRACKET	19	585 54 05-01	BELT GUIDE
8	817 00 05-10	SCREW 5/16-18 HEX	20	532 15 54-15	WASHER
9	532 42 42-97	SHOULDER BOLT 5/16-18 X .500	21	532 17 53-31	IDLER BUSHING
10	532 75 11-53	NUT 5/16-18 TOP LOCK	22	874 61 05-20	CAPSCREW HEX HEAD 5/16 X 1.25 GR5
11	585 23 84-01	TRACTION IDLER ARM ASM			
12	532 85 10-84	CAPSCREW 3/8-24 X 1.375			

**NOTE:** All component dimensions given in U.S. inches. 1 inch = 25.4 mm  
**IMPORTANT:** Use only Original Equipment Manufacturer (O.E.M.) replacement parts.  
 Failure to do so could be hazardous, damage your snow thrower and void your warranty.

# REPAIR PARTS

# CHASSIS / PULLEYS

SNOW THROWER - MODEL NO. **ST 261E** (96191003009), PRODUCT NO. 961 91 00-30

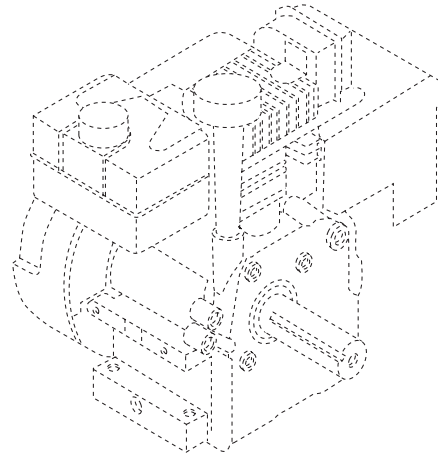
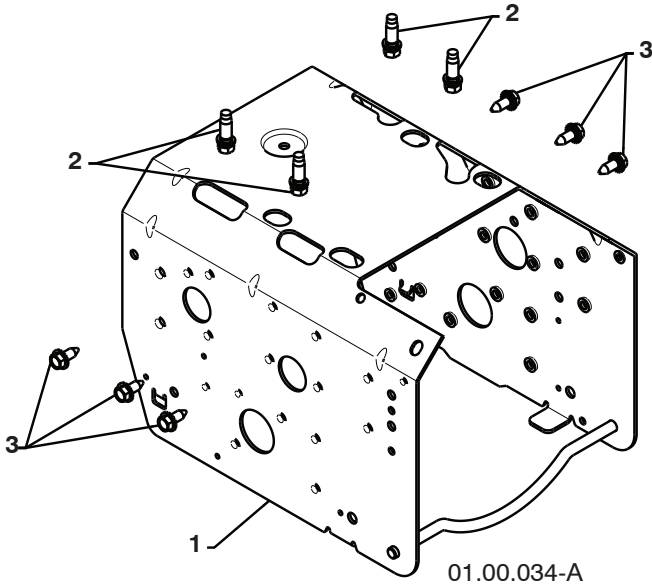

KEY NO.	PART NO.	DESCRIPTION
--	-----	B&S ENGINE 15C107-0002-F8
1	532 43 59-52	FRAME
2	532 15 04-06	BOLT 3/8-16
3	532 42 88-67	SCREW 5/16-18 X .750

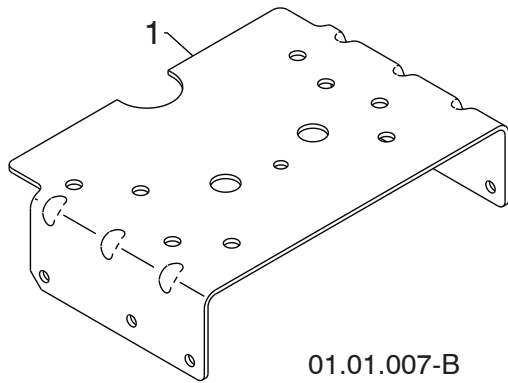

KEY NO.	PART NO.	DESCRIPTION
1	532 43 63-11	ENGINE MOUNT PLATE

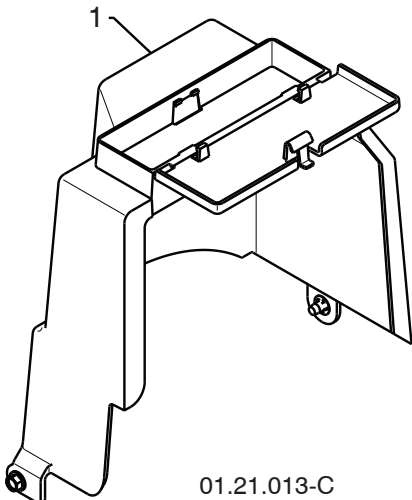

KEY NO.	PART NO.	DESCRIPTION
1	532 44 30-30	COVER ASSEMBLY

**NOTE:** All component dimensions given in U.S. inches. 1 inch = 25.4 mm  
**IMPORTANT:** Use only Original Equipment Manufacturer (O.E.M.) replacement parts.  
 Failure to do so could be hazardous, damage your snow thrower and void your warranty.

# REPAIR PARTS

# WHEELS

SNOW THROWER - MODEL NO. **ST 261E** (96191003009), PRODUCT NO. 961 91 00-30

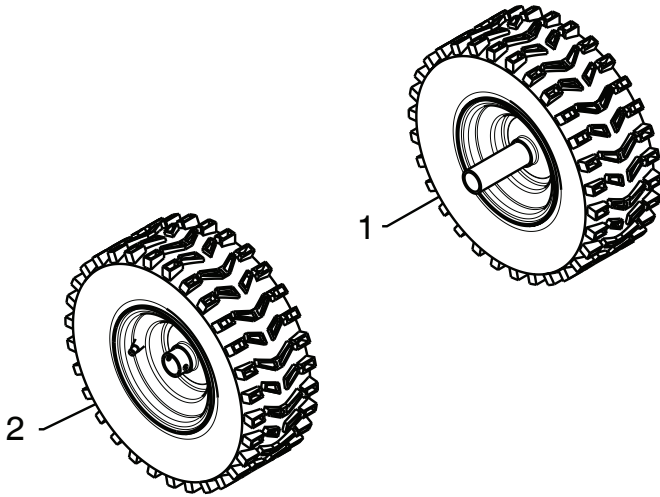

KEY NO.	PART NO.	DESCRIPTION
1	532 43 65-15	WHEEL 16 X 4.80 X LH
2	532 43 65-16	WHEEL 16 X 4.80 X RH

01.06.010-A

**NOTE:** All component dimensions given in U.S. inches. 1 inch = 25.4 mm  
**IMPORTANT:** Use only Original Equipment Manufacturer (O.E.M.) replacement parts.  
Failure to do so could be hazardous, damage your snow thrower and void your warranty.

# REPAIR PARTS

# BAG OF PARTS

SNOW THROWER - MODEL NO. **ST 261E** (96191003009), PRODUCT NO. 961 91 00-30

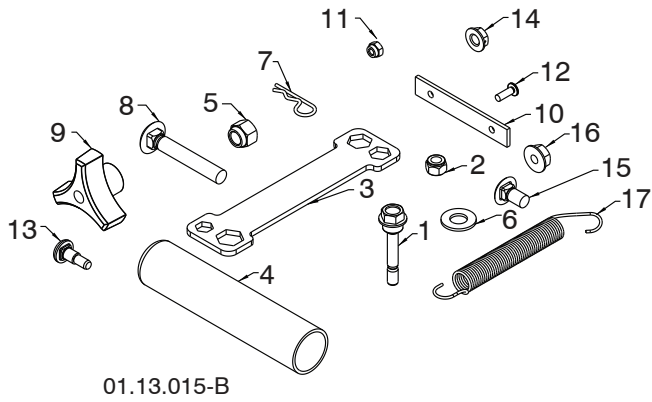

01.13.015-B

KEY NO.	PART NO.	DESCRIPTION
1	585 51 18-01	SCREW 1/4-20 X 1.81
2	873 80 04-00	NUT 1/4-20
3	532 42 91-12	WRENCH
4	532 18 04-47	SPRING SLEEVE
5	873 80 06-00	NUT HEX 3/8-16
6	819 13 13-16	WASHER 3/8 SAE
7	532 16 96-75	RETAINER HAIRPIN
8	872 12 06-18	BOLT 3/8-16 X 2.25
9	532 17 88-99	KNOB 3/8 TRI-LOBE
10	532 42 32-47	STRAP DEFLECTOR
11	532 18 22-28	NUT #8
12	532 18 22-27	SCREW #8 MACH
13	532 17 98-29	BOLT SHOULDER
14	532 19 17-30	NUT HEX 1/4-20 CTR
15	585 83 20-01	BOLT 5/16-18 X .625
16	532 75 11-53	NUT HEX 5/16-18
17	532 18 45-05	SPRING DEFLECT CHUTE

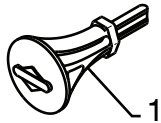

01.14.007-A

KEY NO.	PART NO.	DESCRIPTION
1	532 19 30-71	SAFETY IGNITION KEY

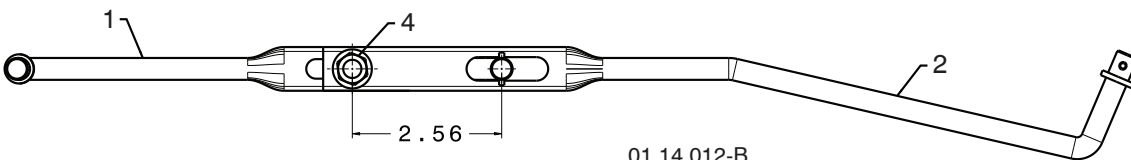
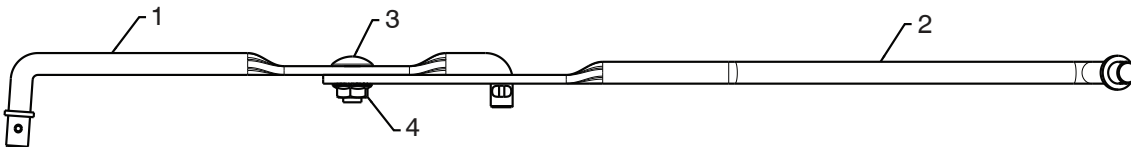

01.14.012-B

KEY NO.	PART NO.	DESCRIPTION
1	532 18 04-45	SHIFTER ROD TOP
2	532 18 77-16	SHIFTER ROD BOTTOM
3	872 27 05-05	CARRIAGE BOLT 5/16-18 X .75
4	532 15 53-77	NUT 5/16-18

**NOTE:** All component dimensions given in U.S. inches. 1 inch = 25.4 mm  
**IMPORTANT:** Use only Original Equipment Manufacturer (O.E.M.) replacement parts. Failure to do so could be hazardous, damage your snow thrower and void your warranty.

# REPAIR PARTS

# DECALS

SNOW THROWER - MODEL NO. **ST 261E** (96191003009), PRODUCT NO. 961 91 00-30

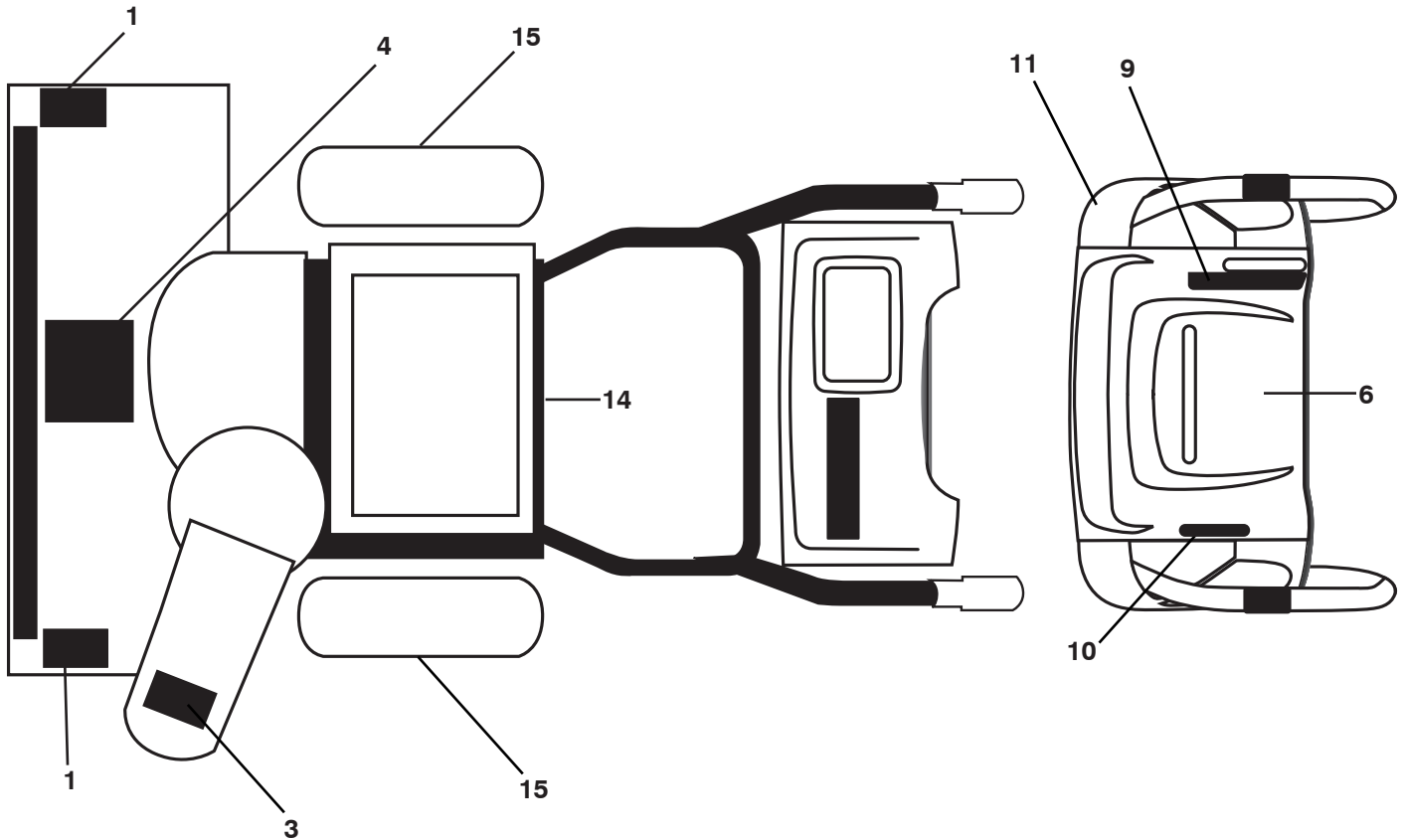

**KEY PART  
NO. NO.**

**DESCRIPTION**

1	532 19 96-83	DECAL, DANGER
3	532 19 96-82	DECAL, DANGER, DEFLECTOR
4	532 18 40-45	DECAL, DANGER
6	532 42 95-75	DECAL, INSTRUCTION
9	585 76 87-02	DECAL, LH
10	585 76 87-01	DECAL, RH
11	532 44 47-68	DECAL, HANDWARMER
14	532 18 04-33	DECAL, SOUND LEVEL
15	532 18 40-28	DECAL, BELT GUARD
--	115 61 37-20	OPERATOR'S MANUAL, EUROPEAN
--	115 61 38-10	OPERATOR'S MANUAL, SCANDINAVIAN
--	115 61 39-50	OPERATOR'S MANUAL, EAST BLOC
--	115 61 41-40	OPERATOR'S MANUAL, BALTIC

**NOTE:** All component dimensions given in U.S. inches. 1 inch = 25.4 mm

**IMPORTANT:** Use only Original Equipment Manufacturer (O.E.M.) replacement parts. Failure to do so could be hazardous, damage your snow thrower and void your warranty.

