

**ILLUSTRATED PARTS LIST**

**MODEL NUMBER ST 324P**  
**PRODUCT NUMBER 961 91 00-82**  
**MFG. ID. NUMBER 96191008200**

# REPAIR PARTS

# AUGER HOUSING / IMPELLER ASSEMBLY

SNOW THROWER - MODEL NO. **ST 324P** (96191008200), PRODUCT NO. 961 91 00-82

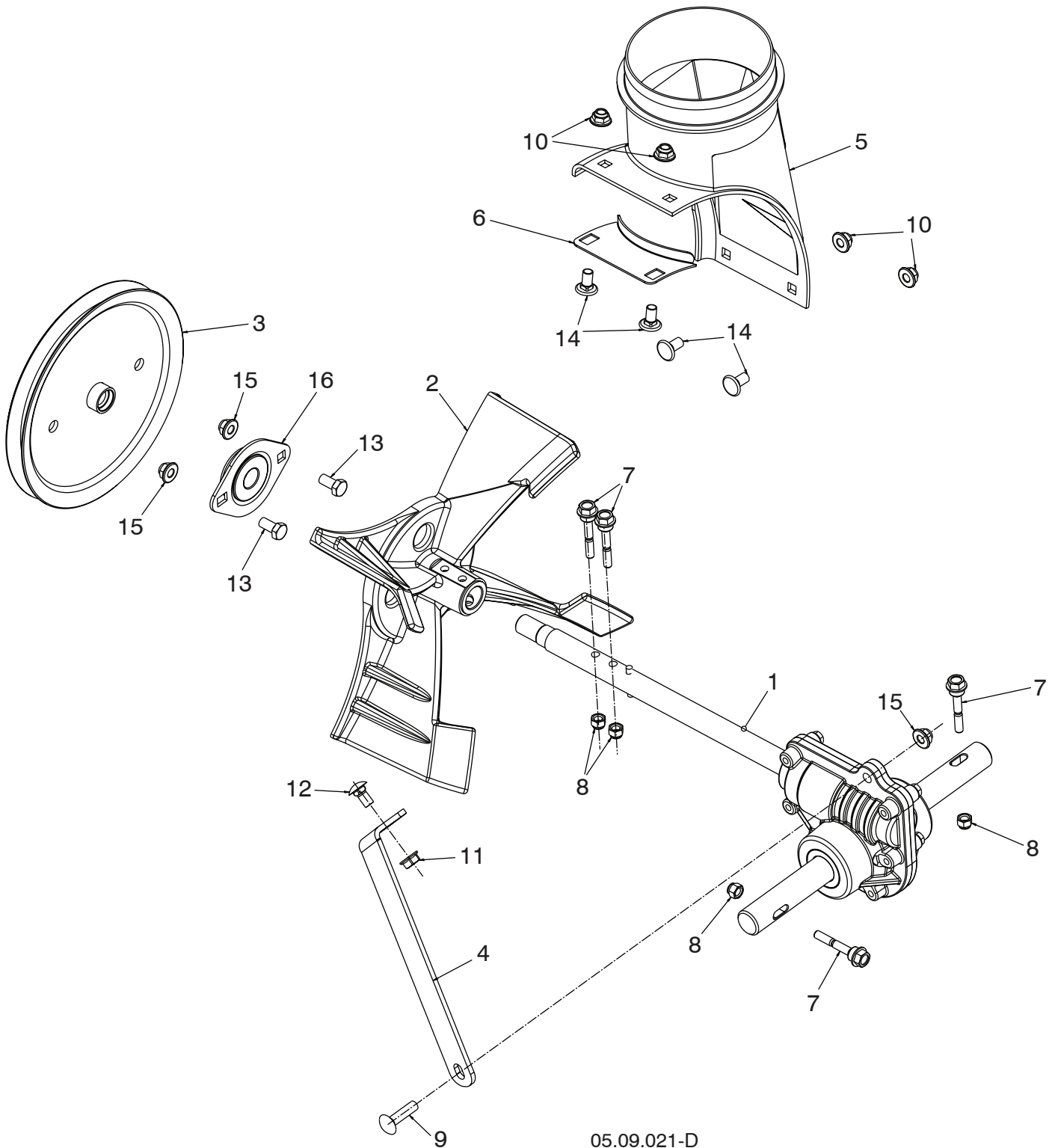

05.09.021-D

**NOTE:** All component dimensions given in U.S. inches. 1 inch = 25.4 mm  
**IMPORTANT:** Use only Original Equipment Manufacturer (O.E.M.) replacement parts.  
Failure to do so could be hazardous, damage your snow thrower and void your warranty.

## REPAIR PARTS

## AUGER HOUSING / IMPELLER ASSEMBLY

SNOW THROWER - MODEL NO. **ST 324P** (96191008200), PRODUCT NO. 961 91 00-82

KEY NO.	PART NO.	DESCRIPTION
1	586 71 50-01	GEARBOX AUGER CAST IRON 5/8 THREAD
2	585 19 83-03	IMPELLER CAST IRON
3	586 71 54-01	PULLEY IMPELLER 7.9 SCREW ON
4	585 10 90-04	SUPPORT GEARBOX – GREY
5	585 05 69-01	CHUTE DISCHARGE BASE
6	532 18 40-95	BRACKET CORNER DISCHARGE BASE
7	585 51 18-01	BOLT SHEAR 1/4-20
8	873 80 04-00	NUT NYLOCK 1/4-20
9	872 11 05-10	BOLT CARRIAGE 5/16-18 X 1-1/4
10	585 69 13-01	NUT FLANGE NYLOCK 5/16-18 – BLK
11	532 75 11-53	NUT FLANGE TOP LOCK 5/16-18
12	585 83 20-01	BOLT CARRIAGE 5/16-18 X 5/8 – BLK
13	532 16 31-83	SCREW HEX HEAD 5/16-18 X 5/8
14	585 69 12-01	BOLT CARRIAGE WAFER HEAD 5/16-18 X 5/8 – BLK
15	532 42 79-42	NUT FLANGE NYLOCK 5/16-18
16	532 18 89-09	BEARING FLANGE

**NOTE:** All component dimensions given in U.S. inches. 1 inch = 25.4 mm

**IMPORTANT:** Use only Original Equipment Manufacturer (O.E.M.) replacement parts. Failure to do so could be hazardous, damage your snow thrower and void your warranty.

# REPAIR PARTS

# AUGER HOUSING / IMPELLER ASSEMBLY

SNOW THROWER - MODEL NO. **ST 324P** (96191008200), PRODUCT NO. 961 91 00-82

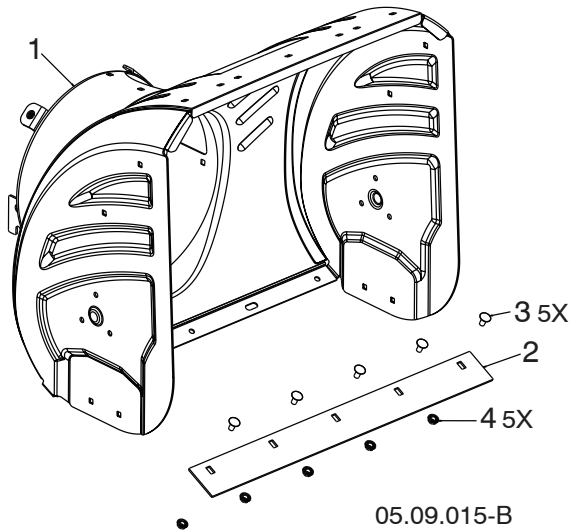

KEY NO.	PART NO.	DESCRIPTION
1	581 97 67-02	AUGER HOUSING 24 LS
2	585 04 83-02	SHAVE PLATE 24 LS MS428
3	872 27 05-05	BOLT CARRIAGE 5/16-18 X .625
4	532 15 53-77	NUT 5/16-18 HEX TOP LOCK

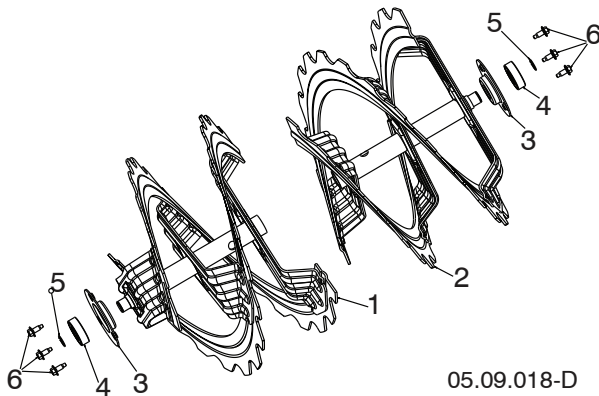

KEY NO.	PART NO.	DESCRIPTION
1	581 97 01-03	AUGER RIBBON 24 RH LS
2	581 97 02-03	AUGER RIBBON 24 LH LS
3	580 85 55-01	SUPPORT AUGER BEARING
4	532 43 76-22	BEARING IDLER 6203
5	812 00 00-28	RING RETAINING #5100-52
6	585 51 78-01	SCREW 1/4-20 X .65 W/DOG POINT

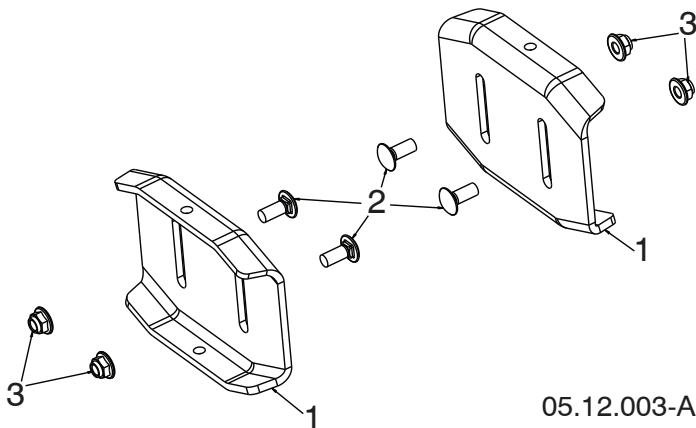

KEY NO.	PART NO.	DESCRIPTION
1	532 40 78-34	SKID SHOW UHMW
2	585 69 17-01	BOLT CARR BLK 5/16-18 X 1.25
3	585 69 13-01	NUT HEX 5/16-18 LRG FLG

**NOTE:** All component dimensions given in U.S. inches. 1 inch = 25.4 mm  
**IMPORTANT:** Use only Original Equipment Manufacturer (O.E.M.) replacement parts.  
 Failure to do so could be hazardous, damage your snow thrower and void your warranty.

# REPAIR PARTS

# AUGER HOUSING / IMPELLER ASSEMBLY

SNOW THROWER - MODEL NO. **ST 324P** (96191008200), PRODUCT NO. 961 91 00-82

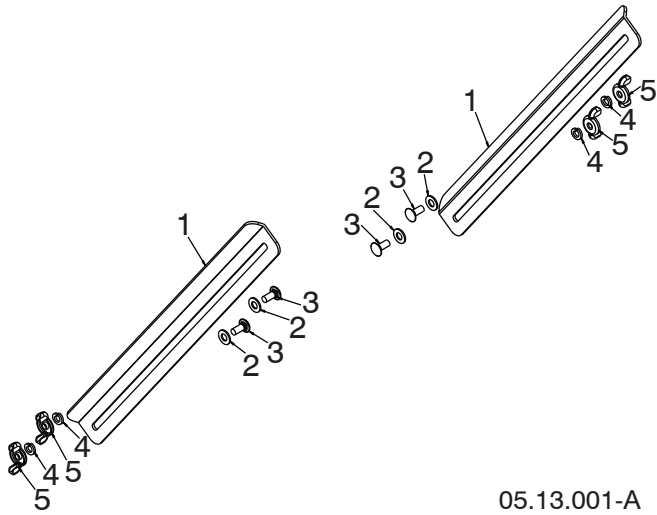

KEY NO.	PART NO.	DESCRIPTION
1	532 18 47-47	DRIFT BAR CUTTER
2	532 17 92-46	WASHER FRICTION NYLON
3	872 27 05-06	CARRIAGE BOLT 5/16-18 X .75 GR5
4	810 04 05-00	LOCKWASHER 5/16 SPLIT
5	532 12 86-38	WING NUT 5/16-18 ZINC

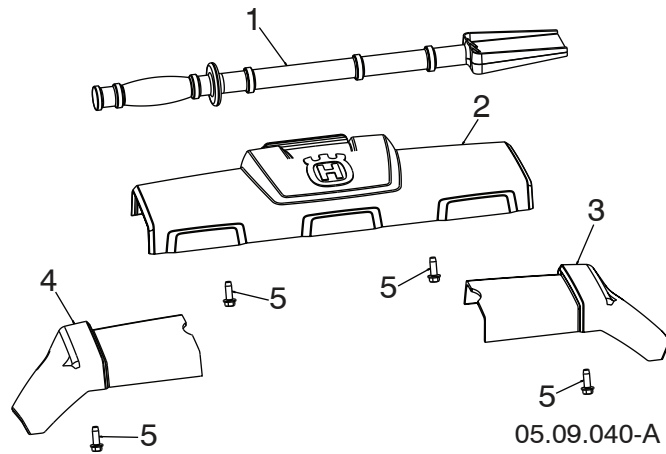

KEY NO.	PART NO.	DESCRIPTION
1	532 19 21-99	TOOL CLEANOUT
2	586 41 48-01	TRIM AUGER HOUSING FRONT ASM
3	586 33 03-02	TRIM AUGER HOUSING WING RH
4	586 33 04-02	TRIM AUGER HOUSING WING LH
5	817 67 04-12	SCREW HEX WASHER TRI-LOBE 1/4-20 X 3/4

**NOTE:** All component dimensions given in U.S. inches. 1 inch = 25.4 mm  
**IMPORTANT:** Use only Original Equipment Manufacturer (O.E.M.) replacement parts.  
 Failure to do so could be hazardous, damage your snow thrower and void your warranty.

# REPAIR PARTS

# CONTROL PANEL / DISCHARGE CHUTE

SNOW THROWER - MODEL NO. **ST 324P** (96191008200), PRODUCT NO. 961 91 00-82

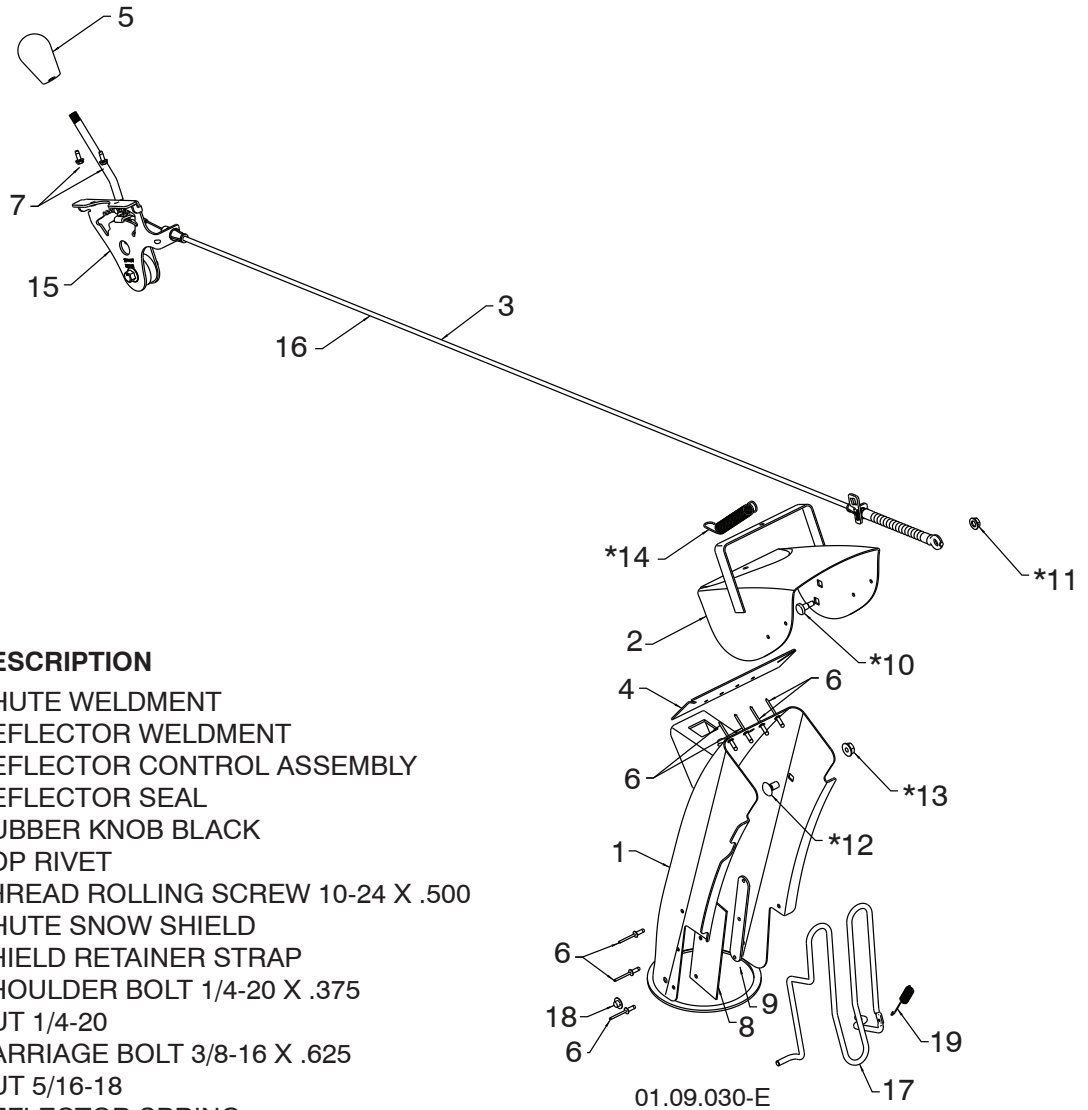

KEY NO.	PART NO.	DESCRIPTION
1	532 44 40-41	CHUTE WELDMENT
2	532 18 41-13	DEFLECTOR WELDMENT
3	587 03 08-01	DEFLECTOR CONTROL ASSEMBLY
4	532 42 03-25	DEFLECTOR SEAL
5	580 67 32-01	RUBBER KNOB BLACK
6	532 12 84-15	POP RIVET
7	817 54 10-08	THREAD ROLLING SCREW 10-24 X .500
8	532 43 03-24	CHUTE SNOW SHIELD
9	532 42 17-28	SHIELD RETAINER STRAP
*10	532 17 98-29	SHOULDER BOLT 1/4-20 X .375
*11	532 19 17-30	NUT 1/4-20
*12	872 25 05-05	CARRIAGE BOLT 3/8-16 X .625
*13	532 75 11-53	NUT 5/16-18
*14	532 18 45-05	DEFLECTOR SPRING
15	532 42 06-79	(SERVICE PART) DEFLECTOR CONTROL
16	587 03 09-01	(SERVICE PART) DEFLECTOR CABLE BLACK
17	532 43 55-82	CHUTE GUARD
18	532 05 93-49	PUSH NUT
19	532 43 56-16	SPRING

### NOTE:

1. ALL ITEMS INDICATED WITH AN \* ARE PROVIDED IN THE BAG OF ITEMS SHIPPED LOOSE WITH PRODUCT.
2. ITEMS 15 AND 16 ARE SERVICE PART NUMBERS TO ALLOW PURCHASE OF INDIVIDUAL ITEMS IF NECESSARY.

**NOTE:** All component dimensions given in U.S. inches. 1 inch = 25.4 mm  
**IMPORTANT:** Use only Original Equipment Manufacturer (O.E.M.) replacement parts.  
Failure to do so could be hazardous, damage your snow thrower and void your warranty.

# REPAIR PARTS

# CONTROL PANEL / DISCHARGE CHUTE

SNOW THROWER - MODEL NO. **ST 324P** (96191008200), PRODUCT NO. 961 91 00-82

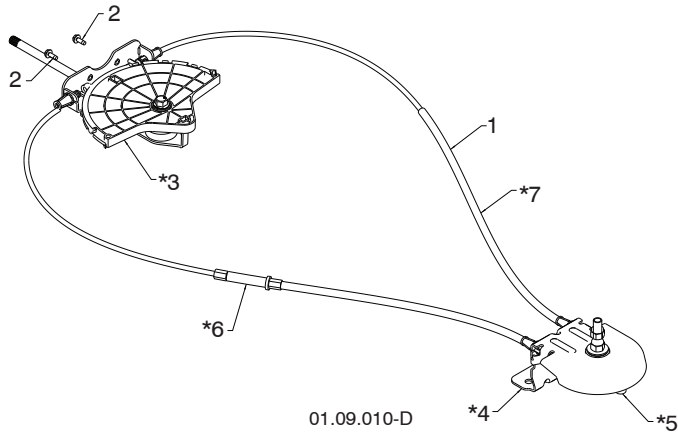

01.09.010-D

KEY NO.	PART NO.	DESCRIPTION
1	532 42 82-72	LEVER/CABLE ROTATOR ASSEMBLY
2	817 54 10-08	THREAD ROLLING SCREW 10-24 X .500
*3	532 42 06-78	ROTATOR HEAD
*4	585 19 92-01	ROTATOR PIVOT BRACKET
*5	532 42 06-75	PULLEY PIVOT
*6	532 42 82-73	CABLE ASSEMBLY ADJUSTABLE
*7	532 42 83-10	CABLE ASSEMBLY HEAT SHIELD

**NOTES:**

1. ITEMS INDICATED WITH AN \* ARE LISTED AS REFERENCE FOR SERVICE PARTS ONLY.

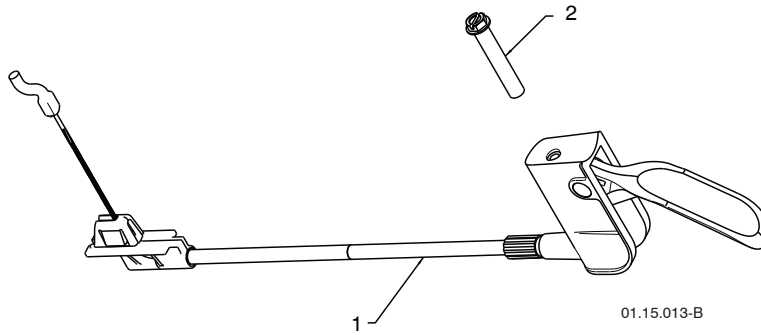

01.15.013-B

KEY NO.	PART NO.	DESCRIPTION
1	532 42 57-99	STEER CABLE
2	874 04 10-24	SCREW 10-24 X 1.50

**NOTE:** All component dimensions given in U.S. inches. 1 inch = 25.4 mm  
**IMPORTANT:** Use only Original Equipment Manufacturer (O.E.M.) replacement parts. Failure to do so could be hazardous, damage your snow thrower and void your warranty.

# REPAIR PARTS

# CONTROL PANEL / DISCHARGE CHUTE

SNOW THROWER - MODEL NO. **ST 324P** (96191008200), PRODUCT NO. 961 91 00-82

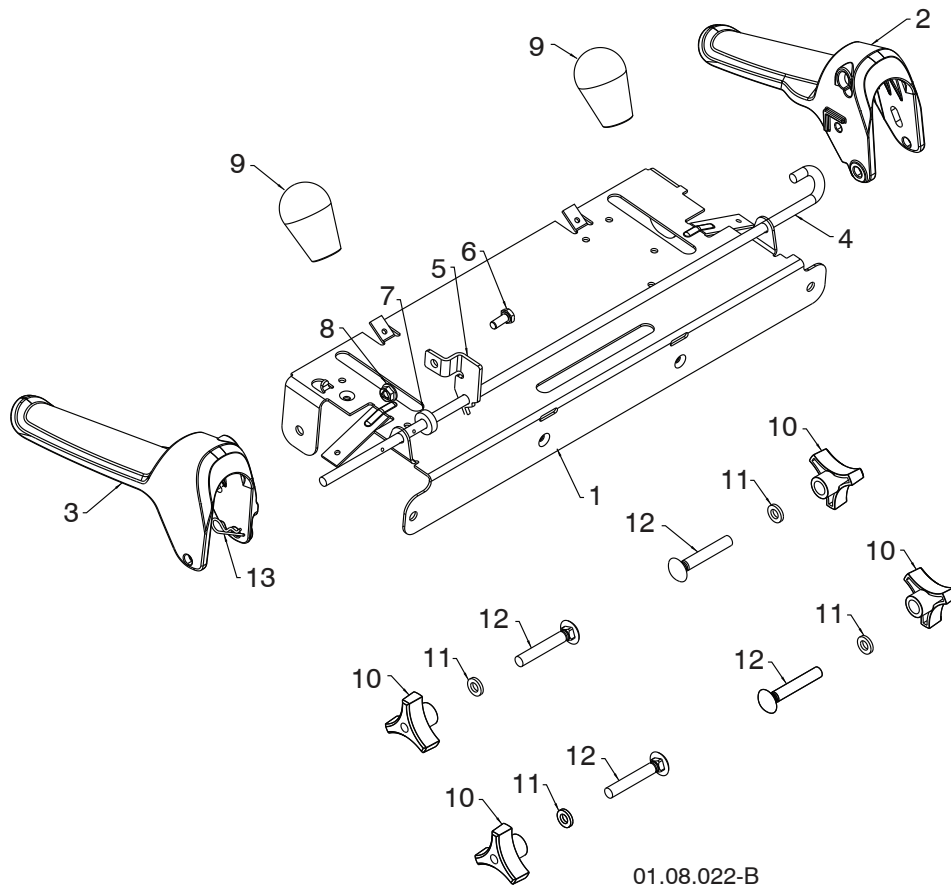

KEY NO.	PART NO.	DESCRIPTION
1	585 19 88-02	CONTROL PANEL
2	581 77 98-01	LH CONTROL LEVER
3	581 77 97-01	RH CONTROL LEVER
4	584 80 90-01	INTERLOCK CONTROL ROD
5	585 00 47-03	INTERLOCK BRACKET
6	874 78 04-10	1/4-20 X .625 HEX HEAD SCREW
7	532 42 16-13	SPACER
8	532 08 83-49	1/4-20 FLANGE NUT (TOP LOCK)
9	580 67 32-01	KNOB SOFT TOUCH
10	532 17 88-99	HANDLE KNOB
11	819 13 13-16	3/8 WASHER
12	872 12 06-18	CARRIAGE BOLT 3/8-16 X 2.25
13	532 16 96-75	RETAINER

**NOTE:** All component dimensions given in U.S. inches. 1 inch = 25.4 mm  
**IMPORTANT:** Use only Original Equipment Manufacturer (O.E.M.) replacement parts. Failure to do so could be hazardous, damage your snow thrower and void your warranty.



# REPAIR PARTS

# CONTROL PANEL / DISCHARGE CHUTE

SNOW THROWER - MODEL NO. **ST 324P** (96191008200), PRODUCT NO. 961 91 00-82

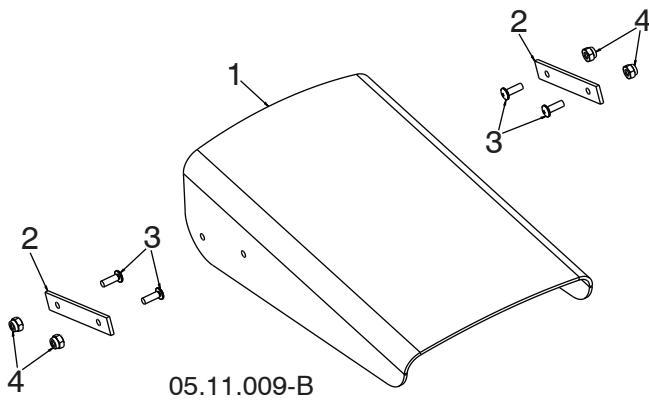

05.11.009-B

KEY NO.	PART NO.	DESCRIPTION
1	532 42 11-38	SHIELD DEFLECTOR
2	532 42 32-47	STRAP
3	586 11 80-01	SCREW MACHINE 8-32 X .50 - BLK
4	586 11 81-01	NUT HEX NYLOCK 8-32 - BLK

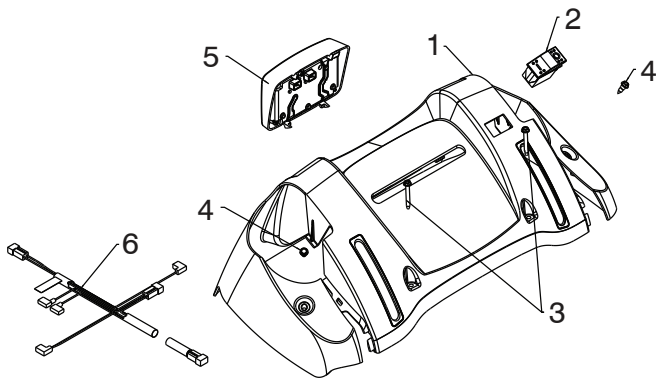

01.10.057-A

KEY NO.	PART NO.	DESCRIPTION
1	532 42 13-51	CONSOLE PANEL
2	532 41 77-60	SWITCH GRIP
3	532 17 52-62	SCREW HX WHSR HEAD 10-24 X 1.25
4	532 18 44-71	SCREW SHOULDER 10-24 X .62
5	581 68 42-01	LED LIGHT DUAL STAGE GRAY
6	580 62 56-01	WIRE HARNESS FLOOD / LED HEATED

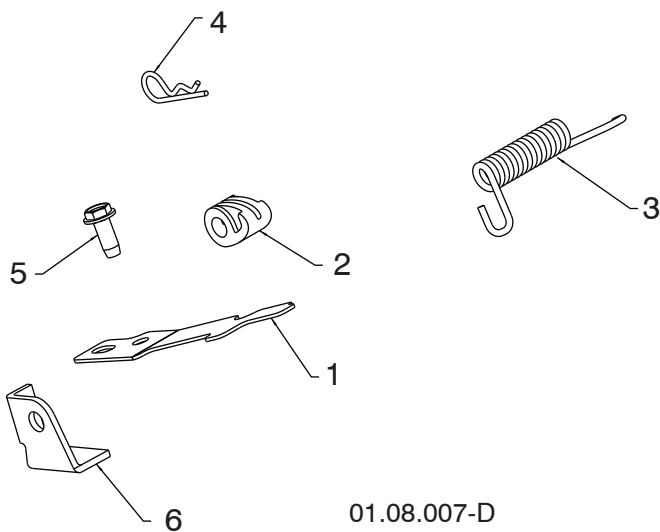

01.08.007-D

KEY NO.	PART NO.	DESCRIPTION
1	532 41 62-88	INTERLOCK SPRING
2	532 44 52-91	INTERLOCK CAM
3	532 44 32-15	TORSION SPRING
4	532 16 96-75	RETAINER
5	817 06 04-10	SCREW 1/4-20 X .625
6	532 42 18-14	INTERLOCK STOP

**NOTE:** All component dimensions given in U.S. inches. 1 inch = 25.4 mm  
**IMPORTANT:** Use only Original Equipment Manufacturer (O.E.M.) replacement parts.  
 Failure to do so could be hazardous, damage your snow thrower and void your warranty.

# REPAIR PARTS

# HANDLES

SNOW THROWER - MODEL NO. **ST 324P** (96191008200), PRODUCT NO. 961 91 00-82

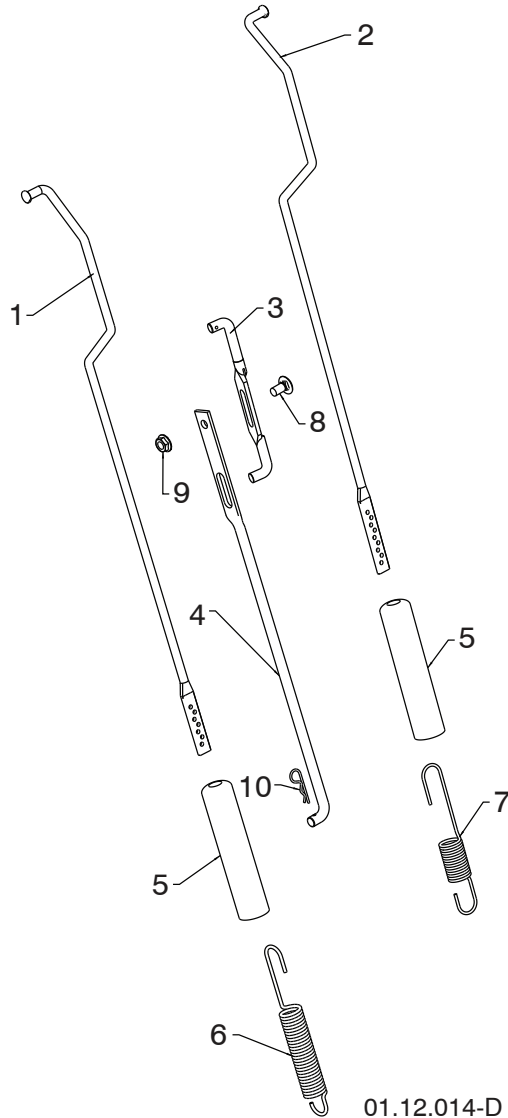

KEY NO.	PART NO.	DESCRIPTION
1	584 80 87-01	ROD IMPELLER CONTROL
2	584 80 88-01	ROD TRACTION CONTROL
3	532 42 55-98	SHIFTER ROD TOP
4	532 18 77-84	SHIFTER ROD BOTTOM
5	532 18 04-47	SPRING SLEEVE
6	580 79 62-01	SPRING CONTROL ROD
7	580 80 21-01	SPRING TRACTION ROD
8	872 27 05-05	CARRIAGE BOLT 5/16-18 X .75
9	532 15 53-77	NUT 5/16-18
10	532 16 96-75	RETAINER HAIRPIN

**NOTE:** HOOK TRACTION ROD SPRING IN HOLE 9  
HOOK IMPELLER ROD SPRING IN HOLE 4

01.12.014-D

**NOTE:** All component dimensions given in U.S. inches. 1 inch = 25.4 mm  
**IMPORTANT:** Use only Original Equipment Manufacturer (O.E.M.) replacement parts.  
Failure to do so could be hazardous, damage your snow thrower and void your warranty.

# REPAIR PARTS

# HANDLES

SNOW THROWER - MODEL NO. **ST 324P** (96191008200), PRODUCT NO. 961 91 00-82

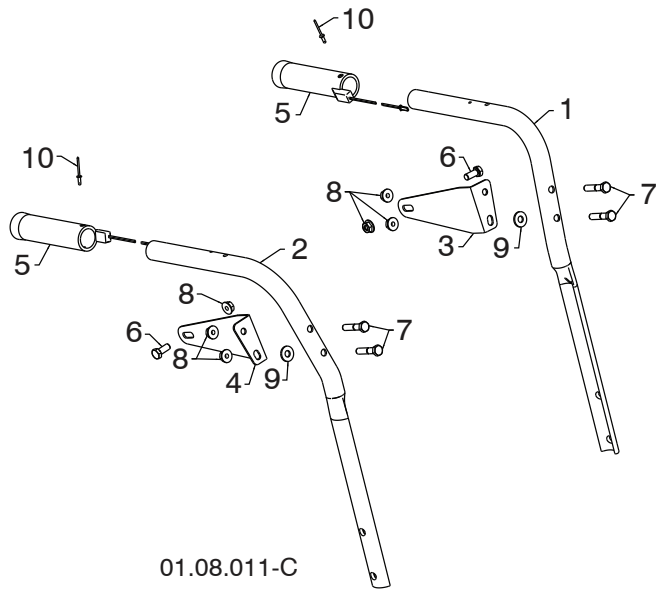

01.08.011-C

KEY NO.	PART NO.	DESCRIPTION
1	532 42 17-08	PLOW HANDLE LH
2	532 42 17-09	PLOW HANDLE RH
3	532 42 91-48	PANEL BRACKET LH
4	532 42 91-49	PANEL BRACKET RH
5	532 41 45-15	HEATED HANDLE GRIP
6	874 78 05-12	SCREW 5/16-18 X .750
7	874 78 05-24	SCREW 5/16-18 X 1.50
8	532 75 11-53	NUT 5/16-18
9	532 15 54-15	WASHER
10	532 17 87-75	POP RIVET 1/8

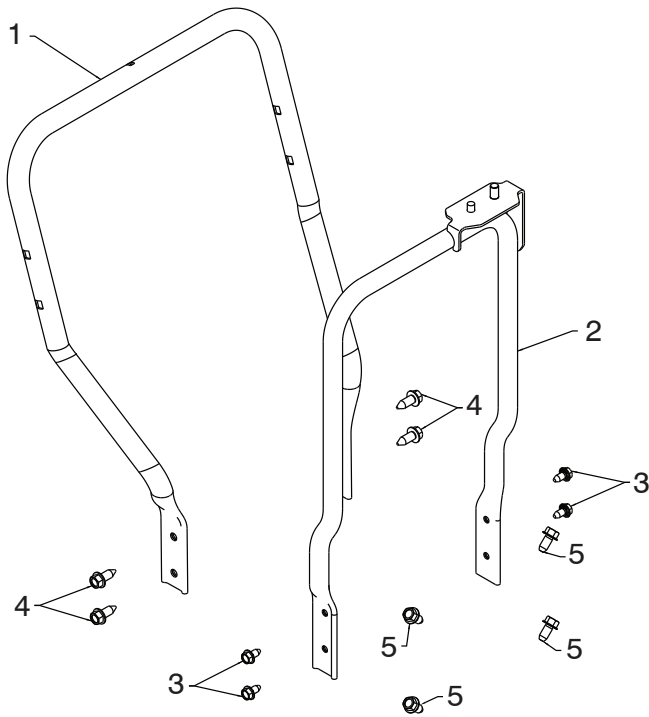

01.05.017-A

KEY NO.	PART NO.	DESCRIPTION
1	585 23 81-03	LOWER HANDLE
2	532 44 36-17	PIVOT SUPPORT WELDMENT
3	817 00 05-10	SCREW 5/16-18 X .750
4	817 00 06-16	SCREW 3/8-16 X 1.00
5	817 00 06-12	SCREW 3/8-16 X .750

**NOTE:** All component dimensions given in U.S. inches. 1 inch = 25.4 mm  
**IMPORTANT:** Use only Original Equipment Manufacturer (O.E.M.) replacement parts.  
 Failure to do so could be hazardous, damage your snow thrower and void your warranty.

# REPAIR PARTS

DRIVE

SNOW THROWER - MODEL NO. **ST 324P** (96191008200), PRODUCT NO. 961 91 00-82

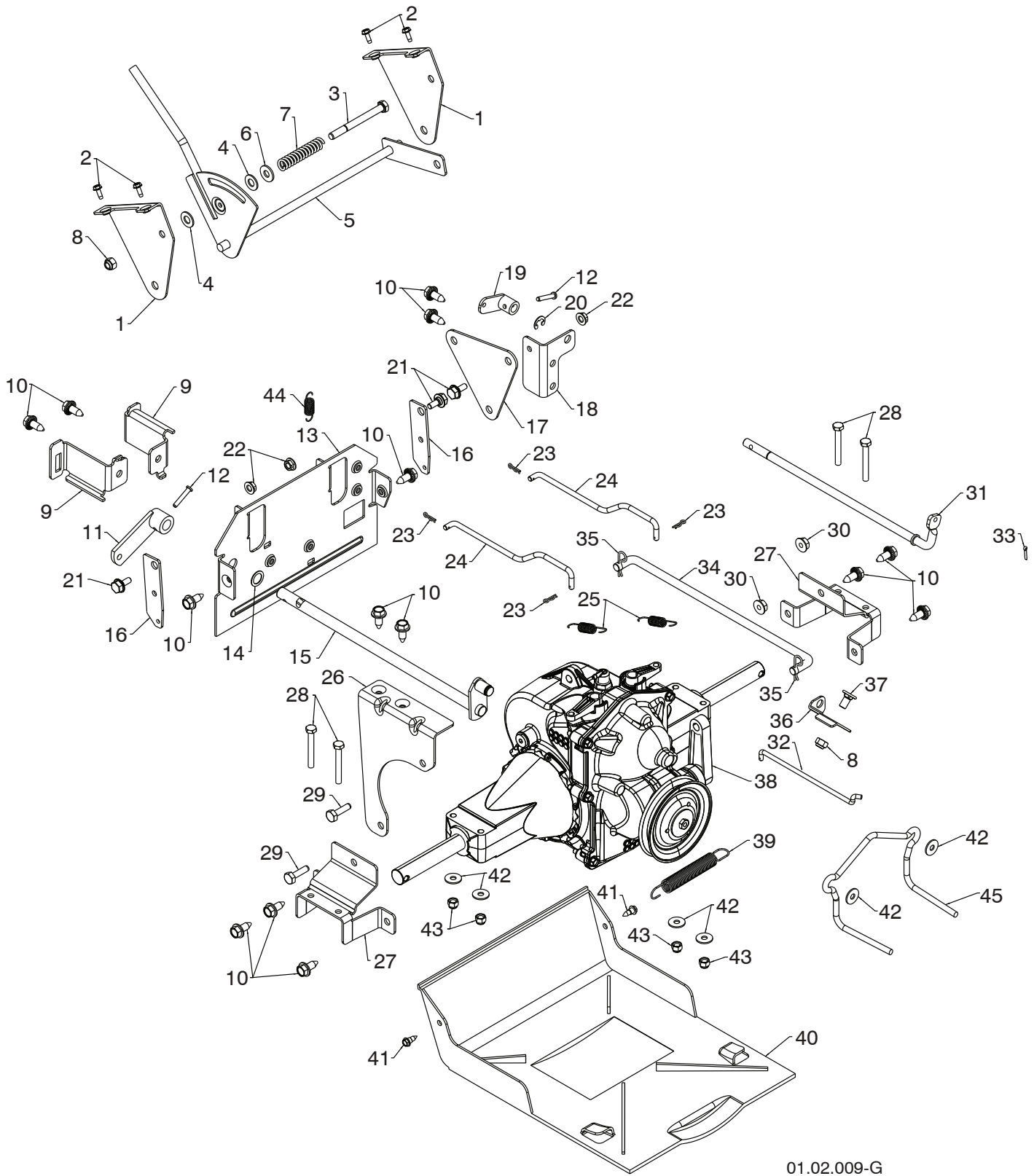

01.02.009-G

**NOTE:** All component dimensions given in U.S. inches. 1 inch = 25.4 mm  
**IMPORTANT:** Use only Original Equipment Manufacturer (O.E.M.) replacement parts.  
Failure to do so could be hazardous, damage your snow thrower and void your warranty.

**REPAIR PARTS****DRIVE****SNOW THROWER - MODEL NO. ST 324P (96191008200), PRODUCT NO. 961 91 00-82**

KEY NO.	PART NO.	DESCRIPTION	KEY NO.	PART NO.	DESCRIPTION
1	532 44 33-44	SHIFT BRACKET	23	532 06 53-22	HAIRPIN RETAINER SMALL
2	817 54 10-08	THREAD ROLLING SCREW 10-24 X .500	24	532 42 54-96	STEER ROD
3	874 76 05-52	SCREW 5/16-18 X 3.25	25	532 19 41-24	RETURN SPRING
4	532 17 92-46	PLASTIC WASHER	26	532 44 33-46	STABILIZER BRACKET
5	532 42 55-96	SHIFT ASSEMBLY	27	532 44 33-45	TRANSMISISON MOUNTING BRACKET
6	532 15 54-15	WASHER	28	874 88 04-32	SCREW 1/4-20 X 2.00
7	532 19 21-95	FRICTION SPRING	29	874 76 05-16	BOLT 5/16-18 X 1.00
8	873 80 05-00	NUT 5/16-18 LOCK	30	532 75 11-53	NUT 5/16-18 TOP LOCK
9	532 44 33-47	CABLE MOUNTING BRACKET RH	31	532 19 82-51	CLUTCH SHAFT
10	532 42 88-67	SCREW 5/16-18 X .750	32	532 44 62-93	CLUTCH ROD
11	532 40 54-85	CONTROL ARM	33	532 70 02-79	RETAINER CLIP
12	532 19 85-80	CLEVIS PIN	34	532 42 54-99	SPEED CONTROL ROD
13	532 43 71-51	REAR PLATE	35	532 16 96-75	HAIRPIN RETAINER LARGE
14	532 05 70-79	WASHER	36	532 42 98-03	FRONT CLUTCH BRACKET
15	532 42 75-42	CONTROL SHAFT	37	532 18 03-55	CARRIAGE BOLT 5/16-18 X .625
16	532 44 33-50	STEER LEVER	38	532 42 53-94	HYDROSTATIC TRANSMISSION
17	532 44 33-49	PIVOT PLATE	39	532 17 88-28	BRAKE SPRING
18	532 44 33-48	REAR CLUTCH BRACKET	40	532 42 54-98	BOTTOM PAN
19	532 19 82-49	CLUTCH ARM	41	532 18 44-71	SHOULDER SCREW 10-24
20	532 42 82-88	E-RING .375	42	532 05 38-47	WASHER
21	532 40 28-81	SHOULDER BOLT 1/4-20	43	873 80 04-00	NUT 1/4-20 NYLOCK
22	532 19 17-30	NUT 1/4-20 SIDELOCK	44	532 40 65-58	RETURN SPRING
			45	584 99 45-01	BELT GUIDE HYDRO 2

**NOTE:** All component dimensions given in U.S. inches. 1 inch = 25.4 mm**IMPORTANT:** Use only Original Equipment Manufacturer (O.E.M.) replacement parts. Failure to do so could be hazardous, damage your snow thrower and void your warranty.

# REPAIR PARTS

DRIVE

SNOW THROWER - MODEL NO. **ST 324P** (96191008200), PRODUCT NO. 961 91 00-82

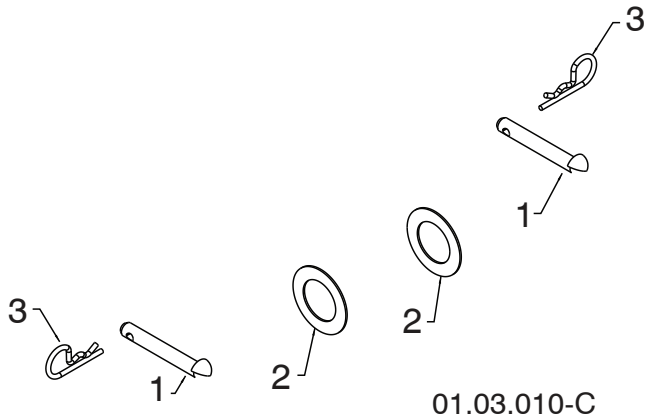

KEY NO.	PART NO.	DESCRIPTION
1	532 17 12-71	RIVET
2	532 12 49-31	THRUST WASHER
3	532 12 47-88	RETAINER

**NOTE:** All component dimensions given in U.S. inches. 1 inch = 25.4 mm  
**IMPORTANT:** Use only Original Equipment Manufacturer (O.E.M.) replacement parts.  
Failure to do so could be hazardous, damage your snow thrower and void your warranty.

# REPAIR PARTS

# CHASSIS / PULLEYS

SNOW THROWER - MODEL NO. **ST 324P** (96191008200), PRODUCT NO. 961 91 00-82

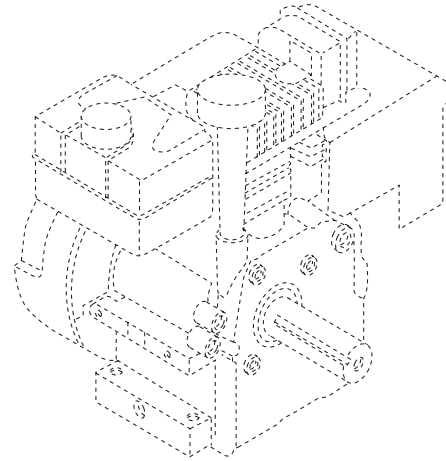
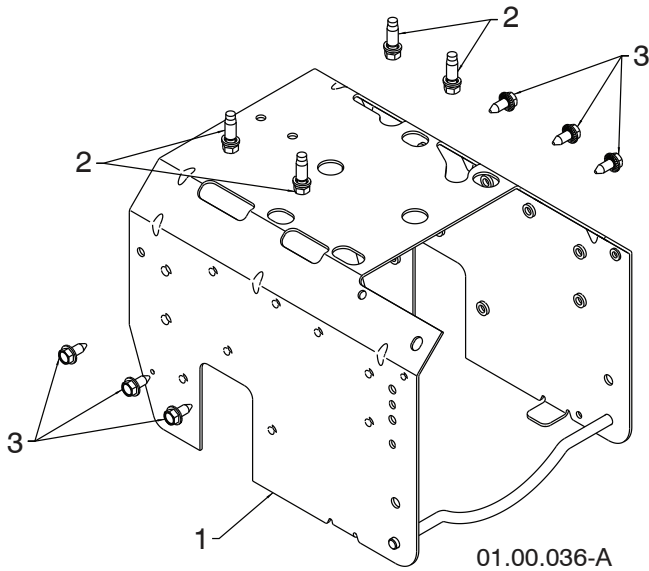

KEY NO.	PART NO.	DESCRIPTION
--	585 33 57-04	COMPLETE LCT ENGINE PW2HK18750178Y
1	586 50 78-03	FRAME
2	532 15 04-06	BOLT 3/8-16
3	532 42 88-67	SCREW 5/16-18 X .750

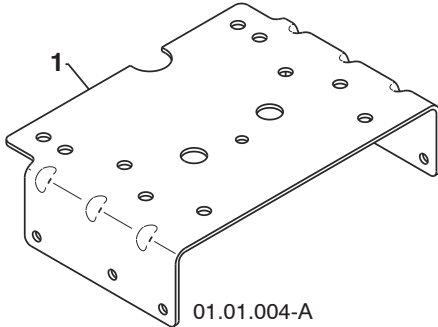

KEY NO.	PART NO.	DESCRIPTION
1	532 42 92-69	ENGINE MOUNTING PLATE

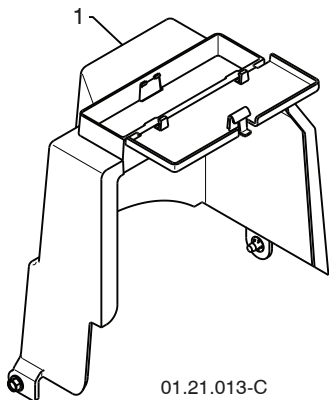

KEY NO.	PART NO.	DESCRIPTION
1	532 44 30-30	COVER ASSEMBLY

**NOTE:** All component dimensions given in U.S. inches. 1 inch = 25.4 mm  
**IMPORTANT:** Use only Original Equipment Manufacturer (O.E.M.) replacement parts. Failure to do so could be hazardous, damage your snow thrower and void your warranty.

# REPAIR PARTS

# CHASSIS / PULLEYS

SNOW THROWER - MODEL NO. **ST 324P** (96191008200), PRODUCT NO. 961 91 00-82

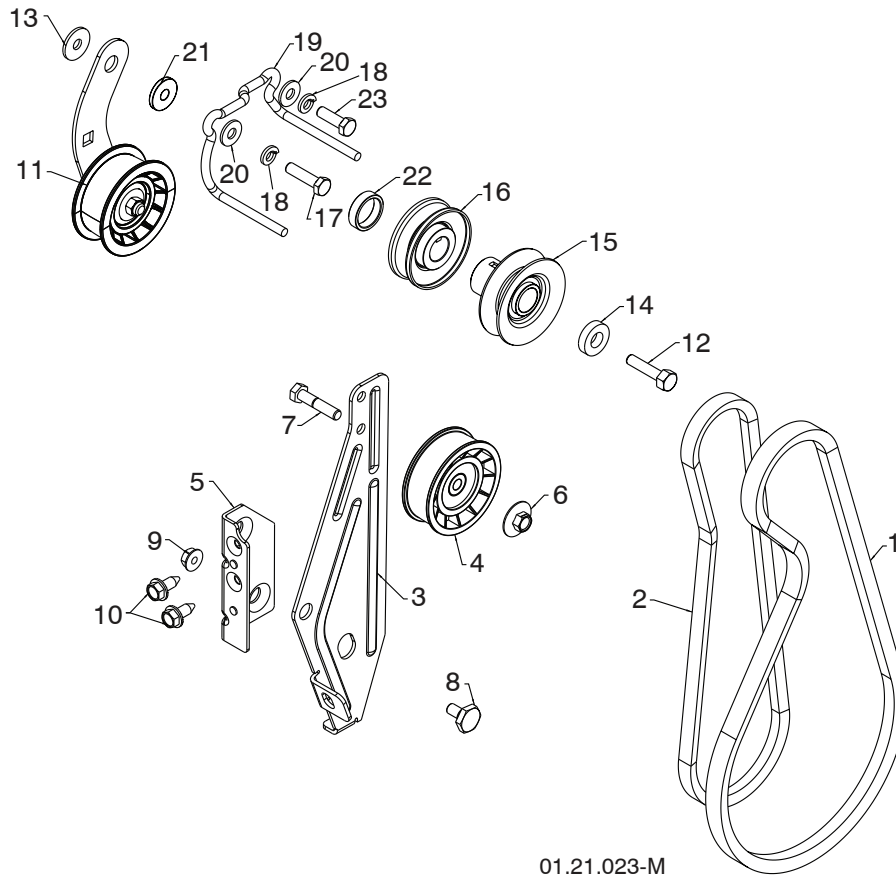

01.21.023-M

KEY NO.	PART NO.	DESCRIPTION	KEY NO.	PART NO.	DESCRIPTION
1	532 40 80-07	IMPELLER BELT	12	532 85 10-84	SCREW 3/8-24 X 1.375
2	532 44 81-83	TRACTION BELT	13	532 05 92-89	WASHER
3	584 23 24-02	IDLER ARM BRACKET	14	532 40 00-26	WASHER
4	532 18 05-23	IDLER PULLEY	15	532 42 64-91	PULLEY ENG IMPELLER
5	585 28 49-01	IDLER BRACKET	16	532 18 04-78	PULLEY ENG TRACTION
6	532 42 65-89	NUT 5/16-18	17	874 61 05-20	SCREW 5/16-24 X 1.25
7	874 78 05-24	SCREW 5/16-18 X 1.50	18	810 04 05-00	LOCKWASHER 5/16
8	532 42 42-97	SHOULDER BOLT 5/16-18 X .50	19	585 54 05-01	BELT GUIDE
9	532 75 11-53	NUT 5/16-18 LOCK	20	532 15 54-15	WASHER .20 X 8.5 X 2.0
10	817 00 05-10	SCREW 5/16-18 X 1.0 HEX WHS HD	21	532 17 53-31	IDLER BUSHING
11	585 23 84-01	TRACTION IDLER BRACKET ASM	22	532 40 94-75	SPACER
			23	874 61 05-16	SCREW 5/1-24 X 1.0 HEX

**NOTE:** All component dimensions given in U.S. inches. 1 inch = 25.4 mm  
**IMPORTANT:** Use only Original Equipment Manufacturer (O.E.M.) replacement parts.  
 Failure to do so could be hazardous, damage your snow thrower and void your warranty.



# REPAIR PARTS

# WHEELS

SNOW THROWER - MODEL NO. **ST 324P** (96191008200), PRODUCT NO. 961 91 00-82

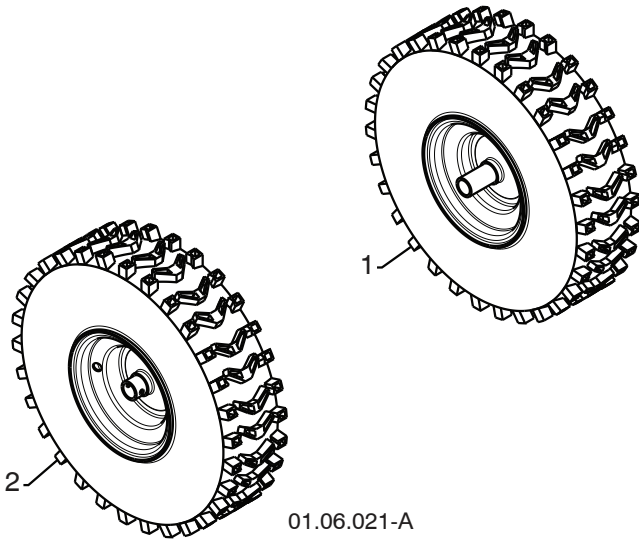

KEY NO.	PART NO.	DESCRIPTION
1	587 08 14-01	WHEEL ASSEMBLY LH
2	587 08 14-02	WHEEL ASSEMBLY RH

**NOTE:** All component dimensions given in U.S. inches. 1 inch = 25.4 mm  
**IMPORTANT:** Use only Original Equipment Manufacturer (O.E.M.) replacement parts.  
Failure to do so could be hazardous, damage your snow thrower and void your warranty.

# REPAIR PARTS

# BAG OF PARTS

SNOW THROWER - MODEL NO. **ST 324P** (96191008200), PRODUCT NO. 961 91 00-82

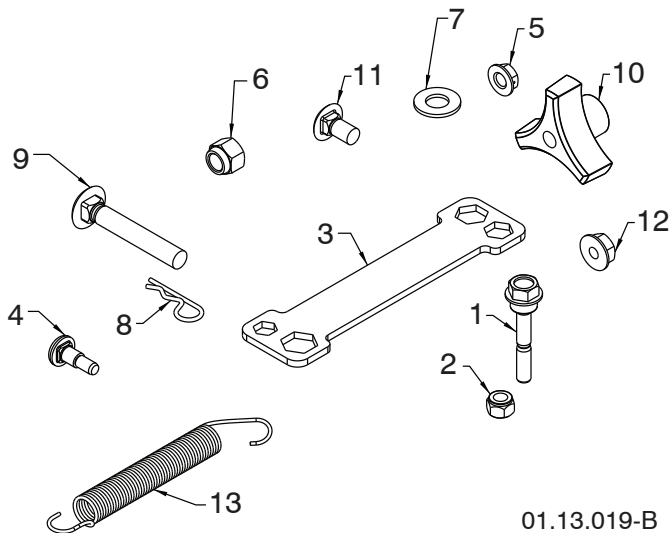

KEY NO.	PART NO.	DESCRIPTION
1	585 51 18-01	BOLT 1/4-20 X 1.81
2	873 80 04-00	NUT NYLOCK 1/4-20
3	532 42 91-12	WRENCH
4	532 17 98-29	BOLT SHOULDER
5	532 19 17-30	NUT HEX FL 1/4-20 CTR
6	873 80 06-00	NUT NYLOCK 3/8-16
7	819 13 13-16	WASHER FLAT 3/8 SAE
8	532 16 96-75	RETAINER HAIRPIN
9	872 12 06-18	BOLT 3/8-16 X 2.25
10	532 17 88-99	KNOB 3/8-16 TRI LOBE
11	585 83 20-01	BOLT BLACK 5/16-18 X 5/8
12	532 75 11-53	NUT FL LOCK 5/16-18
13	532 18 45-05	SPRING DEFLECT CHUTE
NI	532 40 97-80	SHEAR BOLT KIT

01.13.019-B

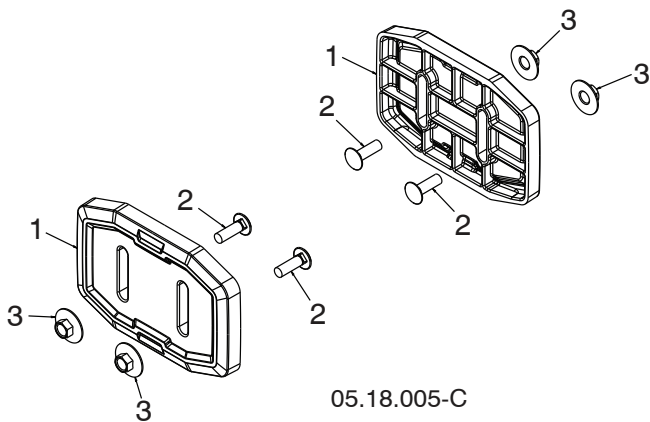

KEY NO.	PART NO.	DESCRIPTION
1	583 83 88-01	SKID PLATE UHMW
2	532 43 73-18	BOLT CARRIAGE 5/16-18 X 1.00 - BLK
3	585 80 28-01	NUT LRG FLANGE LOCK 5/16-18 - BLK

05.18.005-C

**NOTE:** All component dimensions given in U.S. inches. 1 inch = 25.4 mm  
**IMPORTANT:** Use only Original Equipment Manufacturer (O.E.M.) replacement parts. Failure to do so could be hazardous, damage your snow thrower and void your warranty.

# REPAIR PARTS

# BAG OF PARTS

SNOW THROWER - MODEL NO. **ST 324P** (96191008200), PRODUCT NO. 961 91 00-82

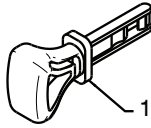

01.14.009-B

KEY NO.	PART NO.	DESCRIPTION
1	532 44 30-59	SAFETY IGNITION KEY KIT

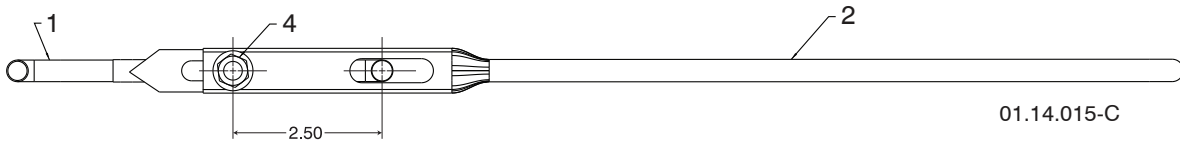
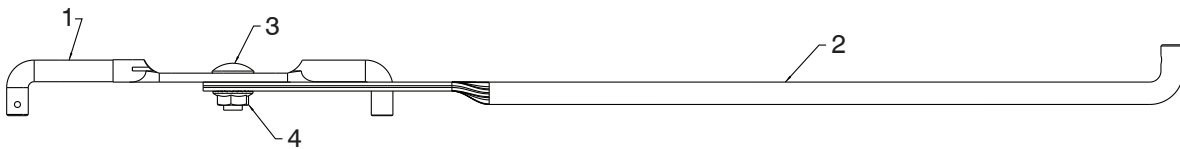

01.14.015-C

KEY NO.	PART NO.	DESCRIPTION
1	532 42 55-98	SHIFTER ROD TOP
2	532 18 77-84	SHIFTER ROD BOTTOM
3	872 27 05-05	CARRIAGE BOLT 5/16-18 X .75
4	532 15 53-77	NUT 5/16-18

**NOTE:** All component dimensions given in U.S. inches. 1 inch = 25.4 mm  
**IMPORTANT:** Use only Original Equipment Manufacturer (O.E.M.) replacement parts. Failure to do so could be hazardous, damage your snow thrower and void your warranty.

# REPAIR PARTS

# DECALS

SNOW THROWER - MODEL NO. **ST 324P** (96191008200), PRODUCT NO. 961 91 00-82

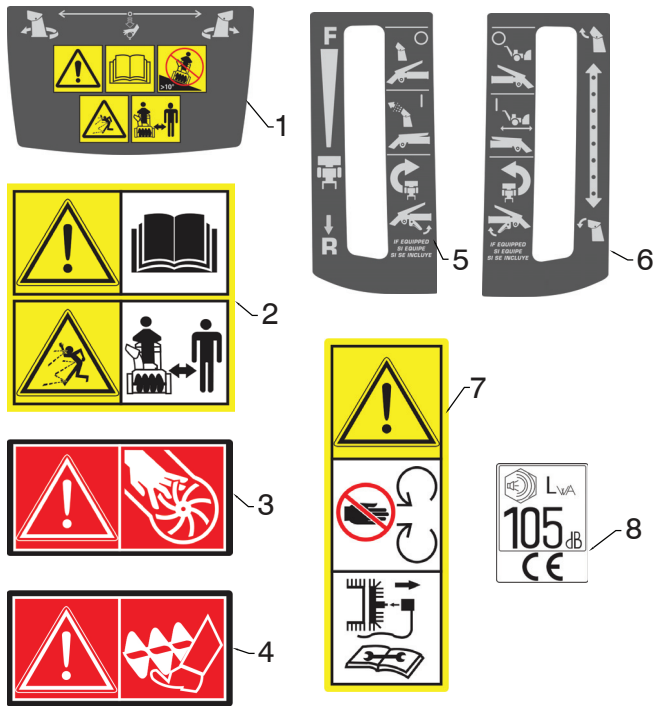

KEY NO.	PART NO.	DESCRIPTION
1	532 42 95-75	DECAL CONSOLE INSTRUCTIONS
2	532 18 40-45	DECAL AUGER
3	532 19 96-82	DECAL CHUTE
4	532 19 96-83	DECAL AUGER SAFETY
5	585 76 87-01	DECAL CONSOLE RH INSTRUCTIONS
6	585 76 87-02	DECAL CONSOLE LH INSTRUCTIONS
7	532 18 40-28	DECAL BELT GUARD
8	532 18 04-33	DECAL NOISE LEVEL

05.16.004-A

**NOTE:** All component dimensions given in U.S. inches. 1 inch = 25.4 mm  
**IMPORTANT:** Use only Original Equipment Manufacturer (O.E.M.) replacement parts.  
 Failure to do so could be hazardous, damage your snow thrower and void your warranty.

# REPAIR PARTS

# DECALS

SNOW THROWER - MODEL NO. **ST 324P** (96191008200), PRODUCT NO. 961 91 00-82

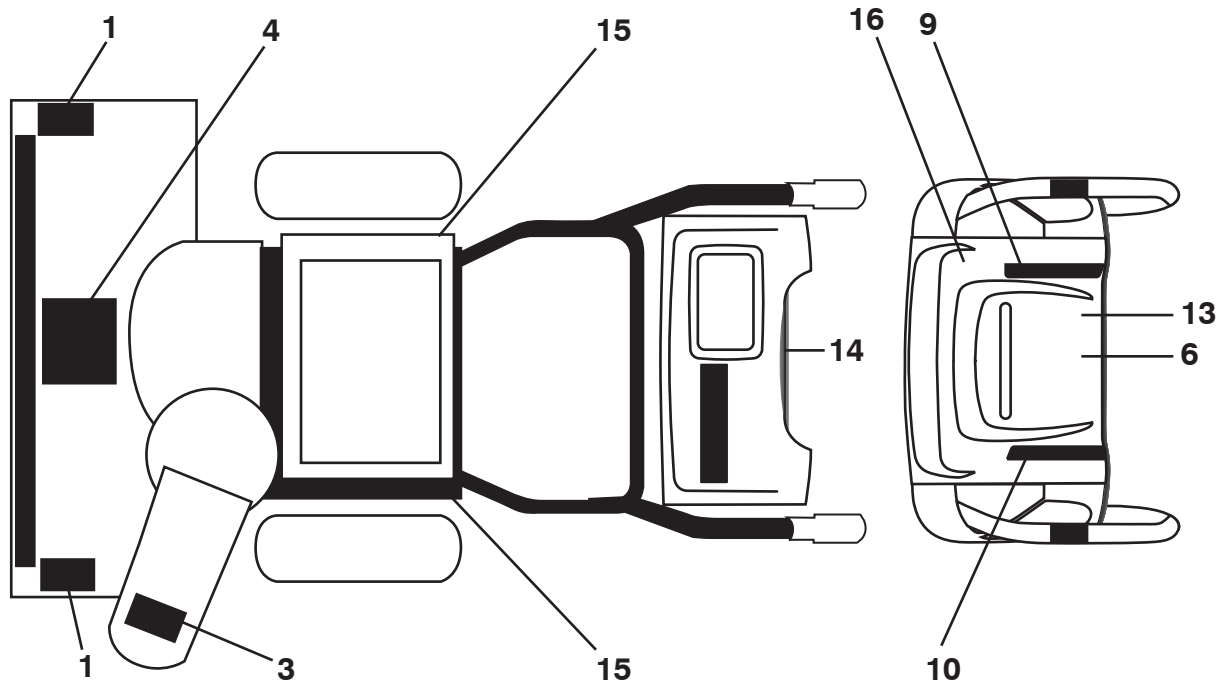

KEY NO.	PART NO.	DESCRIPTION
1	532 19 96-83	DECAL, DANGER
3	532 19 96-82	DECAL, DANGER, DEFLECTOR
4	532 18 40-45	DECAL, DANGER
6	532 42 95-75	DECAL, INSTRUCTION
9	585 76 87-01	DECAL, CONS RT
10	585 76 87-02	DECAL, CONS LT
13	532 44 47-68	DECAL
14	585 76 87-02	DECAL, SOUND LEVEL
15	532 18 40-28	DECAL, BELT GUARD
16	532 44 47-68	DECAL, HANDWARMER
--	115 68 59-20	OPERATOR'S MANUAL, EUROPEAN
--	115 68 59-10	OPERATOR'S MANUAL, SCANDINAVIAN
--	115 68 59-50	OPERATOR'S MANUAL, EAST BLOC
--	115 68 59-40	OPERATOR'S MANUAL, BALTIC

**NOTE:** All component dimensions given in U.S. inches. 1 inch = 25.4 mm

**IMPORTANT:** Use only Original Equipment Manufacturer (O.E.M.) replacement parts. Failure to do so could be hazardous, damage your snow thrower and void your warranty.

# REPAIR PARTS

## COMPLETE LCT ENGINE - 585335704

GEN II 136/179/208/254cc Snow Engines

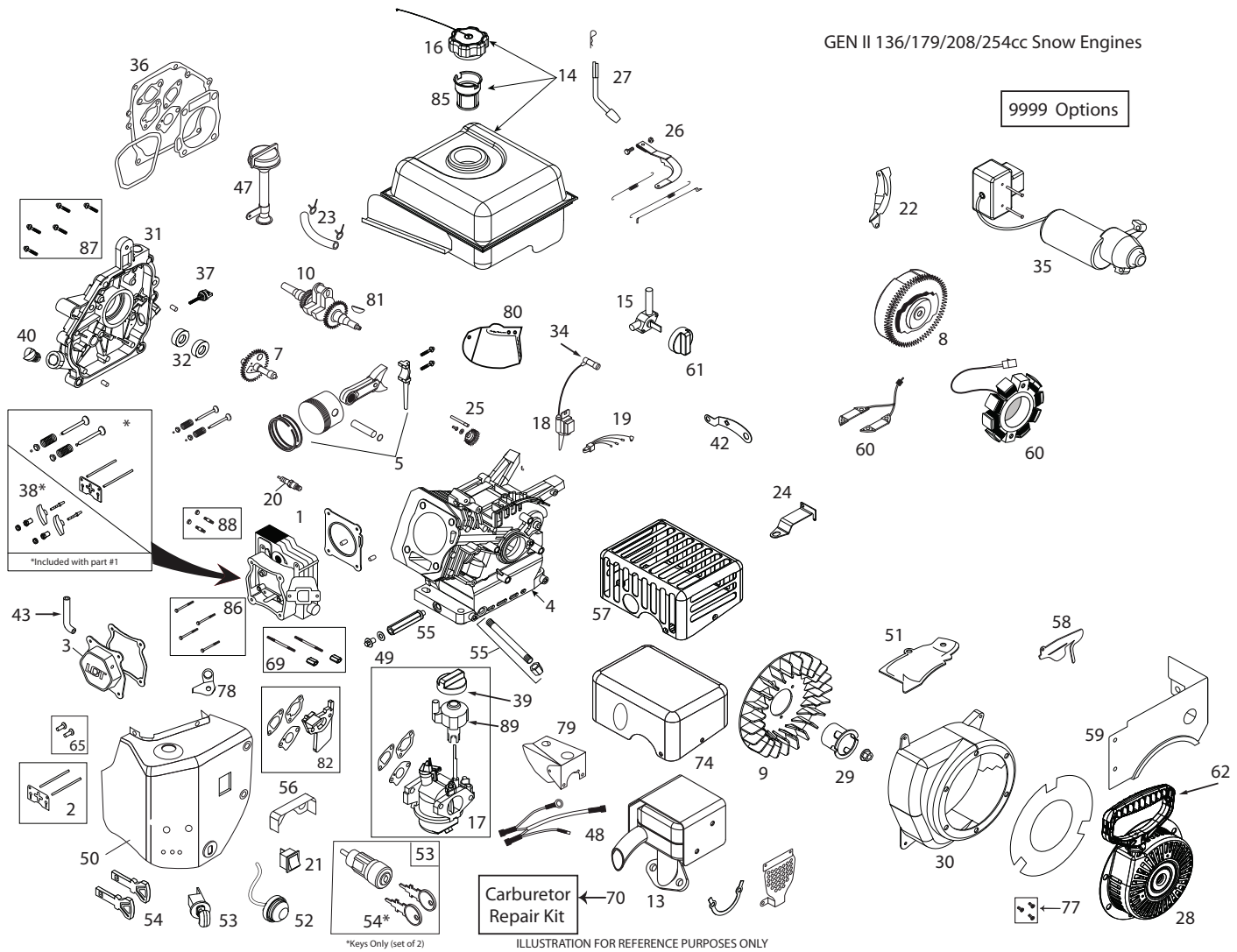

KEY NO.	PART NO.	DESCRIPTION	KEY NO.	PART NO.	DESCRIPTION
1	585 77 14-01	CYLINDER HEAD ASSEMBLY - 254CC (INCL. GASKET)	10	587 15 39-01	CRANKSHAFT (#18 KEYED 254CC SNOW)
2	585 77 15-01	PUSH ROD & PLATE KIT (254CC) (INCL. VALVE COVER GSKT)	13	585 77 21-01	MUFFLER ASSEMBLY-GEN LL SNOW (254CC)
3	585 77 16-01	VALVE COVER (254CC) (INCL. GASKET)	14	587 15 40-01	FUEL TANK (2.7L GLOSS BLACK) (254CC SNOW)(ORDER DECAL KIT SEPARATE)
4	587 15 38-01	CYLINDER - 254CC (FRONT OIL DRAIN)	15	532 42 92-34	FUEL TANK ON/OFF VALVE - GEN II SNOW
5	585 77 17-01	PISTON & ROD ASSEMBLY (254CC)	16	532 42 49-42	FUEL TANK CAP - BLACK CLICK STYLE (VENTED)
7	585 77 18-01	CAMSHAFT - MCR (254CC)	17	587 15 41-01	CARBURETOR (L15D) (254CC SNOW W/IDLE-DOWN CONTROL) (W/GSKTS)
8	585 77 19-01	FLYWHEEL - ELECTRIC START (8-CHARGING MAGNETS) (254CC)	18	532 44 38-94	IGNITION COIL (CDI) (208/254CC) (HI-TEMP)
9	532 42 05-86	COOLLNG FAN - FLYWHEEL (PLASTIC - 208CC)			

**NOTE:** All component dimensions given in U.S. inches. 1 inch = 25.4 mm  
**IMPORTANT:** Use only Original Equipment Manufacturer (O.E.M.) replacement parts. Failure to do so could be hazardous, damage your snow thrower and void your warranty.

# REPAIR PARTS

## COMPLETE LCT ENGINE - 585335704

KEY NO.	PART NO.	DESCRIPTION	KEY NO.	PART NO.	DESCRIPTION
20	532 44 38-98	SPARK PLUG - PLATINUM	52	532 42 49-49	PRIMER BULB WITH HOSE-SNOW
21	532 42 49-57	ON/OFF SWITCH - ROCKER	53	532 42 49-54	KEY SWITCH - SAFETY (PUSH/PULL) SNOW (INCL. KEYS)
22	585 77 24-01	SHIELD - FLYWHEEL (ELECTRIC 208CC)	54	532 44 30-59	KEY SET - RED (2) (SNOW)
23	532 43 21-44	FUEL HOSE -1/4 (318MM)(CUT TO 240MM)	55	587 15 44-01	FRONT OIL DRAIN PIPE & NUT ASSY
24	585 77 25-01	SPEED CONTROL BRACKET (FIXED)(254CC SNOW)	56	585 77 33-01	CARBURETOR VAPOR SHIELD (254CCSNOW)
25	532 42 96-46	GOVERNOR GEAR ASSEMBLY (136/208CC)	57	532 43 66-72	CE COMPLIANT MUFFLER SHIELD
26	585 77 26-01	GOVERNOR ARM & LINK KIT (254CC SNOW)	58	585 77 34-01	SHIELD - GOVERNOR LINKAGE (254CC-SNOW)
27	532 42 06-02	GOVERNOR ARM PADDLE	59	587 15 45-01	FUEL TANK SKIRT SHIELD (GLOSS BLACK-254CC)(ORDER DECAL KIT SEPARATE)
28	532 43 69-67	RECOIL STARTER (ROUND STYLE-BLACK) 136/208CC GEN II SNOW	60	532 44 38-93	CHARGING COIL (60-WATT AC) (208/254CC)
29	532 43 69-68	STARTER CUP (USE WITH ROUND STYLE STARTER) (208CC SNOW)	61	532 43 27-52	FUEL CONTROL KNOB (GEN II SNOW - RED)
30	587 15 42-01	BLOWER HOUSING (GLOSS BLACK)(254CC SNOW W/FRONT DRAIN)(ORDER DECAL KIT SEPARATE)	62	532 44 38-99	STARTER GRIP-SNOW (DELUXE)
31	585 77 27-01	CRANKCASE COVER (PRESS-IN TYPE HIGH OIL-FILL TUBE)	65	581 37 28-01	TAPPET KIT (208/254CC)(SET OF 2)
32	585 77 28-01	OIL SEAL KIT (2 PCS)	69	532 42 49-51	CARBURETOR STUDS & COUPLING KIT-SNOW
34	532 43 69-66	SPARK PLUG BOOT - WITH METAL SHIELD (SNOW)	70	580 35 36-01	CARBURETOR REPAIR KIT (136/208/254CC)
35	532 43 66-71	230V EU ELECTRIC STARTER (208/254CC GEN II) (MOUNTING BOLTS ON SIDE OF BLOCK)	74	581 76 88-01	MUFFLER HEAT SHIELD COVER (136/208/254)
36	585 77 29-01	ENGINE GASKET KIT (254CC)	77	532 43 26-88	RECOIL BOLT KIT (INCL. (3) MTG BOLTS)
38	585 77 30-01	ROCKER ARM KIT (254CC)(INCL. GASKET)	79	585 77 37-01	CARBURETOR COVER (136/208/254CC SNOW)
39	532 42 92-24	CHOKE CONTROL KNOB (GEN II RED)	80	585 77 38-01	SHIELD GOVERNOR LINK - 254CC SNOW
40	532 42 95-98	NON-REMOVABLE PLASTIC PLUG (136/208/254CC)	81	585 29 72-02	WOODRUFF FLYWHEEL KEYS (5-PACK) (5X6X18MM)
43	580 35 34-01	BREATHER TUBE (136/208/254CC)	82	585 02 05-03	CARBURETOR SPACER (208/254CC)
47	581 00 72-01	HIGH OIL-FILL TUBE/DIPS-TICK (PRESS-IN TYPE) (SN >1265H0519257)	85	583 02 56-01	FUEL TANK STRAINER
48	532 42 92-62	WIRE HARNESS (208CC SNOW)	86	586 32 73-01	CYLINDER HEAD BOLT KIT (4) (136-179-208-254CC)
49	532 43 54-95	OIL DRAIN PLUG W/WASHER (136/208/254CC)	87	586 32 69-01	CC COVER BOLT KIT (6) (179-208-254CC)
50	587 15 43-01	HEATER BOX ASSEMBLY (GLOSS BLACK-254CC)(ORDER DECAL KIT SEPARATE)	88	586 32 68-01	MUFFLER MTG STUD KIT (2)
			89	587 12 48-01	SPEED CONTROL KNOB, GEN II, SNOW
			9999	587 15 48-01	HIGH ALTITUDE JET (>5,000 FEET)(254CC L15 CARBURETOR)

**NOTE:** All component dimensions given in U.S. inches. 1 inch = 25.4 mm

**IMPORTANT:** Use only Original Equipment Manufacturer (O.E.M.) replacement parts. Failure to do so could be hazardous, damage your snow thrower and void your warranty.

