

ILLUSTRATED PARTS LIST

MODEL NUMBER ST 227P

PRODUCT NUMBER 961 91 00-88

MFG. ID. NUMBER 96191008800

REPAIR PARTS

AUGER HOUSING / IMPELLER ASSEMBLY

SNOW THROWER - MODEL NO. ST 227P (96191008800), PRODUCT NO. 961 91 00-88

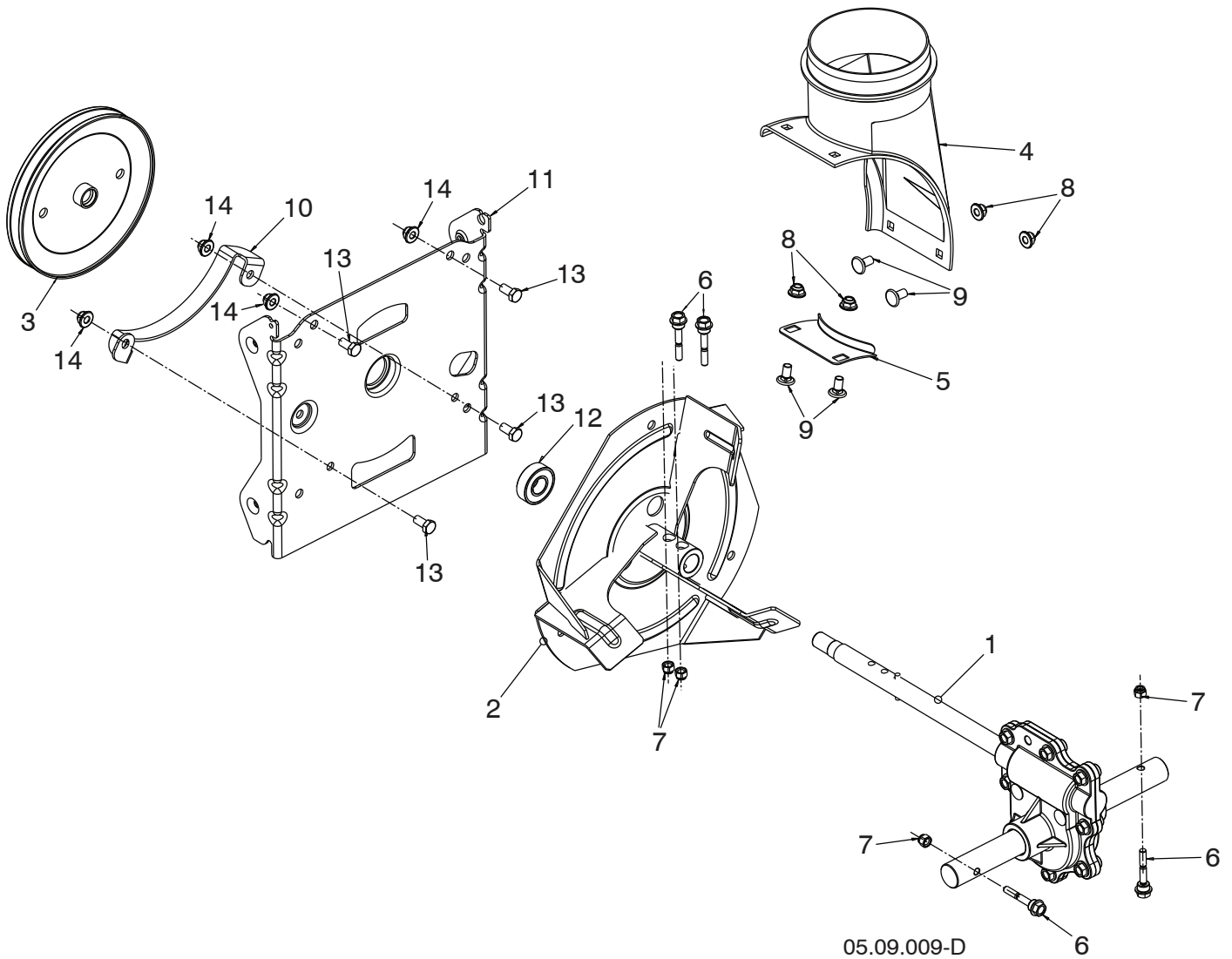

NOTE: All component dimensions given in U.S. inches. 1 inch = 25.4 mm
IMPORTANT: Use only Original Equipment Manufacturer (O.E.M.) replacement parts.
Failure to do so could be hazardous, damage your snow thrower and void your warranty.

REPAIR PARTS**AUGER HOUSING / IMPELLER ASSEMBLY****SNOW THROWER - MODEL NO. ST 227P (96191008800), PRODUCT NO. 961 91 00-88**

KEY NO.	PART NO.	DESCRIPTION
1	586 71 48-01	GEARBOX AUGER
2	586 60 72-02	IMPELLER STEEL
3	586 71 52-01	PULLEY IMPELLER SCREW ON
4	585 05 69-01	CHUTE DISCHARGE BASE
5	532 18 40-95	BRACKET CORNER DISCHARGE BASE
6	585 51 18-01	BOLT SHEAR 1/4-20
7	873 80 04-00	NUT NYLOCK 1/4-20
8	585 69 13-01	NUT FLANGE NYLOCK 5/16-18 - BLK
9	585 69 12-01	BOLT CARRIAGE WAFER HEAD 5/16-18 X 5/8 BLK
10	581 63 20-02	BRACKET BELT KEEPER LOWER
11	581 59 25-02	BRACKET INTERFACE
12	532 19 87-91	BEARING BALL
13	532 16 31-83	SCREW HEX HEAD 5/16-18 X 5/8
14	532 42 79-42	NUT FLANGE NYLOCK 5/16-18

NOTE: All component dimensions given in U.S. inches. 1 inch = 25.4 mm
IMPORTANT: Use only Original Equipment Manufacturer (O.E.M.) replacement parts.
Failure to do so could be hazardous, damage your snow thrower and void your warranty.

REPAIR PARTS

AUGER HOUSING / IMPELLER ASSEMBLY

SNOW THROWER - MODEL NO. ST 227P (96191008800), PRODUCT NO. 961 91 00-88

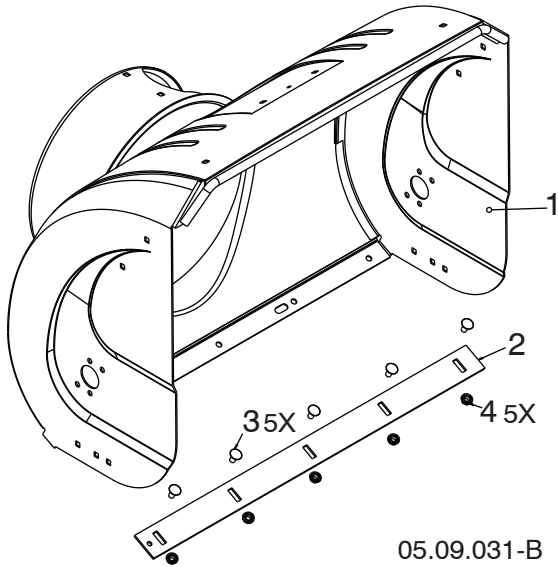

KEY NO.	PART NO.	DESCRIPTION
1	586 18 40-05	AUGER HOUSING
2	532 40 77-27	SCRAPER BAR
3	872 27 05-05	CARRIAGE BOLT 5/16-18 X .625 GR5
4	532 15 53-77	NUT 5/16-18

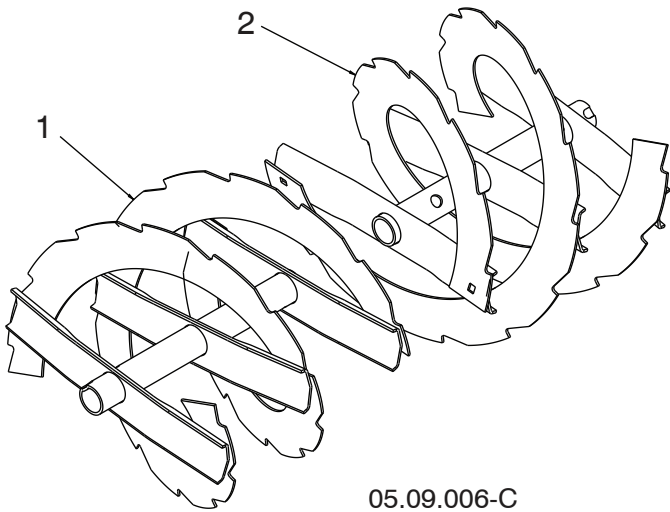

KEY NO.	PART NO.	DESCRIPTION
1	532 43 62-55	AUGER 27 LH
2	532 43 62-56	AUGER 27 RH

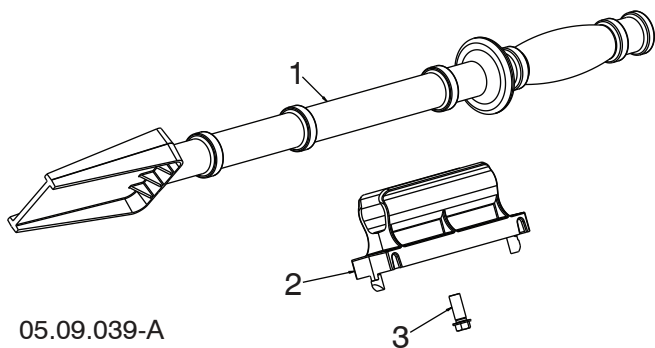

KEY NO.	PART NO.	DESCRIPTION
1	532 19 21-99	TOOL CLEANOUT
2	532 40 54-00	CLIP CLEANOUT TOOL
3	532 19 41-89	SCREW HEX WASHER 13-16 X 5/8

NOTE: All component dimensions given in U.S. inches. 1 inch = 25.4 mm
IMPORTANT: Use only Original Equipment Manufacturer (O.E.M.) replacement parts. Failure to do so could be hazardous, damage your snow thrower and void your warranty.

REPAIR PARTS

AUGER HOUSING / IMPELLER ASSEMBLY

SNOW THROWER - MODEL NO. ST 227P (96191008800), PRODUCT NO. 961 91 00-88

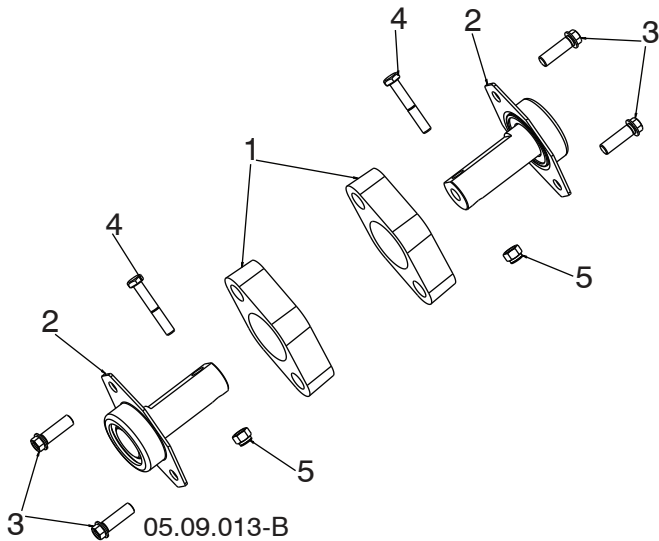

KEY NO.	PART NO.	DESCRIPTION
1	532 18 81-70	PLASTIC RETAINER
2	532 42 77-62	AUGER BALL BEARING
3	584 29 94-01	SCREW HI-LO 5/16-14 X 1.00 - BLK
4	874 78 04-26	SCREW 1/4-20 X .625
5	873 80 04-00	NUT 1/4-20

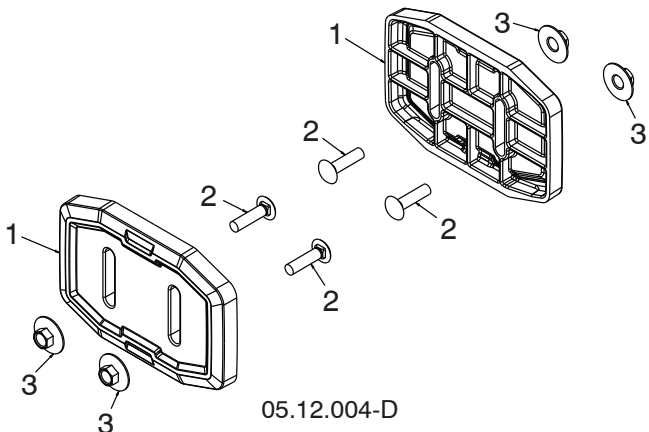

KEY NO.	PART NO.	DESCRIPTION
1	583 83 88-01	SKID SHOW UHMW
2	585 80 29-01	BOLT CARR BLK 5/16-18 X 1.25
3	585 80 28-01	NUT HEX 5/16-18 LRG FLG

NOTE: All component dimensions given in U.S. inches. 1 inch = 25.4 mm
IMPORTANT: Use only Original Equipment Manufacturer (O.E.M.) replacement parts.
 Failure to do so could be hazardous, damage your snow thrower and void your warranty.

REPAIR PARTS

CONTROL PANEL / DISCHARGE CHUTE

SNOW THROWER - MODEL NO. ST 227P (96191008800), PRODUCT NO. 961 91 00-88

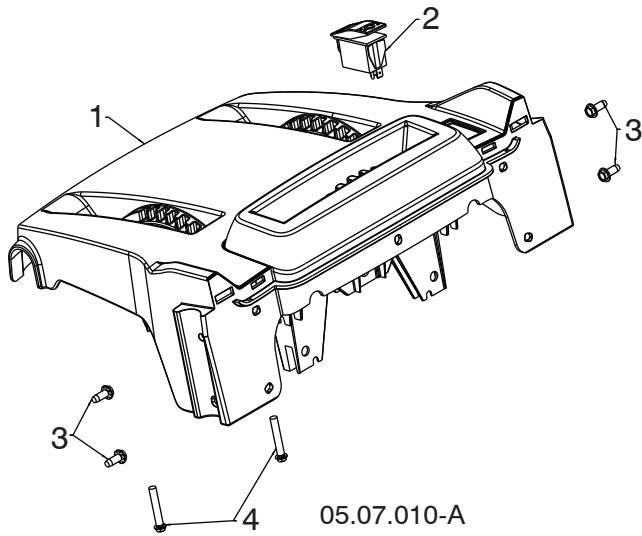

05.07.010-A

KEY NO.	PART NO.	DESCRIPTION
1	581 13 12-04	CONSOLE BASE MULTICONT GRAY-MS498
2	585 80 50-01	SWITCH GRIP HEATED BLACK
3	817 06 04-10	SCREW TA SEMI GIMLE 1/4-20 X .62
4	581 32 95-01	SCREW HEX WASHER HI-LO 13-16 X 1.50

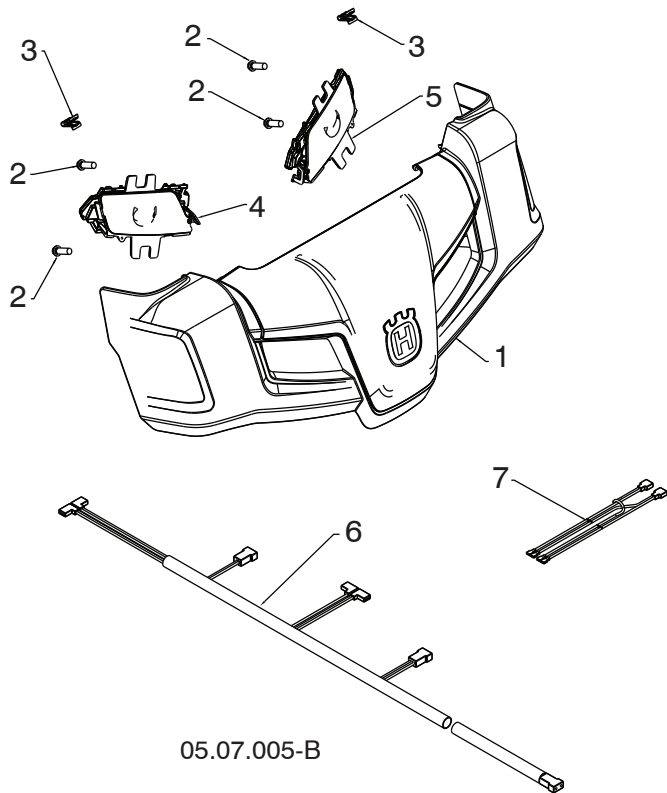

05.07.005-B

KEY NO.	PART NO.	DESCRIPTION
1	581 12 79-01	HUSQVARNA CONSOLE COVER ASM
2	532 19 41-89	SCREW HI-LO 13-16 X 5/6
3	581 92 87--01	CLIP PANEL
4	586 72 35-01	LIGHT ASM LED HUSQ RH
5	586 72 36-01	LIGHT ASM LED HUSQ LH
6	584 29 02-01	WIRE HARNESS LIGHT & GRIP
7	585 86 83-01	WIRE HARNESS LIGHT JUMPER

NOTE: All component dimensions given in U.S. inches. 1 inch = 25.4 mm
IMPORTANT: Use only Original Equipment Manufacturer (O.E.M.) replacement parts. Failure to do so could be hazardous, damage your snow thrower and void your warranty.

REPAIR PARTS

CONTROL PANEL / DISCHARGE CHUTE

SNOW THROWER - MODEL NO. ST 227P (96191008800), PRODUCT NO. 961 91 00-88

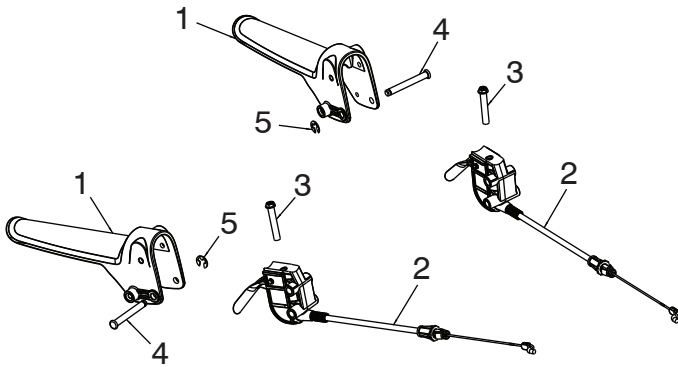

05.08.007-A

KEY NO.	PART NO.	DESCRIPTION
1	580 78 48-01	LEVER CONTROL DSSST OPP MPP
2	581 20 82-01	CONTROL UNIT ASM LEVER PIVOT
3	585 69 07-01	SCREW HEXHD 10-24 X 1.50
4	532 43 17-62	GROOVED PIN
5	812 00 00-14	E-RING EXTERNAL

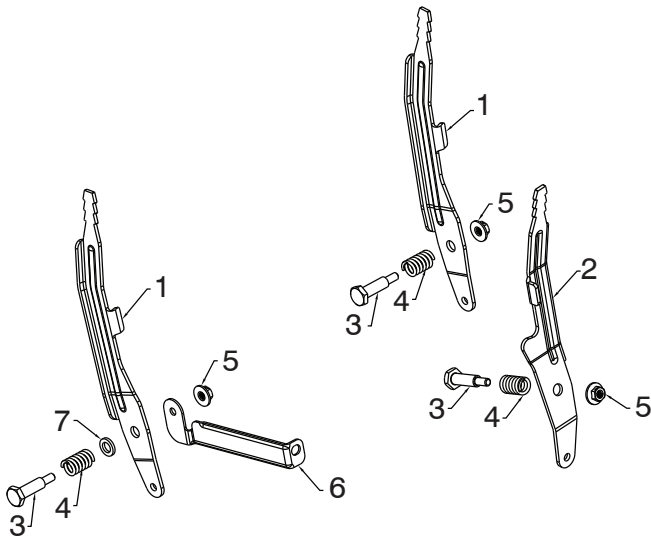

05.08.005-C

KEY NO.	PART NO.	DESCRIPTION
1	581 12 39-02	LEVER CONTROL SPEED/DEFL
2	581 24 16-02	LEVER CONTROL CHUTE ROT
3	581 32 97-01	BOLT SHOULDER 1/4-20
4	581 32 96-01	SPRING COMPRESSION
5	586 66 89-01	NUT FL LOCK 1/4-20
6	584 46 84-02	BRACE SUPPORT SPEED
7	587 03 13-01	WASHER .625 X .375 X .094 NYLON 6/6

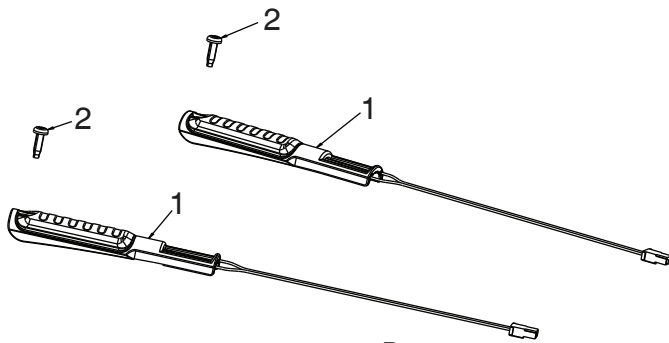

05.08.008-B

KEY NO.	PART NO.	DESCRIPTION
1	581 14 63-01	GRIP HANDLE HEATED
2	532 44 22-50	SCREW PAN HD TORX 1/4-20 X .75

NOTE: All component dimensions given in U.S. inches. 1 inch = 25.4 mm
IMPORTANT: Use only Original Equipment Manufacturer (O.E.M.) replacement parts. Failure to do so could be hazardous, damage your snow thrower and void your warranty.

REPAIR PARTS

CONTROL PANEL / DISCHARGE CHUTE

SNOW THROWER - MODEL NO. ST 227P (96191008800), PRODUCT NO. 961 91 00-88

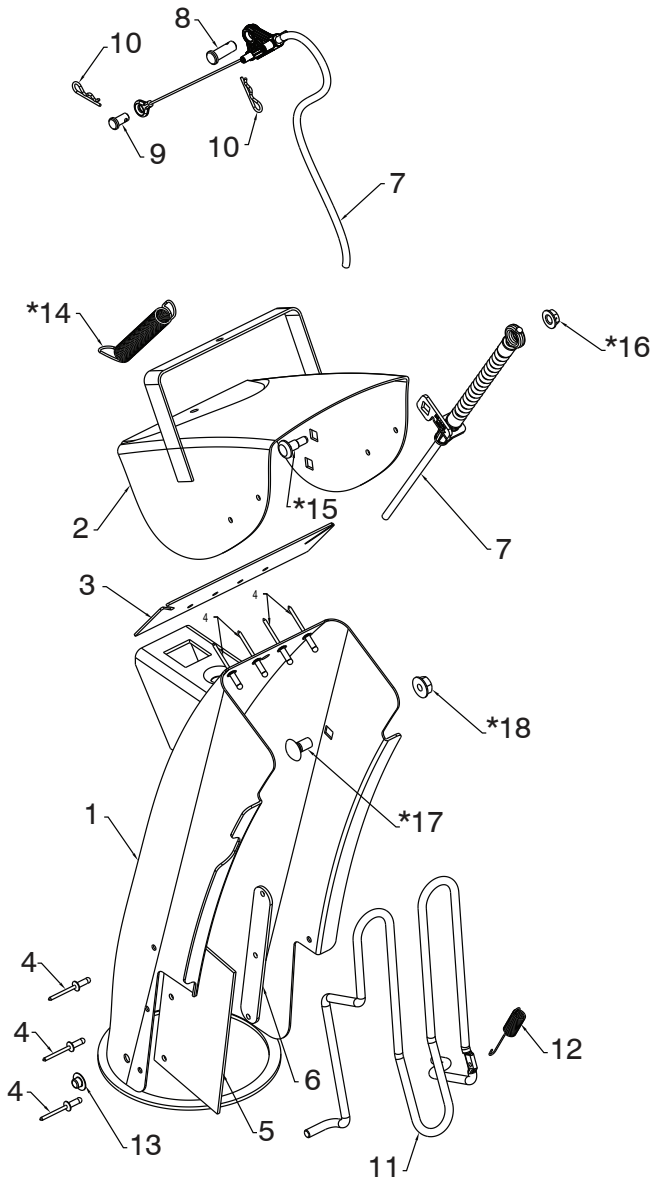

05.11.008-C

KEY NO.	PART NO.	DESCRIPTION
1	532 44 40-41	CHUTE WELDMENT
2	532 18 41-13	DEFLECTOR WELDMENT
3	532 42 03-25	DEFLECTOR SEAL
4	532 12 84-15	POP RIVET
5	532 43 03-24	CHUTE SNOW SHIELD
6	532 42 17-28	SHIELD STRAP RETAINER
7	586 96 15-01	CABLE ASM DEFLECTOR - BOWDEN
8	581 32 94-01	PIN CLEVIS 5/16 X .875
9	585 80 83-01	PIN CLEVIS 1/4 X .312
10	532 42 33-03	HAIRPIN RETAINER
11	532 43 55-82	CHUTE GUARD
12	532 43 56-16	GUARD RETURN SPRING
13	532 05 93-49	PUSH NUT
*14	532 18 45-05	DEFLECTOR SPRIN
*15	585 83 22-01	SHOULDER BOLT 1/4-20 X .375
*16	585 69 14-01	NUT 1/4-20
*17	585 83 20-01	CARRIAGE BOLT 3/8-16 X .625
*18	585 69 15-01	NUT 5/16-18

NOTE: ALL ITEMS MARKED WITH AN * ARE PROVIDED IN THE BAG OF ITEMS SHIPPED LOOSE WITH THE PRODUCT

NOTE: All component dimensions given in U.S. inches. 1 inch = 25.4 mm
IMPORTANT: Use only Original Equipment Manufacturer (O.E.M.) replacement parts. Failure to do so could be hazardous, damage your snow thrower and void your warranty.

REPAIR PARTS

CONTROL PANEL / DISCHARGE CHUTE

SNOW THROWER - MODEL NO. ST 227P (96191008800), PRODUCT NO. 961 91 00-88

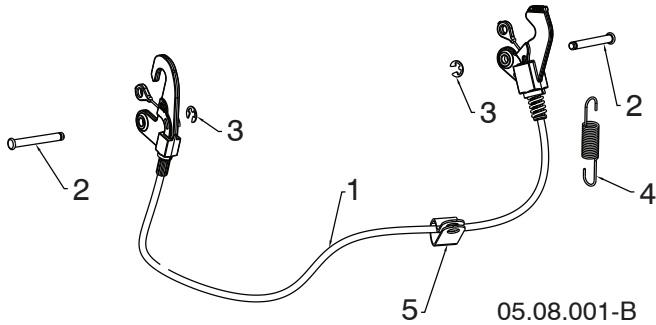

KEY NO.	PART NO.	DESCRIPTION
1	580 66 47-01	CABLE INTERLOCK
2	532 43 17-62	PIN GROOVED
3	812 00 00-14	E-RING
4	581 15 12-01	SPRING RETURN
5	532 19 79-91	CLIP CABLE BLACK

NOTE: All component dimensions given in U.S. inches. 1 inch = 25.4 mm
IMPORTANT: Use only Original Equipment Manufacturer (O.E.M.) replacement parts.
Failure to do so could be hazardous, damage your snow thrower and void your warranty.

REPAIR PARTS

CONTROL PANEL / DISCHARGE CHUTE

SNOW THROWER - MODEL NO. ST 227P (96191008800), PRODUCT NO. 961 91 00-88

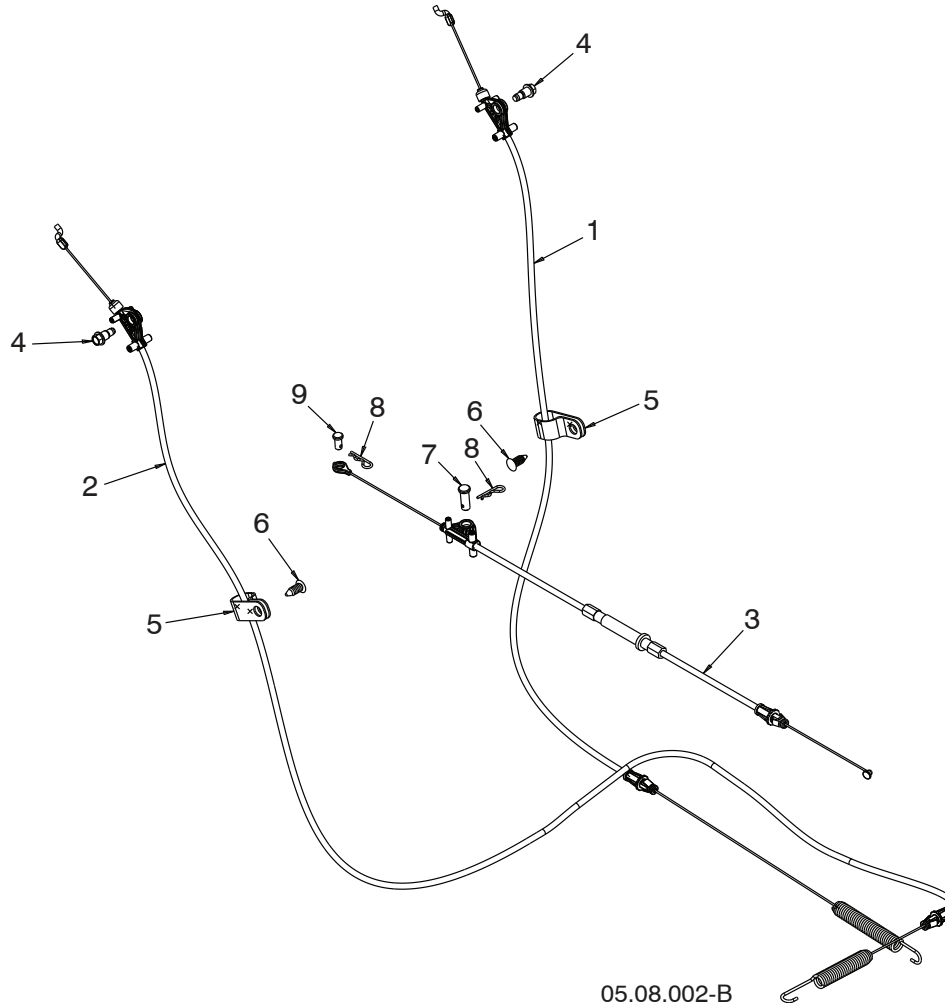

05.08.002-B

KEY NO.	PART NO.	DESCRIPTION
1	581 12 83-01	CABLE CONTROL DRIVE
2	581 12 82-01	CABLE CONTROL AUGER
3	581 12 42-01	CABLE CONTROL SPEED
4	581 72 61-01	BOLT SHOULDER 1/4
5	532 19 79-91	CLIP CABLE
6	532 42 81-24	FASTENER PUSH .250
7	581 32 94-01	PIN CLEVIS 5/16
8	532 42 33-03	HAIRPIN
9	585 80 83-01	PIN CLEVIS 1/4

NOTE: All component dimensions given in U.S. inches. 1 inch = 25.4 mm
IMPORTANT: Use only Original Equipment Manufacturer (O.E.M.) replacement parts. Failure to do so could be hazardous, damage your snow thrower and void your warranty.

REPAIR PARTS

CONTROL PANEL / DISCHARGE CHUTE

SNOW THROWER - MODEL NO. ST 227P (96191008800), PRODUCT NO. 961 91 00-88

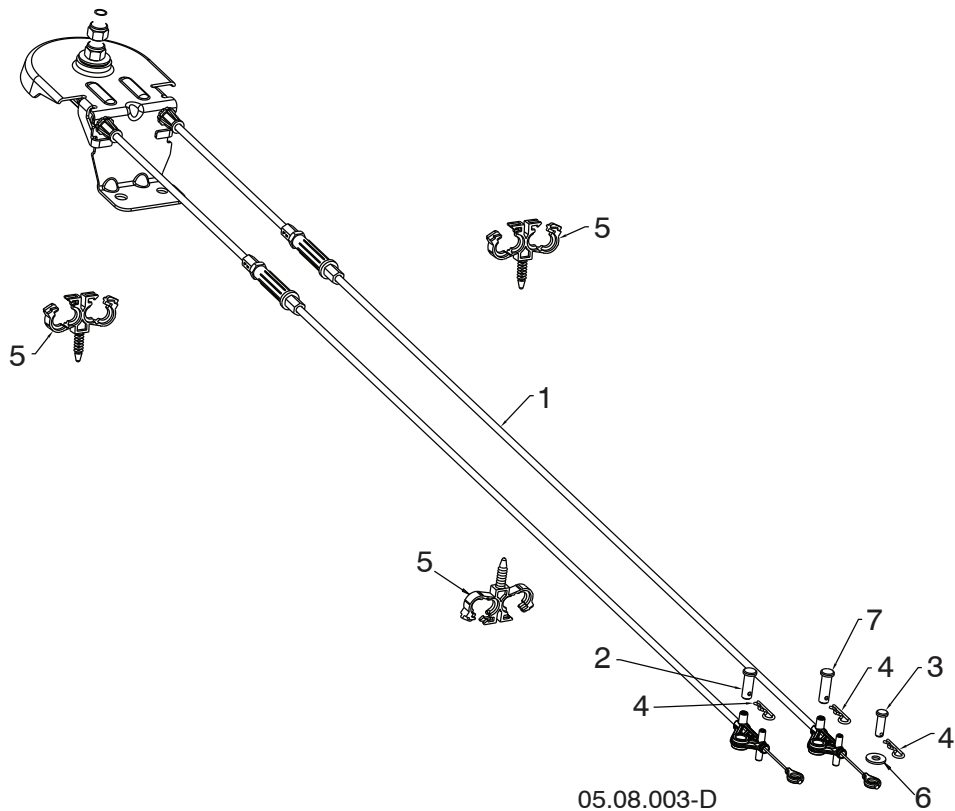

KEY NO.	PART NO.	DESCRIPTION
1	581 68 03-01	CABLE ROTATOR ASM
2	581 32 94-01	PIN CLEVIS 5/16 X 7/8
3	877 10 08-12	PIN CLEVIS 1/4 X 3/4
4	532 42 33-03	HAIRPIN SOFT ZINC
5	584 65 22-01	CLIP CONDUIT DOUBLE
6	586 68 21-01	WASHER
7	587 13 08-01	PIN CLEVIS 5/16 X 1

NOTE: All component dimensions given in U.S. inches. 1 inch = 25.4 mm
IMPORTANT: Use only Original Equipment Manufacturer (O.E.M.) replacement parts. Failure to do so could be hazardous, damage your snow thrower and void your warranty.

REPAIR PARTS

HANDLES

SNOW THROWER - MODEL NO. ST 227P (96191008800), PRODUCT NO. 961 91 00-88

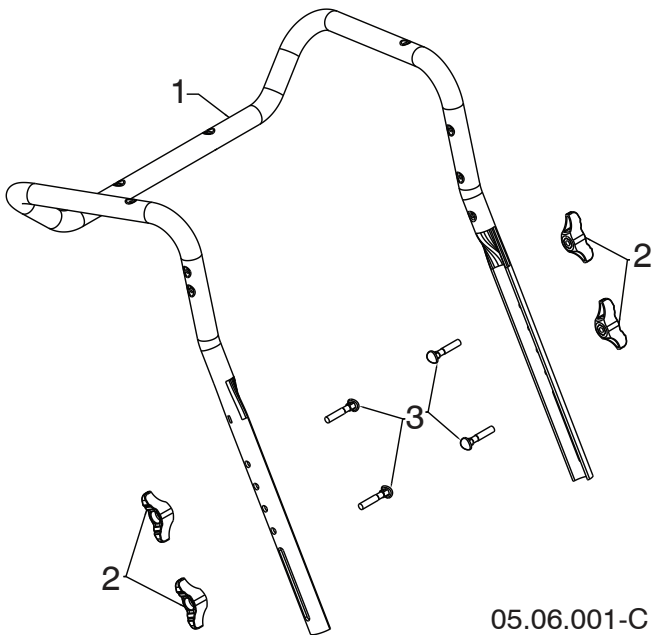

05.06.001-C

KEY NO.	PART NO.	DESCRIPTION
1	581 12 36-03	UPPER HANDLE
2	532 18 97-13	HANDLE KNOB STD BLACK
3	532 19 15-74	BOLT 5/16-18 X 1.75 CONCAVE HEAD

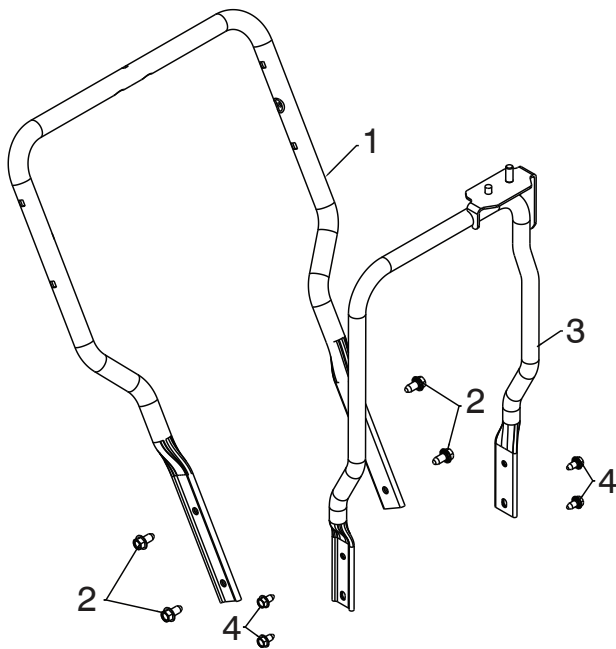

05.05.001-C

KEY NO.	PART NO.	DESCRIPTION
1	581 12 35-03	LOWER HANDLE
2	817 00 06-12	SCREW HEX WASH HD 3/8-16 X .75
3	581 62 20-02	CHUTE ROTATOR SUPPORT ASM
4	817 00 05-10	BOLT HEX 5/16-18

NOTE: All component dimensions given in U.S. inches. 1 inch = 25.4 mm
IMPORTANT: Use only Original Equipment Manufacturer (O.E.M.) replacement parts.
 Failure to do so could be hazardous, damage your snow thrower and void your warranty.

REPAIR PARTS

DRIVE

SNOW THROWER - MODEL NO. ST 227P (96191008800), PRODUCT NO. 961 91 00-88

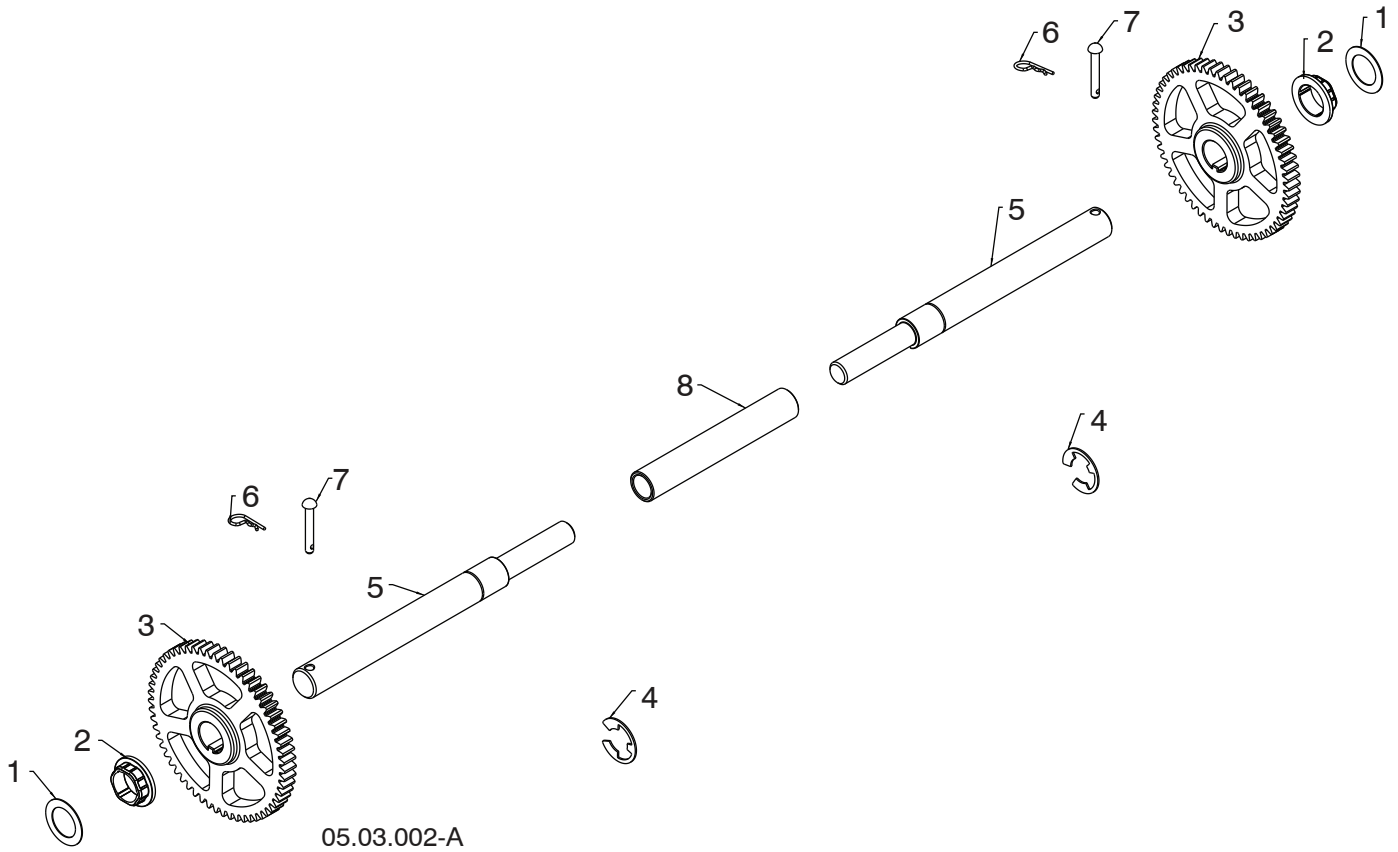

KEY NO.	PART NO.	DESCRIPTION
1	532 44 49-49	WASHER 1.00
2	581 12 23-01	BUSHING HEX 1 SHAFT
3	580 75 73-01	GEAR 59T DRIVEN
4	812 00 00-53	RETAINING RING
5	580 75 26-01	AXLE SHAFT SPLIT
6	532 12 47-88	RETAINER SPRING 1 ZINC
7	532 17 12-71	RIVET RD HD DRILLED 1/4 DIA
8	580 75 25-01	AXLE SLEEVE

NOTE: All component dimensions given in U.S. inches. 1 inch = 25.4 mm
IMPORTANT: Use only Original Equipment Manufacturer (O.E.M.) replacement parts. Failure to do so could be hazardous, damage your snow thrower and void your warranty.

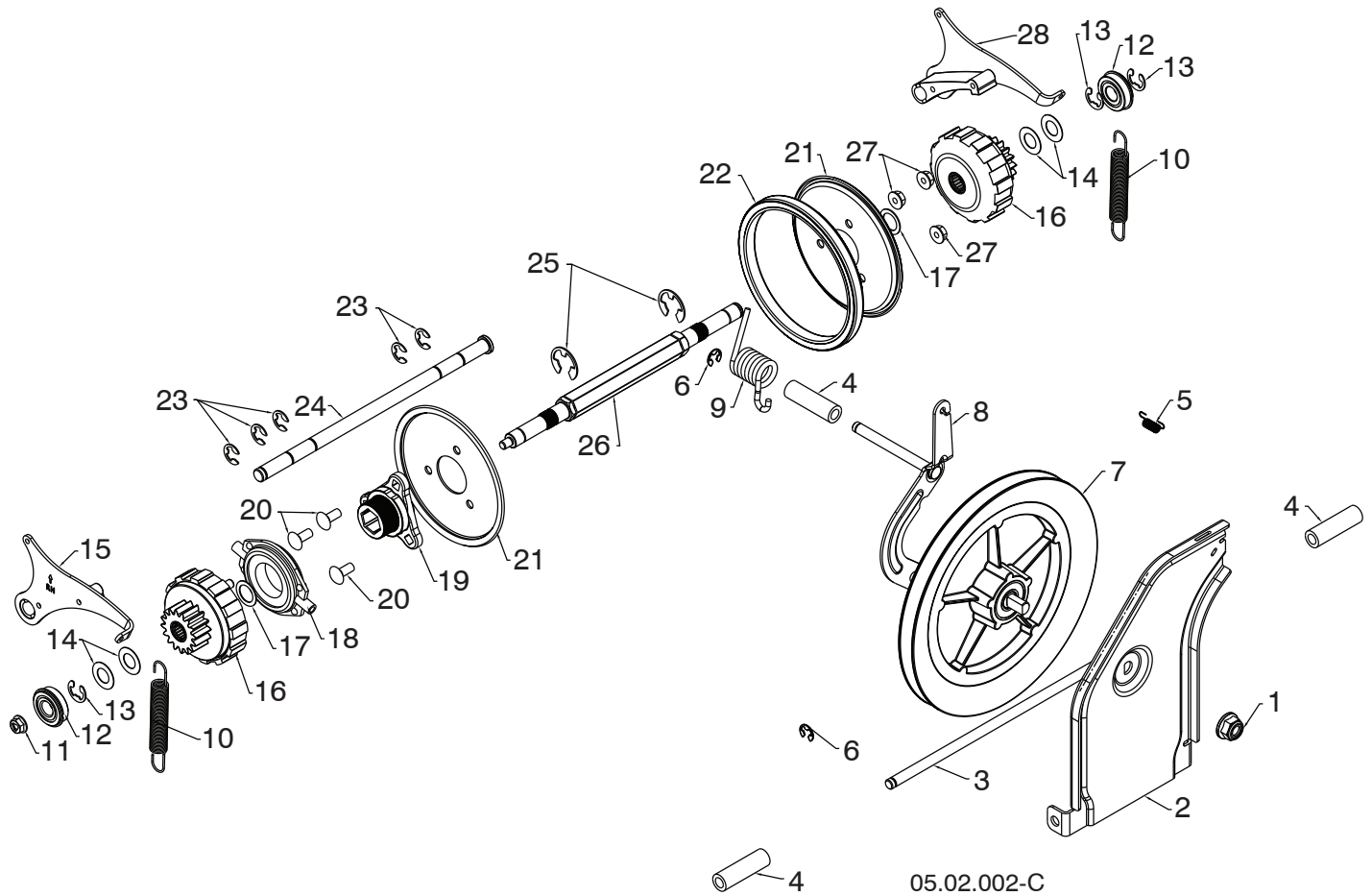

NOTE: All component dimensions given in U.S. inches. 1 inch = 25.4 mm
IMPORTANT: Use only Original Equipment Manufacturer (O.E.M.) replacement parts.
 Failure to do so could be hazardous, damage your snow thrower and void your warranty.

SNOW THROWER - MODEL NO. **ST 227P** (96191008800), PRODUCT NO. 961 91 00-88

KEY NO.	PART NO.	DESCRIPTION
1	521 99 11-01	NUT HEX FLANGE LK 1/2-13
2	581 44 69-03	SWING PLATE FRICTION PULL
3	581 12 30-01	ROD TIP PLATE
4	581 73 27-01	SPACER DRIVE
5	532 19 38-85	LATCH SPRING
6	812 00 00-07	E-RING RETAINER
7	581 32 84-01	FRICTION DISC COMBO PULLEY
8	581 45 42-03	BRACKET YOKE WELDMENT
9	581 31 53-01	SPRING TORSION DRIVE
10	585 26 38-01	EXTENSION SPRING
11	585 69 15-01	NUT HEX FLANGE LOCK 5/16-18
12	580 75 62-01	BEARING 9/16 I.D. 1622-2RSNR
13	580 75 61-01	RETAINER RING 1622-2RSNR
14	580 75 13-01	WASHER FLAT .59 I.D. X 1.065 X 25 GA
15	580 75 66-01	PAWL ASM RH
16	580 75 60-01	GEAR ASM PLANETARY
17	580 75 63--01	WASHER FLAT .6875 I.D. X 1.00 X 21 GA
18	532 17 53-44	TRUNNION BEARING ASM
19	581 09 09-01	HUB RUBBER WHEEL
20	872 11 05-06	BOLT CARRIAGE 5/16-18 X .75
21	581 09 10-02	PLATE RUBBER WHEEL
22	581 09 11-01	RING RUBBER WHEEL
23	586 64 43-01	E-RING
24	580 75 51-01	ROD PAWL
25	812 00 00-22	E-RING
26	580 75 24-01	SHAFT REDUCTION PWR STR
27	532 75 11-53	NUT HEX FLANGE LK 5/16-18
28	580 75 67-01	PAWL ASM LH

NOTE: All component dimensions given in U.S. inches. 1 inch = 25.4 mm

IMPORTANT: Use only Original Equipment Manufacturer (O.E.M.) replacement parts. Failure to do so could be hazardous, damage your snow thrower and void your warranty.

REPAIR PARTS

CHASSIS / ENGINE / PULLEYS

SNOW THROWER - MODEL NO. ST 227P (96191008800), PRODUCT NO. 961 91 00-88

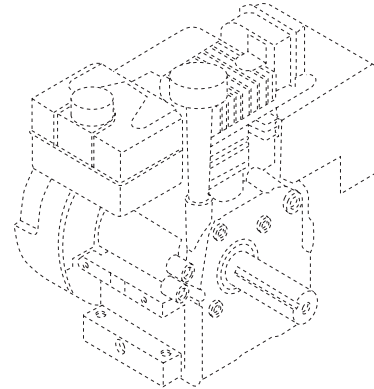
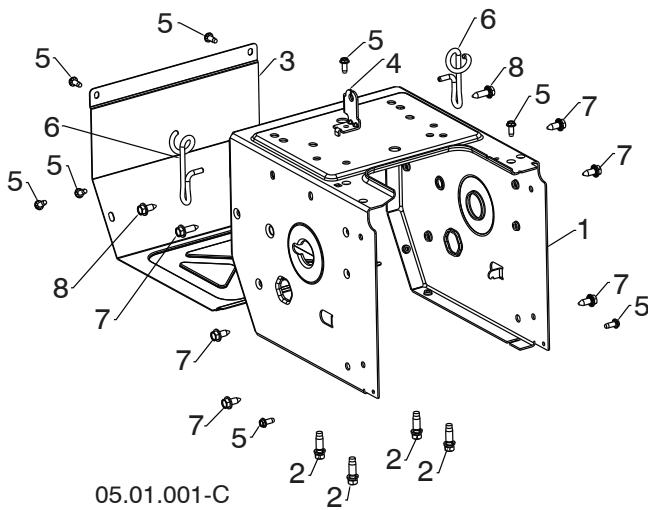

KEY NO.	PART NO.	DESCRIPTION
--	585 33 57-04	COMPLETE LCT ENGINE
1	580 83 94-05	FRAME
2	532 15 04-06	ENGINE BOLT 3/8-16 X 1.208 DOGPOINT
3	580 83 95-05	FRAME COVER
4	581 12 24-02	SHIFTER BRACKET
5	817 06 04-10	SCREW HEX WASHER 1/4-20 X 5/8
6	585 20 60-01	WIREFORM SUPPORT CABLE
7	532 42 88-67	BOLT HEXHD WASHER 5/16-18 X .75
8	585 21 75-01	BOLT HEXHD WASHER 5/16-18 X 1.00

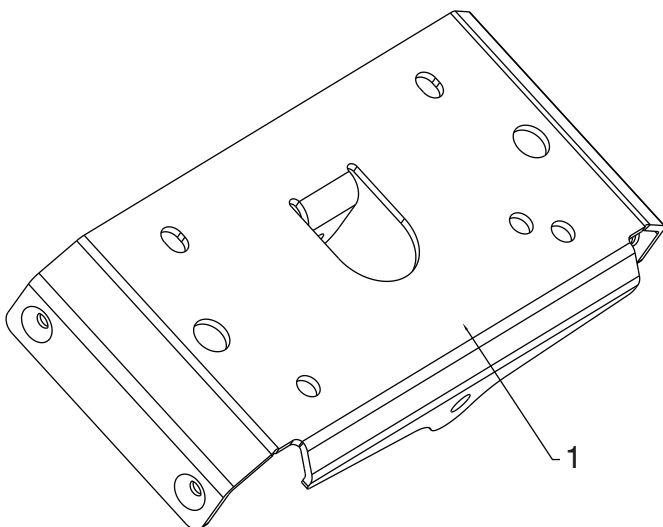

KEY NO.	PART NO.	DESCRIPTION
1	583 94 05-02	SMALL MOUNTING PLATE

NOTE: All component dimensions given in U.S. inches. 1 inch = 25.4 mm
IMPORTANT: Use only Original Equipment Manufacturer (O.E.M.) replacement parts. Failure to do so could be hazardous, damage your snow thrower and void your warranty.

REPAIR PARTS

CHASSIS / ENGINE / PULLEYS

SNOW THROWER - MODEL NO. ST 227P (96191008800), PRODUCT NO. 961 91 00-88

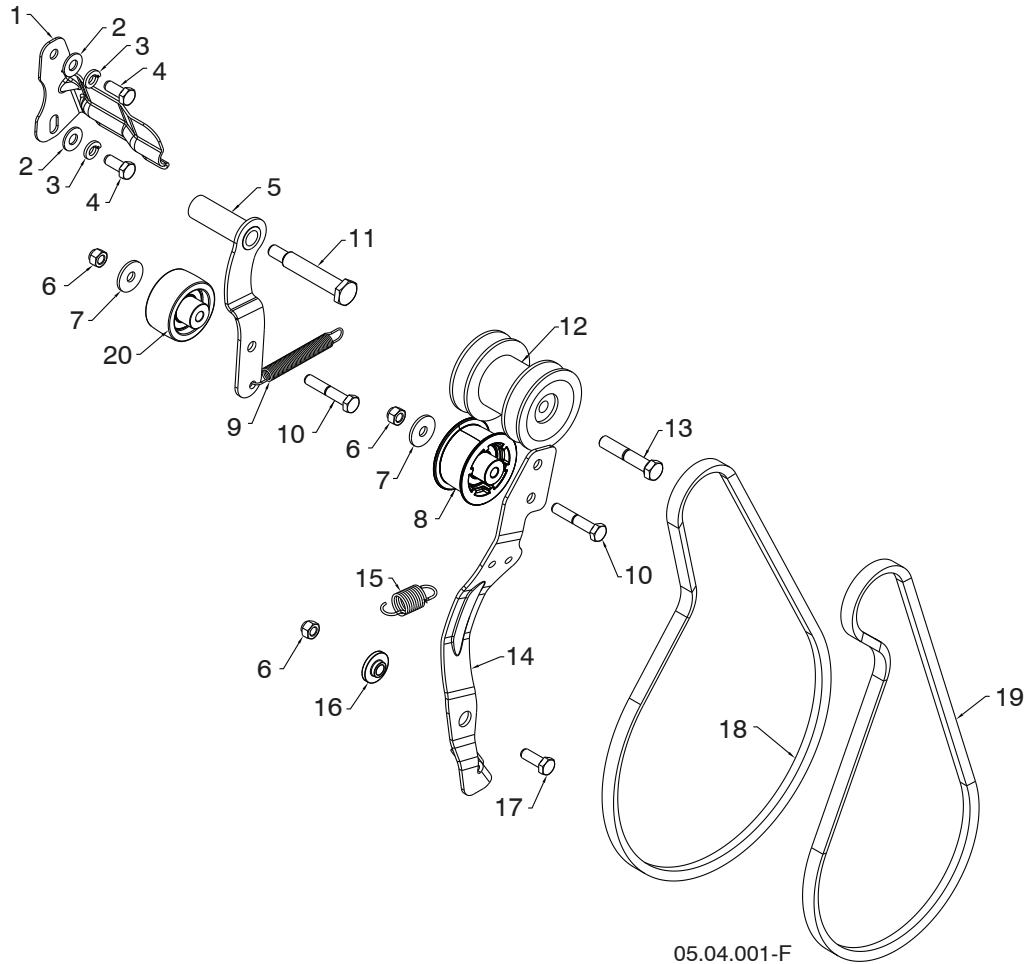

05.04.001-F

KEY NO.	PART NO.	DESCRIPTION	KEY NO.	PART NO.	DESCRIPTION
1	581 62 37-02	BELT KEEPER BRACKET	12	581 12 15-01	PULLEY ASM IMPELLER DRIVE
2	819 11 12-16	WASHER 11/32 X 3/4 X 16 GA	13	532 17 96-17	BOLT HEXHD 3/8-24 X 2.00
3	810 04 05-00	LOCKWASHER 5/16 SPLIT HVY	14	580 83 11-02	ARM IDLER
4	874 61 05-12	CAPSCREW HEXHD 5/16-24 X .75 GR5	15	587 03 12-01	RETURN SPRING IDLER ARM
5	581 33 82-02	IDLER ARM DRIVE WELDMENT	16	587 34 37-01	BUSHING IDLER PIVOT
6	873 80 05-00	NUT NYLOCK 5/16-18	17	874 76 05-14	BOLT HEXHD 5/16-18 X .875
7	532 05 92-89	WASHER FLAT .328X1.00X.097	18	584 21 61-01	DRIVE BELT 4L X 38.2
8	581 14 14-01	IDLER PULLEY 2.0 W/SPACER	19	581 83 24-01	IMPELLER BELT
9	580 75 30-01	RETURN SPRING IDLER ARM DRIVE	20	586 88 02-01	IDLER PULLEY 2.0 FLANGELSS W/SPACER
10	874 76 05-28	BOLT HEXHD 5/16-18 X 1.75			
11	581 41 38-01	SHOULDER BOLT 5/16-24 X 2.15			

NOTE: All component dimensions given in U.S. inches. 1 inch = 25.4 mm
IMPORTANT: Use only Original Equipment Manufacturer (O.E.M.) replacement parts. Failure to do so could be hazardous, damage your snow thrower and void your warranty.

REPAIR PARTS

CHASSIS / ENGINE / PULLEYS

SNOW THROWER - MODEL NO. ST 227P (96191008800), PRODUCT NO. 961 91 00-88

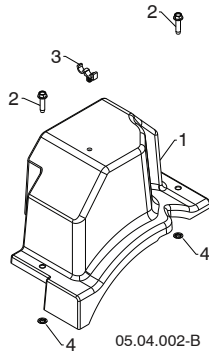

KEY NO.	PART NO.	DESCRIPTION
1	581 04 99-01	BELT COVER BLACK
2	585 69 11-01	BOLT HEX WSH THDRL 1/4-20 X 1
3	532 14 50-06	CABLE GUIDE

NOTE: All component dimensions given in U.S. inches. 1 inch = 25.4 mm
IMPORTANT: Use only Original Equipment Manufacturer (O.E.M.) replacement parts.
Failure to do so could be hazardous, damage your snow thrower and void your warranty.

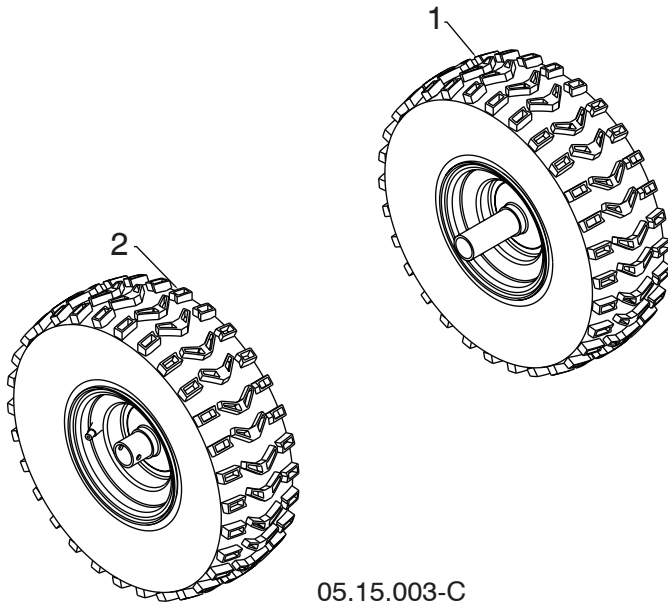

KEY NO.	PART NO.	DESCRIPTION
1	586 71 04-01	WHEEL 15X5.00 NPS LH 1.00 K478
2	586 71 03-01	WHEEL 15X5.00 NPS RH 1.00 K478

NOTE: All component dimensions given in U.S. inches. 1 inch = 25.4 mm
IMPORTANT: Use only Original Equipment Manufacturer (O.E.M.) replacement parts.
 Failure to do so could be hazardous, damage your snow thrower and void your warranty.

REPAIR PARTS

BAG OF PARTS

SNOW THROWER - MODEL NO. ST 227P (96191008800), PRODUCT NO. 961 91 00-88

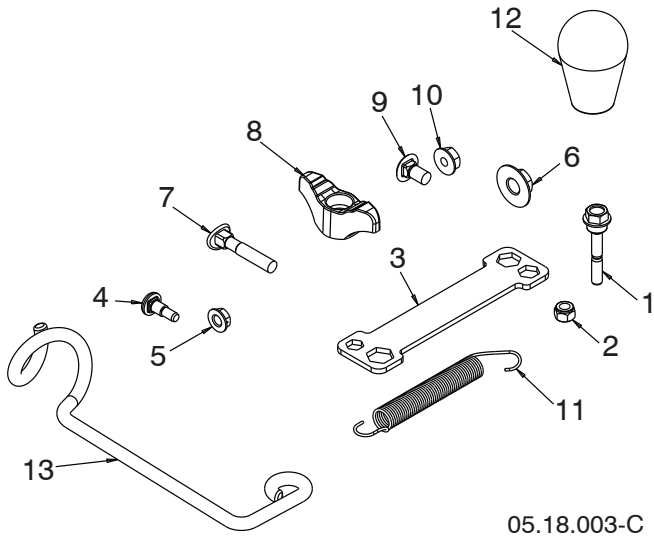

KEY NO.	PART NO.	DESCRIPTION
1	585 51 18-01	BOLT 1/4- 20 X 1.81
2	873 80 04-00	NUT NYLOCK 1/4-20
3	532 18 06-84	WRENCH
4	585 83 22-01	BOLT SHOULDER
5	585 69 14-01	NUT HEX FL 1/4-20 CTR
6	585 69 10-01	NUT NYLOCK 3/8-16
7	532 19 15-74	BOLT 5/16-18 X 1.75 CONCAVE
8	532 18 97-13	KNOB 5/16-18 TWO WING
9	585 83 20-01	BOLT 5/16-18 X .625
10	585 69 15-01	NUT FL LOCK 5/16-18
11	532 18 45-05	SPRING DEFLECT CHUTE
12	581 69 75-01	KNOB SOFT TOUCH SLOTTED
13	581 89 73-01	SUPPORT ROTATION CABLE

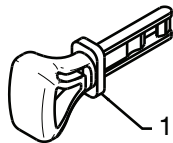

01.14.009-B

KEY NO.	PART NO.	DESCRIPTION
1	532 44 30-59	SAFETY IGNITION KEY KIT

NOTE: All component dimensions given in U.S. inches. 1 inch = 25.4 mm
IMPORTANT: Use only Original Equipment Manufacturer (O.E.M.) replacement parts.
 Failure to do so could be hazardous, damage your snow thrower and void your warranty.

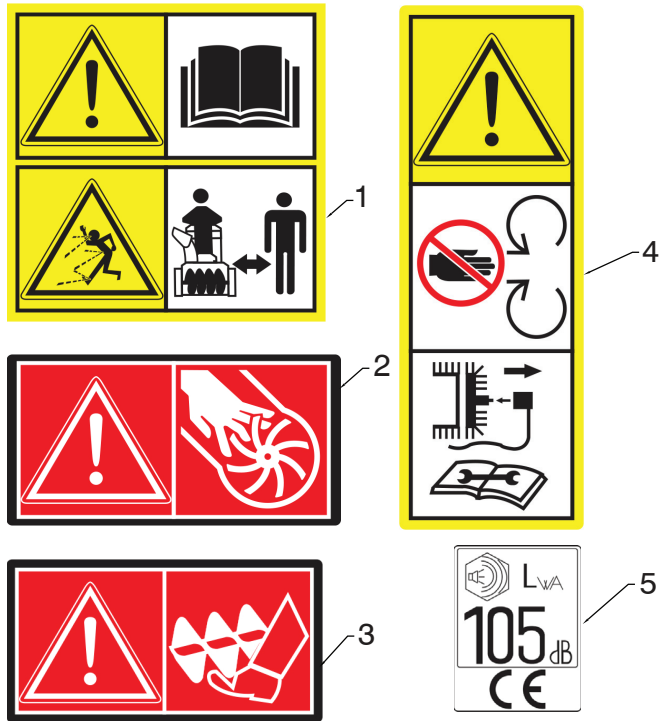

KEY NO.	PART NO.	DESCRIPTION
1	532 18 40-45	DECAL AUGER
2	532 19 96-82	DECAL CHUTE
3	532 19 96-83	DECAL AUGER SAFETY
4	532 18 40-28	DECAL BELT GUIDE
5	532 18 04-33	DECAL NOISE LEVEL

05.16.002-A

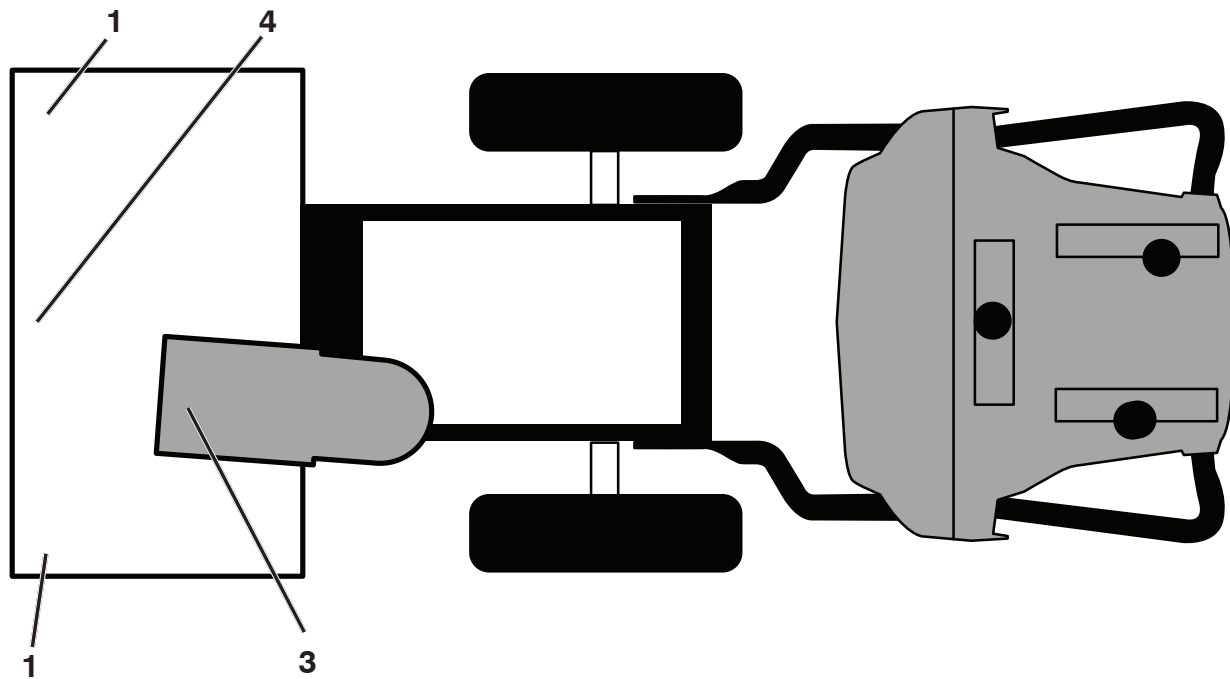

KEY NO.	PART NO.	DESCRIPTION
1	532 19 96-83	DECAL, DANGER
3	532 19 96-82	DECAL, DANGER, DEFLECTOR
4	532 18 40-45	DECAL, DANGER
--	115 68 61-20	OPERATOR'S MANUAL, EURO
--	115 68 61-10	OPERATOR'S MANUAL, SCAN
--	115 68 61-50	OPERATOR'S MANUAL, EBLOC
--	115 68 61-40	OPERATOR'S MANUAL, BALTIC

NOTE: All component dimensions given in U.S. inches. 1 inch = 25.4 mm
IMPORTANT: Use only Original Equipment Manufacturer (O.E.M.) replacement parts. Failure to do so could be hazardous, damage your snow thrower and void your warranty.

GEN II 136/179/208/254cc Snow Engines

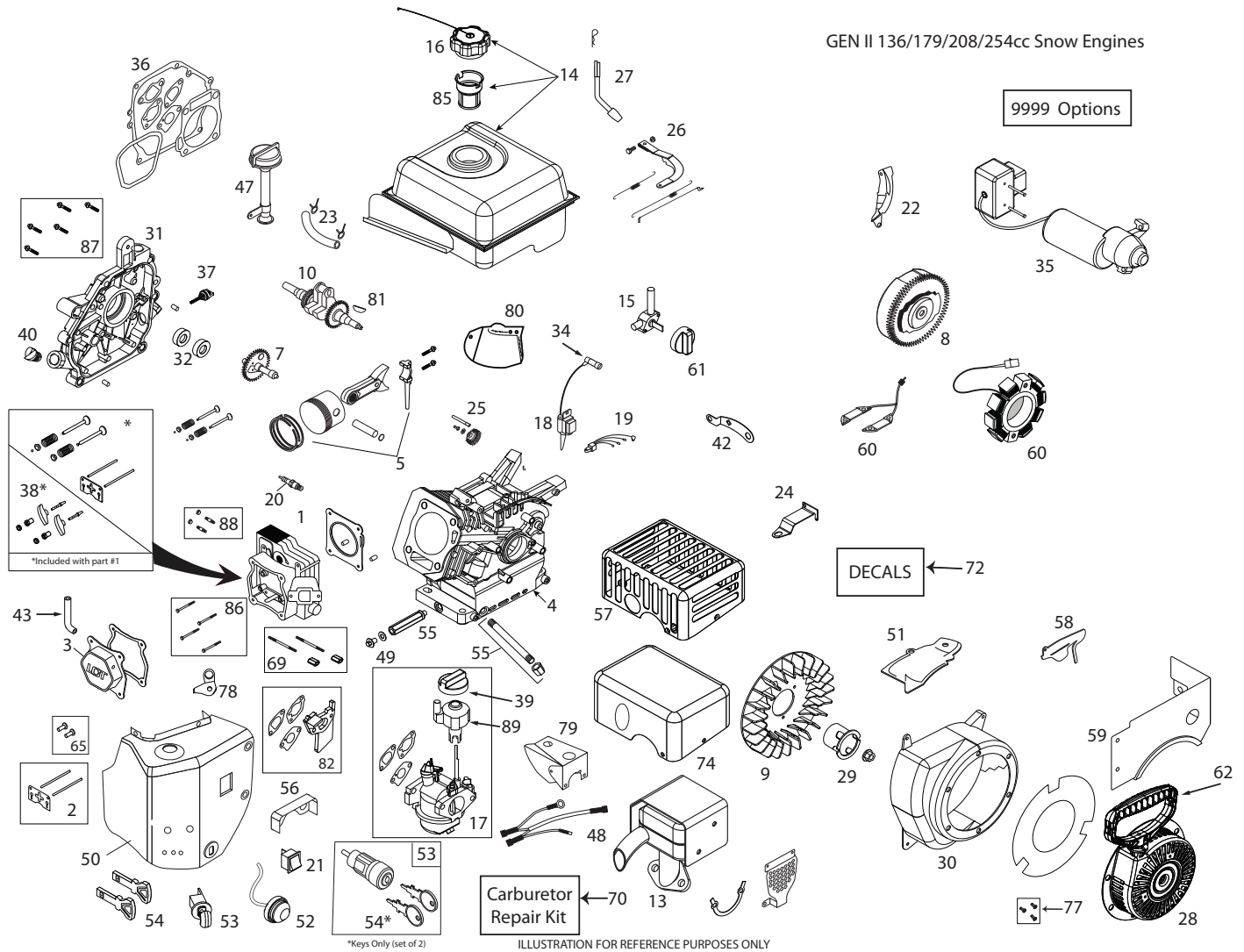

KEY PART NO.	NO.	DESCRIPTION
1	585 77 14-01	CYLINDER HEAD ASSEMBLY - 254CC (INCL. GASKET)
2	585 77 15-01	PUSH ROD & PLATE KIT (254CC) (INCL. VALVE COVER GSKT)
3	585 77 16-01	VALVE COVER (254CC) (INCL. GASKET)
4	587 15 38-01	CYLINDER - 254CC (FRONT OIL DRAIN)
5	585 77 17-01	PISTON & ROD ASSEMBLY (254CC)
7	585 77 18-01	CAMSHAFT - MCR (254CC)
8	585 77 19-01	FLYWHEEL - ELECTRIC START (8-CHARGING MAGNETS) (254CC)
9	532 42 05-86	COOLLNG FAN - FLYWHEEL (PLASTIC - 208CC)
10	587 15 39-01	CRANKSHAFT (#18 KEYED 254CC SNOW)

KEY PART NO.	NO.	DESCRIPTION
13	585 77 21-01	MUFFLER ASSEMBLY-GEN LL SNOW (254CC)
14	587 15 40-01	FUEL TANK (2.7L GLOSS BLACK) (254CC SNOW)(ORDER DECAL KIT SEPARATE)
15	532 42 92-34	FUEL TANK ON/OFF VALVE - GEN II SNOW
16	532 42 49-42	FUEL TANK CAP - BLACK CLLCK STYLE (VENTED)
17	587 15 41-01	CARBURETOR (L15D) (254CC SNOW W/IDLE-DOWN CONTROL) (W/GSKTS)
18	532 44 38-94	IGNITION COIL (CDI) (208/254CC) (HI-TEMP)
20	532 44 38-98	SPARK PLUG - PLATINUM
21	532 42 49-57	ON/OFF SWITCH - ROCKER
22	585 77 24-01	SHIELD - FLYWHEEL (ELECTRIC 208CC)

ENGINE, LCT**COMPLETE ENGINE-585335704**

KEY NO.	PART NO.	DESCRIPTION	KEY NO.	PART NO.	DESCRIPTION
23	532 43 21-44	FUEL HOSE -1/4 (318MM)(CUT TO 240MM)	53	532 42 49-54	KEY SWITCH - SAFETY (PUSH/PULL) SNOW (INCL. KEYS)
24	585 77 25-01	SPEED CONTROL BRACKET (FIXED)(254CC SNOW)	54	532 44 30-59	KEY SET - RED (2) (SNOW)
25	532 42 96-46	GOVERNOR GEAR ASSEMBLY (136/208CC)	55	587 15 44-01	FRONT OIL DRAIN PIPE & NUT ASSY
26	585 77 26-01	GOVERNOR ARM & LINK KIT (254CC SNOW)	56	585 77 33-01	CARBURETOR VAPOR SHIELD (254CCSNOW)
27	532 42 06-02	GOVERNOR ARM PADDLE	57	532 43 66-72	CE COMPLIANT MUFFLER SHIELD
28	532 43 69-67	RECOIL STARTER (ROUND STYLE-BLACK) 136/208CC GEN II SNOW	58	585 77 34-01	SHIELD - GOVERNOR LINKAGE (254CC-SNOW)
29	532 43 69-68	STARTER CUP (USE WITH ROUND STYLE STARTER) (208CC SNOW)	59	587 15 45-01	FUEL TANK SKIRT SHIELD (GLOSS BLACK-254CC)(ORDER DECAL KIT SEPARATE)
30	587 15 42-01	BLOWER HOUSING (GLOSS BLACK)(254CC SNOW W/FRONT DRAIN)(ORDER DECAL KIT SEPARATE)	60	532 44 38-93	CHARGING COIL (60-WATT AC) (208/254CC)
31	585 77 27-01	CRANKCASE COVER (PRESS-IN TYPE HIGH OIL-FILL TUBE)	61	532 43 27-52	FUEL CONTROL KNOB (GEN II SNOW - RED)
32	585 77 28-01	OIL SEAL KIT (2 PCS)	62	532 44 38-99	STARTER GRIP-SNOW (DELUXE)
34	532 43 69-66	SPARK PLUG BOOT - WITH METAL SHIELD (SNOW)	65	581 37 28-01	TAPPET KIT (208/254CC)(SET OF 2)
35	532 43 66-71	230V EU ELECTRIC STARTER (208/254CC GEN LL) (MOUNTING BOLTS ON SIDE OF BLOCK)	69	532 42 49-51	CARBURETOR STUDS & COU-PLING KIT-SNOW
36	585 77 29-01	ENGINE GASKET KIT (254CC)	70	580 35 36-01	CARBURETOR REPAIR KIT (136/208/254CC)
38	585 77 30-01	ROCKER ARM KIT (254CC)(INCL. GASKET)	74	581 76 88-01	MUFFLER HEAT SHIELD COVER (136/208/254)
39	532 42 92-24	CHOKE CONTROL KNOB (GEN II RED)	77	532 43 26-88	RECOIL BOLT KIT (INCL. (3) MTG BOLTS)
40	532 42 95-98	NON-REMOVABLE PLASTIC PLUG (136/208/254CC)	79	585 77 37-01	CARBURETOR COVER (136/208/254CC SNOW)
43	580 35 34-01	BREATHER TUBE (136/208/254CC)	80	585 77 38-01	SHIELD GOVERNOR LINK - 254CC SNOW
47	581 00 72-01	HIGH OIL-FILL TUBE/DIPS-TICK (PRESS-IN TYPE) (SN >1265H0519257)	81	582 09 72-02	WOODRUFF FLYWHEEL KEYS (5-PACK) (5X6X18MM)
48	532 42 92-62	WIRE HARNESS (208CC SNOW)	82	585 02 05-03	CARBURETOR SPACER (208/254CC)
49	532 43 54-95	OIL DRAIN PLUG W/WASHER (136/208/254CC)	85	583 02 56-01	FUEL TANK STRAINER
50	587 15 43-01	HEATER BOX ASSEMBLY (GLOSS BLACK-254CC)(ORDER DECAL KIT SEPARATE)	86	586 32 73-01	CYLINDER HEAD BOLT KIT (4) (136-179-208-254CC)
52	532 42 49-49	PRIMER BULB WITH HOSE-SNOW	87	586 32 69-01	CC COVER BOLT KIT (6) (179-208-254CC)
			88	586 32 68-01	MUFFLER MTG STUD KIT (2)
			89	587 12 48-01	SPEED CONTROL KNOB, GEN II, SNOW
			9999	587 15 48-01	HIGH ALTITUDE JET (>5,000 FEET)(254CC L15 CARBURETOR)

