

# ILLUSTRATED PARTS LIST

**MODEL NO. 96041028302**

**CUSTOMER CATALOG NO. LTH2038R**

**PRODUCT NO. 960 41 02-83**

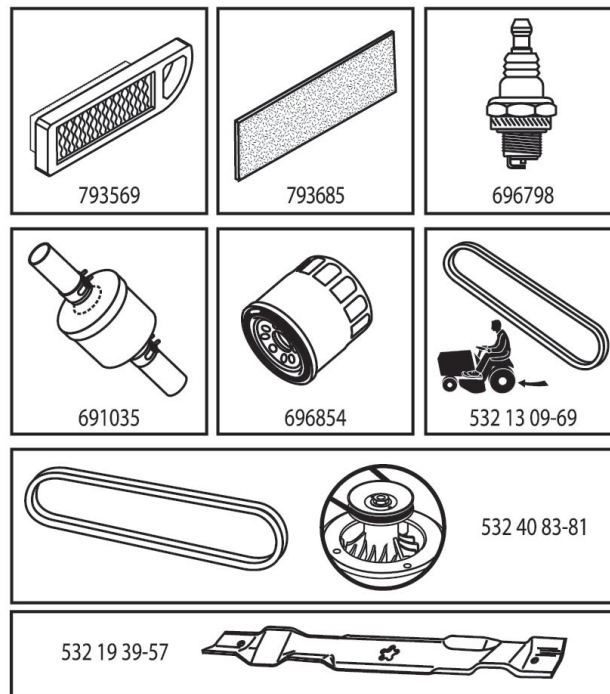

**47**

443835

TRACTOR - - MODEL NO. LTH2038R (96041028302), PRODUCT NO. 960 41 02-83  
 DECALS **27**

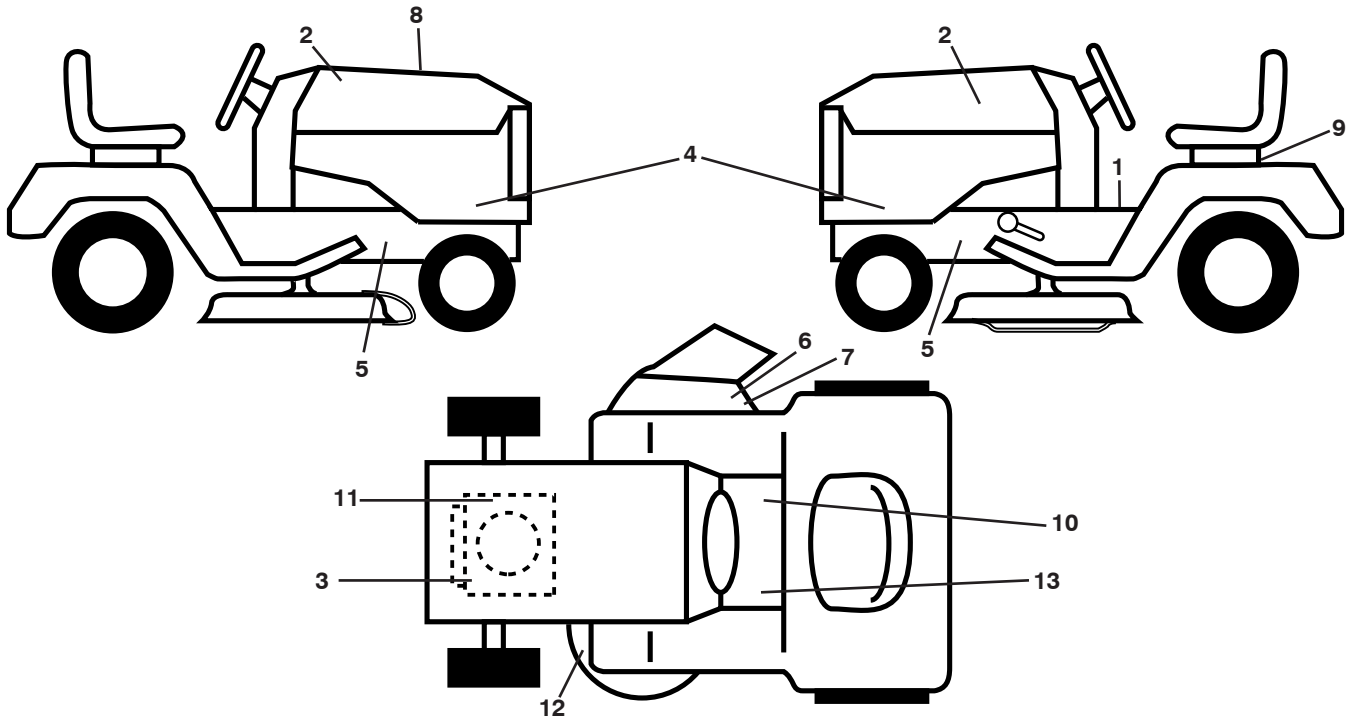

KEY NO.	PART NO.	DESCRIPTION
1	581 57 81-01	Decal, Operators
2	581 62 73-01	Decal, Hood RH/LH
3	581 57 97-01	Decal, Warning Eng. Symbols
4	532 44 85-50	Decal, SDPNL
5	581 57 96-01	Decal, Chassis Hot Muffler
6	584 90 46-01	Decal, Deck/Deflect. Warning
7	581 57 92-01	Decal, Warning
8	532 44 38-35	Decal, RPL
9	532 14 50-05	Decal, Battery Dnge/Poi

KEY NO.	PART NO.	DESCRIPTION
10	581 57 80-01	Decal, Saddle Brake Parking
11	587 21 59-01	Decal, Engine HP
12	581 58 00-03	Decal, Mower V-Belt Schematic
13	581 72 40-01	Decal, Brake/Clutch Symbol
--	581 72 46-01	Decal, Drawbar Load Limit
--	581 72 48-01	Decal Bypass
--	532 43 96-81	Pad, Footrest, LH
--	532 43 96-82	Pad, Footrest, RH
--	587 23 11-28	Manual Oper. English

**WHEELS AND TIRES**

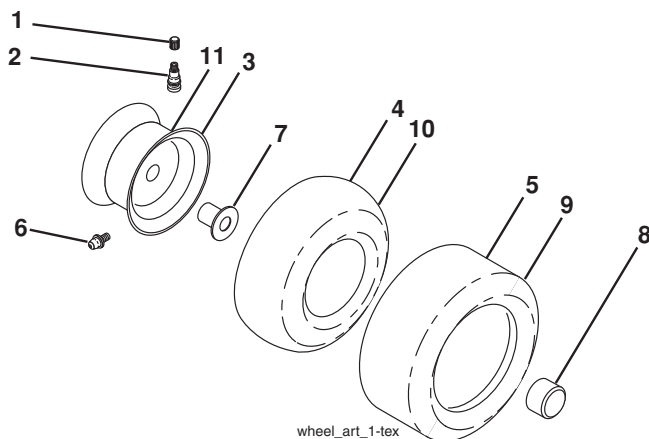

KEY NO.	PART NO.	DESCRIPTION
1	532 05 91-92	Cap Valve Tire
2	532 06 51-39	Stem Valve
3	532 13 83-36	Rim Asm 6" Front Service
4	532 05 99-04	Tube Front (Service Item Only)
5	532 10 62-22	Tire Front 15 x 6-6
6	532 12 49-57	Fitting Grease (Front Wheel Only)
7	532 12 49-59	Bearing Flange (Front Wheel Only)
8	532 17 50-39	Cap Axle Blk 1 50 x 1 00
9	532 12 20-82	Tire Rear 20 x 10-8
10	532 12 49-26	Tube Rear (Service Item Only)
11	532 13 83-37	Rim Asm 8" Rear Service
--	532 14 43-34	Sealant, Tire (10 oz. Tube)

**NOTE:** All component dimensions given in U.S. inches  
 1 inch = 25.4 mm

# TRACTOR - - MODEL NO. LTH2038R (96041028302), PRODUCT NO. 960 41 02-83

## SCHEMATIC **38**

SCH11

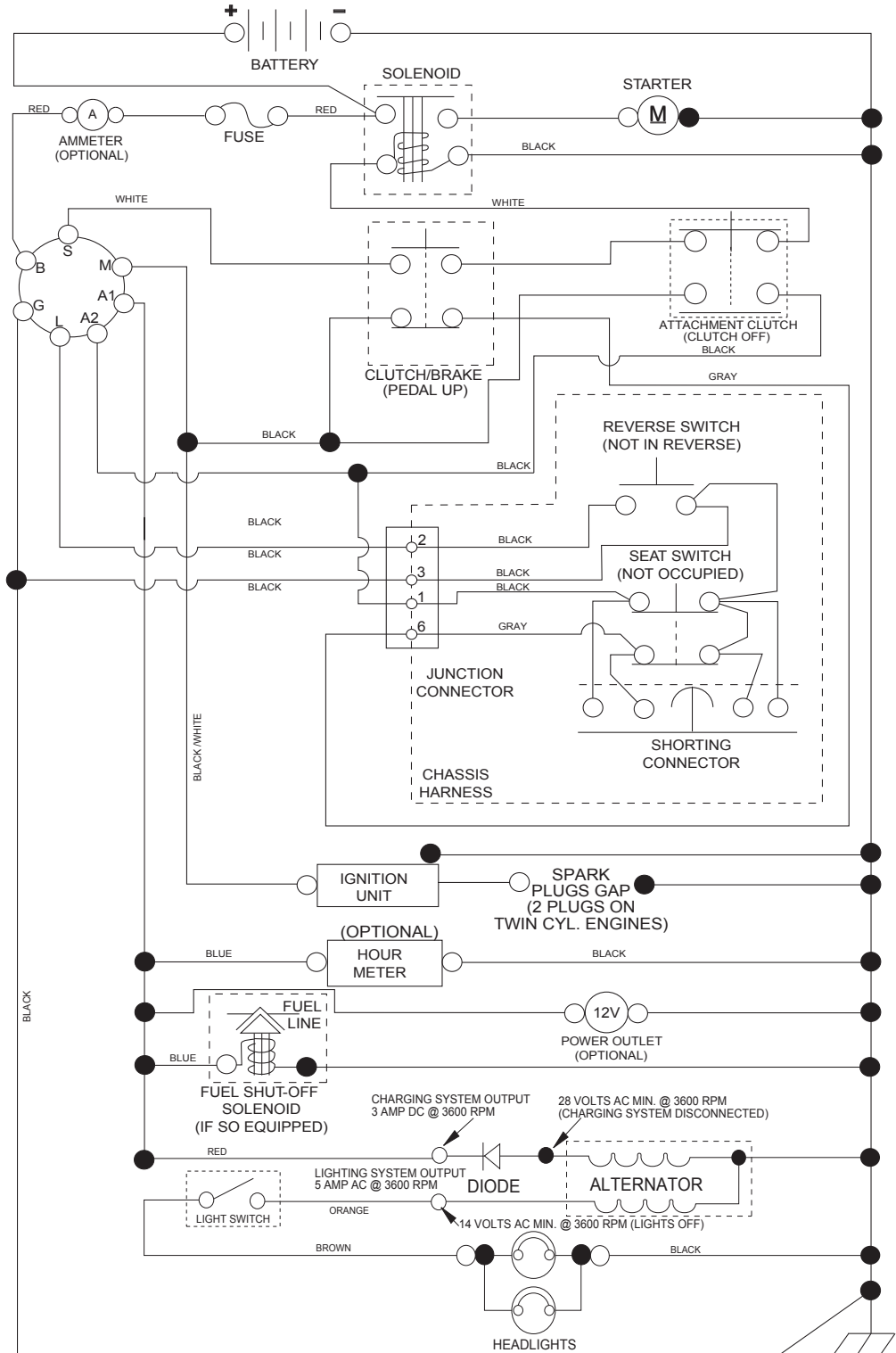

**NOTE**  
YOUR TRACTOR IS EQUIPPED WITH A SPECIAL ALTERNATOR SYSTEM. THE LIGHTS ARE NOT CONNECTED TO THE BATTERY, BUT HAVE THEIR OWN ELECTRICAL SOURCE. BECAUSE OF THIS, THE BRIGHTNESS OF THE LIGHTS WILL CHANGE WITH ENGINE SPEED. AT IDLE THE LIGHTS WILL DIM. AS THE ENGINE IS SPEEDED UP, THE LIGHTS WILL BECOME THEIR BRIGHTEST.

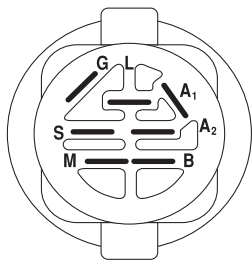

IGNITION SWITCH

POSITION	CIRCUIT	"MAKE"
OFF	M+G+A1	
RUN/OVERRIDE	B+A1	
RUN	B+A1	L+A2
START	B + S + A1	

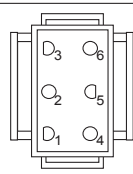

CHASSIS HARNESS CONNECTOR (MATING SIDE)

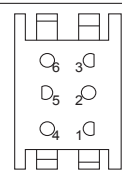

DASH HARNESS CONNECTOR (MATING SIDE)

WIRING INSULATED CLIPS  
NOTE: IF WIRING INSULATED CLIPS WERE REMOVED FOR SERVICING OF UNIT, THEY SHOULD BE RE-INSTALLED TO PROPERLY SECURE YOUR WIRING.

NON-REMOVABLE CONNECTIONS

REMOVABLE CONNECTIONS

TRACTOR - - MODEL NO. LTH2038R (96041028302), PRODUCT NO. 960 41 02-83  
 ELECTRICAL **32**

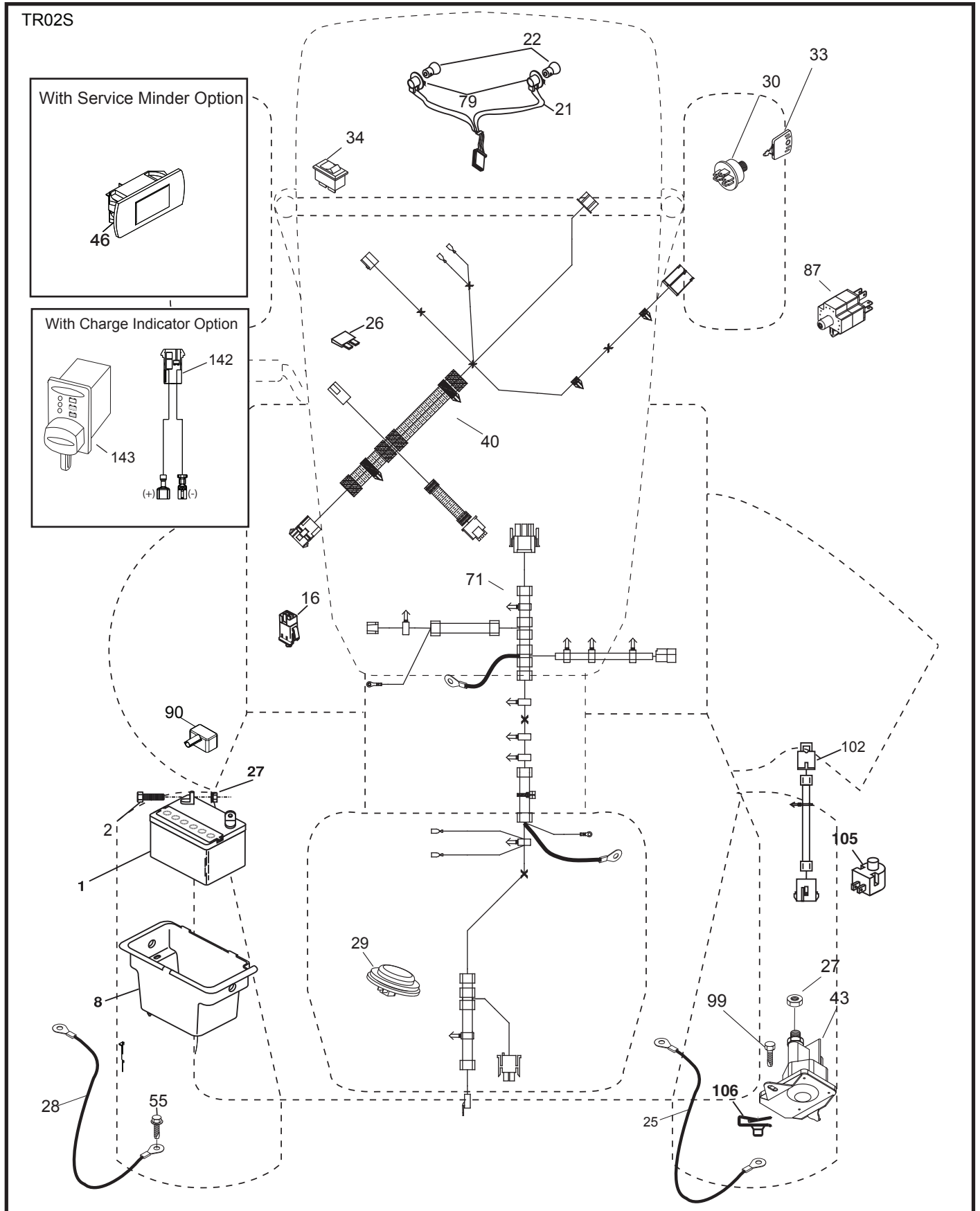

**TRACTOR - - MODEL NO. LTH2038R (96041028302), PRODUCT NO. 960 41 02-83  
ELECTRICAL 32**

<b>KEY NO.</b>	<b>PART NO.</b>	<b>DESCRIPTION</b>
1	532 16 34-65	Battery
2	874 76 04-12	Bolt Hex Head 1/4-20 x 3/4
8	532 19 32-28	Box Battery
16	532 17 61-38	Switch Interlock Push-In
21	532 40 02-52	Harness Socket Light w/4152J
22	532 00 41-52	Bulb Light
25	581 49 80-01	Cable Starter
26	532 17 51-58	Fuse
27	873 51 04-00	Nut Keps Hex 1/4-20 unc
28	532 42 16-86	Cable, Ground
29	532 40 15-45	Switch, Seat
30	532 19 33-50	Switch, Ign
33	532 41 19-33	Key/Chain
34	532 11 07-12	Switch Light/Reset
40	581 02 31-01	Harness Ign. Dash
43	532 19 25-07	Solenoid
46	586 16 18-01	Gauge, Hourmeter
55	817 06 05-12	Screw Thdrol 5/16-18 x 3/4 TYTT
71	581 02 30-01	Harness Ign.
79	532 17 52-42	Socket Asm Bulb Twistlock
87	532 19 78-02	Switch Interlock Clutch Cable
90	532 43 53-95	Cover Terminal
99	817 67 04-12	Screw Hexwsh Thdrol 1/4-20 x 3/4
102	532 40 44-54	Harness Pigtail
105	532 40 75-68	Switch Reverse TT Pedal Control
106	532 17 48-14	Palnut 1/4 Lugs

**NOTE:** All component dimensions given in U.S. inches  
1 inch = 25.4 mm

TRACTOR - - MODEL NO. LTH2038R (96041028302), PRODUCT NO. 960 41 02-83  
CHASSIS AND ENCLOSURES **39**

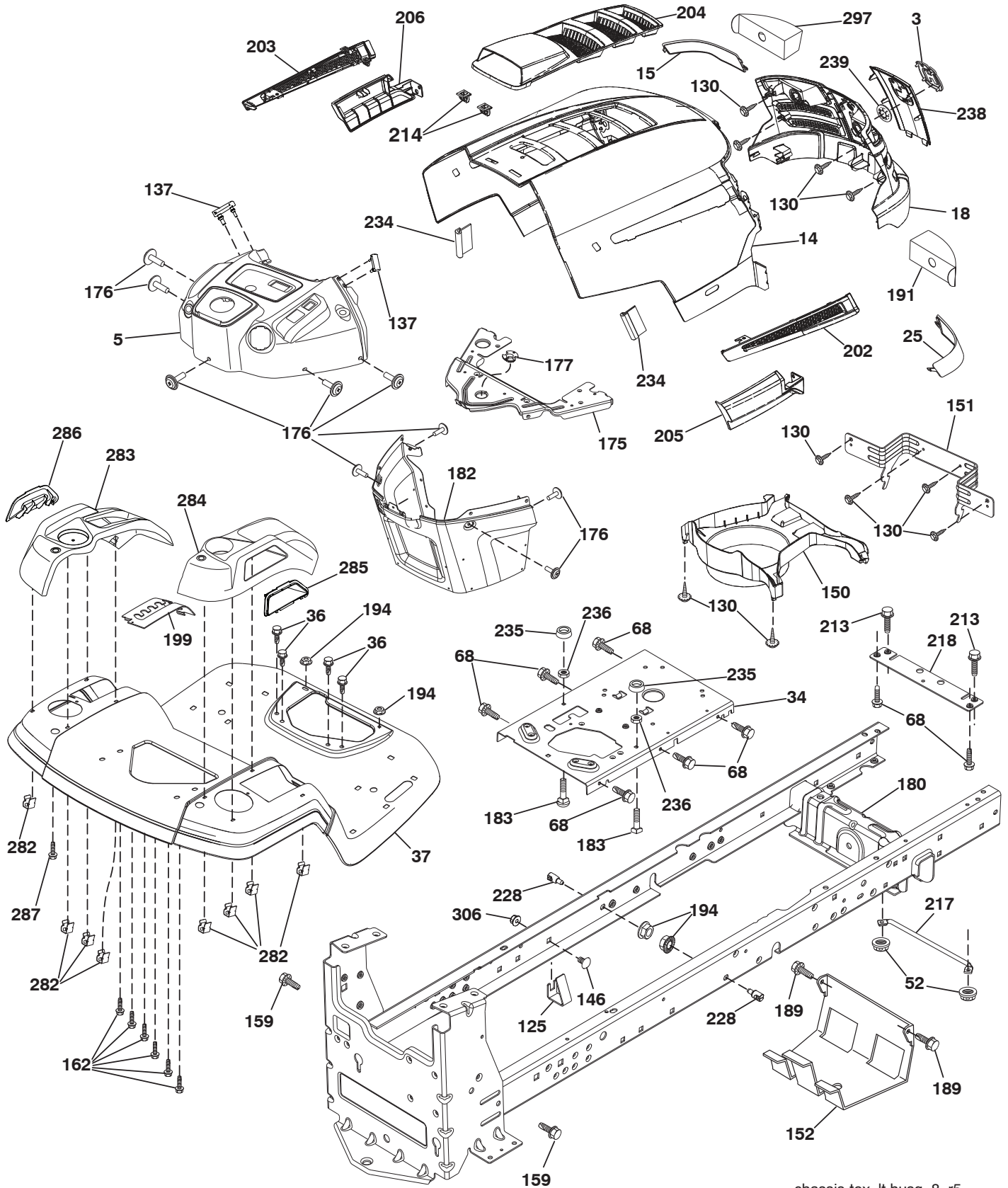

chassis-tex\_lt husq\_8\_r5

**TRACTOR - - MODEL NO. LTH2038R (96041028302), PRODUCT NO. 960 41 02-83  
CHASSIS AND ENCLOSURES **39****

KEY NO.	PART NO.	DESCRIPTION	KEY NO.	PART NO.	DESCRIPTION
3	581 05 63-01	Logo	202	532 44 13-42	Vent Side Hood RH
5	532 43 89-64	Dash	203	532 44 13-43	Vent Side Hood LH
14	532 44 12-67	Hood	204	532 44 13-75	Vent Top Hood
15	532 44 14-28	Lens LH	205	532 44 13-44	Skirt Side RH
18	532 44 13-68	Grille	206	532 44 13-45	Skirt Side LH
25	532 44 14-27	Lens RH	213	874 76 05-12	Bolt 5/16-18 x 3/4
34	580 91 08-01	Plate Engine	214	532 19 91-45	Clip Retainer
36	817 06 05-12	Screw 5/16-18 x 3/4	217	532 40 91-67	Rod Pivot Hood
37	532 44 12-66	Fender	218	532 19 63-95	X-Piece Hood Stop
52	873 68 05-00	Nut Crown Lock 5/16	228	532 19 51-61	Stud Fastener
68	817 49 05-08	Screw THDROL 5/16-18 x 1/2	234	532 40 47-42	Bumper Hood
125	581 68 48-01	Clip Fuel Line	235	532 40 61-29	Spacer Fender
130	532 41 63-58	Screw 10 x 0.750	236	873 93 05-00	Nut Lock 5/16-18 unc
137	532 40 75-90	Bumper, Dash	238	532 44 13-74	Trim
146	581 85 79-01	Bolt	239	532 40 48-83	Clip Tinnerman
150	532 40 66-62	Air Duct	282	532 41 41-10	Clip Retainer Console
151	532 40 78-07	Bracket Pivot	283	532 44 20-39	Console Deck Lift
152	532 19 95-35	Shield Browning	284	532 43 98-23	Console Control Pedal
159	817 00 06-12	Screw 3/8-16 x 3/4	285	532 41 63-15	Console Insert RH
162	532 14 24-32	Screw	286	532 41 63-17	Console Insert LH
175	532 19 94-72	Crossmember	287	817 60 04-06	Screw 1/4-20 x 3/8
176	532 40 07-76	Screw 10-24 x 5/8	297	532 40 66-65	Insert Reflective LH
177	532 19 52-28	Bushing Steering	306	873 90 06-00	Nut Lock
180	532 19 54-57	Chassis	--	532 40 09-44	Kit Bumper
182	532 40 71-76	Dash Lower			
183	874 52 05-20	Bolt 5/16-18 x 1-1/4			
189	817 00 05-12	Screw 5/16-18 x 3/4			
191	532 41 65-01	Insert Reflective RH			
194	873 90 05-00	Nut Lock Hex Flange 5/16-18			
199	532 41 34-85	Plate Deck Lift			

**NOTE:** All component dimensions given in U.S. inches  
1 inch = 25.4 mm

TRACTOR - - MODEL NO. LTH2038R (96041028302), PRODUCT NO. 960 41 02-83  
DRIVE **40**

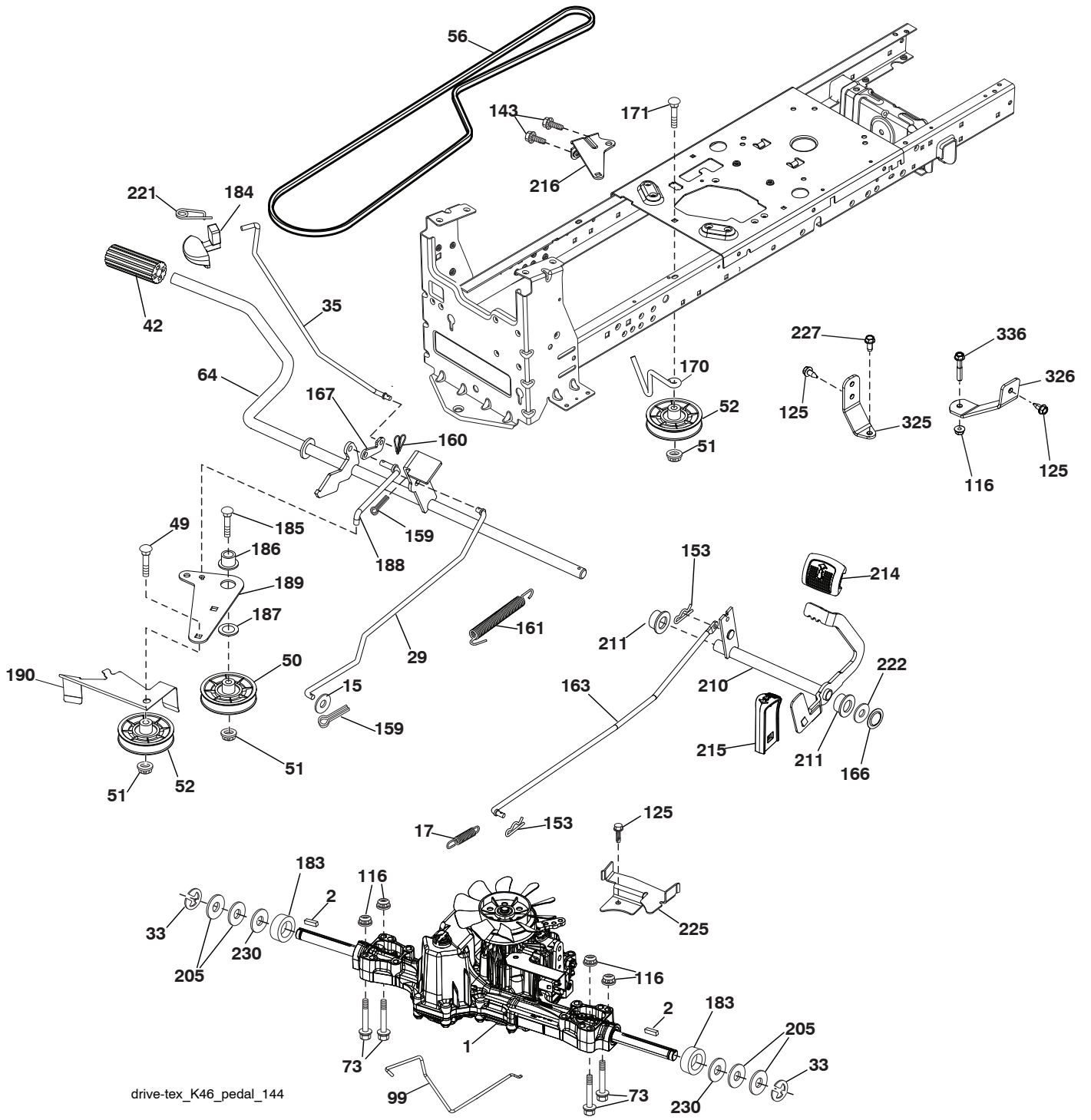

drive-tex\_K46\_pedal\_144



**TRACTOR - - MODEL NO. LTH2038R (96041028302), PRODUCT NO. 960 41 02-83  
DRIVE 40**

KEY NO.	PART NO.	DESCRIPTION
1	-----	Transaxle, TUFFTORQ K46BT (426120) (Order parts from transaxle manufacturer.)
2	532 12 35-83	Key Square
15	819 13 13-16	Washer 13/32 x 13/16 x 16 Ga.
17	532 41 36-78	Spring, Brake
29	532 40 38-06	Rod, Brake
33	812 00 00-01	Ring E
35	532 40 10-31	Rod, Brake, Park
42	532 12 48-72	Cover, Foot Pedal
49	872 11 06-14	Bolt
50	532 19 43-27	Pulley Idler Flat
51	873 90 06-00	Lock Nut 3/8-16
52	532 19 43-26	Idler V-Groove Offset
56	532 13 09-69	V-Belt, Drive
64	532 19 78-65	Shaft Asm. Pedal Brake Control
73	874 49 05-40	Bolt 5/16-18 Gr. 5
99	532 41 57-42	Rod Bypass
116	873 90 05-00	Nut Lock Hex Flange 5/16-18
125	817 00 05-12	Screw 5/16-18 x 3/4
143	817 49 05-08	Screw 5/16-18 x 1/2
153	532 12 47-88	Retainer Spring
159	876 02 04-12	Pin Cotter 1/8 x 3/4
160	532 16 94-84	Retainer Clip
161	532 10 57-09	Spring Return Clutch
163	532 44 82-75	Rod Pedal Control
166	532 42 91-64	Nut Push
167	532 40 52-57	Latch Brake Parking
170	532 19 43-22	Keeper Belt Centerspan
171	872 11 06-16	Bolt
183	532 13 70-57	Spacer Axle
184	532 41 14-84	Handle Parking Brake
185	872 11 06-22	Bolt
186	532 19 43-21	Spacer Retainer
187	819 13 32-10	Washer
188	532 19 43-23	Link Clutch Ground Drive
189	532 19 43-17	Bellcrank Ground Drive
190	532 19 43-18	Keeper Bellcrank Ground Drive
205	532 12 17-48	Washer 25/32 x 1-5/8 16 Ga.
210	532 40 09-80	Rockr Asm. Pedal Control
211	532 12 01-83	Bearing Nylon
214	532 42 12-63	Pedal Forward
215	532 40 17-23	Pedal Reverse
216	532 19 61-31	Bracket Pulley Idler
221	532 40 31-87	Retainer Spring Clip
222	879 21 20-10	Washer 21/32 x 1-1/4 10 Ga.
225	532 40 33-19	Keeper Bolt Transaxle
227	817 49 05-12	Screw 5/16-18 x 3/4
230	532 18 89-67	Washer Hardened
325	585 66 85-02	Torque Strap K46 LT RH
326	585 67 08-02	Bracket Trq Stp 46 20" Tire RH
336	587 25 96-01	Bolt 5/16-18 x 1-3/4 Flanged

**NOTE:** All component dimensions given in U.S. inches  
1 inch = 25.4 mm

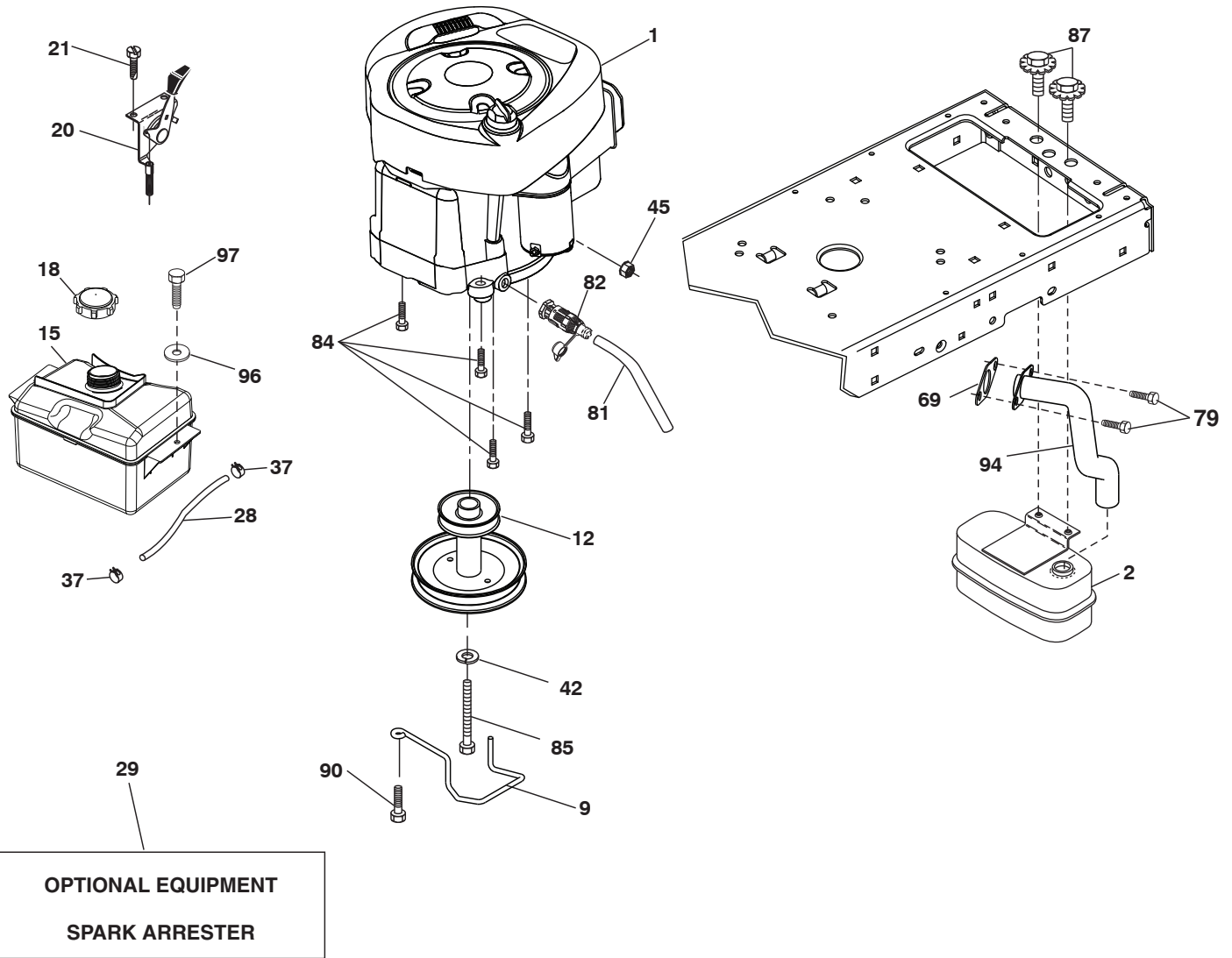

engine-tex\_BS\_77

**TRACTOR - - MODEL NO. LTH2038R (96041028302), PRODUCT NO. 960 41 02-83  
ENGINE 24**

<b>KEY NO.</b>	<b>PART NO.</b>	<b>DESCRIPTION</b>
1	-----	Engine B&S Model No. 33S777-0002-G1 (587195701)(Order parts from engine manufacturer.)
2	580 53 23-01	Muffler
9	584 90 80-01	Keeper Belt Engine
12	532 40 54-71	Pulley Engine
15	581 28 99-01	Tank Fuel 1.5
18	532 43 02-20	Cap Asm Fuel
20	532 18 38-97	Control Throttle
21	532 41 63-58	Screw #10 x .750 BOS Thread
28	532 13 70-40	Fuel Line
29	532 13 71-80	Spark Arrester Kit
37	532 12 34-87	Clamp Hose
42	810 04 07-00	Washer, Lock 7/16
45	873 51 04-00	Nut Keps Hex 1/4-20 unc
69	532 16 52-91	Gasket
79	532 19 23-34	Screw 5/16-18 x .75
81	532 14 84-56	Tube Drain Oil Easy
82	532 42 82-87	Valve Oil Drain
84	817 06 06-20	Screw 3/8-16 x 1-1/4
85	532 17 39-37	Bolt Hex 7/16-20 x 4 Gr. 5 - 1.5
87	532 17 18-77	Bolt 5/16-18 unc x 3/4
90	817 00 06-16	Screw 3/8-16 x 1
94	581 88 09-01	Tube Exhaust
96	819 09 14-16	Washer 9/32 x 7/8 x 16 Ga.
97	817 67 04-12	Screw 1/4-20 x 3/4

**NOTE:** All component dimensions given in U.S. inches  
1 inch = 25.4 mm

**Engine Power Rating Information**

The gross power rating for individual gas engine models is labeled in accordance with SAE (Society of Automotive Engineers) code J1940 (Small Engine Power & Torque Rating Procedure), and rating performance has been obtained and corrected in accordance with SAE J1995 (Revision 2002-05). Torque values are derived at 3060 RPM; horsepower values are derived at 3600 RPM. Actual gross engine power will be lower and is affected by, among other things, ambient operating conditions and engine-to-engine variability. Given both the wide array of products on which engines are placed and the variety of environmental issues applicable to operating the equipment, the gas engine will not develop the rated gross power when used in a given piece of power equipment (actual “on-site” or net power). This difference is due to a variety of factors including, but not limited to, accessories (air cleaner, exhaust, charging, cooling, carburetor, fuel pump, etc.), application limitations, ambient operating conditions (temperature, humidity, altitude), and engine-to-engine variability. Due to manufacturing and capacity limitations, Briggs & Stratton may substitute an engine of higher rated power for this Series engine.

TRACTOR - - MODEL NO. LTH2038R (96041028302), PRODUCT NO. 960 41 02-83  
STEERING ASSEMBLY **41**

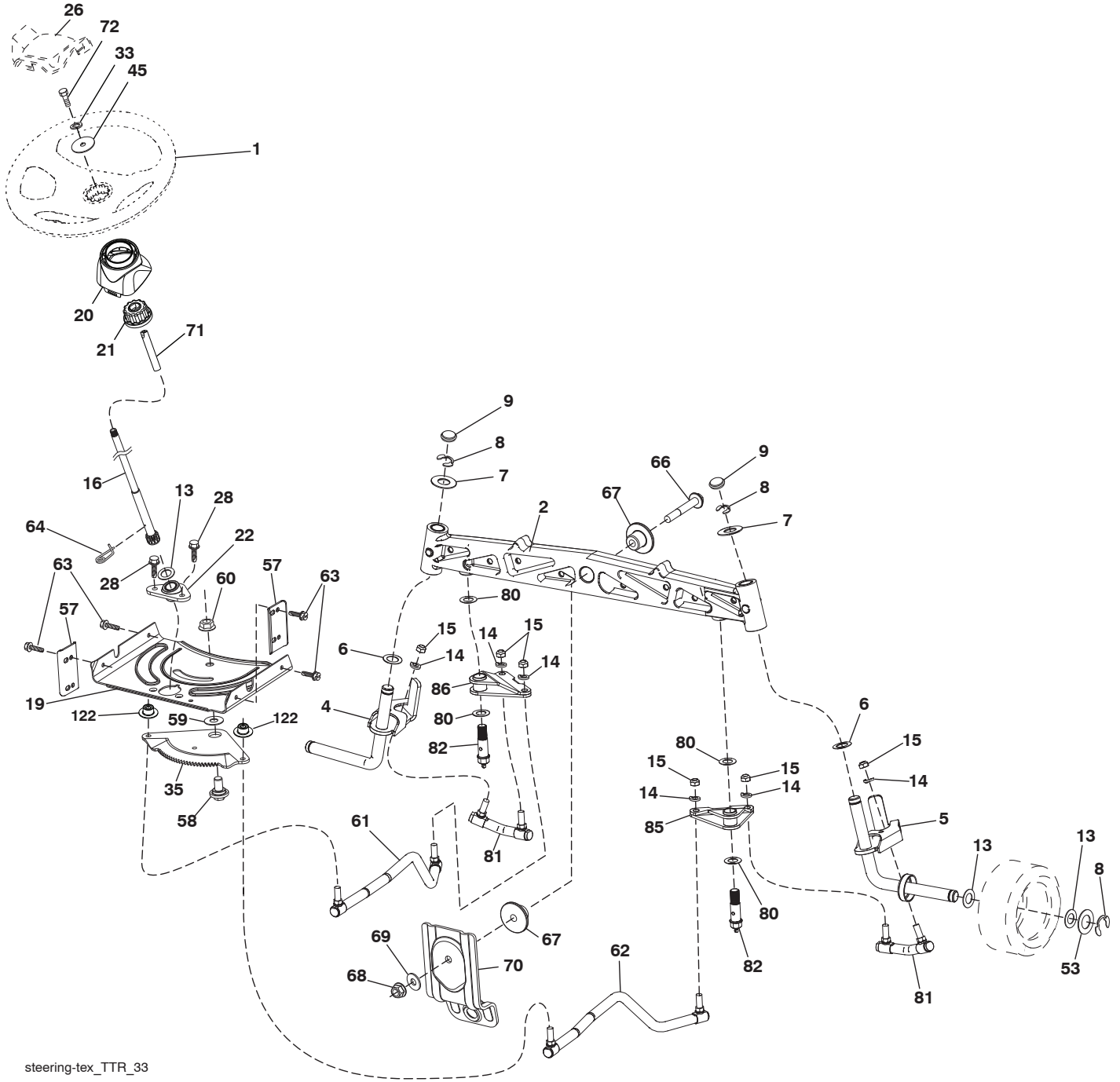

steering-tex\_TTR\_33

**TRACTOR - - MODEL NO. LTH2038R (96041028302), PRODUCT NO. 960 41 02-83  
STEERING ASSEMBLY 41**

<b>KEY NO.</b>	<b>PART NO.</b>	<b>DESCRIPTION</b>
1	532 43 97-40	Wheel, Steering
2	532 43 68-70	Axle Asm., Front
4	532 43 68-73	Spindle Asm., LH
5	532 43 68-74	Spindle Asm., RH
6	532 12 49-31	Washer Thrust 0.75 x 1.23
7	532 12 17-48	Washer 25/32 x 1-5/8 x 16 Ga.
8	812 00 00-29	Ring, Klip #T5304-75
9	532 12 12-32	Cap, Spindle
13	532 12 17-49	Washer 25/32 x 1-1/4 x 16 Ga.
14	810 04 06-00	Washer, Lock 3/8
15	873 54 06-00	Nut, Crown Lock 3/8-24 unf
16	532 44 42-13	Shaft Steering
19	532 19 47-29	Plate Steering
20	532 44 14-25	Boot, Steering
21	532 43 77-47	Adapter, Wheel Steering
22	532 19 48-45	Bushing, Strg. Blk
26	532 43 97-43	Insert, Wheel Steering
28	817 00 06-12	Screw 3/8-16 x 3/4
33	810 04 05-00	Washer 5/16
35	532 44 07-70	Gear, Sector Plate
45	819 11 38-12	Washer 11/32 ID x 2-3/8 OD x 12 Ga.
53	532 18 89-67	Washer Hardened .793 x 1.637 x .060
57	532 40 74-65	Bracket Upstop
58	532 19 47-47	Bolt Shoulder Sector Pivot CFM
59	532 19 47-48	Washer Thrust Sector Steering
60	873 97 10-00	Nut Flange Lock 5/8-11
61	532 43 68-84	Draglink, LH
62	532 43 68-85	Draglink, RH
63	817 00 05-12	Screw 5/16-18 x 3/4
64	532 19 98-49	Retainer Clip Spring Steering
66	871 02 07-48	Bolt Hex Fghd 7/16-14 x 3 Serr
67	532 19 47-37	Bushing PM Front Axle
68	873 90 07-00	Nut Lock Flange 7/16-14 Gr. 5
69	532 19 91-62	Washer 1.5 x .505 x .118
70	585 33 88-01	Bracket Deck Susp. Front
71	532 19 07-52	Shaft Extension
72	532 42 89-82	Bolt 5/16-18 x 4
80	532 00 13-70	Washer
81	532 43 68-87	Link Cross RH
82	532 44 21-47	Pivot Bolt
85	532 44 18-73	Pivot RH
86	532 44 18-72	Pivot LH
122	532 44 49-62	Cap Gear

**NOTE:** All component dimensions given in U.S. inches  
1 inch = 25.4 mm

TRACTOR - - MODEL NO. LTH2038R (96041028302), PRODUCT NO. 960 41 02-83  
MOWER DECK 44

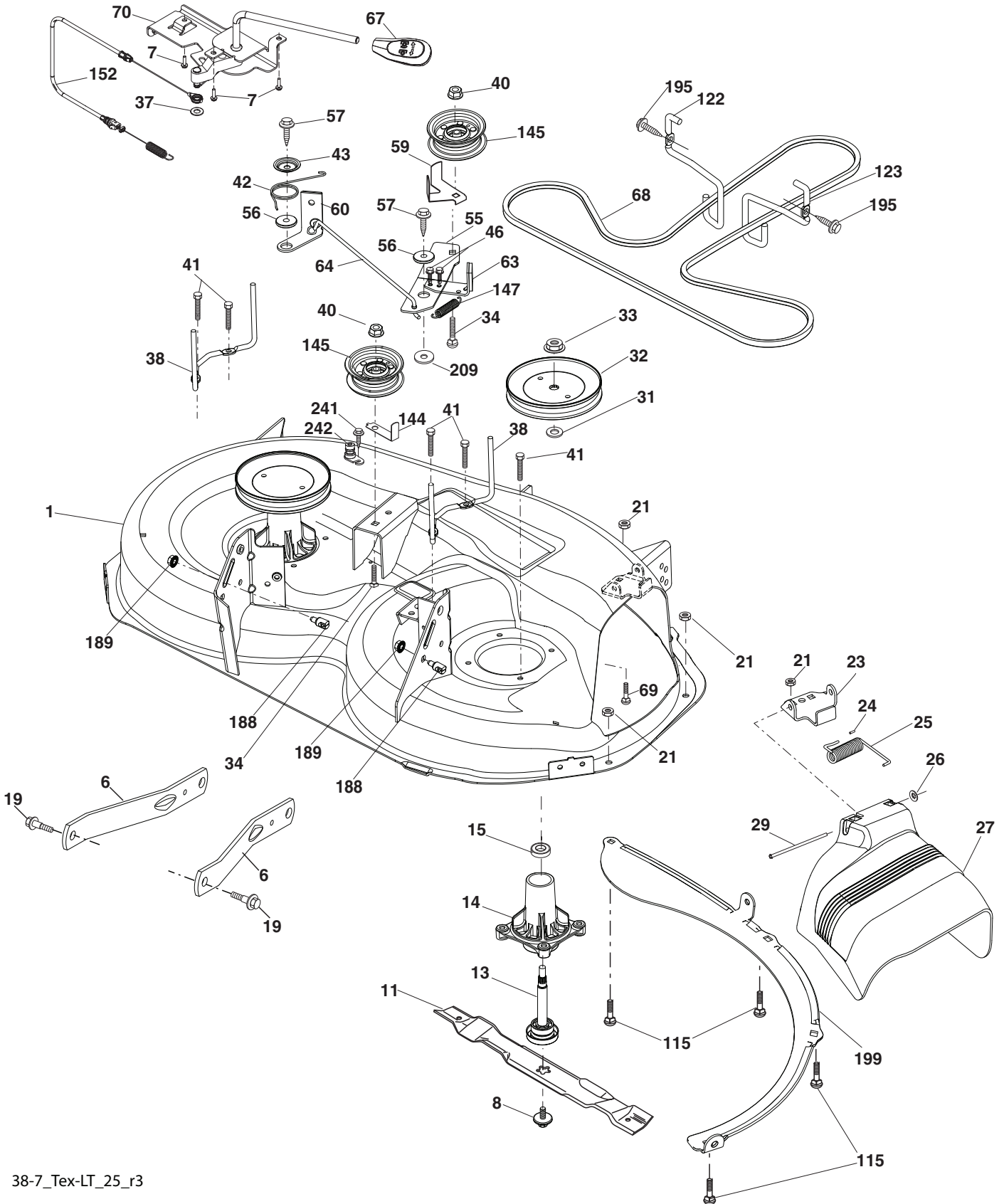

38-7\_Tex-LT\_25\_r3

**TRACTOR - - MODEL NO. LTH2038R (96041028302), PRODUCT NO. 960 41 02-83  
MOWER DECK 44**

KEY NO.	PART NO.	DESCRIPTION	KEY NO.	PART NO.	DESCRIPTION
1	532 44 41-63	Mower Housing	60	532 19 94-71	Arm Brake Mower
6	532 19 51-86	Arm Suspension	63	532 19 94-70	Arm Brake Mower
7	532 41 63-58	Screw #10 x 0.750 BOS Thread	64	532 19 97-90	Link Brake
8	532 19 30-03	Bolt/Washer Asm 7/16-20 unf	67	532 40 30-12	Handle Clutch Cable
11	532 19 39-57	Blade	68	532 40 83-81	V-Belt
13	532 19 28-72	Shaft Assembly, Mandrel	69	872 14 05-05	Bolt
14	532 18 72-81	Housing, Mandrel	70	532 40 12-46	Clutch Asm Manual
15	532 11 04-85	Bearing, Ball, Mandrel	115	872 11 05-05	Bolt Carr. 5/16-18 x 5/8 Short
19	532 19 65-39	Bolt, Shoulder	122	532 19 72-58	Keeper Belt Engine LH
21	873 68 05-00	Nut, Crownlock 5/16-18 unc	123	532 19 72-59	Keeper Belt Engine RH
23	532 19 25-57	Bracket, Deflector	144	532 19 34-14	Keeper Belt
24	532 10 53-04	Cap, Sleeve	145	532 19 31-97	Pulley, Idler, Flat
25	532 19 70-26	Spring, Torsion, Deflector	147	532 40 18-72	Spring Return
26	532 11 04-52	Nut, Push	152	532 43 51-11	Manual Clutch Cable
27	532 19 39-68	Shield, Deflector	188	532 19 51-61	Stud Fastener
29	532 13 14-91	Rod, Hinge	189	873 90 05-00	Nut Lock Hex Flange
31	532 18 76-90	Washer, Spacer	195	817 00 06-12	Screw 3/8-16 x 3/4
32	532 19 97-89	Pulley, Mandrel	199	532 40 00-95	Baffle Vortex
33	532 40 02-34	Nut, Toplock, Flanged	209	819 13 32-10	Washer 13/32 x 2 x 10
34	872 11 06-12	Bolt Carr Sh. 3/8-16 x 1-1/2 Gr. 5	241	532 15 29-27	Screw TT #10-32.5.3/8 Flange
37	819 13 13-16	Washer	242	532 41 55-98	Port Washout
38	532 19 95-41	Keeper Belt LH Mandrel	--	532 19 28-70	Mandrel Assembly (Includes housing (key #14), shaft assembly (key #13), and bearing (key #15) only - pulley/nut/washer and blade bolt/washers not included)
40	873 90 06-00	Nut, Lock Fig. 3/8-16 unc	--	532 43 44-67	Replacement Mower, Complete
41	584 95 39-01	Bolt Hex Wsh Hd .313-18 x 1.19			
42	532 19 84-10	Spring Torsion Brake			
43	532 19 72-56	Spring Torsion Retainer			
46	532 13 77-29	Screw 1/4-20 x 5/8			
55	532 19 72-49	Arm, Idler			
56	532 19 90-92	Spacer, Retainer			
57	817 00 06-16	Screw 3/8-16 x 1			
59	532 14 10-43	Guard, Tuv Idler			

**NOTE:** All component dimensions given in U.S. inches  
1 inch = 25.4 mm

TRACTOR - - MODEL NO. LTH2038R (96041028302), PRODUCT NO. 960 41 02-83  
 MOWER LIFT **45**

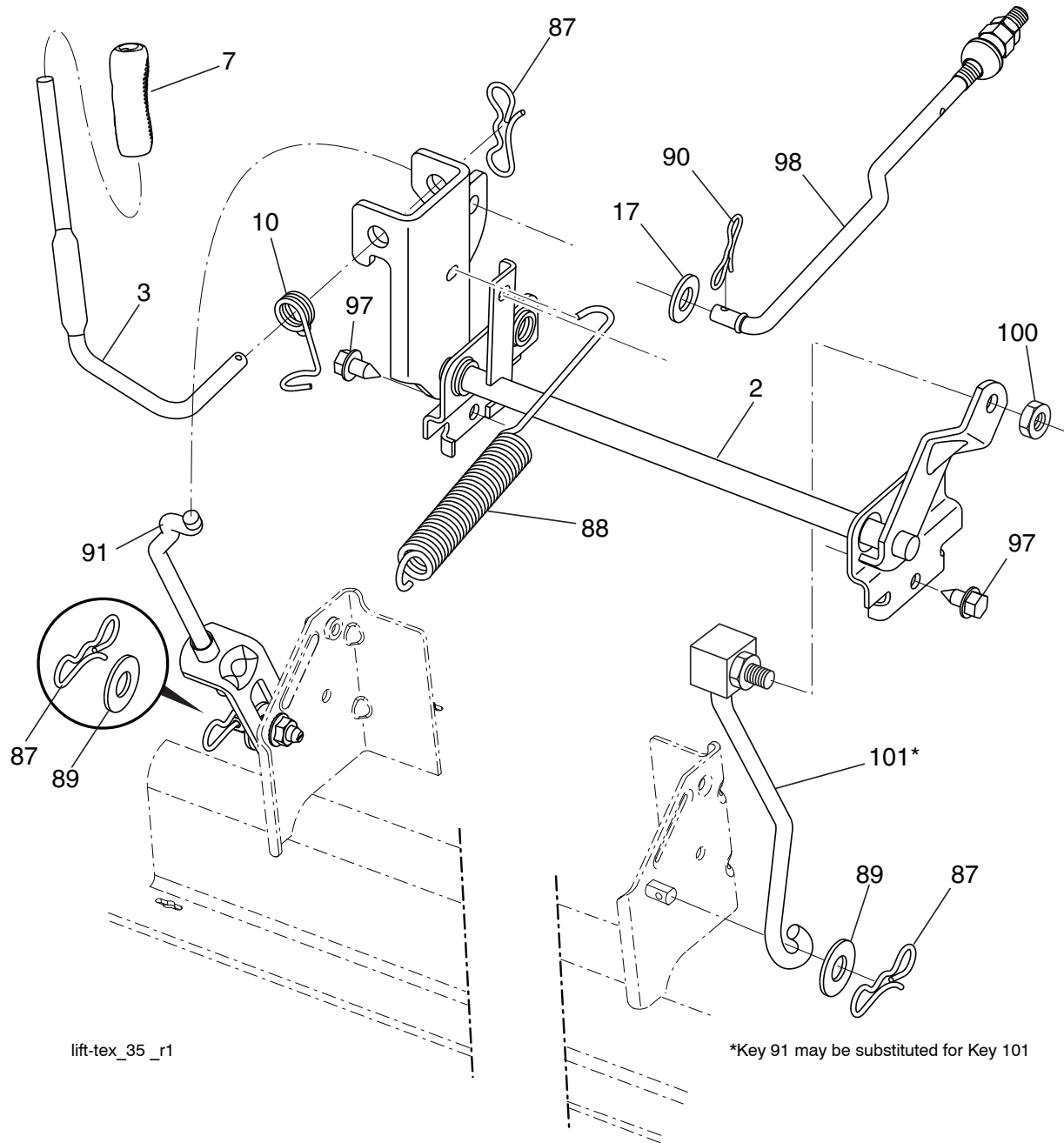

KEY NO.	PART NO.	DESCRIPTION
2	532 42 20-27	Shaft Asm., Lift
3	532 19 52-31	Lever Asm., Lift RH
7	580 96 23-01	Grip, Lever
10	532 19 63-14	Spring Torsion
17	819 13 13-12	Washer 13/32 x 13/16 x 12 Ga.
87	532 19 42-09	Pin Cotter 7/16 Bow Tie Lock
88	532 41 07-10	Spring Lift Assist
89	819 19 19-12	Washer Clear Zinc
90	532 19 42-08	Pin Cotter 5/16 Bow Tie Lock

KEY NO.	PART NO.	DESCRIPTION
91	532 19 51-81	Link Lift Susp Mower Rear
97	817 00 06-12	Screw 3/8-16 x .75 Smgml Tap/R.Z
98	532 19 52-70	Link Lift Susp. Front Mower
100	873 93 06-00	Nut Centerlock 3/8-16
101	532 40 70-03	Link Asm. Lift FXD

**NOTE:** All component dimensions given in U.S. inches  
 1 inch = 25.4 mm



**TRACTOR - - MODEL NO. LTH2038R (96041028302), PRODUCT NO. 960 41 02-83  
SEAT ASSEMBLY 42**

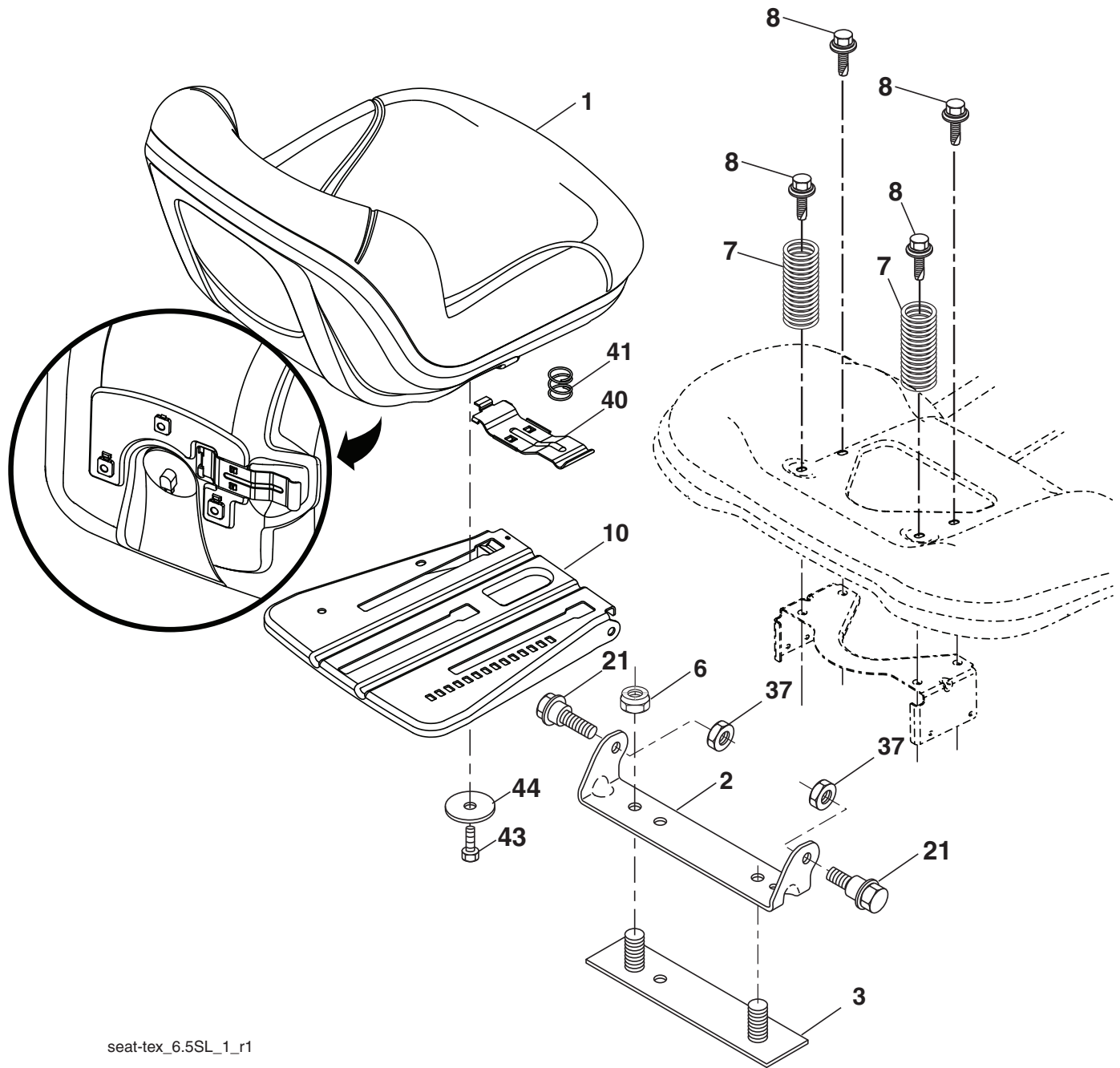

seat-tex\_6.5SL\_1\_r1

KEY NO.	PART NO.	DESCRIPTION
1	532 43 98-22	Seat
2	532 18 01-66	Bracket Pivot Fender
3	532 14 06-75	Strap, Asm Fender
6	873 80 06-00	Nut, Lock w/Ins. 3/8-16 unc
7	532 12 41-81	Spring, Seat Cprsn
8	532 17 18-77	Bolt 5/16-18 unc x 3/4 w/Sems
10	532 19 69-77	Pan, Seat
21	532 17 18-52	Bolt, Shoulder 5/16-18

KEY NO.	PART NO.	DESCRIPTION
37	873 80 05-00	Nut, Lock 5/16-18 unc
40	532 19 76-61	Handle Slide Seat
41	532 19 82-00	Spring Latch Seat
43	874 76 06-12	Bolt Fin Hex 3/8-16 x 3/4
44	819 13 38-12	Washer 13/32 x 2-3/8 x 12 Ga.

**NOTE:** All component dimensions given in U.S. inches  
1 inch = 25.4 mm

