

ILLUSTRATED PARTS LIST

MODEL NUMBER ST 261E
PRODUCT NUMBER 961 91 00-30
MFG. ID. NUMBER 96191003011

REPAIR PARTS

AUGER HOUSING / IMPELLER ASSEMBLY

SNOW THROWER - MODEL NO. **ST 261E** (96191003011), PRODUCT NO. 961 91 00-30

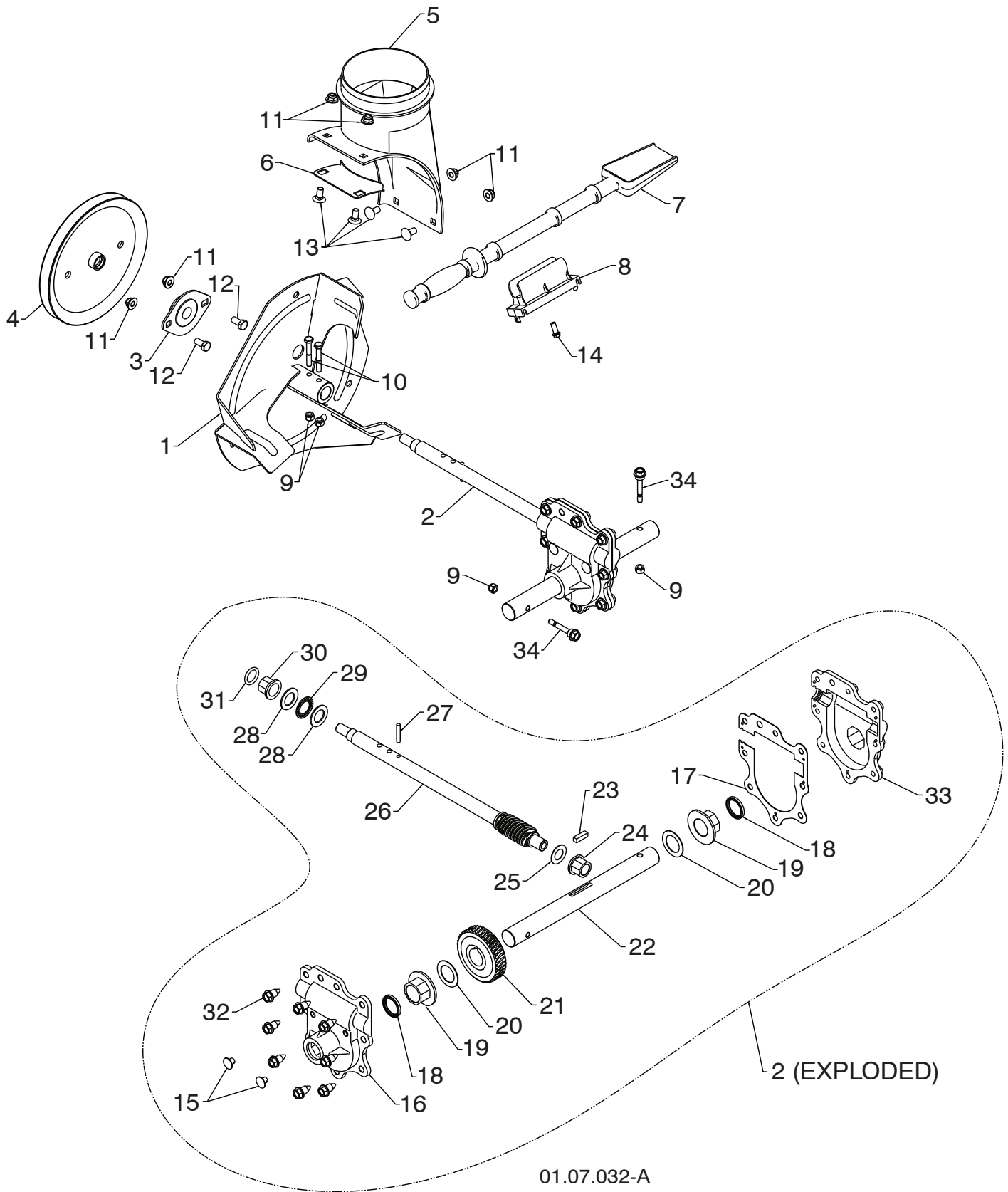

NOTE: All component dimensions given in U.S. inches. 1 inch = 25.4 mm
IMPORTANT: Use only Original Equipment Manufacturer (O.E.M.) replacement parts.
Failure to do so could be hazardous, damage your snow thrower and void your warranty.

REPAIR PARTS

AUGER HOUSING / IMPELLER ASSEMBLY

SNOW THROWER - MODEL NO. **ST 261E** (96191003011), PRODUCT NO. 961 91 00-30

KEY NO.	PART NO.	DESCRIPTION
1	532 18 41-05	IMPELLER
2	584 64 83-01	GEARBOX ASSEMBLY
3	532 18 89-09	BEARING
4	585 09 32-01	IMPELLER PULLEY
5	585 05 69-01	DISCHARGE BASE
6	532 18 40-95	CORNER BRACKET
7	532 19 21-99	CLEAN OUT TOOL
8	532 40 54-00	TOOL CLIP
9	873 80 04-00	NUT 1/4-20
10	874 78 04-26	SCREW 1/4-20 X .625
11	532 42 79-42	NUT 5/16-18
12	532 16 31-83	SCREW 5/16-18 X .625
13	532 18 03-55	CARRIAGE BOLT
14	532 19 41-89	SCREW 13-16 X .625
15	532 40 77-60	PLUG
16	532 42 73-02	GEARBOX COVER RH
17	532 42 73-45	GASKET
18	532 40 77-70	SEAL
19	532 40 77-62	BEARING
20	532 17 46-97	THRUST WASHER 1.00
21	580 36 41-01	WORM GEAR
22	532 40 77-64	AUGER SHAFT
23	532 18 92-82	SQUARE KEY
24	532 40 77-58	BEARING
25	532 17 46-83	THRUST WASHER
26	584 64 84-01	IMPELLER SHAFT
27	532 18 42-05	ROLL PIN
28	532 17 46-81	THRUST WASHER
29	532 17 46-84	THRUST BEARING
30	532 40 77-69	BEARING
31	532 40 77-68	O-RING
32	532 40 77-67	SCREW 5/16-18 X .750
33	532 42 73-17	GEARBOX COVER LH
34	532 19 20-90	SHEAR BOLT

NOTE: All component dimensions given in U.S. inches. 1 inch = 25.4 mm

IMPORTANT: Use only Original Equipment Manufacturer (O.E.M.) replacement parts. Failure to do so could be hazardous, damage your snow thrower and void your warranty.

REPAIR PARTS

AUGER HOUSING / IMPELLER ASSEMBLY

SNOW THROWER - MODEL NO. **ST 261E** (96191003011), PRODUCT NO. 961 91 00-30

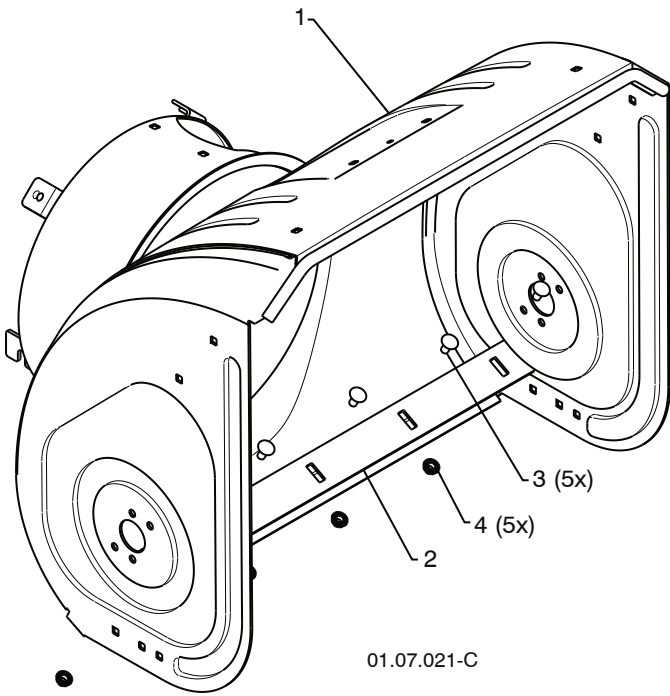

01.07.021-C

KEY NO.	PART NO.	DESCRIPTION
1	532 42 93-45	AUGER HOUSING
2	532 40 78-25	SCRAPER BAR
3	872 27 05-05	CARRIAGE BOLT 5/16-18 X .625
4	532 15 53-77	NUT 5/16-18



01.07.014-A

KEY NO.	PART NO.	DESCRIPTION
1	532 42 21-03	AUGER ASSEMBLY 24 LH
2	532 42 21-04	AUGER ASSEMBLY 24 RH

NOTE: All component dimensions given in U.S. inches. 1 inch = 25.4 mm
IMPORTANT: Use only Original Equipment Manufacturer (O.E.M.) replacement parts.
 Failure to do so could be hazardous, damage your snow thrower and void your warranty.

REPAIR PARTS

AUGER HOUSING / IMPELLER ASSEMBLY

SNOW THROWER - MODEL NO. **ST 261E** (96191003011), PRODUCT NO. 961 91 00-30

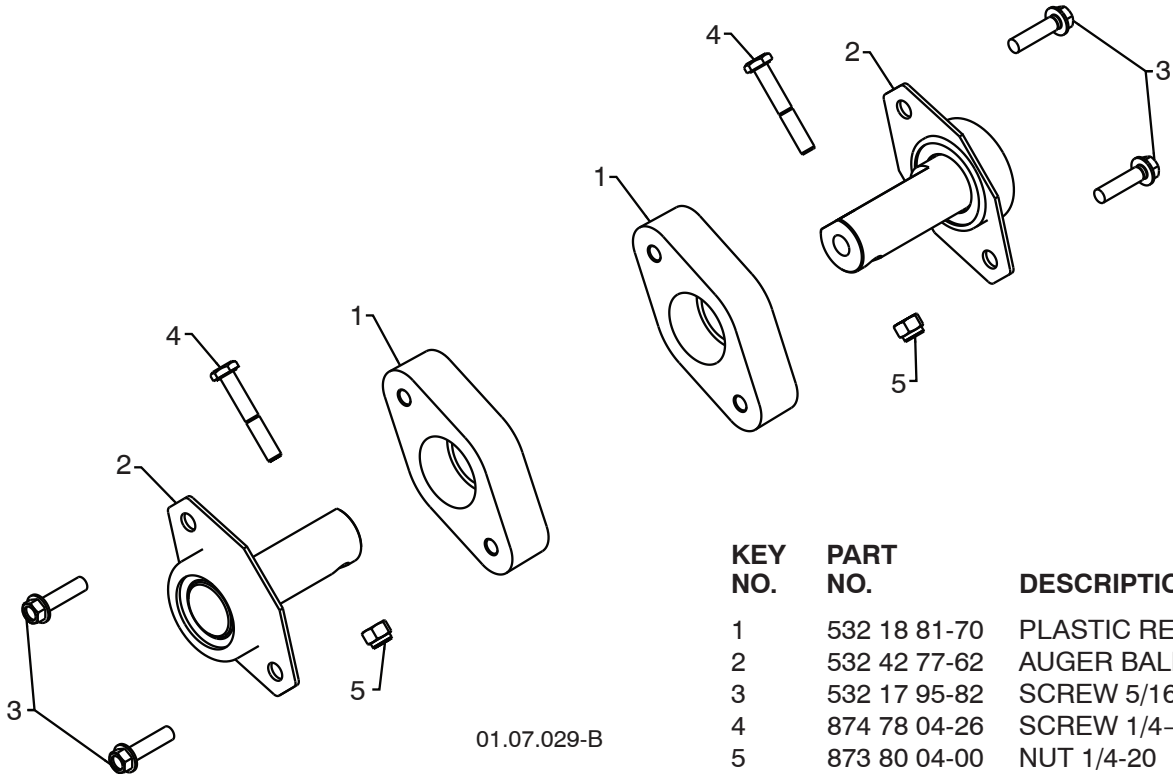

01.07.029-B

KEY NO.	PART NO.	DESCRIPTION
1	532 18 81-70	PLASTIC RETAINER
2	532 42 77-62	AUGER BALL BEARING
3	532 17 95-82	SCREW 5/16-18 X 1.00
4	874 78 04-26	SCREW 1/4-20 X .625
5	873 80 04-00	NUT 1/4-20

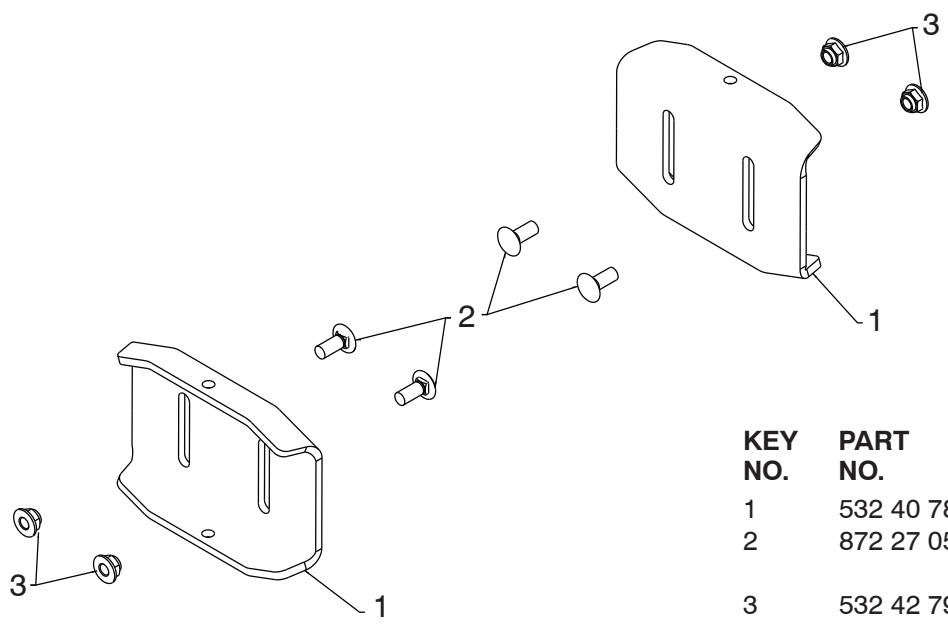

01.11.002-C

KEY NO.	PART NO.	DESCRIPTION
1	532 40 78-34	SKID PLATE
2	872 27 05-06	CARRIAGE BOLT 5/16-18 X .750
3	532 42 79-42	NUT 5/16-18

NOTE: All component dimensions given in U.S. inches. 1 inch = 25.4 mm
IMPORTANT: Use only Original Equipment Manufacturer (O.E.M.) replacement parts. Failure to do so could be hazardous, damage your snow thrower and void your warranty.

REPAIR PARTS

AUGER HOUSING / IMPELLER ASSEMBLY

SNOW THROWER - MODEL NO. **ST 261E** (96191003011), PRODUCT NO. 961 91 00-30

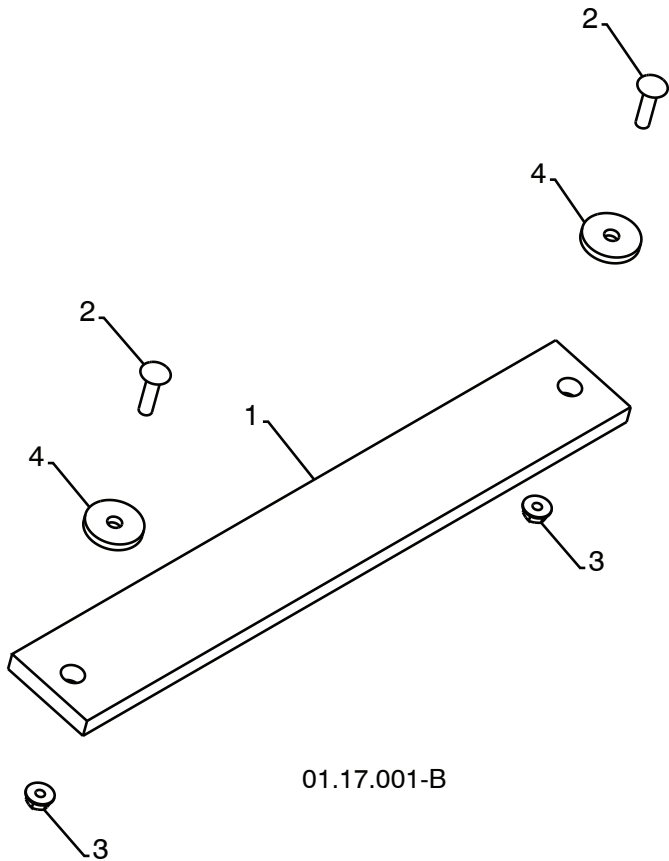

KEY NO.	PART NO.	DESCRIPTION
1	532 18 25-13	WEIGHT BAR
2	872 11 05-10	CARRIAGE BOLT 5/16-18 X 1.25
3	532 75 11-53	NUT 5/16-18
4	819 11 22-06	WASHER

01.17.001-B

NOTE: All component dimensions given in U.S. inches. 1 inch = 25.4 mm
IMPORTANT: Use only Original Equipment Manufacturer (O.E.M.) replacement parts.
Failure to do so could be hazardous, damage your snow thrower and void your warranty.

REPAIR PARTS

CONTROL PANEL / DISCHARGE CHUTE

SNOW THROWER - MODEL NO. **ST 261E** (96191003011), PRODUCT NO. 961 91 00-30

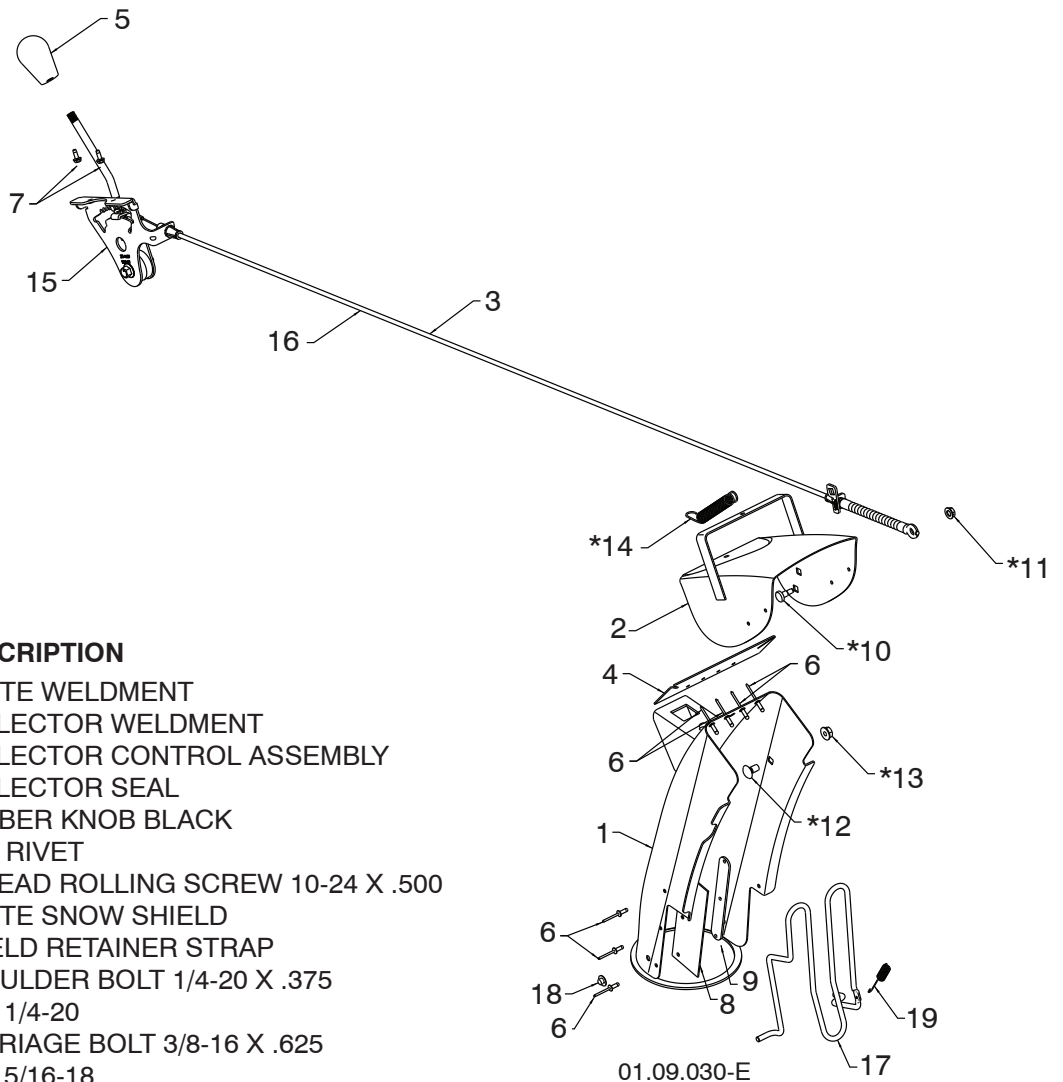

KEY NO.	PART NO.	DESCRIPTION
1	532 44 40-41	CHUTE WELDMENT
2	532 18 41-13	DEFLECTOR WELDMENT
3	587 03 08-01	DEFLECTOR CONTROL ASSEMBLY
4	532 42 03-25	DEFLECTOR SEAL
5	580 67 32-01	RUBBER KNOB BLACK
6	532 12 84-15	POP RIVET
7	817 54 10-08	THREAD ROLLING SCREW 10-24 X .500
8	532 43 03-24	CHUTE SNOW SHIELD
9	532 42 17-28	SHIELD RETAINER STRAP
*10	532 17 98-29	SHOULDER BOLT 1/4-20 X .375
*11	532 19 17-30	NUT 1/4-20
*12	585 83 20-01	CARRIAGE BOLT 3/8-16 X .625
*13	532 75 11-53	NUT 5/16-18
*14	532 18 45-05	DEFLECTOR SPRING
15	532 42 06-79	(SERVICE PART) DEFLECTOR CONTROL
16	587 03 09-01	(SERVICE PART) DEFLECTOR CABLE BLACK
17	532 43 55-82	CHUTE GUARD
18	532 05 93-49	PUSH NUT
19	532 43 56-16	SPRING

NOTE:

1. ALL ITEMS INDICATED WITH AN * ARE PROVIDED IN THE BAG OF ITEMS SHIPPED LOOSE WITH PRODUCT.
2. ITEMS 15 AND 16 ARE SERVICE PART NUMBERS TO ALLOW PURCHASE OF INDIVIDUAL ITEMS IF NECESSARY.

NOTE: All component dimensions given in U.S. inches. 1 inch = 25.4 mm
IMPORTANT: Use only Original Equipment Manufacturer (O.E.M.) replacement parts.
 Failure to do so could be hazardous, damage your snow thrower and void your warranty.

REPAIR PARTS

CONTROL PANEL / DISCHARGE CHUTE

SNOW THROWER - MODEL NO. **ST 261E** (96191003011), PRODUCT NO. 961 91 00-30

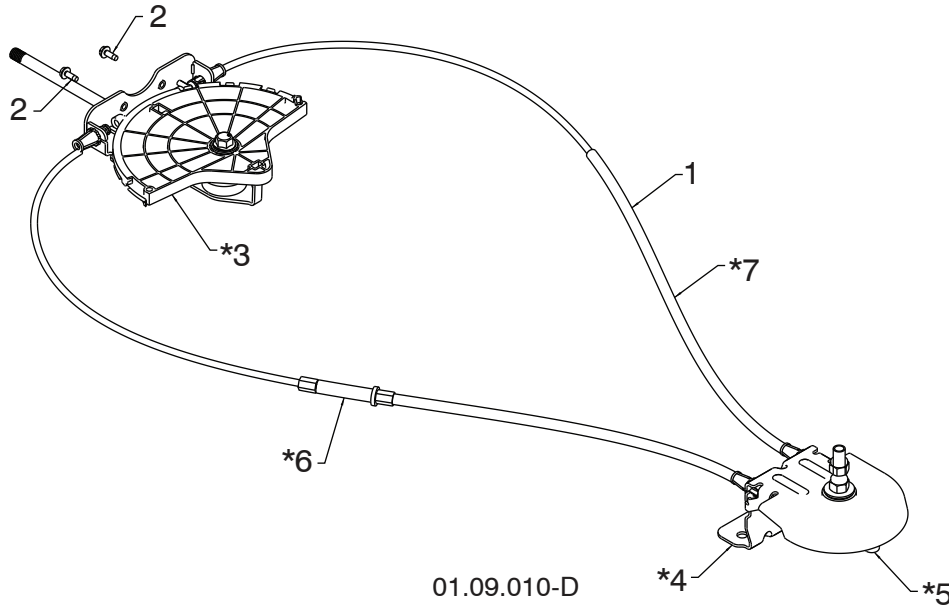

KEY NO.	PART NO.	DESCRIPTION
1	532 42 82-72	LEVER/CABLE ROTATOR ASSEMBLY
2	817 54 10-08	THREAD ROLLING SCREW 10-24 X .500
*3	532 42 06-78	ROTATOR HEAD
*4	585 19 92-01	ROTATOR PIVOT BRACKET
*5	532 42 06-75	PULLEY PIVOT
*6	532 42 82-73	CABLE ASSEMBLY ADJUSTABLE
*7	532 42 83-10	CABLE ASSEMBLY HEAT SHIELD

NOTES:

1. ITEMS INDICATED WITH AN * ARE LISTED AS REFERENCE FOR SERVICE PARTS ONLY.

NOTE: All component dimensions given in U.S. inches. 1 inch = 25.4 mm
IMPORTANT: Use only Original Equipment Manufacturer (O.E.M.) replacement parts. Failure to do so could be hazardous, damage your snow thrower and void your warranty.

REPAIR PARTS

CONTROL PANEL / DISCHARGE CHUTE

SNOW THROWER - MODEL NO. **ST 261E** (96191003011), PRODUCT NO. 961 91 00-30

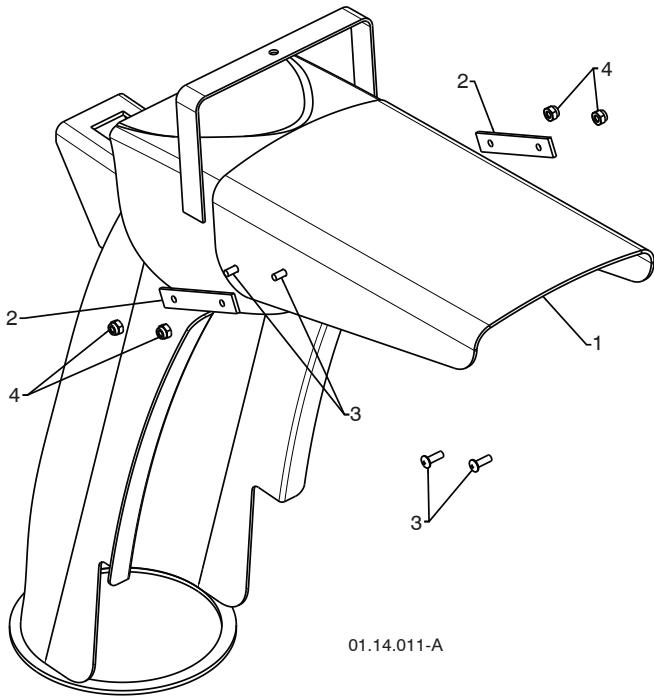

KEY NO.	PART NO.	DESCRIPTION
1	532 42 11-38	SHIELD DEFLECTOR
2	532 42 32-47	STRAP
3	532 18 22-27	SCREW 8-32 X .50
4	532 18 22-28	NUT 8-32

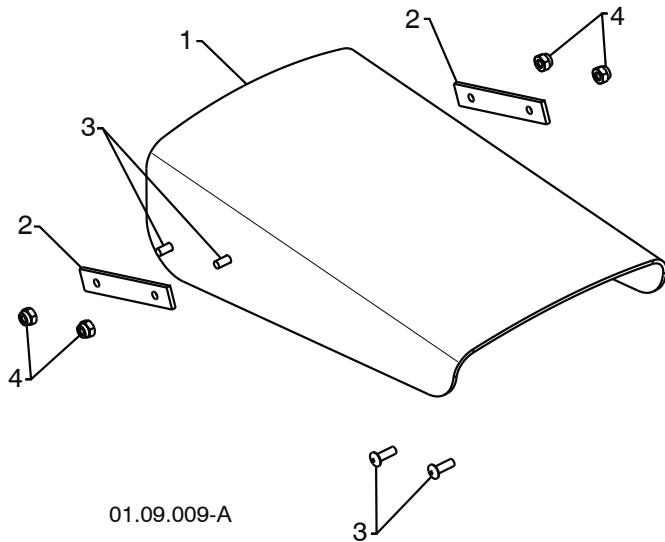

KEY NO.	PART NO.	DESCRIPTION
1	532 42 11-38	SHIELD DEFLECTOR
2	532 42 32-47	STRAP
3	532 18 22-27	SCREW 8-32 X .50
4	532 18 22-28	NUT 8-32

NOTE: All component dimensions given in U.S. inches. 1 inch = 25.4 mm
IMPORTANT: Use only Original Equipment Manufacturer (O.E.M.) replacement parts.
 Failure to do so could be hazardous, damage your snow thrower and void your warranty.

REPAIR PARTS

HANDLES

SNOW THROWER - MODEL NO. **ST 261E** (96191003011), PRODUCT NO. 961 91 00-30

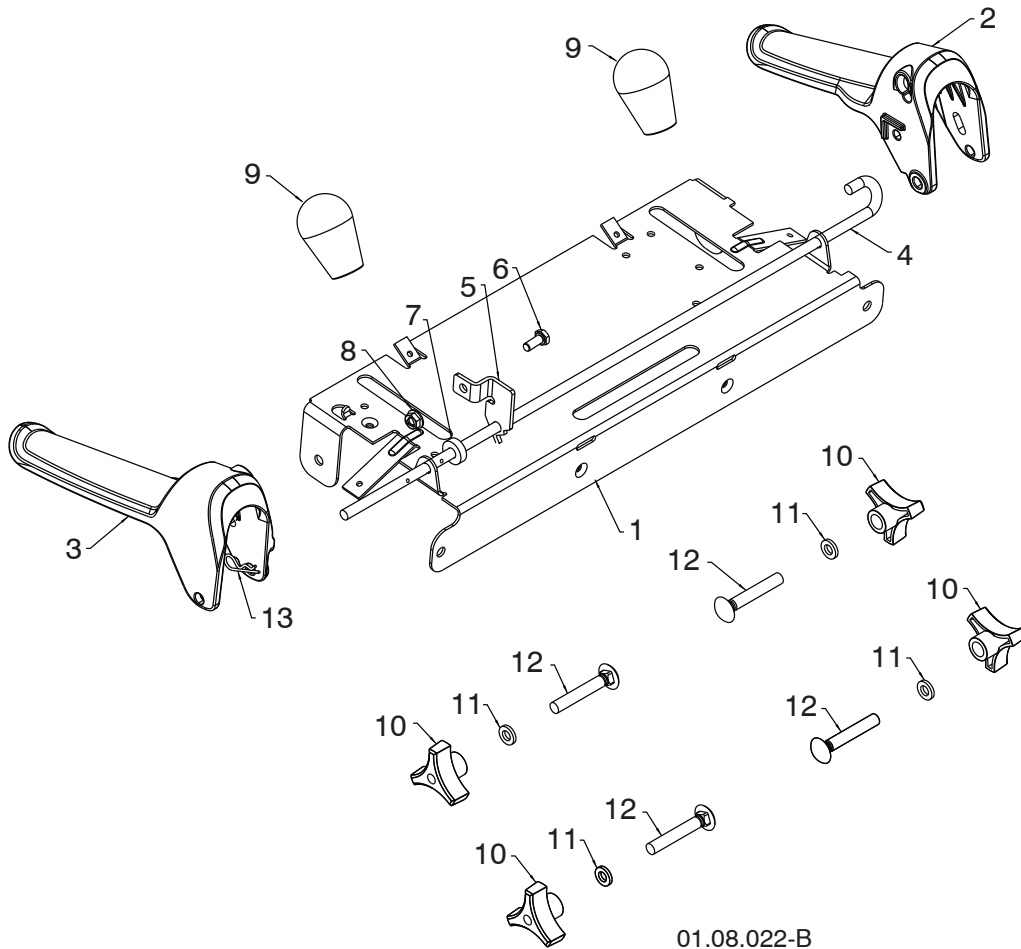

01.08.022-B

KEY NO.	PART NO.	DESCRIPTION
1	585 19 88-02	CONTROL PANEL
2	581 77 98-01	LH CONTROL LEVER
3	581 77 97-01	RH CONTROL LEVER
4	584 80 90-01	INTERLOCK CONTROL ROD
5	585 00 47-03	INTERLOCK BRACKET
6	874 78 04-10	1/4-20 X .625 HEX HEAD SCREW
7	532 42 16-13	SPACER
8	532 08 83-49	1/4-20 FLANGE NUT (TOP LOCK)
9	580 67 32-01	KNOB SOFT TOUCH
10	532 17 88-99	HANDLE KNOB
11	819 13 13-16	3/8 WASHER
12	872 12 06-18	CARRIAGE BOLT 3/8-16 X 2.25
13	532 16 96-75	RETAINER

NOTE: All component dimensions given in U.S. inches. 1 inch = 25.4 mm
IMPORTANT: Use only Original Equipment Manufacturer (O.E.M.) replacement parts. Failure to do so could be hazardous, damage your snow thrower and void your warranty.

REPAIR PARTS

HANDLES

SNOW THROWER - MODEL NO. **ST 261E** (96191003011), PRODUCT NO. 961 91 00-30

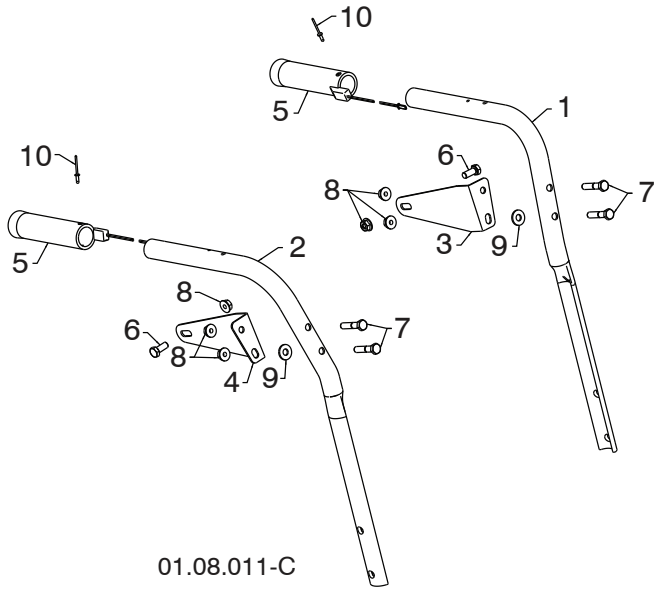

KEY NO.	PART NO.	DESCRIPTION
1	532 42 17-08	PLOW HANDLE LH
2	532 42 17-09	PLOW HANDLE RH
3	532 42 91-48	PANEL BRACKET LH
4	532 42 91-49	PANEL BRACKET RH
5	532 41 45-15	HEATED HANDLE GRIP
6	874 78 05-12	SCREW 5/16-18 X .750
7	874 78 05-24	SCREW 5/16-18 X 1.50
8	532 75 11-53	NUT 5/16-18
9	532 15 54-15	WASHER
10	532 17 87-75	POP RIVET 1/8

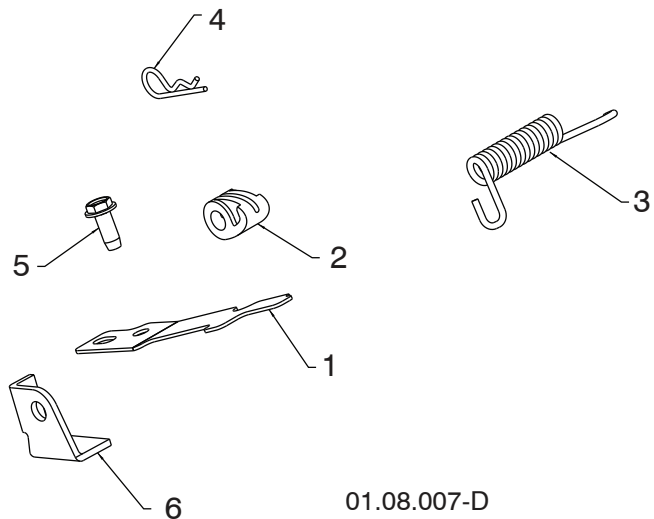

KEY NO.	PART NO.	DESCRIPTION
1	532 41 62-88	INTERLOCK SPRING
2	532 44 52-91	INTERLOCK CAM
3	532 44 32-15	TORSION SPRING
4	532 16 96-75	RETAINER
5	817 06 04-10	SCREW 1/4-20 X .625
6	532 42 18-14	INTERLOCK STOP

NOTE: All component dimensions given in U.S. inches. 1 inch = 25.4 mm
IMPORTANT: Use only Original Equipment Manufacturer (O.E.M.) replacement parts.
 Failure to do so could be hazardous, damage your snow thrower and void your warranty.

REPAIR PARTS

HANDLES

SNOW THROWER - MODEL NO. **ST 261E** (96191003011), PRODUCT NO. 961 91 00-30

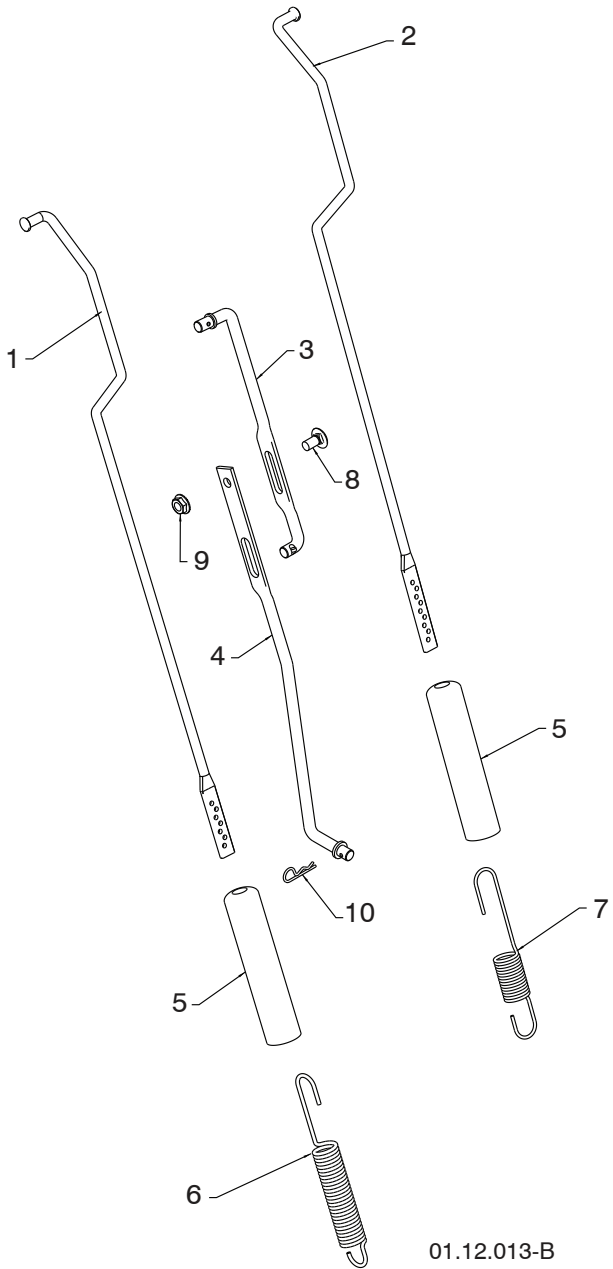

KEY NO.	PART NO.	DESCRIPTION
1	584 80 87-01	ROD IMPELLER CONTROL
2	584 80 88-01	ROD TRACTION CONTROL
3	532 18 04-45	SHIFTER ROD TOP
4	532 18 77-16	SHIFTER ROD BOTTOM
5	532 18 04-47	SPRING SLEEVE
6	580 79 62-01	SPRING CONTROL ROD
7	580 80 21-01	SPRING TRACTION ROD
8	872 27 05-05	CARRIAGE BOLT 5/16-18 X .75
9	532 15 53-77	NUT 5/16-18
10	532 16 96-75	RETAINER HAIRPIN

NOTE: HOOK TRACTION ROD SPRING IN HOLE 7
HOOK IMPELLER ROD SPRING IN HOLE 4

01.12.013-B

NOTE: All component dimensions given in U.S. inches. 1 inch = 25.4 mm
IMPORTANT: Use only Original Equipment Manufacturer (O.E.M.) replacement parts.
Failure to do so could be hazardous, damage your snow thrower and void your warranty.

REPAIR PARTS

HANDLES

SNOW THROWER - MODEL NO. **ST 261E** (96191003011), PRODUCT NO. 961 91 00-30

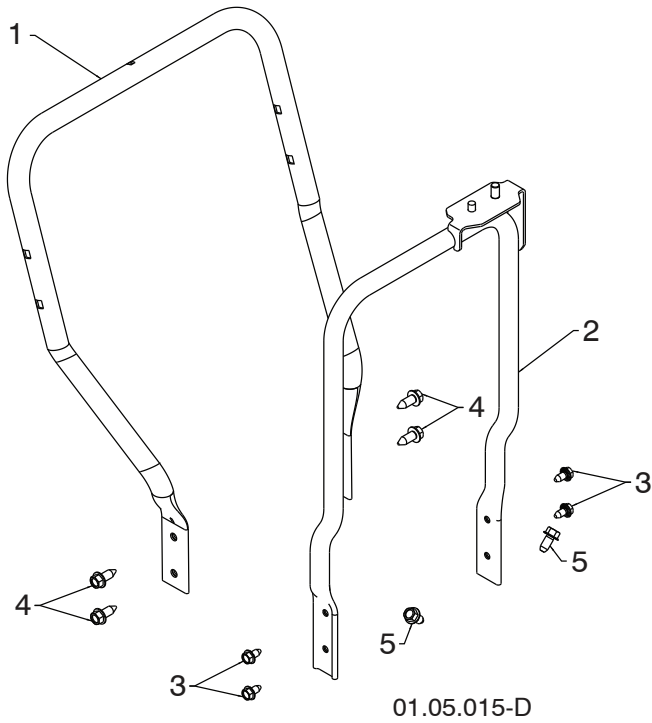

KEY NO.	PART NO.	DESCRIPTION
1	585 23 81-03	LOWER HANDLE
2	532 44 36-17	PIVOT SUPPORT WELDMENT
3	817 00 05-10	SCREW 5/16-18 X .750
4	817 00 06-16	SCREW 3/8-16 X 1.00
5	817 00 06-12	SCREW 3/8-16 X .750

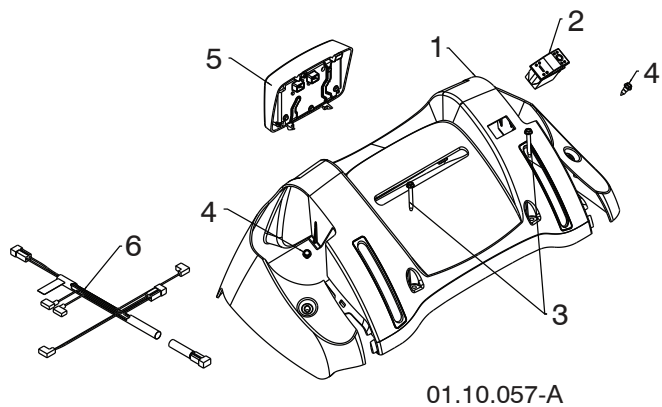

KEY NO.	PART NO.	DESCRIPTION
1	532 42 13-51	CONSOLE PANEL
2	532 41 77-60	SWITCH GRIP
3	532 17 52-62	SCREW HX WHSR HEAD 10-24 X 1.25
4	532 18 44-71	SCREW SHOULDER 10-24 X .62
5	581 68 42-01	LED LIGHT DUAL STAGE GRAY
6	580 62 56-01	WIRE HARNESS FLOOD / LED HEATED

NOTE: All component dimensions given in U.S. inches. 1 inch = 25.4 mm
IMPORTANT: Use only Original Equipment Manufacturer (O.E.M.) replacement parts.
 Failure to do so could be hazardous, damage your snow thrower and void your warranty.

REPAIR PARTS

DRIVE

SNOW THROWER - MODEL NO. ST 261E (96191003011), PRODUCT NO. 961 91 00-30

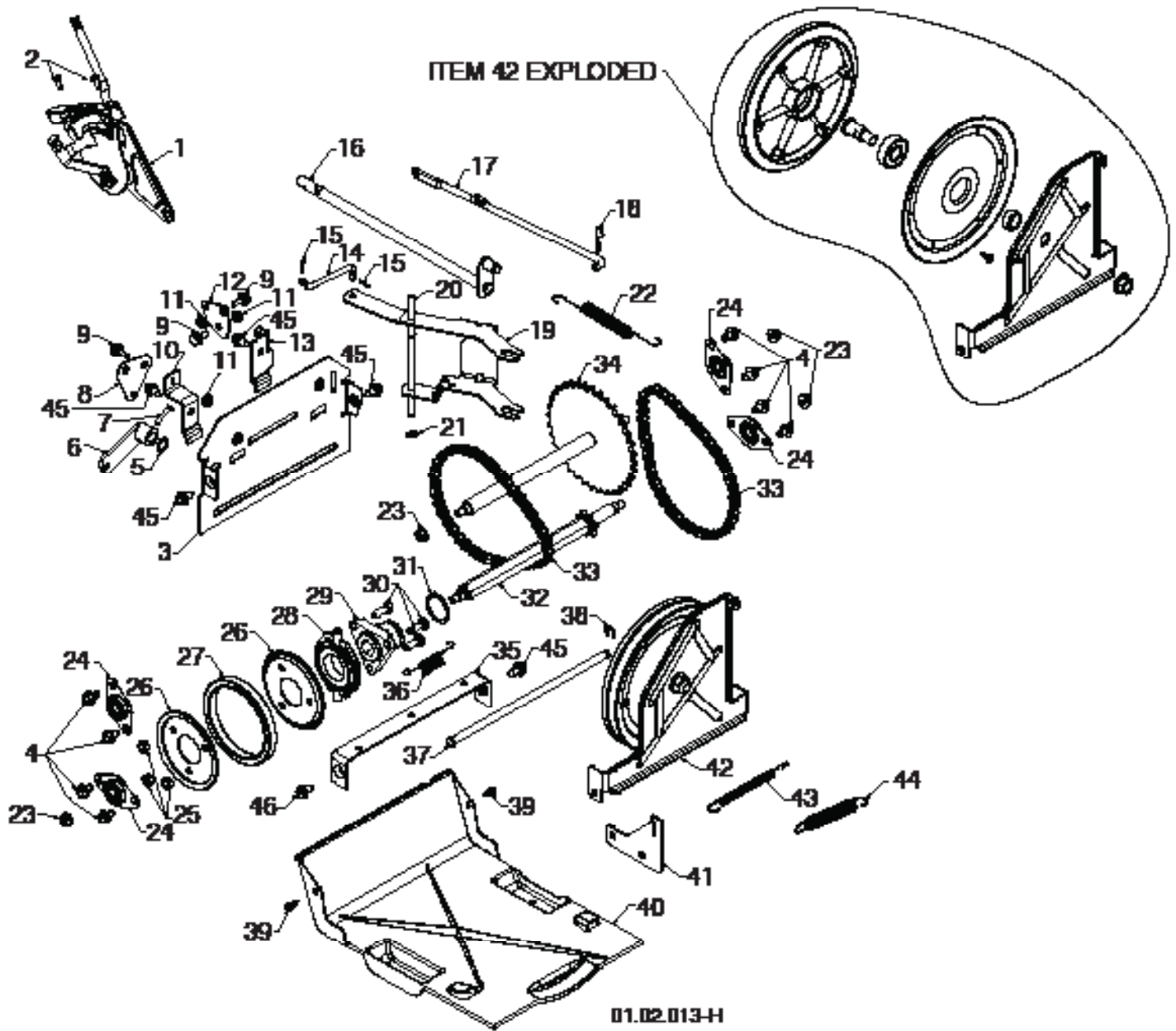

NOTE: All component dimensions given in U.S. inches. 1 inch = 25.4 mm
IMPORTANT: Use only Original Equipment Manufacturer (O.E.M.) replacement parts.
Failure to do so could be hazardous, damage your snow thrower and void your warranty.

REPAIR PARTS**DRIVE****SNOW THROWER - MODEL NO. ST 261E (96191003011), PRODUCT NO. 961 91 00-30**

KEY NO.	PART NO.	DESCRIPTION	KEY NO.	PART NO.	DESCRIPTION
1	532 19 88-75	SPEED SELECTOR ASSEMBLY	24	532 40 89-81	BEARING
2	817 54 10-08	THRED ROLLING SCREW 10-24 X .500	25	873 93 05-00	NUT 5/16-18
3	532 43 60-80	END PLATE	26	532 19 95-09	RUBBER WHEEL PLATE
4	817 49 05-08	SCREW 5/16-18 X .50	27	585 02 10-01	RUBBER RING
5	532 05 70-79	WASHER	28	532 17 53-44	BEARING
6	532 40 54-85	CONTROL ARM	29	532 17 86-13	WHEEL HUB
7	532 19 85-80	CLEVIS PIN	30	874 76 05-14	SCREW 5/16-18-.875
8	532 41 54-50	SHIFTER PLATE	31	812 00 00-12	RETAINER RING
9	532 40 28-81	SHOULDER BOLT	32	532 40 21-87	SPROCKET SHAFT
10	532 41 54-33	SHIFTER BRACKET	33	532 40 16-19	CHAIN
11	532 19 17-30	NUT 1/4-20	34	532 43 73-03	SPROCKET WELDMENT
12	532 41 54-35	CLUTCH PLATE	35	532 41 54-29	SHIFTER BRACKET
13	532 41 68-64	CLUTCH BRACKET	36	532 18 01-35	SPRING
14	532 18 71-01	SHIFTER LINK	37	532 40 26-52	PLATE PIVOT ROD
15	532 70 02-79	RETAINER	38	532 42 82-88	E-RING .375
16	532 42 75-42	CONTROL SHAFT	39	532 18 44-71	SHOULDER SCREW
17	532 40 25-68	CLUTCH ROD	40	532 41 08-77	BOTTOM PAN
18	532 16 96-75	RETAINER	41	532 41 66-82	SPRING BRACKET
19	581 42 25-01	SHIFTER YOKE	42	585 11 12-01	DRIVE PLATE ASSEMBLY
20	532 40 23-10	PIVOT ROD	43	532 41 45-57	IDLER SPRING
21	812 00 00-36	RETAINER	44	532 17 88-28	IDLER SPRING
22	532 40 28-78	RETURN SPRING	45	532 42 88-67	SCREW 5/16-18 X .750
23	532 75 11-53	NUT 5/16-18	46	817 00 05-10	BOLT 5/16-18 X .625

NOTE: All component dimensions given in U.S. inches. 1 inch = 25.4 mm**IMPORTANT:** Use only Original Equipment Manufacturer (O.E.M.) replacement parts. Failure to do so could be hazardous, damage your snow thrower and void your warranty.

REPAIR PARTS

DRIVE

SNOW THROWER - MODEL NO. **ST 261E** (96191003011), PRODUCT NO. 961 91 00-30

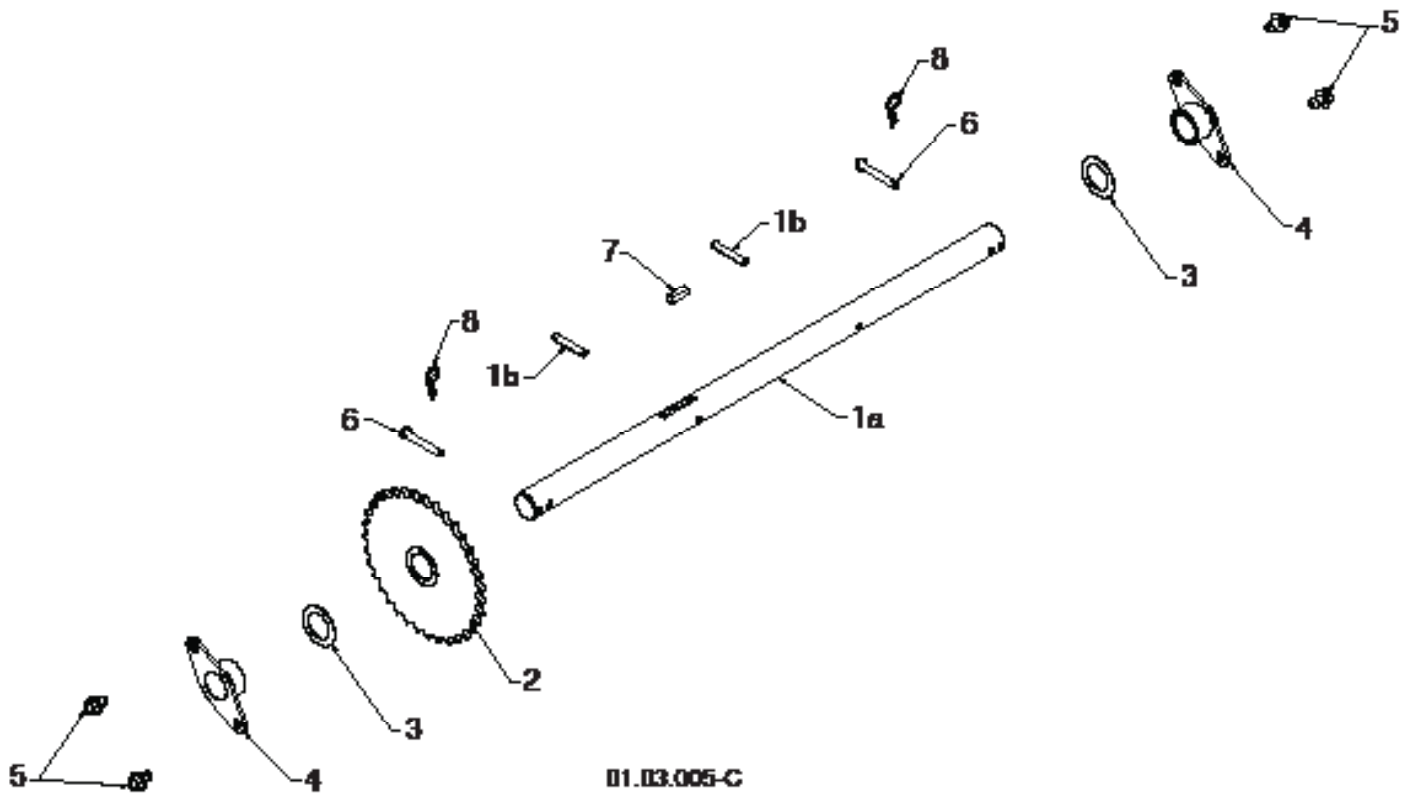

KEY NO.	PART NO.	DESCRIPTION
1	532 18 82-26	(assy of 1a,1b) AXLE ASSEMBLY
1a	532 17 93-52	AXLE SHAFT
1b	532 18 42-06	ROLL PIN 3/16
2	532 40 26-91	SPROCKET
3	532 44 49-49	THRUST WASHER
4	532 17 98-30	BEARING
5	817 49 05-08	BOLT 5/16-18 X .500
6	532 17 12-71	PIN
7	532 18 92-82	SQUARE KEY
8	532 12 47-88	RETAINER PIN

NOTE: All component dimensions given in U.S. inches. 1 inch = 25.4 mm
IMPORTANT: Use only Original Equipment Manufacturer (O.E.M.) replacement parts. Failure to do so could be hazardous, damage your snow thrower and void your warranty.

REPAIR PARTS

CHASSIS / PULLEYS

SNOW THROWER - MODEL NO. **ST 261E** (96191003011), PRODUCT NO. 961 91 00-30

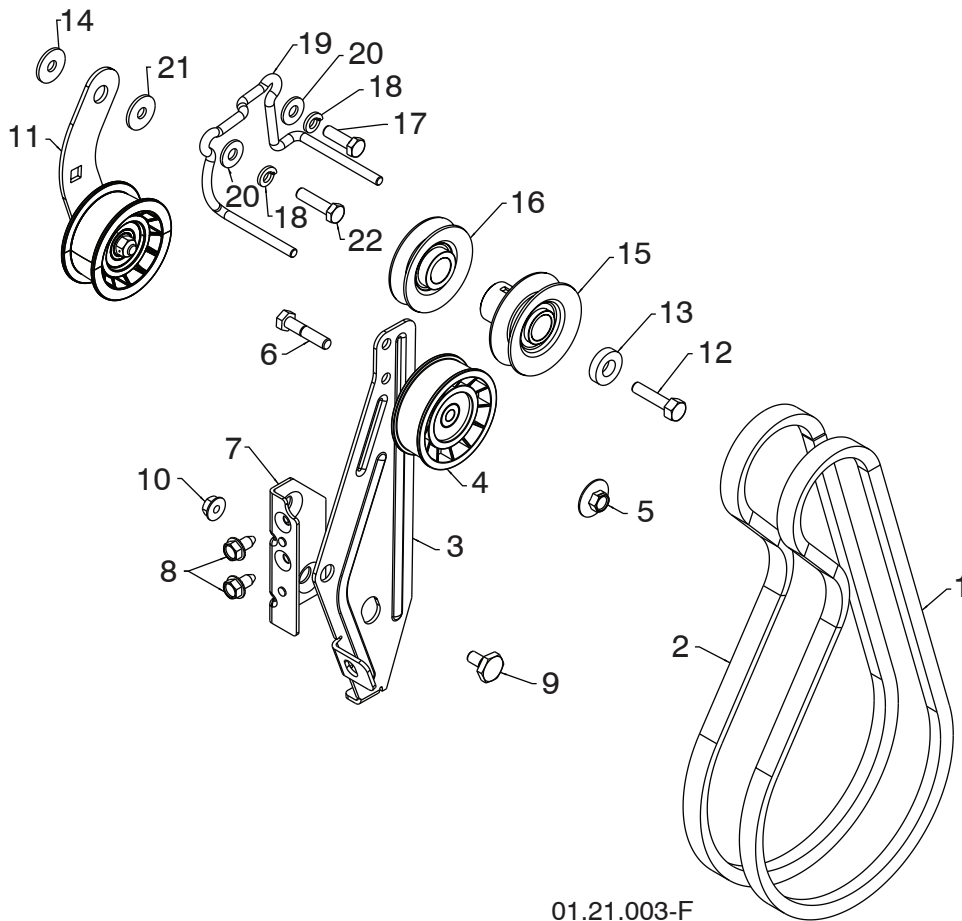

01.21.003-F

KEY NO.	PART NO.	DESCRIPTION	KEY NO.	PART NO.	DESCRIPTION
1	532 40 80-07	IMPELLER BELT	13	532 40 00-26	WASHER
2	532 41 97-44	TRACTION BELT	14	532 05 92-89	WASHER
3	584 23 24-02	IDLER ARM BRACKET	15	532 42 64-91	PULLEY ENG IMPELLER
4	532 18 05-23	IDLER PULLEY	16	532 42 64-90	PULLEY ENG TRACTION
5	532 42 65-89	NUT 5/16-18	17	874 61 05-16	SCREW 5/16-18 X 1.00
6	874 78 05-24	CAPSCREW 5/16-18 X 1.50	18	810 04 05-00	LOCKWASER 5/16
7	585 28 49-01	IDLER BRACKET	19	585 05 82-01	BELT GUIDE
8	817 00 05-10	SCREW 5/16-18 HEX	20	532 15 54-15	WASHER
9	532 42 42-97	SHOULDER BOLT 5/16-18 X .500	21	532 17 53-31	IDLER BUSHING
10	532 75 11-53	NUT 5/16-18 TOP LOCK	22	874 61 05-20	CAPSCREW HEX HEAD 5/16 X 1.25 GR5
11	585 23 84-01	TRACTION IDLER ARM ASM			
12	532 85 10-84	CAPSCREW 3/8-24 X 1.375			

NOTE: All component dimensions given in U.S. inches. 1 inch = 25.4 mm
IMPORTANT: Use only Original Equipment Manufacturer (O.E.M.) replacement parts. Failure to do so could be hazardous, damage your snow thrower and void your warranty.

REPAIR PARTS

CHASSIS / PULLEYS

SNOW THROWER - MODEL NO. **ST 261E** (96191003011), PRODUCT NO. 961 91 00-30

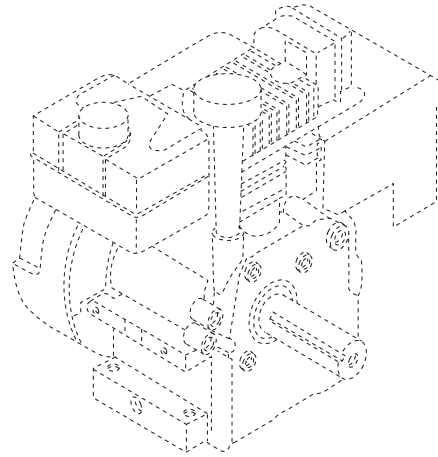
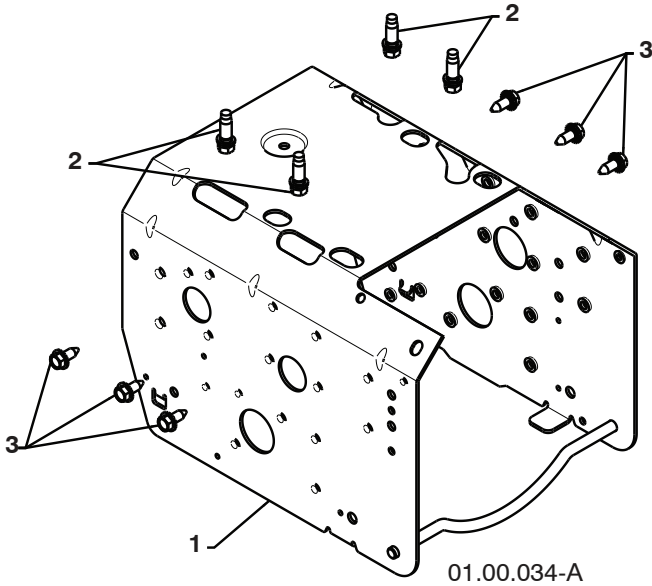

KEY NO.	PART NO.	DESCRIPTION
--	580 42 60-04	COMPLETE LCT ENGINE PW2HK18650178Y
1	532 43 59-52	FRAME
2	532 15 04-06	BOLT 3/8-16
3	532 42 88-67	SCREW 5/16-18 X .750

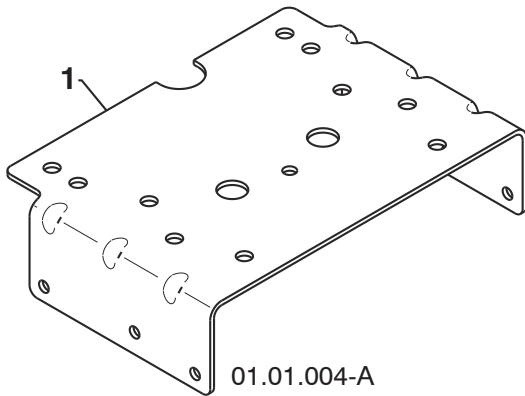

KEY NO.	PART NO.	DESCRIPTION
1	532 42 92-69	ENGINE MOUNTING PLATE

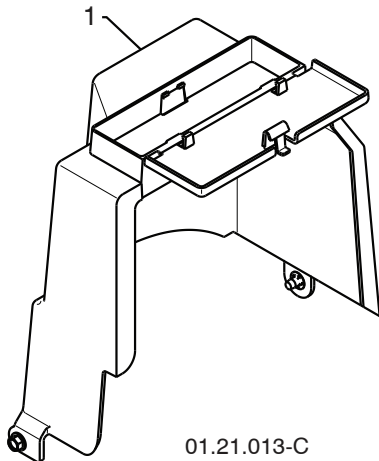

KEY NO.	PART NO.	DESCRIPTION
1	532 44 30-30	COVER ASSEMBLY

NOTE: All component dimensions given in U.S. inches. 1 inch = 25.4 mm
IMPORTANT: Use only Original Equipment Manufacturer (O.E.M.) replacement parts. Failure to do so could be hazardous, damage your snow thrower and void your warranty.

REPAIR PARTS

WHEELS

SNOW THROWER - MODEL NO. **ST 261E** (96191003011), PRODUCT NO. 961 91 00-30

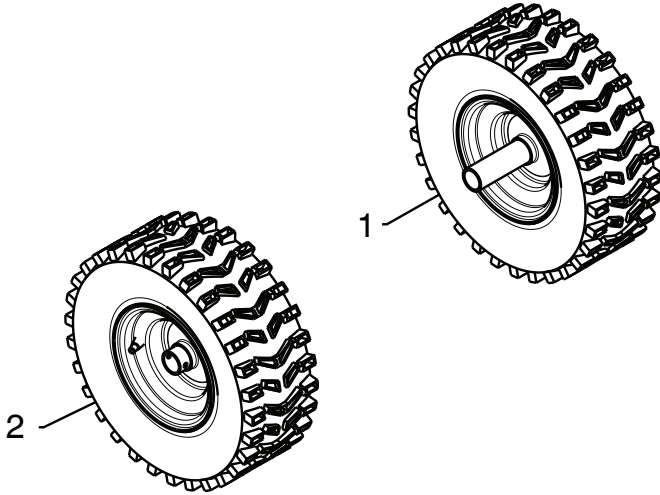

KEY NO.	PART NO.	DESCRIPTION
1	532 43 65-15	WHEEL 16 X 4.80 X LH
2	532 43 65-16	WHEEL 16 X 4.80 X RH

01.06.010-A

NOTE: All component dimensions given in U.S. inches. 1 inch = 25.4 mm
IMPORTANT: Use only Original Equipment Manufacturer (O.E.M.) replacement parts.
Failure to do so could be hazardous, damage your snow thrower and void your warranty.

REPAIR PARTS

BAG OF PARTS

SNOW THROWER - MODEL NO. **ST 261E** (96191003011), PRODUCT NO. 961 91 00-30

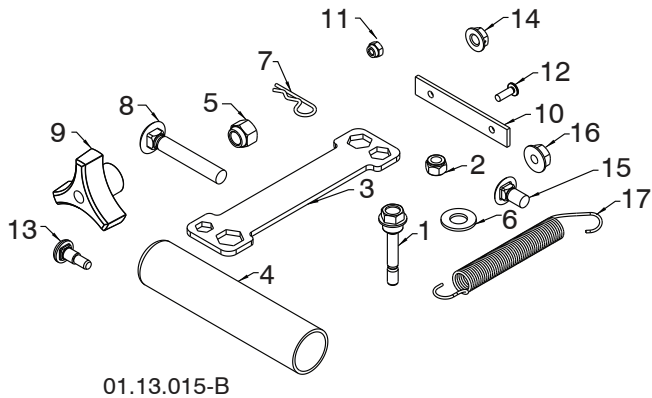

01.13.015-B

KEY NO.	PART NO.	DESCRIPTION
1	585 51 18-01	SCREW 1/4-20 X 1.81
2	873 80 04-00	NUT 1/4-20
3	532 42 91-12	WRENCH
4	532 18 04-47	SPRING SLEEVE
5	873 80 06-00	NUT HEX 3/8-16
6	819 13 13-16	WASHER 3/8 SAE
7	532 16 96-75	RETAINER HAIRPIN
8	872 12 06-18	BOLT 3/8-16 X 2.25
9	532 17 88-99	KNOB 3/8 TRI-LOBE
10	532 42 32-47	STRAP DEFLECTOR
11	532 18 22-28	NUT #8
12	532 18 22-27	SCREW #8 MACH
13	532 17 98-29	BOLT SHOULDER
14	532 19 17-30	NUT HEX 1/4-20 CTR
15	585 83 20-01	BOLT 5/16-18 X .625
16	532 75 11-53	NUT HEX 5/16-18
17	532 18 45-05	SPRING DEFLECT CHUTE

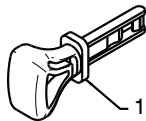

01.14.009-B

KEY NO.	PART NO.	DESCRIPTION
1	532 44 30-59	SAFETY IGNITION KEY KIT

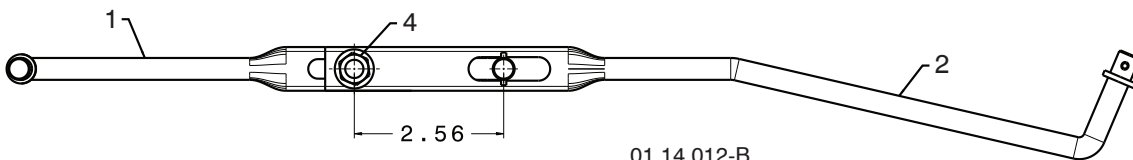
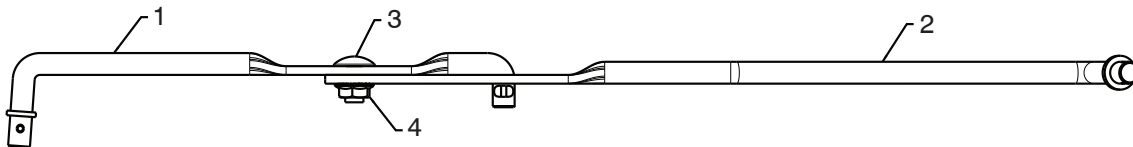

01.14.012-B

KEY NO.	PART NO.	DESCRIPTION
1	532 18 04-45	SHIFTER ROD TOP
2	532 18 77-16	SHIFTER ROD BOTTOM
3	872 27 05-05	CARRIAGE BOLT 5/16-18 X .75
4	532 15 53-77	NUT 5/16-18

NOTE: All component dimensions given in U.S. inches. 1 inch = 25.4 mm
IMPORTANT: Use only Original Equipment Manufacturer (O.E.M.) replacement parts. Failure to do so could be hazardous, damage your snow thrower and void your warranty.

REPAIR PARTS

DECALS

SNOW THROWER - MODEL NO. **ST 261E** (96191003011), PRODUCT NO. 961 91 00-30

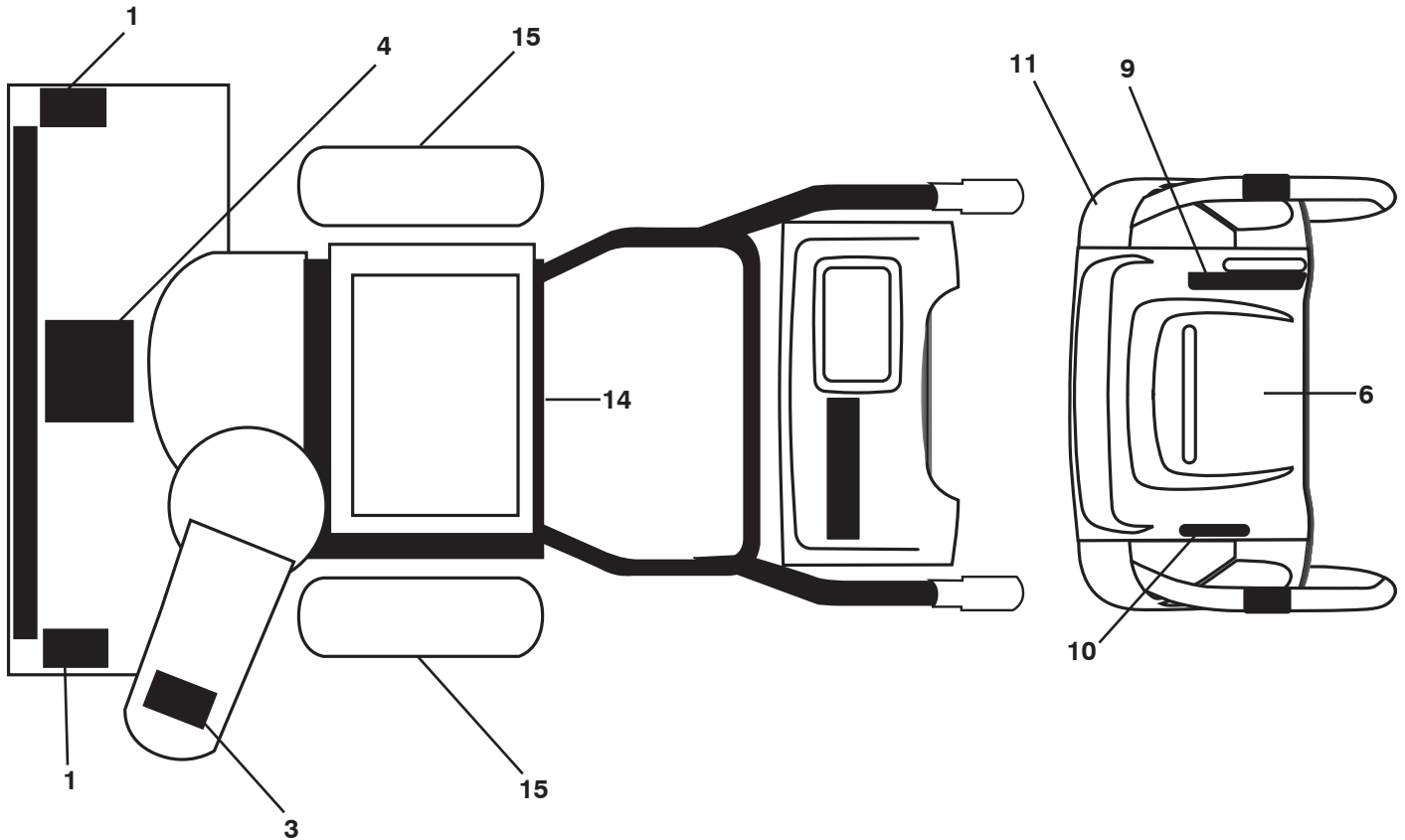

KEY PART NO. NO.

DESCRIPTION

1	532 19 96-83	DECAL, DANGER
3	532 19 96-82	DECAL, DANGER, DEFLECTOR
4	532 18 40-45	DECAL, DANGER
6	532 42 95-75	DECAL, INSTRUCTION
9	585 76 87-01	DECAL, RH
10	585 76 87-02	DECAL, LH
11	532 44 47-68	DECAL, HANDWARMER
14	532 18 04-33	DECAL, SOUND LEVEL
15	532 18 40-28	DECAL, BELT GUARD
--	115 71 93-20	OPERATOR'S MANUAL, EUROPEAN
--	115 71 93-10	OPERATOR'S MANUAL, SCANDINAVIAN
--	115 71 93-40	OPERATOR'S MANUAL, EAST BLOC
--	115 71 94-40	OPERATOR'S MANUAL, BALTIC

NOTE: All component dimensions given in U.S. inches. 1 inch = 25.4 mm

IMPORTANT: Use only Original Equipment Manufacturer (O.E.M.) replacement parts. Failure to do so could be hazardous, damage your snow thrower and void your warranty.

ENGINE, LCT

COMPLETE ENGINE-580426004

GEN II 136/179/208/254cc Snow Engines

9999 Options

DECALS ← 72

Carburetor
Repair Kit ← 70

*Keys Only (set of 2)

ILLUSTRATION FOR REFERENCE PURPOSES ONLY

KEY PART NO. NO.

DESCRIPTION

1	532 42 05-78	CYLINDER HEAD ASSEMBLY - 208CC (INCL. GASKET)
2	532 42 05-79	PUSH ROD & PLATE KIT (208CC) (INCL. VALVE COVER GSKT)
3	532 42 05-80	VALVE COVER (208CC) (INCL. GASKET)
4	532 43 65-67	CYLINDER - 208CC GEN LL SNOW
5	532 42 05-82	PISTON & ROD ASSEMBLY (208CC)
6	532 42 05-83	CONNECTING ROD ASSEMBLY (208CC)
7	532 42 05-84	CAMSHAFT - MCR (208CC)
8	532 42 92-35	FLYWHEEL - ELECTRIC START (6-CHARGING MAGNETS) (208CC)
9	532 42 05-86	COOLING FAN - FLYWHEEL (PLASTIC - 208CC)
10	532 44 66-42	CRANKSHAFT (#18 KEYED 208CC SNOW)

KEY PART NO. NO.

DESCRIPTION

13	532 43 65-63	MUFFLER ASSEMBLY-GEN LL SNOW
14	532 43 65-64	FUEL TANK (208CC-SNOW) (2.7L BLACK W/PLASTIC CAP - GEN II)
15	532 42 92-34	FUEL TANK ON/OFF VALVE - GEN II SNOW
16	532 42 49-42	FUEL TANK CAP - BLACK CLICK STYLE (VENTED)
17	532 43 65-65	CARBURETOR (L10-1D) W-IDLE CONTROL (GEN II SNOW 208CC-W/GSKTS & SPACER)
18	532 44 39-34	IGNITION COIL (CDI) (208/254CC) (STANDARD)
19	532 42 49-55	CDI MODULE - BLACK BOX (USED ON 2-PC IGNITION SYSTEM)
20	532 42 49-39	SPARK PLUG
21	532 42 49-57	ON/OFF SWITCH - ROCKER
22	532 42 49-75	SHIELD - FLYWHEEL - ELECTRIC START - SNOW

NOTE: All component dimensions given in U.S. inches. 1 inch = 25.4 mm
IMPORTANT: Use only Original Equipment Manufacturer (O.E.M.) replacement parts. Failure to do so could be hazardous, damage your snow thrower and void your warranty.

ENGINE, LCT

KEY NO.	PART NO.	DESCRIPTION
23	532 43 21-44	FUEL HOSE KIT (1/4" ID X 318MM - SS SNOW)
24	532 42 92-59	SPEED CONTROL BRACKET (FIXED)
25	532 42 96-46	GOVERNOR GEAR ASSEMBLY (136/208CC)
26	581 76 87-01	GOVERNOR ARM & LINK KIT (208CC SNOW - 3600 FIXED RPM)
27	532 42 06-02	GOVERNOR ARM PADDLE
28	532 43 69-67	RECOIL STARTER (ROUND STYLE-BLACK) 136/208CC GEN II SNOW
29	532 43 69-68	STARTER CUP (USE WITH ROUND STYLE STARTER) (208CC SNOW)
30	580 96 05-01	BLOWER HOUSING - BLACK ELECTRIC START W/WELD NUT (208CC) (SN >1165H0313865)
31	585 77 27-01	CRANKCASE COVER ASSY-HOFT (THREADED) (INCL. GASKET) (SN <1265H0519257)
32	532 42 95-99	OIL SEAL KIT (2 PCS FOR 3/4-INCH CRANKSHAFT)
34	532 43 69-66	SPARK PLUG BOOT - WITH METAL SHIELD (SNOW)
35	532 43 66-71	230V ELECTRIC STARTER (208CC GEN LL)
36	532 42 96-01	ENGINE GASKET KIT (208CC)
37	532 42 09-61	SMALL BLACK OIL DIPSTICK (PLASTIC)
38	532 42 96-91	ROCKER ARM KIT (208CC) (INCL. GASKET)
39	532 42 92-24	CHOKE CONTROL KNOB (GEN II RED)
40	532 42 95-98	NON-REMOVABLE PLASTIC PLUG (136/208/254CC)
42	N/A	N/A
43	580 35 34-01	BREATHER TUBE (136/208/254CC)
47	581 00 72-01	HIGH OIL-FILL TUBE/DIPSTICK (THREADED) (SN <1265H0519257)
48	532 42 92-62	WIRE HARNESS (208CC SNOW)
49	532 43 54-95	OIL DRAIN PLUG W/WASHER (136/208/254CC)
50	532 43 65-61	HEATER BOX KIT (GEN LL 208CC SNOW)
51	532 43 71-19	SHIELD - CYLINDER (208CC SNOW)

COMPLETE ENGINE-580426004

KEY NO.	PART NO.	DESCRIPTION
52	532 42 49-49	PRIMER BULB WITH HOSE-SNOW
53	532 42 49-54	KEY SWITCH - SAFETY (PUSH/PULL) SNOW (INCL. KEYS)
54	532 44 30-59	KEY SET - RED (2) (SNOW)
55	532 43 26-86	OIL DRAIN TUBE-SNOW (136/208CC)
56	532 42 92-60	CARBURETOR VAPOR SHIELD - 208CC SNOW
57	532 43 66-72	CE COMPLIANT MUFFLER SHIELD (208CC)
58	532 42 49-60	SHIELD - GOVERNOR LINKAGE - 208CC SNOW
59	532 43 65-62	FUEL TANK SKIRT (208CC SNOW)
60	532 42 49-59	CHARGING COIL (60-WATT AC) (208/254CC)
61	532 43 27-52	FUEL CONTROL KNOB (GEN II SNOW - RED)
62	532 42 49-68	STARTER GRIP-SNOW
65	581 37 28-01	TAPPET KIT (208/254CC) (SET OF 2)
69	532 42 49-51	CARBURETOR STUDS & COUPLING KIT-SNOW
70	580 35 36-01	CARBURETOR REPAIR KIT (136/208/254CC)
72	532 43 56-47	STORMFORCE LABEL KIT-208CC SNOW
74	581 76 88-01	MUFFLER HEAT SHIELD COVER (136/208/254)
77	532 43 26-88	RECOIL BOLT KIT (INCL. (3) MTG BOLTS)
78	581 45 93-01	BREATHER TUBE BRACKET
79	585 77 37-01	CARBURETOR COVER (136/208/254CC SNOW)
80	N/A	N/A
81	585 29 72-01	WOODRUFF FLYWHEEL KEYS (5-PACK) (5X6X18MM)
82	585 02 05-03	CARBURETOR SPACER (208/254CC)
85	586 32 56-01	FUEL TANK STRAINER
86	586 32 73-01	CYLINDER HEAD BOLT KIT (4) (136-179-208-254CC)
87	586 32 69-01	CC COVER BOLT KIT (6) (179-208-254CC)
88	586 32 68-01	MUFFLER MTG STUD KIT (2)
89	587 12 48-01	SPEED CONTROL KNOB, GEN II, SNOW
91	587 52 57-01	CRANKCASE GASKET KIT
9999	586 32 62-01	HIGH ALTITUDE JET (>5,000 FEET) (208CC L10-1 CARBURETOR)

NOTE: All component dimensions given in U.S. inches. 1 inch = 25.4 mm
IMPORTANT: Use only Original Equipment Manufacturer (O.E.M.) replacement parts.
 Failure to do so could be hazardous, damage your snow thrower and void your warranty.

