

ILLUSTRATED PARTS LIST

MFG. ID NO. 96051012500

CUSTOMER CATALOG NO. TC 142

PRODUCT NO. 960 51 01-25

47

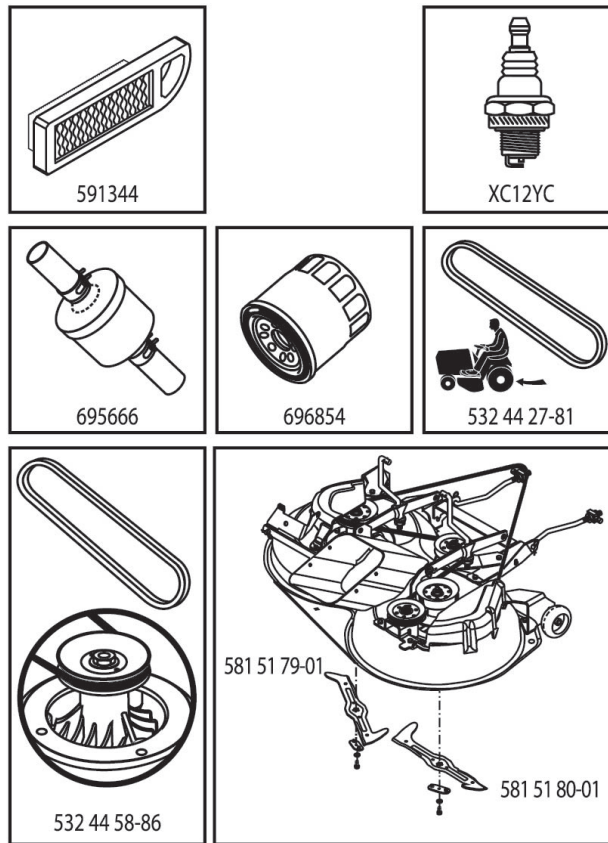

587456501

TRACTOR - MODEL NO. TC 142 (96051012500), PRODUCT NO. 960 51 01-25
DECALS 27

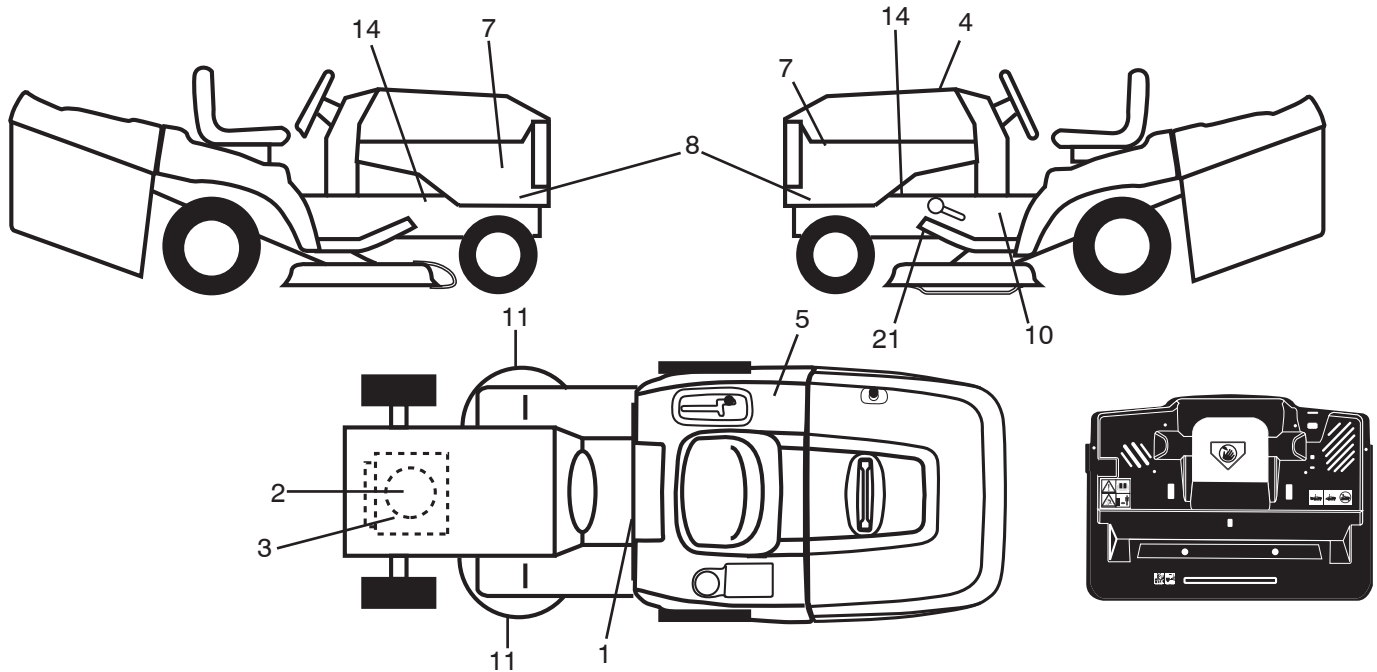

KEY NO.	PART NO.	DESCRIPTION
1	581 57 83-01	Decal, Warn Combined
2	581 57 97-01	Decal, Warning Eng. Sym.
3	587 38 53-01	Decal, Engine
4	587 45 65-01	Decal, Replacement
5	581 72 41-01	Decal, Certification
7	581 62 73-01	Decal, Hood
8	587 55 18-01	Decal, Side Panel
10	581 57 98-01	Decal, Warning
11	581 57 91-01	Decal, Mower Cut Finger Symbol

KEY NO.	PART NO.	DESCRIPTION
14	581 57 96-01	Decal, Chassis Hot Muffler
21	532 44 11-89	Decal, Belt Schematic
--	532 44 46-19	Decal, Bypass
--	532 44 14-09	Pad Footrest LH
--	532 44 14-10	Pad Footrest RH
--	587 56 73-40	Manual Operator's (Euro)
--	587 56 74-50	Manual Operator's (Scan)
--	587 56 75-20	Manual Operator's (E-Bloc)
--	587 56 75-30	Manual Operator's (Baltic)

WHEELS AND TIRES

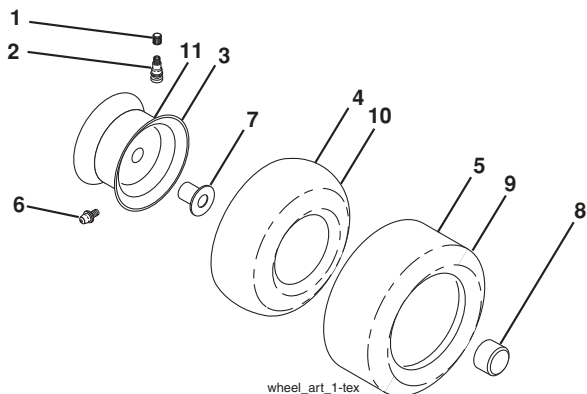

wheel_art_1-tex

KEY NO.	PART NO.	DESCRIPTION
1	532 05 91-92	Cap Valve Tire
2	532 06 51-39	Stem Valve
3	532 13 83-36	Rim Front
4	532 05 99-04	Tube Front (Service Item Only)
5	532 10 62-22	Tire Front 15 x 6-6
6	532 12 49-57	Fitting Grease (Front Wheel Only)
7	532 12 49-59	Bearing Flange (Front Wheel Only)
8	532 17 50-39	Cap Axle Blk 1 50 x 1 00
9	532 42 05-31	Tire Rear 18 x 9.5-8
10	532 12 49-26	Tube Rear (Service Item Only)
11	532 13 83-37	Rim Asm 8" Rear
--	532 14 43-34	Sealant, Tire (10 oz. Tube)

NOTE: All component dimensions given in U.S. inches
 1 inch = 25.4 mm

TRACTOR - MODEL NO. TC 142 (96051012500), PRODUCT NO. 960 51 01-25

SCHEMATIC **38**

SCH26

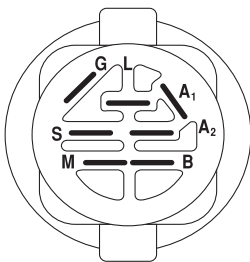
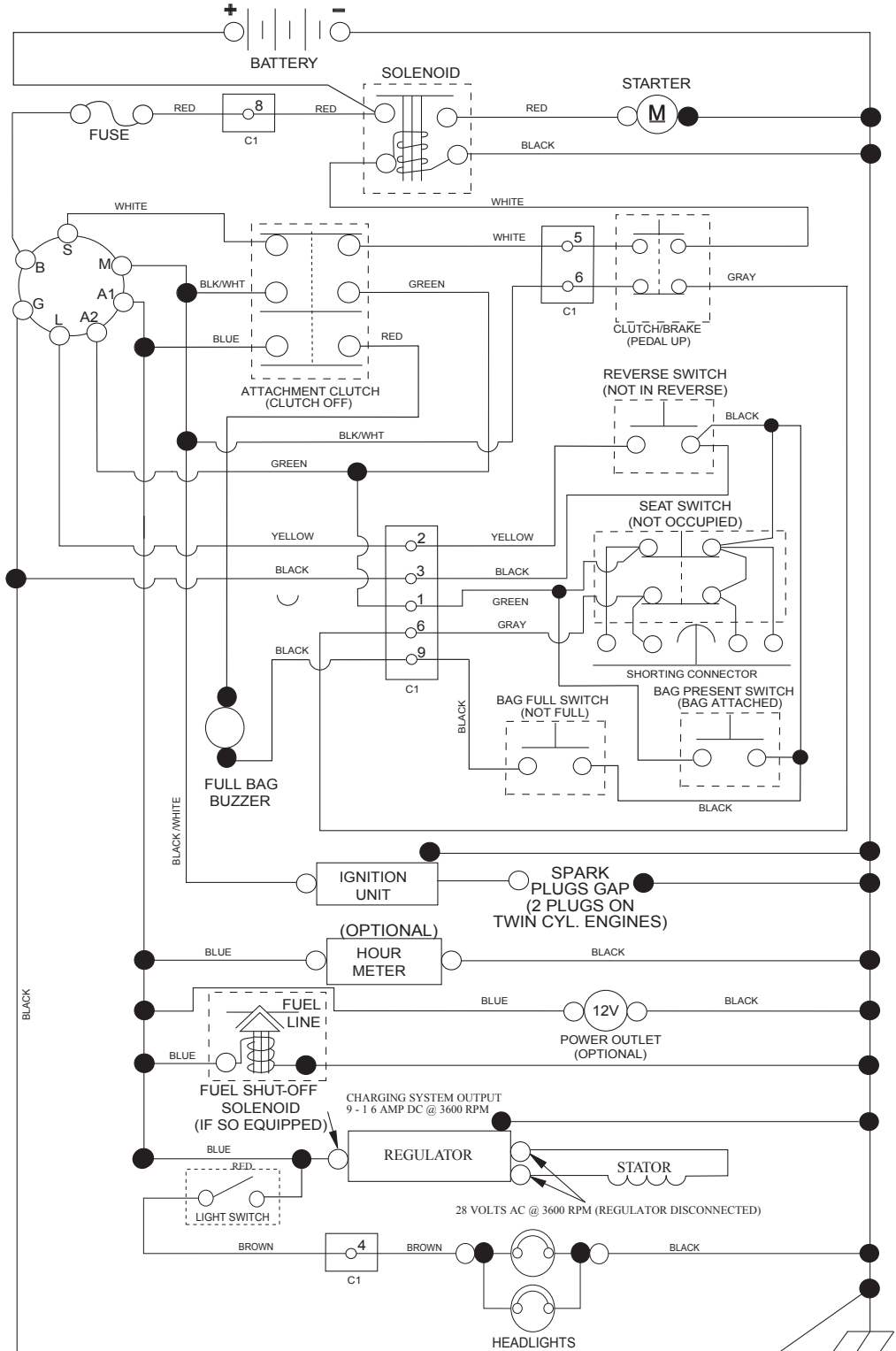

IGNITION SWITCH

POSITION	CIRCUIT	"MAKE"
OFF	M+G+A1	
RUN/OVERRIDE	B+A1	
RUN	B+A1	L+A2
START	B + S + A1	

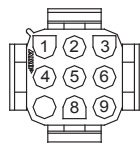

CHASSIS HARNESS CONNECTOR (C1) (MATING SIDE)

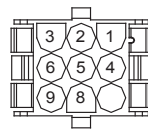

DASH HARNESS CONNECTOR (C1) (MATING SIDE)

WIRING INSULATED CLIPS
NOTE: IF WIRING INSULATED CLIPS WERE REMOVED FOR SERVICING OF UNIT, THEY SHOULD BE RE-INSTALLED TO PROPERLY SECURE YOUR WIRING.

● NON-REMOVABLE CONNECTIONS

○ REMOVABLE CONNECTIONS

TRACTOR - MODEL NO. TC 142 (96051012500), PRODUCT NO. 960 51 01-25
ELECTRICAL 32

TC03S

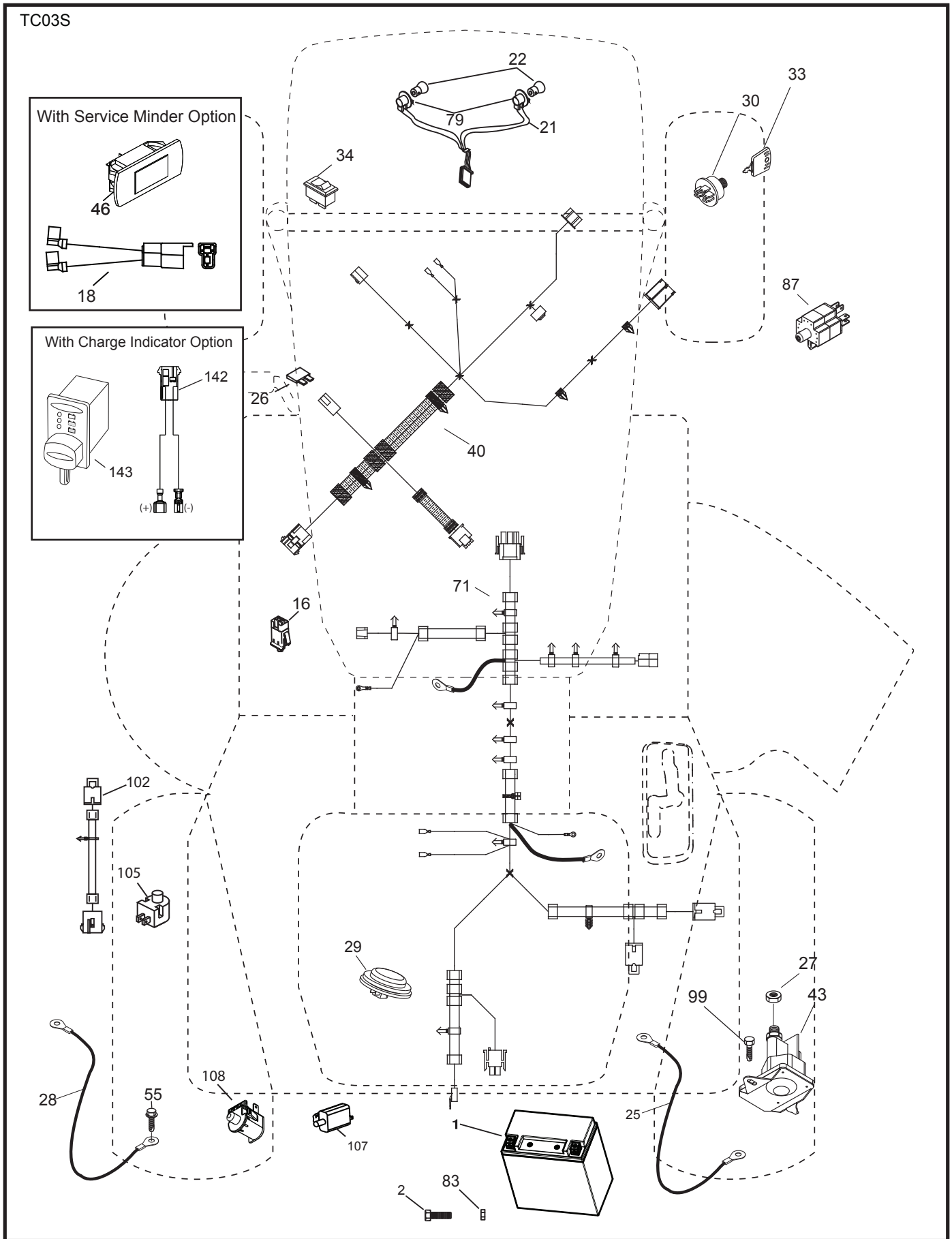

**TRACTOR - MODEL NO. TC 142 (96051012500), PRODUCT NO. 960 51 01-25
ELECTRICAL 32**

KEY NO.	PART NO.	DESCRIPTION
1	532 43 71-57	Battery
2	532 44 09-23	Screw Hex Hd Cap M6 x 1.12MM
16	532 17 61-38	Switch Interlock Push-In
21	532 40 02-52	Harness Light w/4152J
22	532 00 41-52	Bulb Light
25	532 44 13-83	Cable Starter
26	532 17 51-58	Fuse
27	873 51 04-00	Nut Keps Hex 1/4-20 unc
28	532 44 18-32	Cable, Ground
29	532 40 15-45	Switch, Seat
30	532 19 33-50	Switch, Ign
33	532 41 19-35	Key/Chain
34	532 11 07-12	Switch Light/Reset
40	585 84 99-01	Harness Ign. Dash
43	532 19 25-07	Solenoid
55	817 06 05-12	Screw Thdrol 5/16-18 x 3/4 TYTT
71	587 26 87-01	Harness Ignition Chassis
79	532 17 52-42	Socket Asm. Bulb
83	532 43 67-74	Nut Square M6 x 1.8.5 x 11MM
87	532 42 10-60	Switch
99	817 72 04-08	Screw 1/4-20 x 1/2
102	532 44 12-62	Harness Jumper
105	532 40 75-68	Switch Reverse
107	532 18 03-79	Switch Full Bagger
108	532 42 10-62	Switch Snapmount
142	583 85 78-01	Harness Charge Port
143	532 44 80-59	Charge Port

NOTE: All component dimensions given in U.S. inches
1 inch = 25.4 mm

TRACTOR - MODEL NO. TC 142 (96051012500), PRODUCT NO. 960 51 01-25
CHASSIS AND ENCLOSURES 39

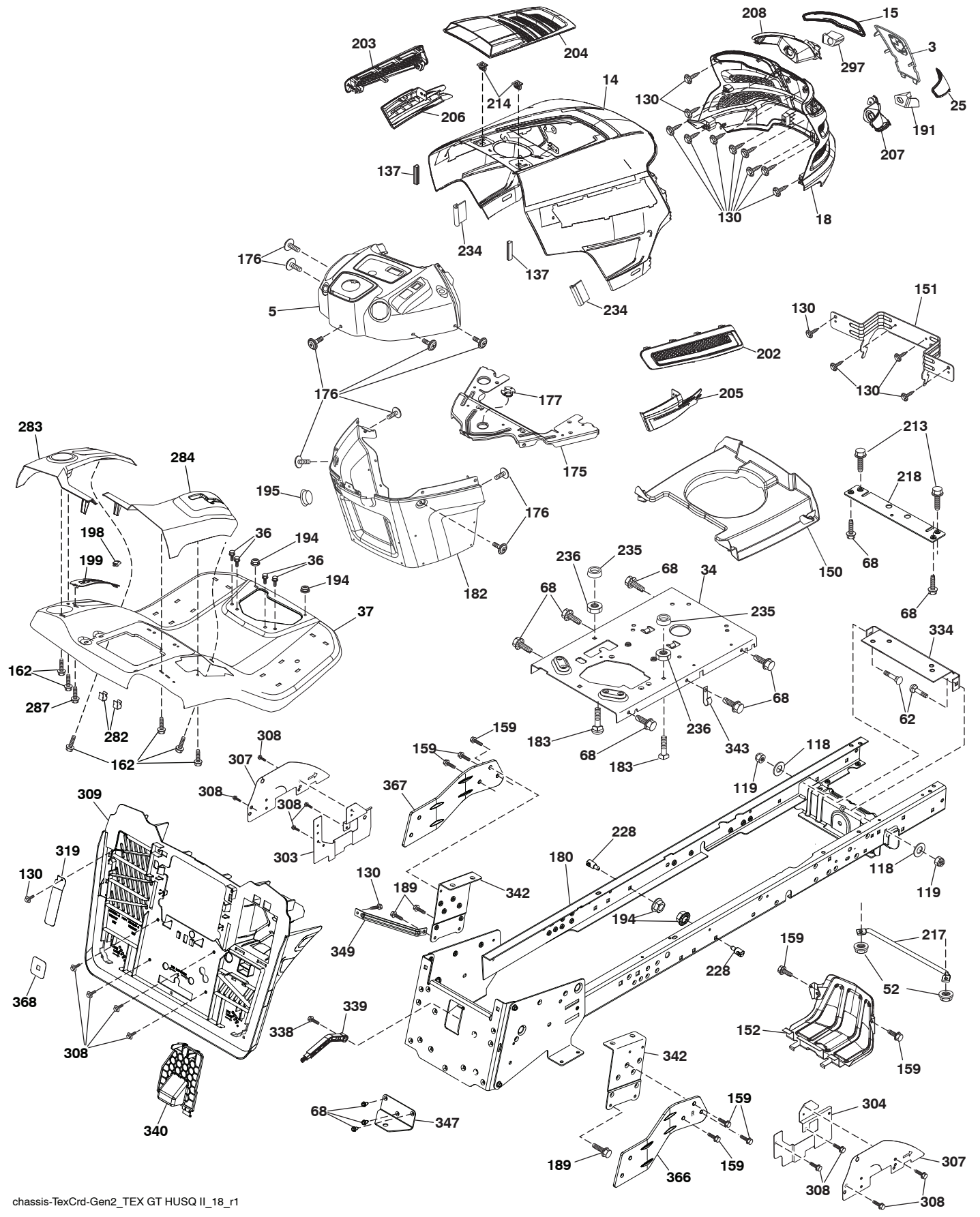

**TRACTOR - MODEL NO. TC 142 (96051012500), PRODUCT NO. 960 51 01-25
CHASSIS AND ENCLOSURES 39**

KEY PART NO. NO.	DESCRIPTION	KEY PART NO. NO.	DESCRIPTION	
3	532 44 44-81	Applique	208 532 43 97-35	Bezel LH
5	581 46 69-05	Dash	213 874 76 05-12	Bolt 5/16-18 x 3/4
14	532 44 11-77	Hood	214 532 19 91-45	Clip Retainer Tinner
15	532 43 97-33	Lens LH	217 532 40 91-67	Rod Pivot
18	532 44 06-53	Grille	218 532 19 63-95	X-Piece Hood Stop
25	532 44 33-85	Lens RH	228 532 19 51-61	Stud Fastner
34	580 91 09-01	Plate Engine	234 532 40 47-42	Bumper Hood
36	817 06 05-12	Screw 5/16-18 x 3/4	235 532 40 61-29	Spacer Fender
37	532 44 13-69	Fender	236 873 93 05-00	Nut Lock 5/16-18 unc
52	873 68 05-00	Nut Lock 5/16-18	282 532 41 41-10	Clip Retainer
62	872 11 06-08	Bolt RdHd Sqnk 3/8-16 x 1 gr. 5	283 532 44 72-12	Console Deck Lift LH
68	817 49 05-08	Screw Thdrol 5/16-18 x 1/2	284 532 44 72-20	Console Shft RH
118	819 13 13-16	Washer 13/32 x 13/16 x 16 Ga.	287 817 60 04-06	Screw 1/4-20 x 3/8
119	873 68 06-00	Nut Crownlock 3/8-16 unc	297 532 43 74-56	Insert Reflective LH
130	532 41 63-58	Screw #10 x 0.750	303 587 49 31-02	Shield Chassis French LH
137	532 40 75-90	Bumper Dash	304 587 49 27-02	Shield Chassis French RH
150	532 43 97-74	Air Duct	307 587 49 45-01	Shield Upper French
151	532 43 66-70	Bracket Pivot	308 532 17 18-77	Bolt 5/16-18 unc x 3/4 w/Sems
152	532 43 98-70	Shield Browning	309 581 32 89-11	Backplate
159	817 00 06-12	Screw Hexwsh Thrd 3/8-16 x 3/4	319 581 31 39-06	Lever Bag
162	532 14 24-32	Screw	334 532 44 25-37	Bracket Engine
175	532 19 63-04	Crossmember	338 532 43 66-40	Bolt Shoulder
176	532 40 07-76	Screw 10-24 x 5/8	339 532 43 66-41	Lever Bagger Full
177	532 19 52-27	Bushing Steering	340 581 32 90-01	Door Battery
180	583 90 27-01	Chassis	342 532 43 59-38	Supprt Fender
182	586 73 86-02	Dash Lower	343 532 44 07-49	Clip
183	874 52 05-20	Bolt 5/16-18 x 1-1/4	347 532 44 58-32	Hitch Tow
189	817 00 05-12	Screw 5/16-18 x 3/4	349 532 43 66-06	Bracket Support
191	532 43 74-55	Insert Reflective RH	366 581 31 46-02	Bracket RH Front Bagger
194	873 90 05-00	Nut Lock Hex Flange 5/16-18	367 581 31 45-02	Bracket LH Front Bagger
195	532 40 41-37	Plug Hole Dash Lower	368 581 42 48-01	Full Lever Bagger
198	532 44 15-52	Indicator Deck Lift	-- 532 43 99-76	Plug Dash
199	532 41 87-39	Plate Deck Lift		
202	532 43 97-28	Vent Side Hood RH		
203	532 43 97-27	Vent Side Hood LH		
204	587 48 58-01	Vent Top Hood		
205	532 43 97-30	Skirt Hood Side RH		
206	532 43 97-29	Skirt Hood Side LH		
207	532 43 97-34	Bezel RH		

NOTE: All component dimensions given in U.S. inches
1 inch = 25.4 mm

**TRACTOR - MODEL NO. TC 142 (96051012500), PRODUCT NO. 960 51 01-25
DRIVE **40****

KEY NO.	PART NO.	DESCRIPTION	KEY NO.	PART NO.	DESCRIPTION
1	---	Transaxle, Tufftorq K46DF (446488) (Order parts from trans-axle manufacturer.)	186	532 19 43-21	Spacer Retainer
2	532 12 35-83	Key Square	188	532 19 43-23	Link Clutch
6	532 12 40-28	Bushing Snap	189	532 43 36-11	Bellcrank Ground Drive
17	532 43 62-27	Spring Brake K46	195	580 45 69-01	Bracket Rod Brake CRD Tex
27	817 49 05-28	Screw Hexwsh Thd 5/16-18 x 1-3/4	203	819 11 11-16	Washer 11/32 x 1-1/16 x 16 Ga.
29	532 44 27-95	Rod, Brake	205	532 12 17-48	Washer 25/32 x 1-5/8 x 16 Ga.
30	819 13 16-16	Washer	210	532 40 09-80	Rocker Asm. Pedal Control
33	812 00 00-01	Ring E	211	532 12 01-83	Bearing Nylon
35	583 86 45-01	Rod, Brake, Park	214	532 42 12-63	Pedal Forward
37	532 18 89-67	Washer Harden 793 x 1063 x 060	215	532 41 94-82	Pedal Reverse
38	532 16 96-13	Nyliner Bushing	221	532 40 31-87	Retainer Spring Clip Handle
42	532 12 48-74	Cover, Foot Pedal	222	879 21 20-10	Washer 21/32 x 1-1/4 10 Ga.
49	872 11 06-14	Bolt Rdhd 3/8-16 unc x 3/4 Gr. 5	226	532 40 15-64	Bracket Strap Torque
50	532 19 43-27	Idler Flat	227	817 49 05-12	Screw
51	873 90 06-00	Lock Nut 3/8-16	279	532 44 42-83	Link Shift
52	532 19 43-26	Idler V-Groove	280	819 11 10-12	Washer 11/32 x 5/8 x 12 Ga.
56	532 44 27-81	V-Belt, Drive	309	532 16 55-81	Plate Fstnr Cross Shf
61	532 44 51-51	Pulley Transaxle K46	311	532 16 98-45	Washer Nylon
64	532 19 78-65	Shaft Asm. Pedal Brake Control	312	532 16 56-14	Hub Tapered
73	874 49 05-44	Bolt Flanged	313	874 78 04-16	Bolt Hex Fin 1/4-20 unc x 1 Gd5
90	532 44 36-05	Keeper Belt Clutching	314	532 44 47-13	Keeper Belt
99	532 44 39-47	Rod Spring Bypass	315	817 58 05-20	Screw Thdrol 5/16-18 x 4.25
103	873 35 05-00	Nut Hex Jam 5/16-18	335	532 19 95-34	Pulley V-Idler
116	873 90 05-00	Nut Lock Hex Flange 5/16-18	339	532 43 68-67	Strap Torque K46 CRD Tex
125	817 00 05-12	Screw 5/16-18 x 3/4	342	532 18 26-82	Keeper Belt 2.5" STL V-Idlr CRD
140	810 04 04-00	Washer Lock Hvy Helical 1/4	351	532 43 69-98	Bracket 97 CRD Deck Sway
143	817 49 05-08	Screw 5/16-18 x 1/2	352	532 43 56-45	Bracket Idler CRD Tex
159	876 02 04-12	Pin Cotter 1/8 x 3/4	355	532 43 56-69	Bracket
160	532 16 94-84	Retainer Clip	359	817 49 06-10	Screw Thdrol 3/8-16 x 5/8
161	532 10 57-09	Spring, Return, Clutch	360	532 44 47-14	Nut 5/16-24 UNF
163	532 44 27-93	Rod Control	362	532 43 68-12	Idler Flat
166	532 42 91-64	Nut Push	363	532 44 27-80	Spacer 343 x 63 x .62
167	532 40 52-57	Latch Brake Parking	364	532 44 30-32	Bracket Idler CRD Tex
175	532 42 93-59	Shaft Asm Crossshift Rear Crd	372	587 06 27-01	Keeper Belt Transaxle
183	532 13 70-57	Spacer Axle			
184	587 65 37-01	Handle Parking Brake			
185	872 11 06-22	Bolt 3/8-16 unc x 2-3/4 G5			

NOTE: All component dimensions given in U.S. inches
1 inch = 25.4 mm

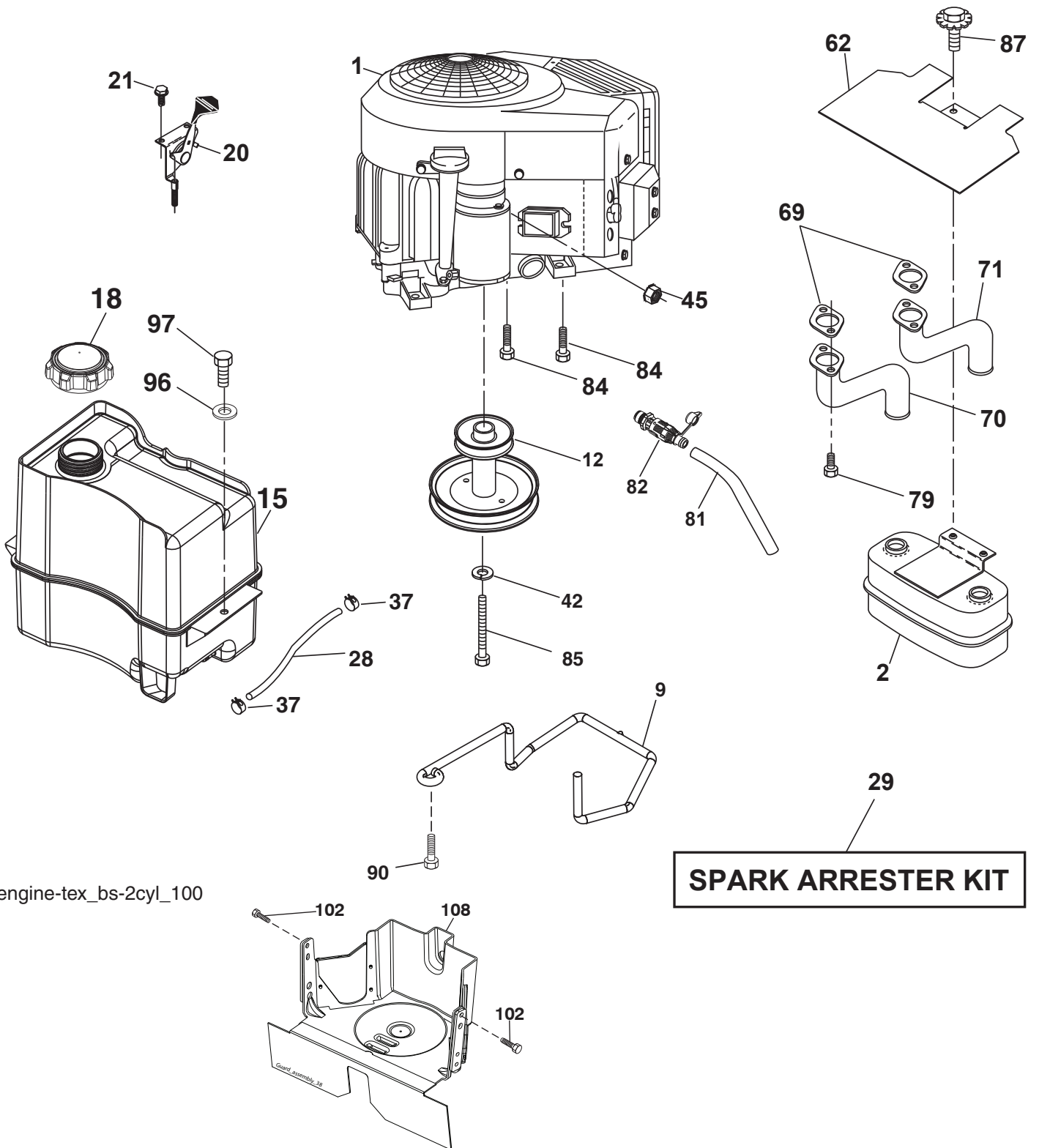

engine-tex_bs-2cyl_100

**TRACTOR - MODEL NO. TC 142 (96051012500), PRODUCT NO. 960 51 01-25
ENGINE 24**

KEY NO.	PART NO.	DESCRIPTION
1	-----	Engine B&S Model No. 40R777-0016-B1 (587393801) (Order parts from engine manufacturer.)
2	532 44 59-62	Muffler
9	584 90 80-01	Keeper Belt Engine
12	532 40 54-71	Pulley Engine
15	581 29 01-01	Tank Fuel
18	532 43 02-20	Fuel Cap
20	532 42 35-02	Control Throttle
21	532 41 63-58	Screw # 10 x 0.750
28	532 13 70-40	Fuel Line
29	532 13 71-80	Spark Arrester Kit
37	532 12 34-87	Clamp Hose
42	810 04 07-00	Washer Lock 7/16
45	873 51 04-00	Nut Keps Hex 1/4-20 unc
62	532 43 40-17	Shield Heat Muffler
69	532 16 53-91	Gasket
70	581 88 11-01	Tube Exhaust LH
71	581 88 10-01	Tube Exhaust RH
79	532 18 39-06	Screw
81	532 14 84-56	Tube Drain Oil Easy
82	532 42 82-87	Valve Oil Drain
84	817 06 06-20	Screw
85	532 17 39-37	Bolt Hex 7/16-20 x 4 x Gr. 5-1.5 Thr
87	532 17 18-77	Bolt 5/16-18 unc x 3/4 w/Sems
90	817 00 06-16	Screw 3/8-16 x 1
96	819 09 14-16	Washer 9/32 x 7/8 x 16 Ga.
97	817 67 04-12	Screw 1/4-20 x 3/4
102	817 06 05-16	Screw 5/16-18 x 1
108	532 42 30-41	Cover Pulley Engine

NOTE: All component dimensions given in U.S. inches
1 inch = 25.4 mm

TRACTOR - MODEL NO. TC 142 (96051012500), PRODUCT NO. 960 51 01-25
STEERING ASSEMBLY 41

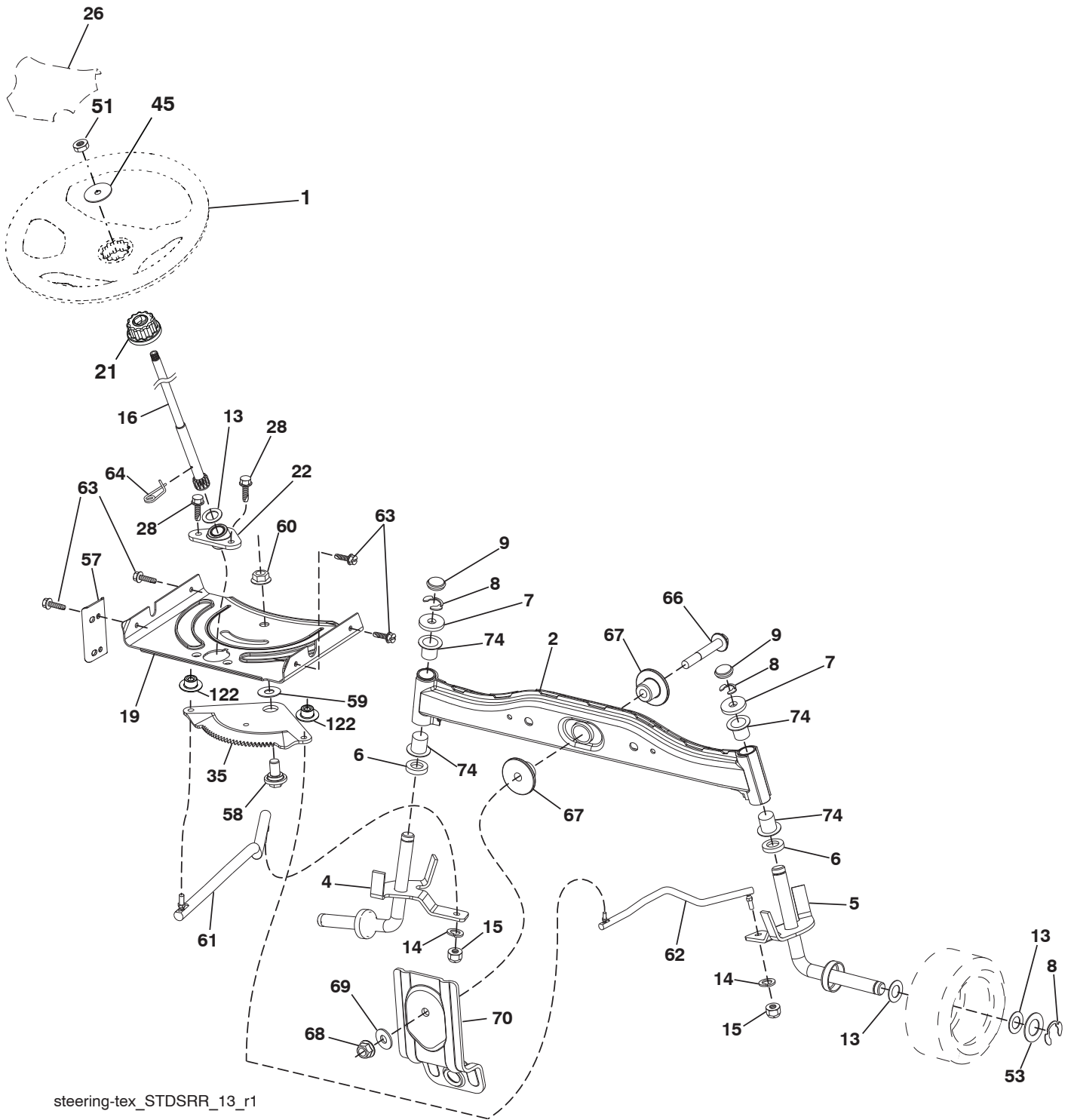

steering-tex_STDSRR_13_r1

**TRACTOR - MODEL NO. TC 142 (96051012500), PRODUCT NO. 960 51 01-25
STEERING ASSEMBLY **41****

KEY NO.	PART NO.	DESCRIPTION
1	532 43 99-97	Wheel, Steering
2	532 41 81-68	Axle Asm.
4	532 40 30-87	Spindle, LH
5	532 40 30-88	Spindle, RH
6	532 12 49-31	Washer Thrust 0.75 x 1.23
7	532 12 17-48	Washer 25/32 x 1-5/8 x 16 Ga.
8	812 00 00-29	Ring, Klip #T5304-75
9	532 12 12-32	Cap, Spindle
13	532 12 17-49	Washer 25/32 x 1-1/4 x 16 Ga.
14	810 04 06-00	Washer, Lock 3/8
15	873 54 06-00	Nut, Crown Lock 3/8-24 unf
16	532 19 47-46	Shaft Steering
19	532 19 47-29	Plate Steering
21	532 18 67-37	Adapter, Wheel Steering
22	532 42 05-37	Steering Support
26	532 43 97-43	Insert, Wheel Steering
28	817 00 06-12	Screw 3/8-16 x 3/4
35	532 19 47-32	Gear, Sector Plate
45	819 18 38-12	Washer 9/16 ID x 2-3/8 OD
51	873 94 08-00	Nut Hex Jam Toplock 1/2-20 UNF
53	532 18 89-67	Washer Hardened .793 x 1.637 x .060
57	532 40 74-65	Bracket Upstop
58	532 19 47-47	Bolt Shoulder Sector Pivot CFM
59	532 19 47-48	Washer Thrust Sector Steering
60	873 97 10-00	Nut Flange Lock 5/8-11
61	532 19 47-40	Draglink, LH
62	532 19 47-41	Draglink, RH
63	817 00 05-12	Screw 5/16-18 x 3/4
64	532 19 98-49	Retainer Clip Spring Steering
66	871 02 07-48	Bolt Hex Fghd 7/16-14 x 3 Serr
67	532 19 47-37	Bushing PM Front Axle
68	873 90 07-00	Nut Lock Flange 7/16-14 Gr. 5
69	532 19 91-62	Washer 1.5 x .505 x .118
70	585 33 88-01	Bracket Deck Susp. Front
74	532 12 49-37	Bearing
122	532 44 49-62	Cap Gear

NOTE: All component dimensions given in U.S. inches
1 inch = 25.4 mm

TRACTOR - MODEL NO. TC 142 (96051012500), PRODUCT NO. 960 51 01-25
MOWER DECK 44

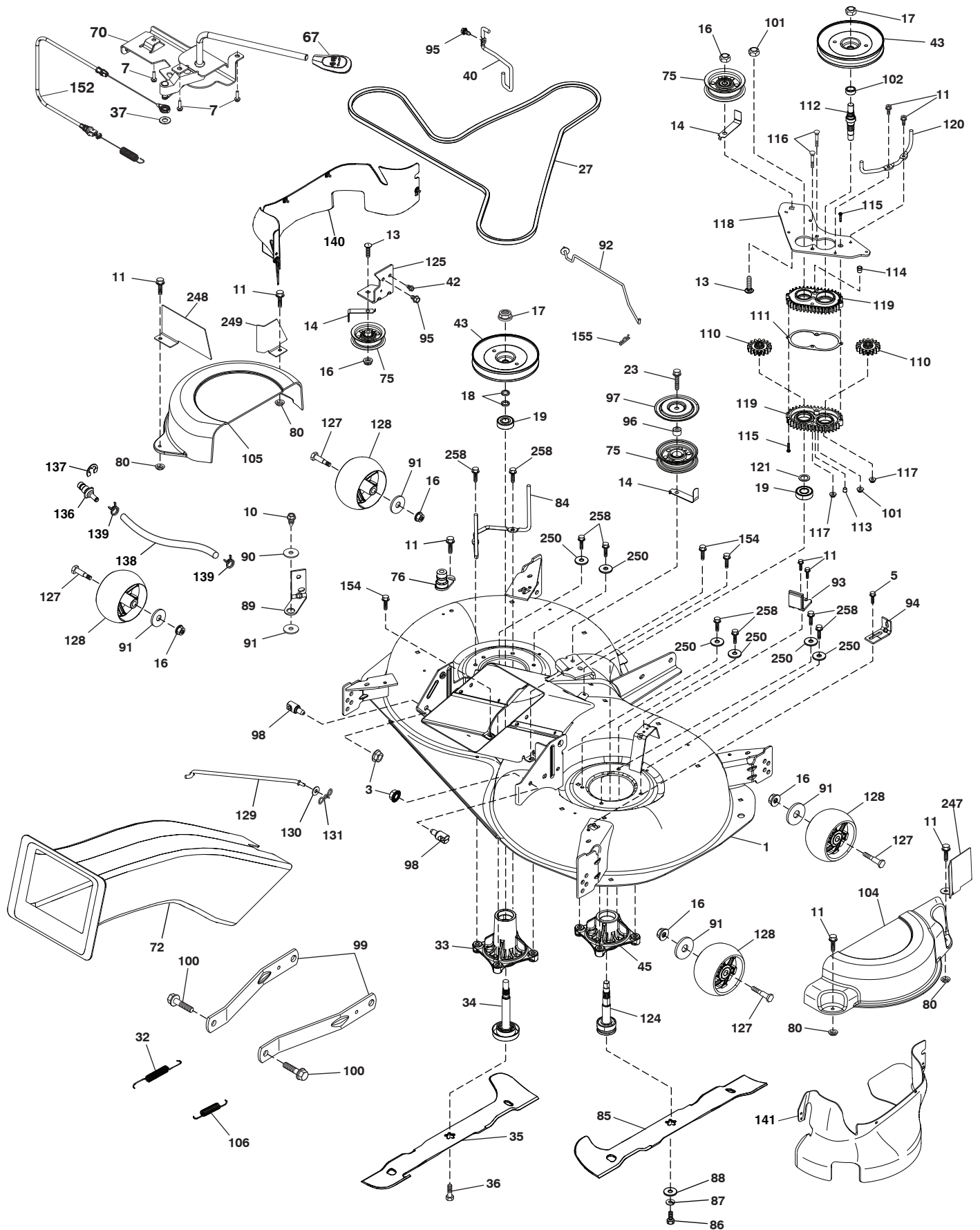

TRACTOR - MODEL NO. TC 142 (96051012500), PRODUCT NO. 960 51 01-25
MOWER DECK 44

KEY NO.	PART NO.	DESCRIPTION	KEY NO.	PART NO.	DESCRIPTION
1	587 60 24-01	Deck Weldment	112	532 44 38-52	Shaft Gearcase Adapter
3	873 90 05-00	Nut Lock Hex Flange 5/16-18	113	532 43 85-33	Plug Oil
5	817 00 05-10	Bolt 5/16-18	114	532 43 85-34	Valve Relief
7	532 41 63-58	Screw #10 x 0.750 BOS Thread	115	818 03 10-16	Screw Torx #10-24 x 1
10	817 00 06-16	Screw 3/8-16 x 1 smgml tap	116	872 11 04-14	Bolt 1/4-20 x 1.75 Gr. 5
11	532 13 77-29	Screw Thd Roll 1/4-20 X 5/8	117	873 90 04-00	Nut Hex Flange 1/4-20 unc
13	872 11 06-12	Bolt Carr Sh 3/8-16 X 1-1/2 Gr. 5	118	532 44 32-32	Arm Clutching
14	532 15 60-85	Keeper Belt Idler	119	532 43 81-66	Gearcase Subasm
16	873 90 06-00	Nut Lock FIG 3/8 - 16 unc	120	532 44 32-36	Keeper Belt RH
17	532 40 02-34	Nut Flange Lock Top	121	532 43 69-85	Washer
18	532 18 76-90	Washer Spacer Mandrel	124	581 65 07-01	Shaft Asm Mndrel Short
19	532 11 04-85	Bearing Ball Mandrel	125	532 44 04-20	Bracket Idler Chassis
23	817 49 06-28	Screw Thdrol 3/8-16 X 1-3/4	127	532 19 34-06	Bolt Shoulder 3/8-16 x 3-5/8 Gr. 5
27	532 44 58-80	V-Belt Drive	128	532 17 48-73	Wheel Gauge
32	532 40 18-72	Spring Return Deck	129	532 44 32-37	Rod Anti-Sway
33	580 79 61-01	Mandrel Asm. Tall	130	819 13 13-12	Washer 13/32 x 13/16 x 12 Ga.
34	580 85 47-01	Shaft Asm Mndrel Tall	131	532 19 42-08	Pin Cotter 5/16 Bow Tie Lock
35	581 51 79-01	Blade Mower LH	136	532 43 96-39	Washout Port Remote
36	532 19 30-03	Bolt/Washer Asm 7/16-20 unf	137	812 00 00-29	Ring Klip
37	819 13 13-16	Washer 13/32 x 13/16 x 16 Ga.	138	532 44 76-67	Washout Port Hose
40	532 19 72-58	Keeper Belt Engine LH	139	532 44 07-42	Hose Clamp
42	817 00 05-12	Screw 5/16-18 x 3/4	140	580 36 99-01	Guard French LH
43	532 44 32-39	Pulley Mandrel	141	532 44 77-03	Guard French RH
45	581 65 08-01	Mandrel Asm. Short	152	532 44 76-66	Cable Clutch Manual w/Spring
67	532 40 30-12	Handle Clutch Cable	154	532 19 98-55	Screw Thd Roll 1/4-20 x 1/2
70	532 19 99-72	Clutch Asm Manual	155	532 12 47-88	Retainer Spring
72	581 45 41-02	Chute Upper	247	581 26 34-02	Guard Steel
75	532 13 14-94	Pulley Idler Flat	248	581 26 36-02	LH Rear French Steel Guard
76	532 43 96-40	Washout Port	249	581 26 35-02	LH Front French Steel Guard
80	532 42 30-62	Palnut	250	819 11 12-12	Washer 11/32 x 3/4 x 12 Ga.
84	532 44 32-35	Keeper Belt LH Mandrel	258	584 95 39-01	Bolt Hex Washer Head .313-18 x 1.19
85	581 51 80-01	Blade Mower RH	--	580 85 60-01	Mandrel Assembly-Tall (Includes Housing (key #33), Shaft Assembly (key #34), and Bearing (key #19) Only - Pulley/Nut/Washer And Blade Bolt/Washers Not Included)
86	532 18 17-13	Bolt 3/8-24 x 1.50 Gr. 8	--	581 65 05-01	Mandrel Assembly-Short (Includes Housing (key #45), Shaft Assembly (key #124), and Bearing (key #19) Only - Pulley/Nut/Washer And Blade Bolt/Washers Not Included)
87	810 03 06-00	Washer Lock Hvy 3/8	--	587 59 93-01	Replacement Mower Complete
88	532 14 02-96	Washer Hard Blade Mower Vented			
89	532 19 72-61	Arm Brake 97 LH			
90	532 19 90-92	Spacer Retainer			
91	819 13 20-12	Washer 13/32 x 1-1/4 x 12 Ga.			
92	532 44 32-33	Rod Brake Assembly			
93	532 43 81-25	Arm Brake RH			
94	532 19 72-50	Bracket Clutch Cable			
95	817 00 06-12	Screw			
96	532 40 02-71	Spacer			
97	532 18 20-61	Shield Idler Mower			
98	532 19 51-61	Stud Fastener			
99	532 19 51-86	Arm Suspension Mower Rear			
100	532 19 65-39	Bolt Shoulder			
101	873 68 09-00	Nut Crownlock 9/16 - 18 unc			
102	532 40 25-11	Spacer Bearing Swing Plate			
104	581 71 40-01	Mandrel Cover RH			
105	532 44 47-55	Mandrel Cover LH			
106	532 19 32-16	Spring Brake Return			
110	532 41 53-56	Gear Output			
111	532 43 69-79	Gasket Gearcase			

NOTE: All component dimensions given in U.S. inches
1 inch = 25.4 mm

TRACTOR - MODEL NO. TC 142 (96051012500), PRODUCT NO. 960 51 01-25
MOWER LIFT 45

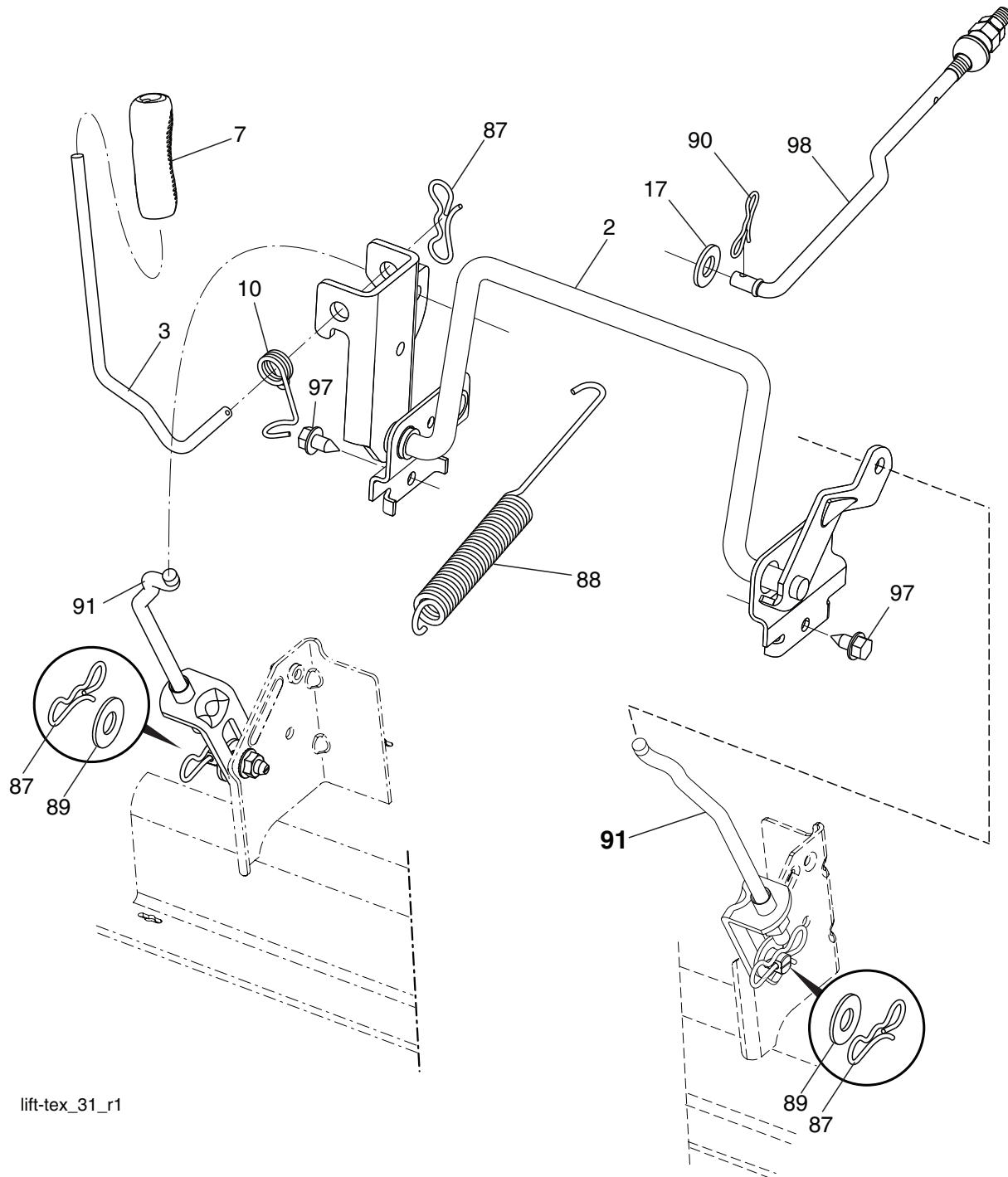

lift-tex_31_r1

KEY NO.	PART NO.	DESCRIPTION
2	532 43 69-96	Deck Lift Weldment
3	532 19 52-31	Lever Asm., Lift RH
7	580 96 23-01	Grip, Lever
10	532 19 63-14	Spring Torsion
17	819 13 13-12	Washer 13/32 x 13/16 x 12 Ga.
87	532 19 42-09	Pin Cotter 7/16 Bow Tie Lock
88	532 44 54-96	Spring Lift Assist
89	819 19 19-12	Washer Clear Zinc

KEY NO.	PART NO.	DESCRIPTION
90	532 19 42-08	Pin Cotter 5/16 Bow Tie Lock
91	532 19 51-81	Link Lift Susp Mower Rear
97	817 49 06-08	Screw 3/8-16 x 1/2
98	532 19 52-70	Link Lift Susp. Front Mower

NOTE: All component dimensions given in U.S. inches
 1 inch = 25.4 mm

**TRACTOR - MODEL NO. TC 142 (96051012500), PRODUCT NO. 960 51 01-25
SEAT ASSEMBLY 42**

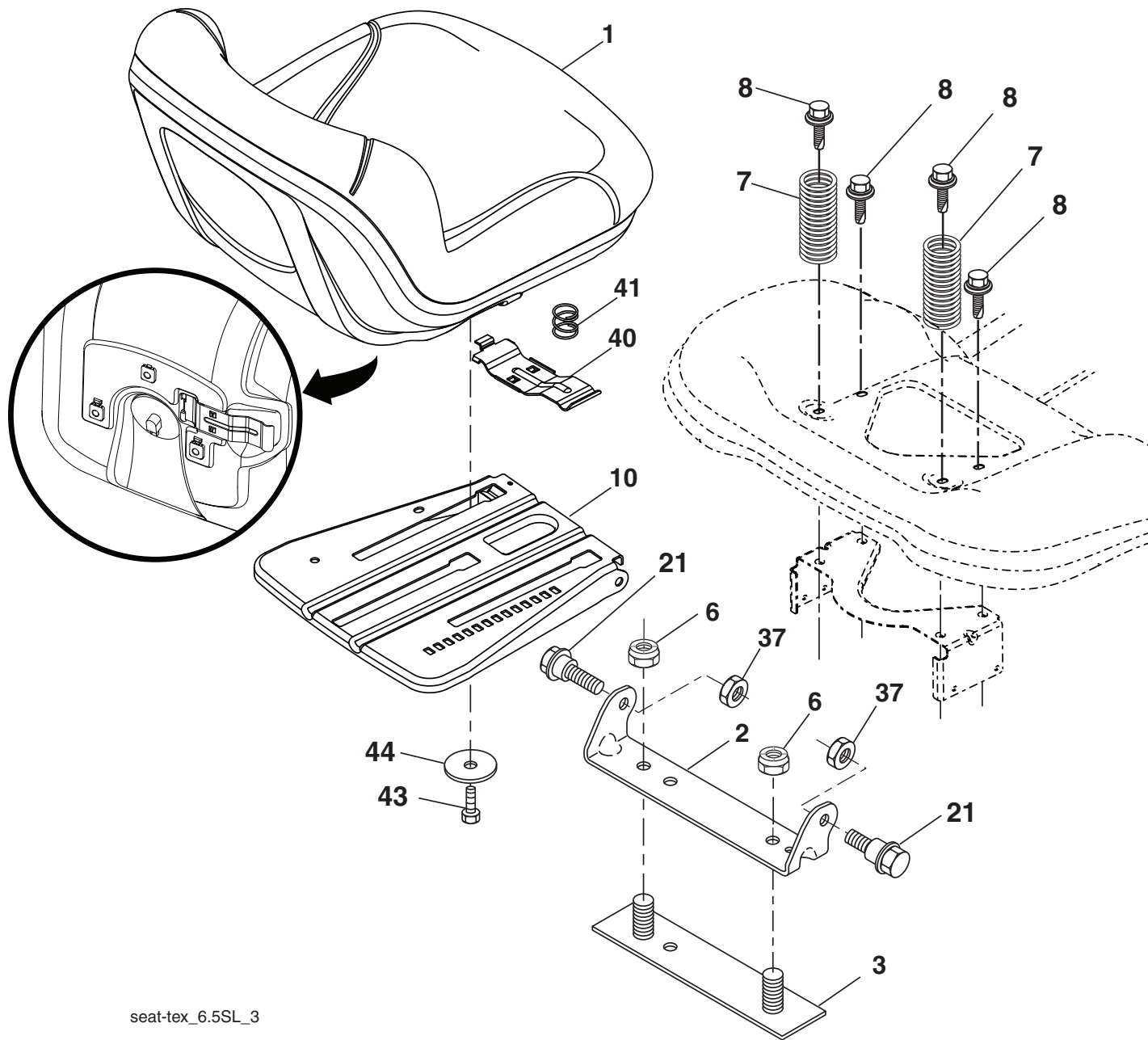

seat-tex_6.5SL_3

KEY NO.	PART NO.	DESCRIPTION
1	532 43 97-09	Seat
2	532 18 01-66	Bracket Pivot Fender
3	532 14 06-75	Strap, Asm Fender
6	873 80 06-00	Nut, Lock w/Ins. 3/8-16 unc
7	532 12 41-81	Spring, Seat Cprsn
8	532 17 18-77	Bolt 5/16-18 unc x 3/4 w/Sems
10	532 19 69-77	Pan, Seat
21	532 17 18-52	Bolt, Shoulder 5/16-18

KEY NO.	PART NO.	DESCRIPTION
37	873 80 05-00	Nut, Lock 5/16-18 unc
40	532 19 76-61	Handle Slide Seat
41	532 19 82-00	Spring Latch Seat
43	874 76 06-12	Bolt Fin Hex 3/8-16 unc x 3/4
44	819 13 38-12	Washer 13/32 x 2-3/8 x 12 Ga.

NOTE: All component dimensions given in U.S. inches
1 inch = 25.4 mm

TRACTOR - MODEL NO. TC 142 (96051012500), PRODUCT NO. 960 51 01-25
BAGGER 46

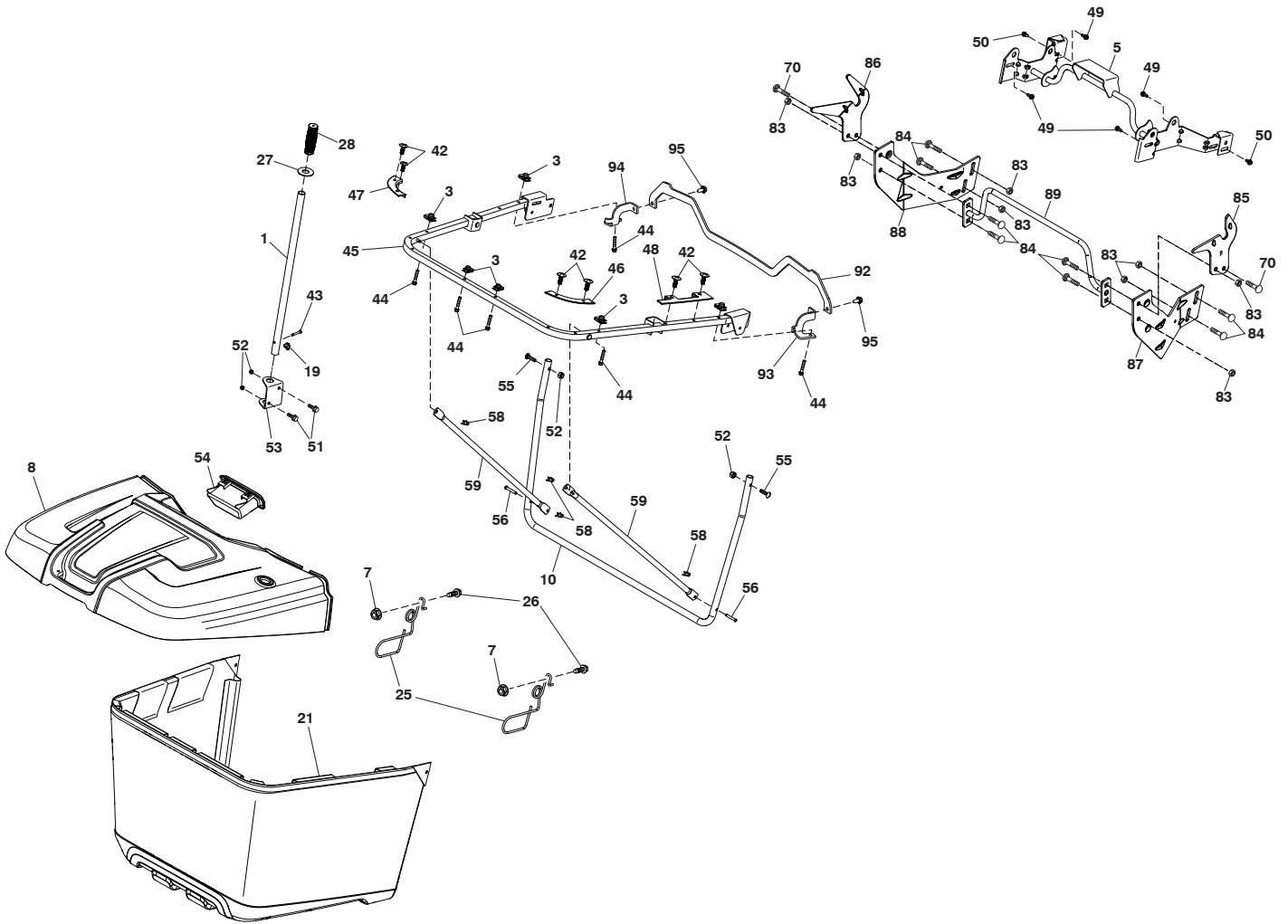

Bagger_TexCRD-Gen2_8

**TRACTOR - MODEL NO. TC 142 (96051012500), PRODUCT NO. 960 51 01-25
BAGGER 46**

KEY NO.	PART NO.	DESCRIPTION
1	532 42 86-10	Tube Handle Bagger
3	532 17 48-14	Nut Push
5	532 44 37-62	Frame Asm Top Bagger
7	873 90 04-00	Nut Hex Flange 1/4-20 unc
8	587 58 86-01	Cover Bagger
10	532 44 37-55	Frame Front
19	532 19 42-08	Cotter Pin 5/16 Bow Tie
21	532 44 59-43	Bag Asm
25	532 44 55-28	Latch Bagger
26	817 49 04-12	Screw Hexwsh Thdrol 1 1/4~20 x 3/4
27	532 44 55-29	Grommet Rubber
28	532 16 57-87	Grip Handle Black
42	532 44 04-28	Christmas Tree Clip
43	532 12 68-75	Clevis Pin
44	532 19 96-87	Bolt 1/4-20 1.50
45	532 44 37-54	Upper U Frame Weldment
46	532 44 55-41	Bagger Corner Close-Out RH
47	532 44 40-79	Bagger Corner Close-Out LH
48	532 44 40-80	Top Bagger Side Close-Out
49	532 17 18-73	Bolt Shoulder 5/16~ 18 TT
50	532 17 18-77	Bolt 5/16-18 unc x 3/4 W/SEMS
51	872 11 05-06	Bolt RDHDSQNK 5/16-18 unc x 3/4
52	873 80 05-00	Nut Lock HX W/INS 5/16-18 UNC
53	532 44 41-95	Bracket Dump Handle
54	532 44 72-18	Bagger TOP Front Handle
55	872 14 05-12	Bolt Rdhd Sq 5/16-18UNCX1 1/2
56	532 42 03-06	Pin Clevis .1830DX1.26 long
58	532 08 51-79	Clip Retainer PM
59	532 44 47-63	Bagger Spread Tube
70	817 00 06-12	Bolt 3/8-16X3/4
83	873 80 06-00	Nut Lock Hex w/Ins 3/8-16
84	872 11 06-08	Bolt RDHD SQNK 3/8-16 x 1 Gr. 5
85	581 31 44-02	Bracket RH Pivot
86	581 31 43-02	Bracket LH Pivot
87	581 31 48-02	Bracket RH
88	581 31 47-02	Bracket LH
89	581 31 51-04	Tube Asm.
92	586 05 23-02	Bracket Top Support
93	586 05 24-02	Bracket Support RH
94	586 05 25-02	Bracket Support LH
95	817 00 05-12	Screw 5/16-18 x 3/4

NOTE: All component dimensions given in U.S. inches
1 inch = 25.4 mm

