

ILLUSTRATED PARTS LIST

MFG. ID NO. 96051012700

CUSTOMER CATALOG NO. TC 242

PRODUCT NO. 960 51 01-27

47

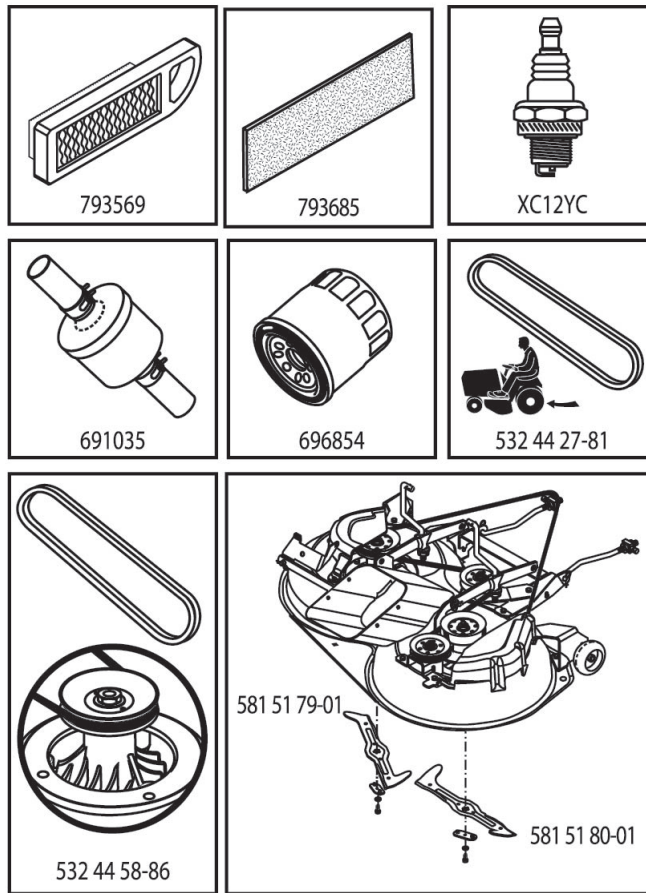

587562701

**TRACTOR - MODEL NO. TC 242 (96051012700), PRODUCT NO. 960 51 01-27
DECALS 27**

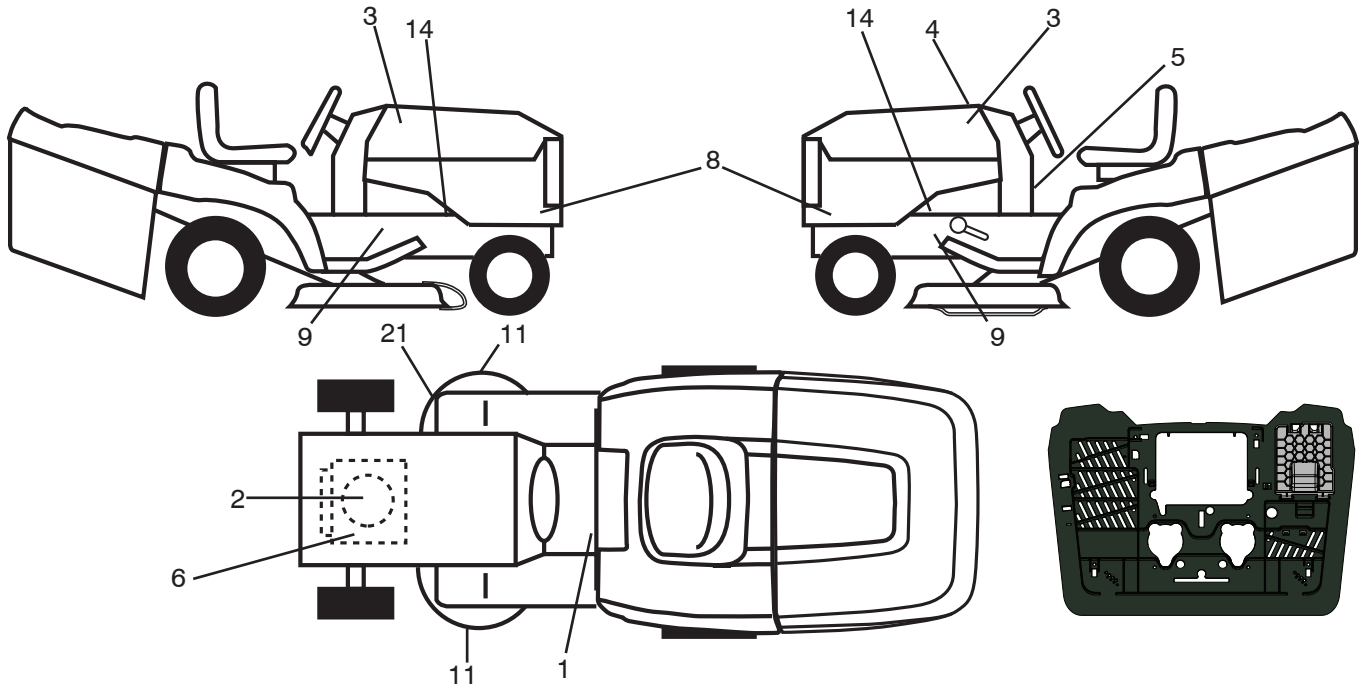

KEY PART NO.	PART NO.	DESCRIPTION
1	581 57 83-01	Decal Warning Sym. CE
2	581 57 97-01	Decal Warning Eng. Sym.
3	581 62 73-01	Decal Badge
4	587 56 27-01	Decal Replacement
5	586 06 62-01	Decal Lower Dash
6	587 38 52-01	Decal Engine
8	587 58 77-01	Decal Side Panel
9	581 57 98-01	Decal Warning Service/Fire
11	581 57 91-01	Decal Mower Cut Finger Symbol

KEY PART NO.	PART NO.	DESCRIPTION
14	581 57 96-01	Decal Chassis Hot Muffler
21	532 44 11-89	Decal Belt Schematic
--	532 44 14-09	Pad, Footrest Pad LH
--	532 44 14-10	Pad, Footrest Pad RH
--	587 58 83-40	Manual Operator's (Euro)
--	587 58 84-50	Manual Operator's (Scan)
--	587 58 84-20	Manual Operator's (E-Bloc)
--	587 58 84-30	Manual Operator's (Baltic)

WHEELS AND TIRES

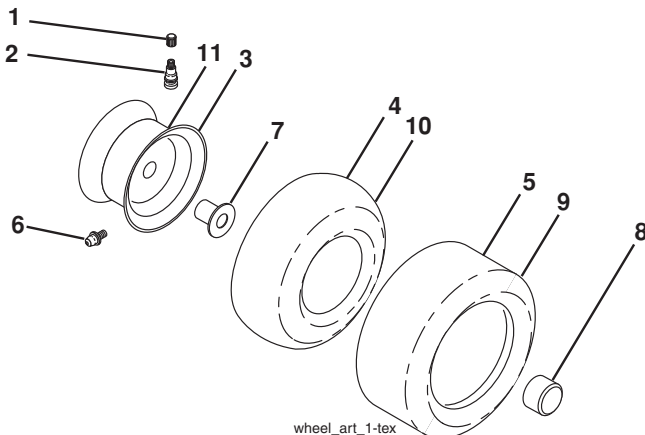

KEY PART NO.	PART NO.	DESCRIPTION
1	532 05 91-92	Cap Valve Tire
2	532 06 51-39	Stem Valve
3	532 13 83-36	Rim Front
4	532 05 99-04	Tube Front (Service Item Only)
5	532 10 62-22	Tire Front 15 x 6-6
6	532 12 49-57	Fitting Grease (Front Wheel Only)
7	532 12 49-59	Bearing Flange (Front Wheel Only)
8	532 17 50-39	Cap Axle Blk 1 50 x 1 00
9	532 42 05-31	Tire Rear 18 x 9.5-8
10	532 12 49-26	Tube Rear (Service Item Only)
11	532 13 83-37	Rim Asm 8" Rear
--	532 14 43-34	Sealant, Tire (10 oz. Tube)

NOTE: All component dimensions given in U.S. inches
1 inch = 25.4 mm

TRACTOR - MODEL NO. TC 242 (96051012700), PRODUCT NO. 960 51 01-27

SCHEMATIC **38**

SCH19

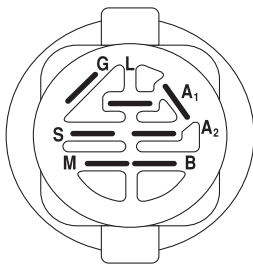
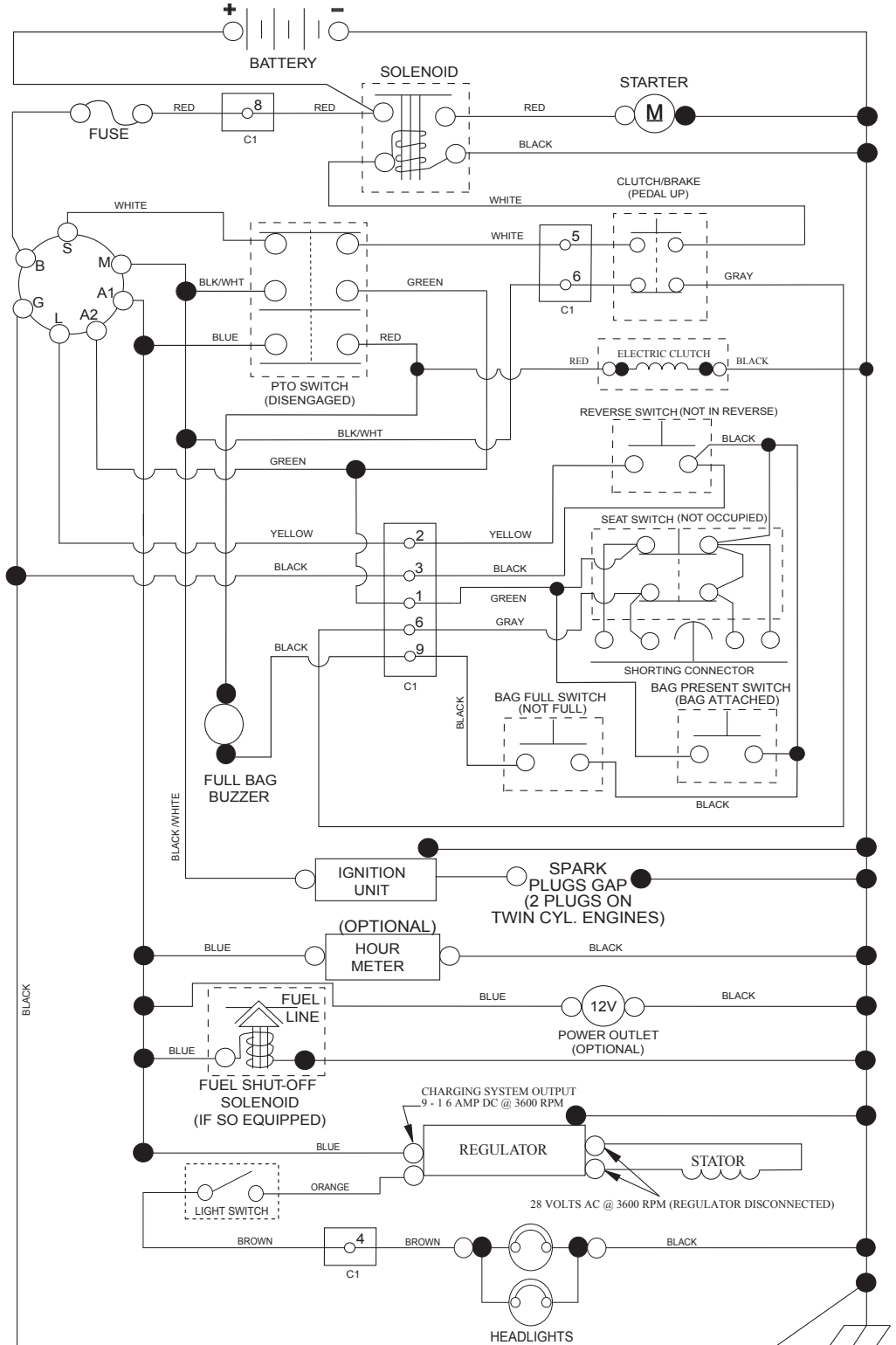

IGNITION SWITCH

POSITION	CIRCUIT	"MAKE"
OFF	M+G+A1	
RUN/OVERRIDE	B+A1	
RUN	B+A1	L+A2
START	B + S + A1	

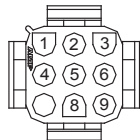

CHASSIS HARNESS CONNECTOR (C1) (MATING SIDE)

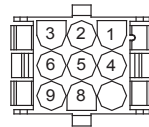

DASH HARNESS CONNECTOR (C1) (MATING SIDE)

WIRING INSULATED CLIPS
NOTE: IF WIRING INSULATED CLIPS WERE REMOVED FOR SERVICING OF UNIT, THEY SHOULD BE RE-INSTALLED TO PROPERLY SECURE YOUR WIRING.

●
NON-REMOVABLE CONNECTIONS

○
REMOVABLE CONNECTIONS

TRACTOR - MODEL NO. TC 242 (96051012700), PRODUCT NO. 960 51 01-27
ELECTRICAL 32

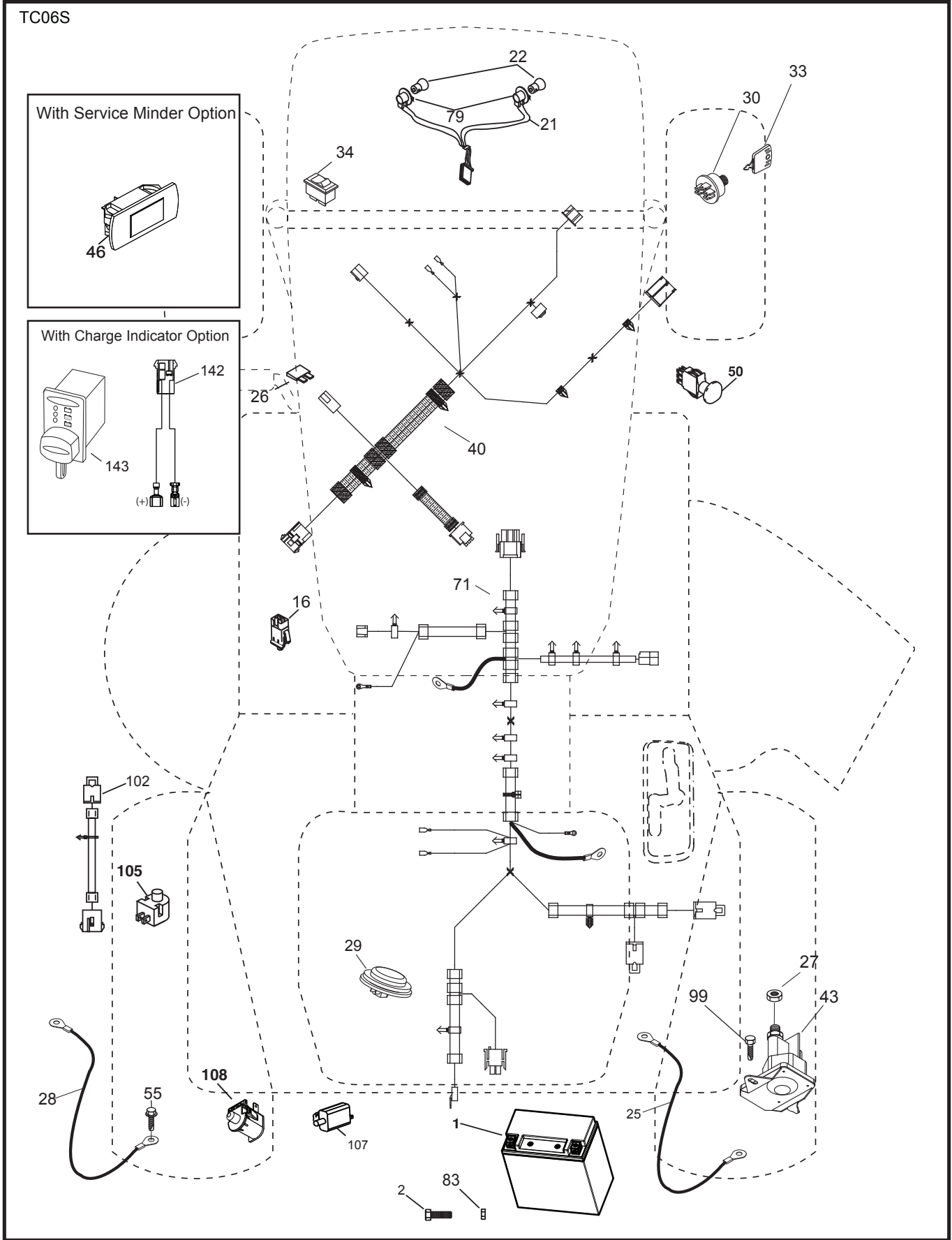

TRACTOR - MODEL NO. TC 242 (96051012700), PRODUCT NO. 960 51 01-27
ELECTRICAL 32

KEY NO.	PART NO.	DESCRIPTION
1	532 43 71-57	Battery
2	532 44 09-23	Screw Hex Hd Cap M6 x 1.12MM
16	532 17 61-38	Switch Interlock Push-In
21	532 40 02-52	Harness Socket Light w/4152J
22	532 00 41-52	Bulb Light
25	532 44 13-82	Cable Starter Red
26	532 17 51-58	Fuse
27	873 51 04-00	Nut Keps Hex 1/4-20 unc
28	532 44 13-83	Cable, Ground Black
29	532 40 15-45	Switch, Seat
30	532 19 33-50	Switch, Ign
33	532 41 19-35	Key/Chain
34	532 11 07-12	Switch Light/Reset
40	587 26 89-01	Harness Ign. Dash
43	532 19 25-07	Solenoid
46	586 16 18-01	Gauge Serviceminder Hrmtr
50	532 17 46-51	Switch PTO
55	817 06 05-12	Screw Thdrol 5/16-18 x 3/4 TYTT
71	587 26 87-01	Harness Ign. Chassis
79	532 17 52-42	Socket Asm. Bulb
83	532 43 67-74	Nut Square M6 x 1.8.5 x 11MM
99	817 72 04-08	Screw 1/4-20 x 1/2
102	532 44 12-62	Harness Pigtail Tex ROS Tuff Torq.
105	532 40 75-68	Switch Reverse
107	532 18 03-79	Switch Tall Bagger
108	532 42 10-62	Switch Snapmount
142	583 85 78-01	Charge Port Pigtail
143	532 44 80-59	Charge Port

NOTE: All component dimensions given in U.S. inches
1 inch = 25.4 mm

TRACTOR - MODEL NO. TC 242 (96051012700), PRODUCT NO. 960 51 01-27
CHASSIS AND ENCLOSURES 39

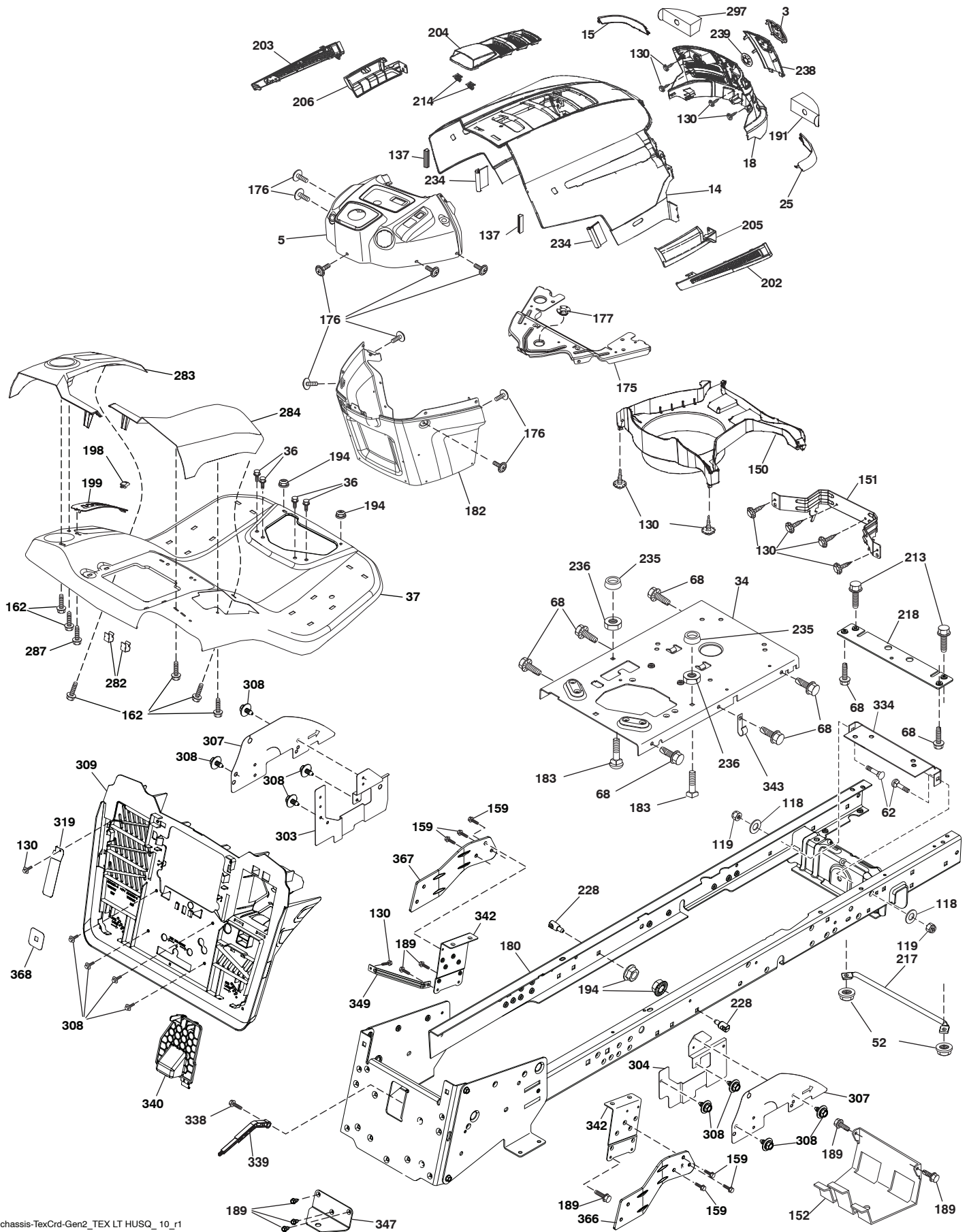

**TRACTOR - MODEL NO. TC 242 (96051012700), PRODUCT NO. 960 51 01-27
CHASSIS AND ENCLOSURES 39**

KEY PART NO. NO.	DESCRIPTION	KEY PART NO. NO.	DESCRIPTION	
3	581 05 63-01	Logo	213 874 76 05-12	Bolt 5/16-18 x 3/4
5	585 52 98-04	Dash	214 532 19 91-45	Clip Retainer Tinner
14	532 44 12-67	Hood	217 532 40 91-67	Rod Pivot
15	532 44 14-28	Lens LH	218 532 19 63-95	X-Piece Hood Stop
18	532 44 13-68	Grille	228 532 19 51-61	Stud Fastner
25	532 44 14-27	Lens RH	234 532 40 47-42	Bumper Hood
34	580 91 09-01	Plate Engine	235 532 40 61-29	Spacer Fender
36	817 06 05-12	Screw 5/16-18 x 3/4	236 873 93 05-00	Nut Lock 5/16-18 unc
37	532 44 13-69	Fender	238 532 44 13-74	Trim
52	873 68 05-00	Nut Lock 5/16-18	239 532 40 48-83	Clip
62	872 11 06-08	Bolt Rdhd Sqnk. 3/8-16 x 1 Gr. 5	282 532 41 41-10	Clip Retainer
68	817 49 05-08	Screw Thdrol 5/16-18 x 1/2	283 532 44 72-12	Console Deck Lift LH
118	819 13 13-16	Washer 13/32 x 13/16 x 16 Ga.	284 532 44 72-20	Console Shft SRD RH
119	873 68 06-00	Nut Crownlock 3/8-16 unc	287 817 60 04-06	Screw 1/4-20 x 3/8
130	532 41 63-58	Screw #10 x 0.750	297 532 40 66-65	Insert Reflective LH
137	532 40 75-90	Bumper Dash	303 587 49 31-02	Shield Chassis French LH
150	532 40 66-62	Air Duct	304 587 49 27-02	Shield Chassis French RH
151	532 40 78-07	Bracket Pivot	307 587 49 45-01	Shield Upper
152	532 19 95-35	Shield Browning	308 532 17 18-77	Bolt 5/16-18 unc x 3/4 w/Sems
159	817 00 06-12	Screw Hexwsh Thrd 3/8-16 x 3/4	309 581 32 89-11	Backplate
162	532 14 24-32	Screw	319 581 31 39-06	Lever Bagger
175	532 19 94-72	Crossmember	334 532 44 25-37	Bracket Engine
176	532 40 07-76	Screw 10-24 x 5/8	338 532 43 66-40	Bolt Shoulder
177	532 19 52-28	Bushing Steering	339 532 43 66-41	Lever Bagger Full Asm.
180	583 90 27-01	Chassis	340 581 32 90-01	Door Pnt Battery tray Tex CRD
182	532 40 71-76	Dash Lower	342 532 43 59-38	Supprt Fender
183	874 52 05-20	Bolt 5/16-18 x 1-1/4	343 532 44 07-49	Clip
189	817 00 05-12	Screw 5/16-18 x 3/4	347 532 44 28-87	Hitch Tow
191	532 41 65-01	Insert Reflective RH	349 532 43 66-06	Fuel Tank Support Bracket
194	873 90 05-00	Nut Lock Hex Flange 5/16-18	366 581 31 46-02	Bracket RH Front
198	532 44 15-52	Indicator Deck Lift	367 581 31 45-02	Bracket LH Front
199	532 41 87-39	Plate Deck Lift	368 581 42 48-01	Full Lever
202	532 44 13-42	Vent Side Hood RH	-- 532 40 09-44	Bumper
203	532 44 13-43	Vent Side Hood LH		
204	532 44 13-75	Vent Top Hood		
205	532 44 13-44	Skirt Hood Side RH		
206	532 44 13-45	Skirt Hood Side LH		

NOTE: All component dimensions given in U.S. inches
1 inch = 25.4 mm

TRACTOR - MODEL NO. TC 242 (96051012700), PRODUCT NO. 960 51 01-27
DRIVE **40**

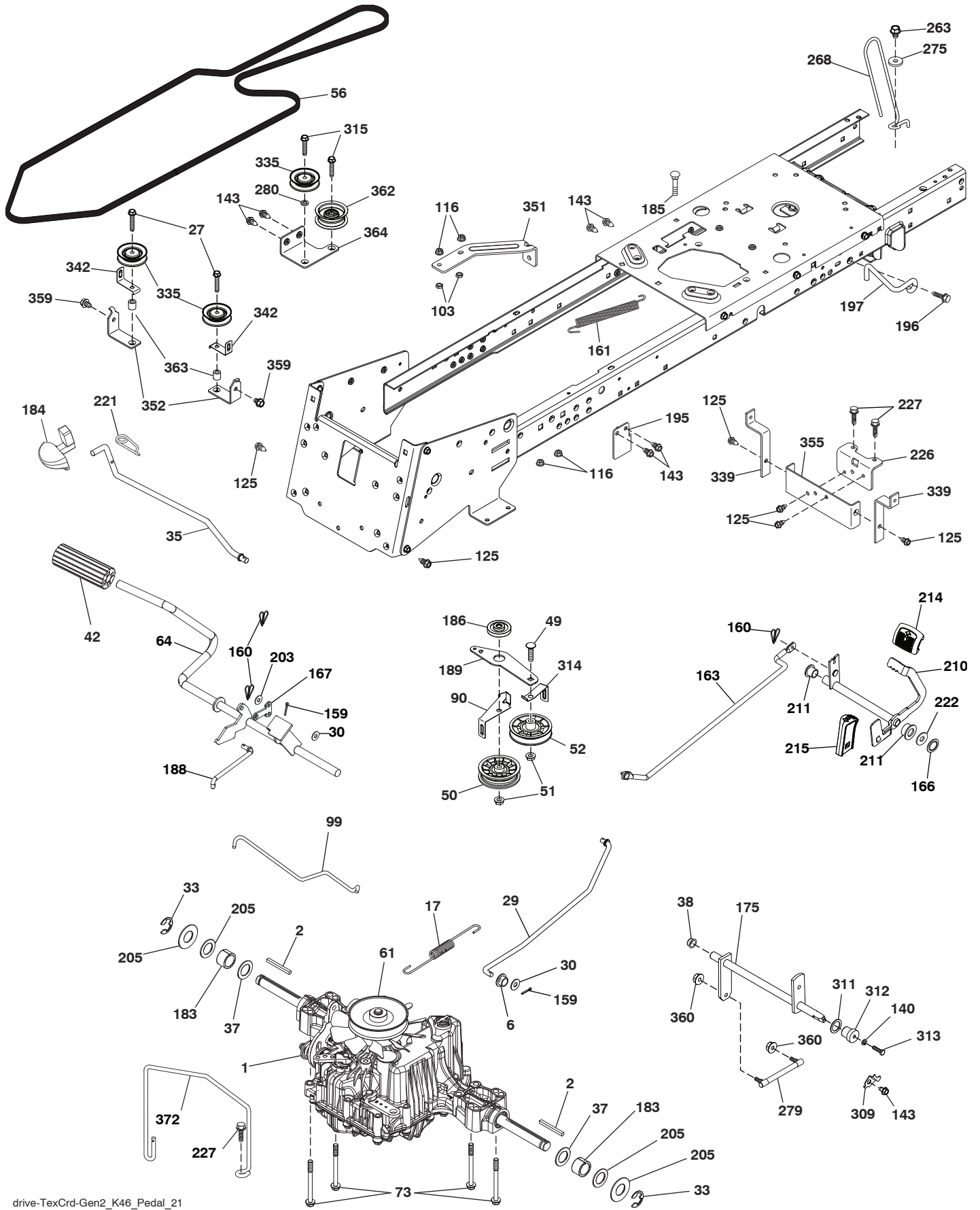

**TRACTOR - MODEL NO. TC 242 (96051012700), PRODUCT NO. 960 51 01-27
DRIVE **40****

KEY NO.	PART NO.	DESCRIPTION	KEY NO.	PART NO.	DESCRIPTION
1	---	Transaxle, Tufftorq K46DF (446488) (Order parts from transaxle manufacturer.)	189	532 43 36-11	Bellcrank Ground Drive
2	532 12 35-83	Key Square	195	580 45 69-01	Bracket Rod Brake CRD Tex
6	532 12 40-28	Bushing Snap	196	817 00 06-16	Screw
17	532 43 62-27	Spring Brake K46	197	532 19 58-04	Link Clutch
27	817 49 05-28	Screw 5/16-18 x 1-3/4	203	819 11 11-16	Washer 11/32 x 11/16 x 16 Ga.
29	532 44 27-95	Rod, Brake	205	532 12 17-48	Washer 25/32 x 1-5/8 x 16 Ga.
30	819 13 16-16	Washer	210	532 40 09-80	Rocker Asm. Pedal Control
33	812 00 00-01	Ring E	211	532 12 01-83	Bearing Nylon
35	532 40 10-31	Rod, Brake, Park	214	532 42 12-63	Pedal Forward
37	532 12 17-49	Washer 25/32 x 1-5/8 x 16 Ga.	215	586 60 65-02	Pedal Reverse
38	532 16 96-13	Nyliner Snap In	221	532 40 31-87	Retainer Spring Clip Handle
42	532 12 48-72	Cover, Foot Pedal	222	879 21 20-10	Washer 21/32 x 1-1/4 10 Ga.
49	872 11 06-14	Bolt 3/8-16 unc	226	532 40 15-64	Bracket Strap Torque
50	532 19 43-27	Idler Flat	227	817 49 05-12	Screw Thdrol 5/16-18 x 3/4
51	873 90 06-00	Lock Nut 3/8-16	263	817 00 06-12	Screw Hexwsh Thdr 3/8-16 x 3/4
52	532 19 43-26	Idler V-Groove	268	532 18 24-02	Guard Muffler RH
56	532 44 27-81	V-Belt, Drive	275	819 13 16-14	Washer 13/32 x 1 x 14 Ga.
61	532 44 51-51	Pulley Transaxle K46	279	532 44 42-83	Link Shift
64	532 19 78-65	Shaft Asm. Pedal Brake Control	280	819 11 10-12	Washer 11/32 x 5/8 x 12 Ga.
73	874 49 05-44	Bolt Hex 5/16-18 x 3.75	309	532 16 55-81	Plate Fstnr Cross Shf
90	532 44 36-05	Keeper Belt Clutching	311	532 16 98-45	Washer Nylon
99	532 44 39-47	Rod Spring Bypass	312	532 16 56-14	Hub Tapered
103	873 35 05-00	Nut Hex Jam 5/16-18 unc	313	874 78 04-16	Bolt Hex Fin 1/4-20 unc x 1 Gd5
116	873 90 05-00	Nut Lock Hex Flange 5/16-18	314	532 44 47-13	Retainer Belt
125	817 00 05-12	Screw 5/16-18 x 3/4	315	817 58 05-20	Screw Thdrol 5/16-18 x 4.25
140	810 04 04-00	Washer Lock Hvy Helical 1/4	335	532 19 95-34	Pulley-V-Idler.Grnd.Dr.Plated
143	817 49 05-08	Screw 5/16-18 x 1/2	339	532 43 68-67	Strap Torque K46
159	876 02 04-12	Pin Cotter 1/8 x 3/4	342	532 18 26-82	Keeper Belt
160	532 16 94-84	Retainer Clip	351	532 43 69-98	Bracket 97 CRD Deck Sway
161	532 10 57-09	Spring, Return, Clutch	352	532 43 56-45	Bracket Idler
163	532 44 27-93	Rod Control	355	532 43 56-69	Bracket
166	532 42 91-64	Nut Push	359	817 49 06-10	Screw 3/8-16 x 5/8
167	532 40 52-57	Latch Brake Parking	360	532 44 47-14	Nut Hex 5/16-24
175	532 42 93-59	Shaft Asm. Shift	362	532 43 68-12	Idler Flat
183	532 13 70-57	Spacer Axle	363	532 44 27-80	Spacer
184	532 44 14-07	Handle Parking Brake	364	532 44 30-32	Bracket Idler
185	872 11 06-22	Bolt 3/8-16 unc x 2-3/4	372	587 06 27-01	Keeper Belt Transaxle
186	532 19 43-21	Spacer Retainer			
188	532 19 43-23	Link Clutch			

NOTE: All component dimensions given in U.S. inches
1 inch = 25.4 mm

TRACTOR - MODEL NO. TC 242 (96051012700), PRODUCT NO. 960 51 01-27
ENGINE 24

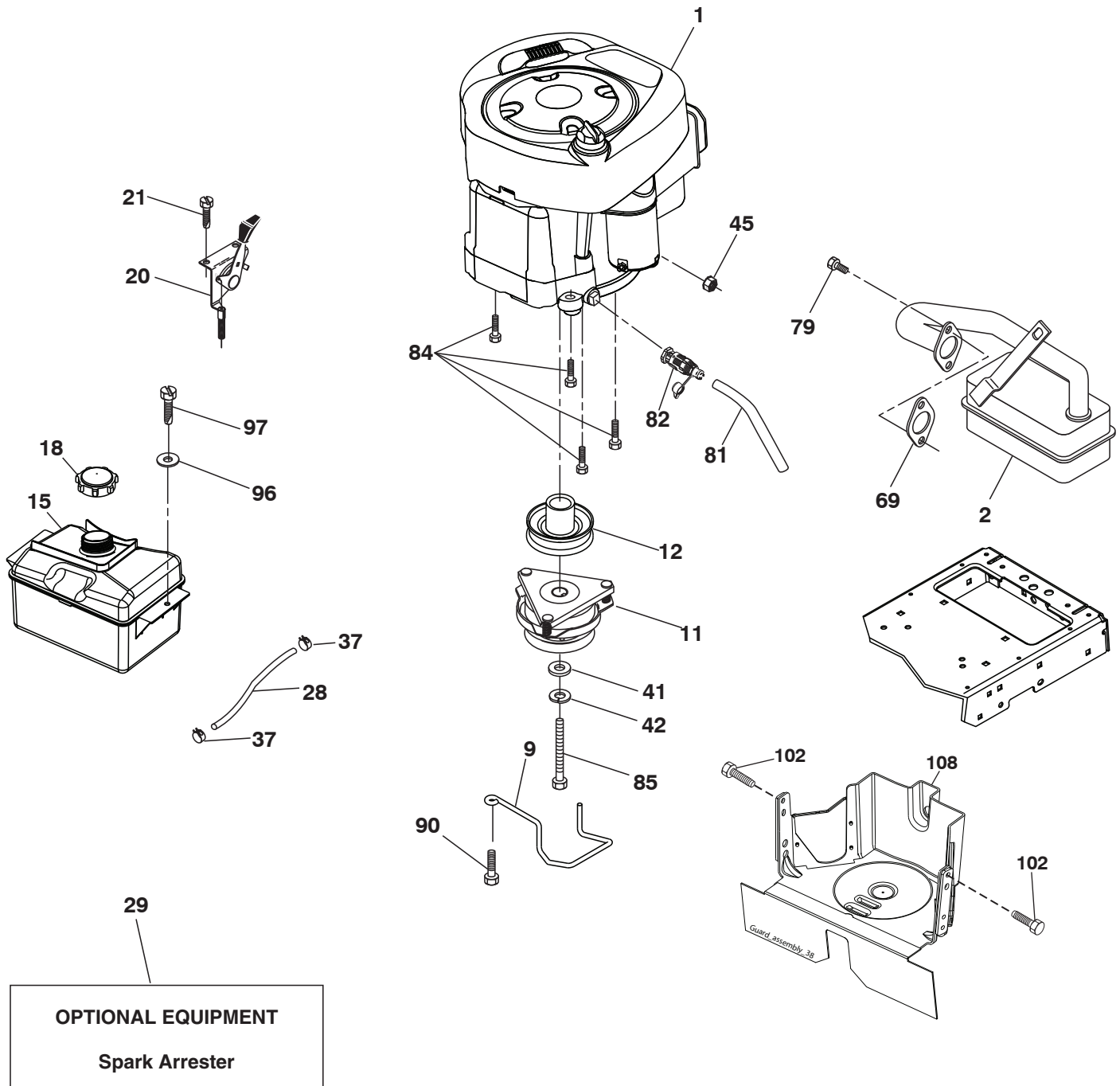

engine-tex_BS_91

**TRACTOR - MODEL NO. TC 242 (96051012700), PRODUCT NO. 960 51 01-27
ENGINE 24**

KEY NO.	PART NO.	DESCRIPTION
1	-----	Engine B&S Model No. 31U977-0001-B1 (587718701) (Order parts from engine manufacturer.)
2	532 13 73-52	Muffler
9	584 90 80-01	Keeper Belt Engine
11	532 40 00-08	Clutch
12	532 40 50-97	Pulley Engine
15	581 28 99-01	Tank Fuel
18	532 43 02-20	Fuel Cap
20	532 18 38-97	Control Throttle
21	532 41 63-58	Screw # 10 x 0.750
28	532 13 70-40	Fuel Line
29	532 13 71-80	Spark Arrester Kit
37	532 12 34-87	Clamp Hose
41	532 12 61-97	Washer
42	810 04 07-00	Washer Lock 7/16
45	873 51 04-00	Nut Keps Hex 1/4-20 unc
69	532 16 52-91	Gasket
79	532 19 23-34	Screw 5/16-18 x .75
81	532 14 84-56	Tube Drain Oil Easy
82	532 42 82-87	Valve Oil Drain
84	817 06 06-20	Screw 3/8-16 x 1-1/4
85	532 17 39-37	Bolt Hex 7/16-20 x 4 x Gr. 5-1.5 Thr
90	817 00 06-16	Screw 3/8-16 x 1
96	819 09 14-16	Washer 9/32 x 7/8 x 16 Ga.
97	817 67 04-12	Screw 1/4-20 x 3/4
102	817 06 05-16	Screw 5/16-18 x 1
108	532 42 30-41	Cover Pulley Engine

NOTE: All component dimensions given in U.S. inches
1 inch = 25.4 mm

Engine Power Rating Information

The gross power rating for individual gas engine models is labeled in accordance with SAE (Society of Automotive Engineers) code J1940 (Small Engine Power & Torque Rating Procedure), and rating performance has been obtained and corrected in accordance with SAE J1995 (Revision 2002-05). Torque values are derived at 3060 RPM; horsepower values are derived at 3600 RPM. Actual gross engine power will be lower and is affected by, among other things, ambient operating conditions and engine-to-engine variability. Given both the wide array of products on which engines are placed and the variety of environmental issues applicable to operating the equipment, the gas engine will not develop the rated gross power when used in a given piece of power equipment (actual "on-site" or net power). This difference is due to a variety of factors including, but not limited to, accessories (air cleaner, exhaust, charging, cooling, carburetor, fuel pump, etc.), application limitations, ambient operating conditions (temperature, humidity, altitude), and engine-to-engine variability. Due to manufacturing and capacity limitations, Briggs & Stratton may substitute an engine of higher rated power for this Series engine.

TRACTOR - MODEL NO. TC 242 (96051012700), PRODUCT NO. 960 51 01-27
STEERING ASSEMBLY **41**

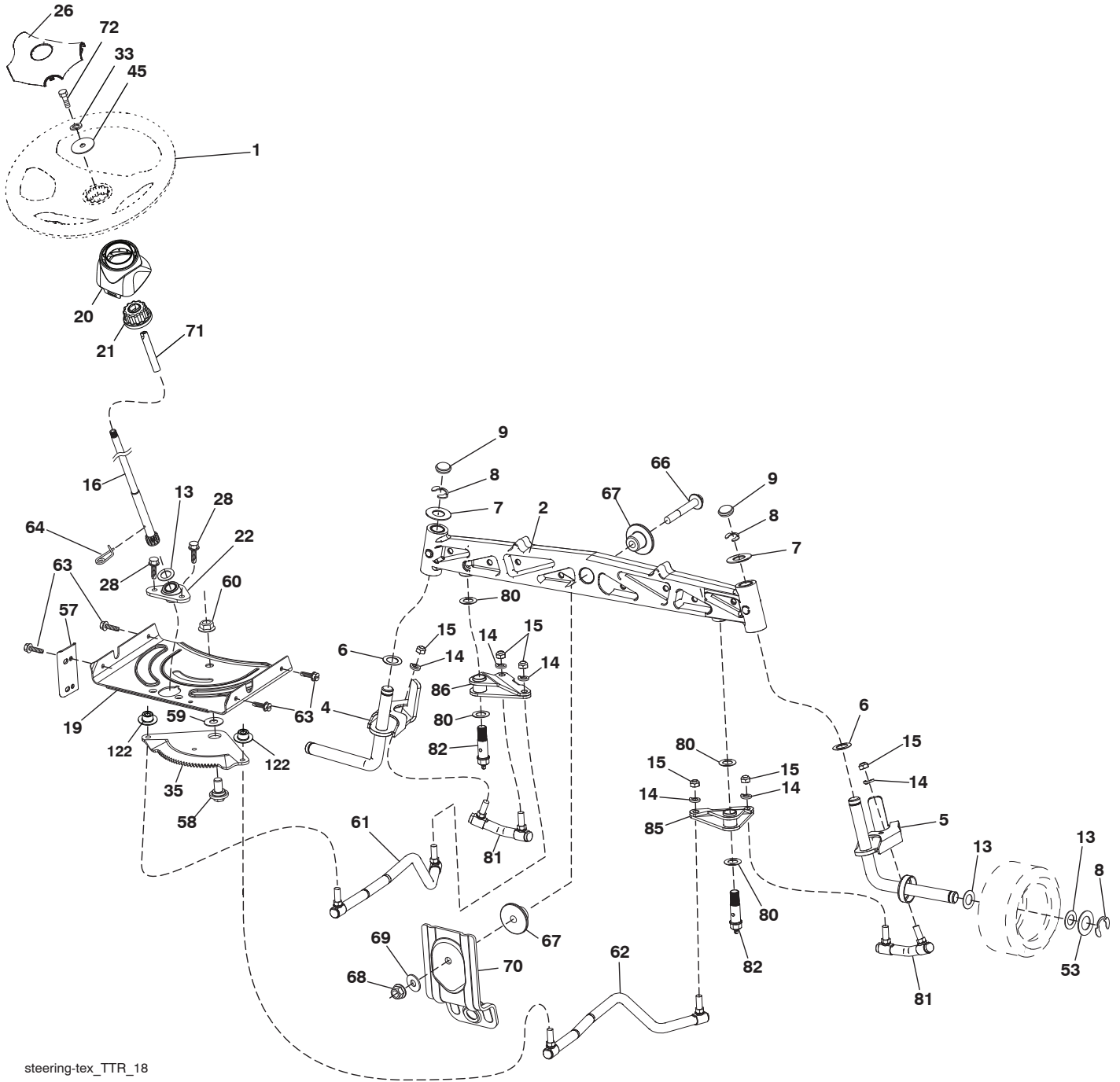

steering-tex_TTR_18

TRACTOR - MODEL NO. TC 242 (96051012700), PRODUCT NO. 960 51 01-27
STEERING ASSEMBLY 41

KEY NO.	PART NO.	DESCRIPTION
1	532 43 97-40	Wheel, Steering
2	532 43 68-70	Axle Asm., Front
4	532 43 68-73	Spindle Asm., LH
5	532 43 68-74	Spindle Asm., RH
6	532 12 49-31	Washer Thrust 0.75 x 1.23
7	532 12 17-48	Washer 25/32 x 1-5/8 x 16 Ga.
8	812 00 00-29	Ring, Klip #T5304-75
9	532 12 12-32	Cap, Spindle
13	532 12 17-49	Washer 25/32 x 1-1/4 x 16 Ga.
14	810 04 06-00	Washer, Lock 3/8
15	873 54 06-00	Nut, Crown Lock 3/8-24 unf
16	532 44 42-13	Shaft Steering
19	532 19 47-29	Plate Steering
20	532 44 14-25	Steering Boot
21	532 43 77-47	Adapter, Wheel Steering
22	532 19 48-45	Bushing, Strg. Blk
26	532 43 97-43	Insert, Wheel Steering
28	817 00 06-12	Screw 3/8-16 x 3/4
33	810 04 05-00	Washer Lock
35	532 44 07-70	Gear, Sector Plate
45	819 11 38-12	Washer 11/32 x 2-3/8 x 12 Ga.
53	532 18 89-67	Washer Hardened .793 x 1.637 x .060
57	532 40 74-65	Bracket Upstop
58	532 19 47-47	Bolt Shoulder Sector Pivot CFM
59	532 19 47-48	Washer Thrust Sector Steering
60	873 97 10-00	Nut Flange Lock 5/8-11
61	581 92 62-02	Draglink, LH
62	581 92 63-02	Draglink, RH
63	817 00 05-12	Screw 5/16-18 x 3/4
64	532 19 98-49	Retainer Clip Spring Steering
66	871 02 07-48	Bolt Hex Fghd 7/16-14 x 3 Serr
67	532 19 47-37	Bushing PM Front Axle
68	873 90 07-00	Nut Lock Flange 7/16-14 Gr. 5
69	532 19 91-62	Washer 1.5 x .505 x .118
70	585 33 88-01	Bracket Deck Susp. Front
71	532 19 07-52	Shaft Extension Steering
72	532 42 89-82	Bolt 5/16-18
80	532 00 13-70	Washer
81	532 43 68-87	Link Cross RH
82	532 44 21-47	Pivot Bolt
85	532 44 18-73	Pivot RH
86	532 44 18-72	Pivot LH
122	532 44 49-62	Cap Gear Sector

NOTE: All component dimensions given in U.S. inches
1 inch = 25.4 mm

TRACTOR - MODEL NO. TC 242 (96051012700), PRODUCT NO. 960 51 01-27
MOWER DECK 44

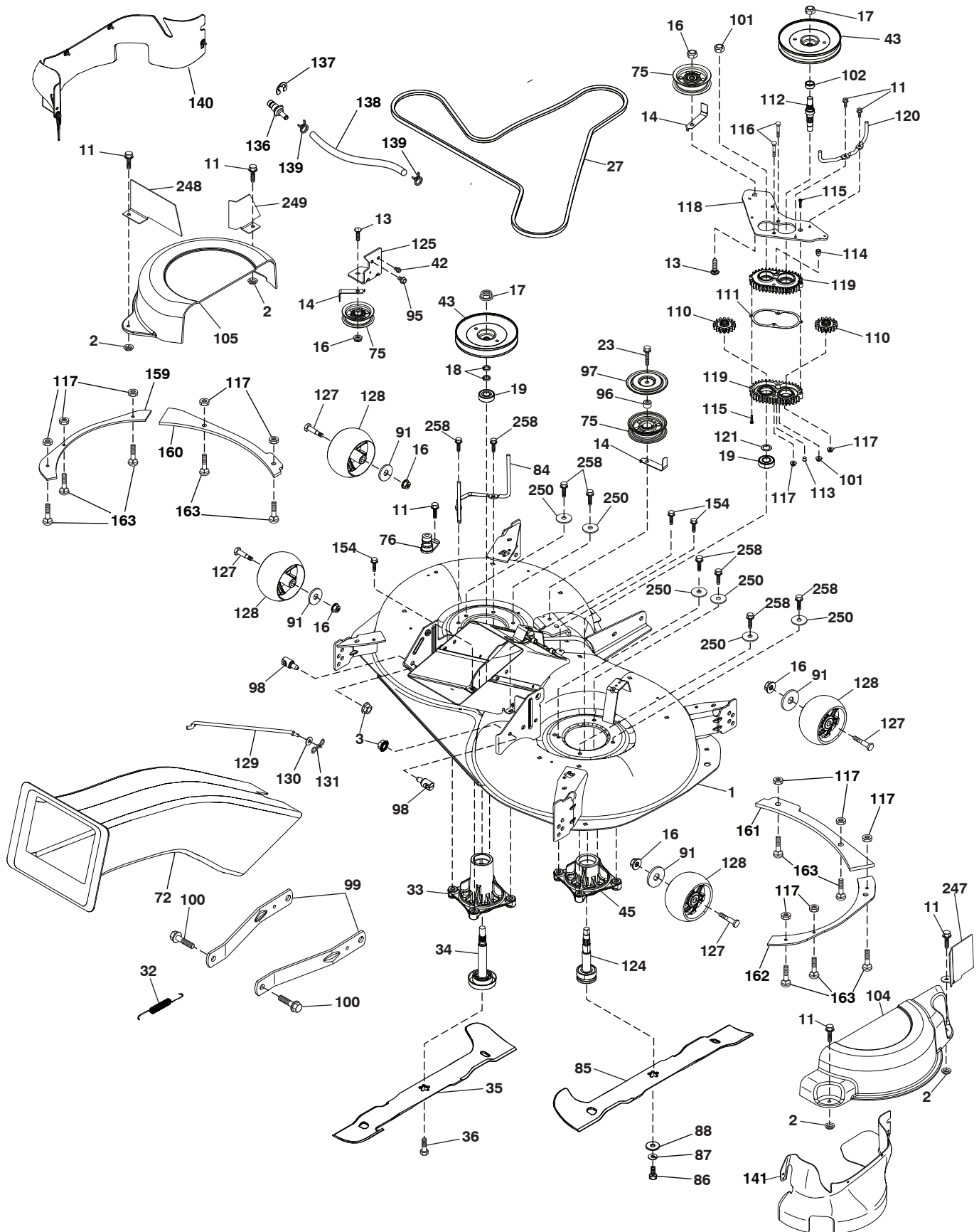

tex-deck_TexCRD-Gen2_68

TRACTOR - MODEL NO. TC 242 (96051012700), PRODUCT NO. 960 51 01-27
MOWER DECK 44

KEY NO.	PART NO.	DESCRIPTION	KEY NO.	PART NO.	DESCRIPTION
1	580 97 33-01	Deck Weldment	121	532 43 69-85	Washer
2	532 42 30-62	Palnut 1/4	124	581 65 07-01	Non Greasable Mandrel Shaft
3	873 90 05-00	Nut Lock Hex Flange 5/16 - 18	125	532 43 69-94	Bracket Idler Chassis
11	532 13 77-29	Screw Thd Roll 1/4 - 20 X 5/8	127	532 19 34-06	Bolt Shoulder 3/8-16 x 3-5/8 Gr. 5
13	872 11 06-12	Bolt Carr Sh 3/8 - 16 X 1-1/2 Gr. 5	128	532 17 48-73	Wheel Gauge
14	532 15 60-85	Keeper Belt Idler	129	532 44 32-37	Rod Anti-Sway
16	873 90 06-00	Nut Lock FIG 3/8 - 16 unc	130	819 13 13-12	Washer 13/32 x 13/16 x 12 Ga.
17	532 40 02-34	Nut Flange Lock Top	131	532 19 42-08	Pin Cotter 5/16 Bow Tie Lock
18	532 18 76-90	Washer Spacer Mandrel	136	532 43 96-39	Washout Report Remote Hook Up
19	532 11 04-85	Bearing Ball Mandrel	137	812 00 00-29	Ring Klip
23	817 49 06-28	Screw Thdrol 3/8 - 16 X 1-3/4	138	532 44 76-67	Hose Washout Port
27	532 44 58-86	V-Belt Drive	139	532 44 07-42	Hose 3/8 Clamp
32	532 44 62-05	Spring Drive	140	580 36 99-01	Guard Sub Asm. LH
33	580 79 61-01	Mandrel Asm. Tall	141	532 44 77-03	Guard Sub Asm. RH
34	580 85 47-01	Shaft Asm Mndrl N/Greasable	154	532 19 98-55	Screw Thd Roll 1/4-20 x 1/2
35	581 51 79-01	Blade Mower LH	159	585 30 95-05	Plate 107 CRD LH Side
36	532 19 30-03	Bolt/Washer Asm 7/16 - 20 unf	160	585 30 94-05	Plate 107 CRD LH Front
42	817 00 05-12	Screw 5/16-18 x 3/4	161	585 31 60-05	Plate 107 CRD RH Front
43	532 44 32-39	Pulley Mandrel	162	585 31 61-05	Plate 107 CRD RH Side
45	581 65 08-01	Mandrel Asm. Short	163	872 11 04-06	Bolt
72	581 45 41-02	Chute Upper	247	581 26 34-02	Guard Steel
75	532 13 14-94	Pulley Idler Flat	248	581 26 36-02	LH Rear Steel Guard
76	532 43 96-40	Washout Port	249	581 26 35-02	LH Rear Steel Guard
84	532 44 32-35	Keeper Belt LH Mandrel	250	819 11 12-12	Washer 11/32 x 3/4 x 12 Ga.
85	581 51 80-01	Blade Mower RH	258	584 95 39-01	Bolt Hex Wsh Hd 3/13-18 x 1.19
86	532 18 17-13	Bolt 3/8-24 x 1.50 Gr. 8	--	580 85 60-01	Mandrel Assembly Tall (Includes Housing (key # 33), Shaft Assembly (key # 34), And Bearing Only (key # 19) - Pulley/Nut/Washer And Blade Bolt/Washers Not Included.)
87	810 03 06-00	Washer Lock Hvy. 3/8			
88	532 14 02-96	Washer Hard			
91	819 13 20-12	Washer 13/32 x 1-1/4 x 12 Ga.			
95	817 00 06-12	Screw 3/8-16 x 3/4			
96	532 40 02-71	Spacer			
97	532 18 20-61	Shield Idler Mower	--	581 65 05-01	Mandrel Assembly Short (Includes Housing (key # 45), Shaft Assembly (key # 124), And Bearing Only (key # 19) - Pulley/Nut/Washer And Blade Bolt/Washers Not Included.)
98	532 19 51-61	Stud Fastener			
99	532 19 51-86	Arm Suspension Mower Rear			
100	532 19 65-39	Bolt Shoulder			
101	873 68 09-00	Nut Crownlock 9/16 - 18 unc			
102	532 40 25-11	Spacer Bearing Swing Plate			
104	581 71 40-01	Mandrel Cover RH	--	587 59 62-01	Replacement Mower Complete
105	532 44 47-55	Mandrel Cover LH			
110	532 41 53-56	Gear Output			
111	532 43 69-79	Gasket Gearcase			
112	532 44 38-52	Shaft Gearcase Adapter			
113	532 43 85-33	Plug Oil			
114	532 43 85-34	Valve Relief			
115	818 03 10-16	Screw Torx #10-24 x 1			
116	872 11 04-14	Bolt 1/4-20 x 1.75 Gr. 5			
117	873 90 04-00	Nut Hex Flange 1/4-20 unc			
118	532 44 32-32	Arm Clutching			
119	532 43 81-66	Gearcase Subasm			
120	532 44 32-36	Keeper Belt RH			

NOTE: All component dimensions given in U.S. inches
1 inch = 25.4 mm

TRACTOR - MODEL NO. TC 242 (96051012700), PRODUCT NO. 960 51 01-27
MOWER LIFT 45

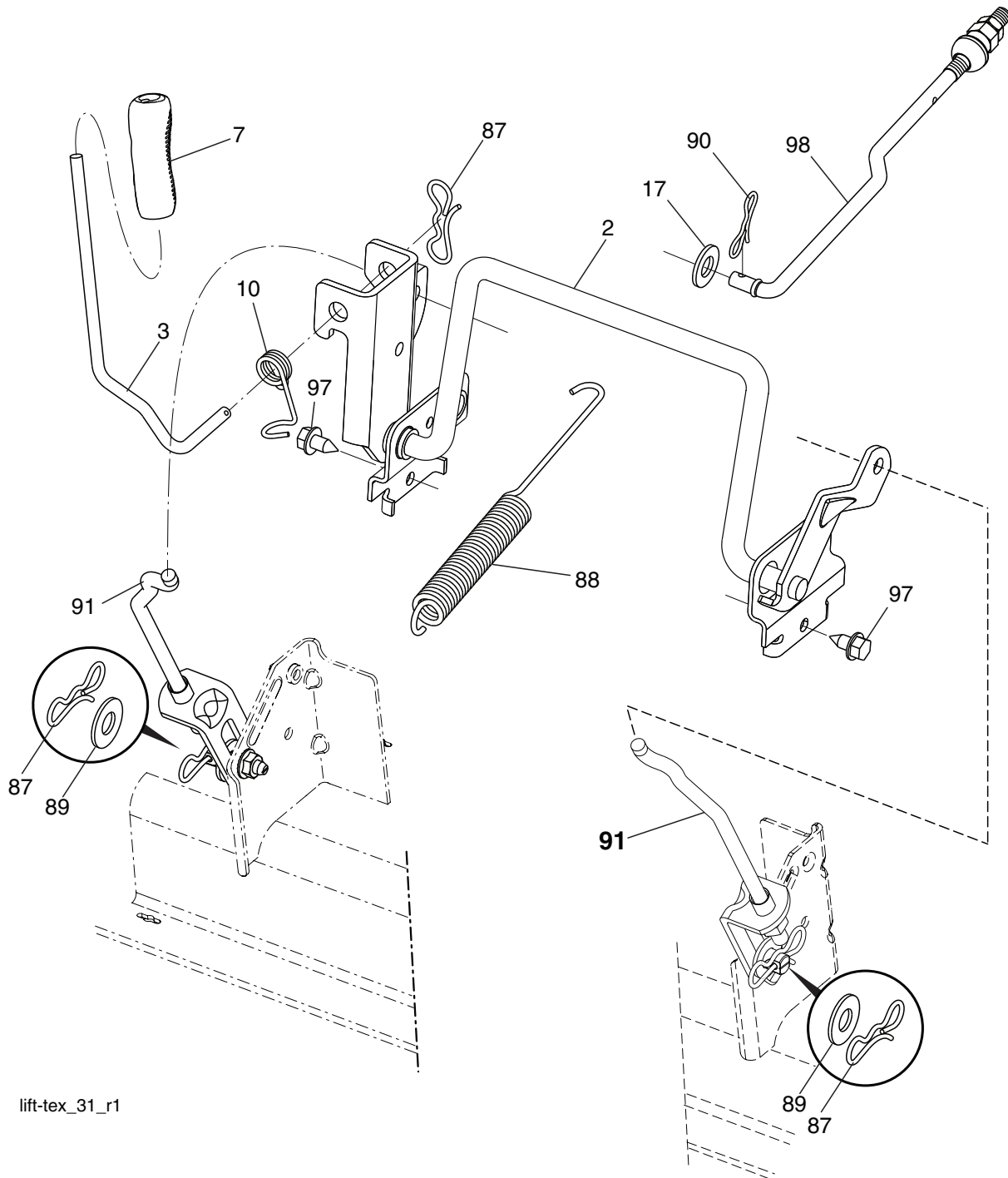

lift-tex_31_r1

KEY NO.	PART NO.	DESCRIPTION
2	532 43 69-96	Deck Lift Weldment
3	532 19 52-31	Lever Asm., Lift RH
7	580 96 23-01	Grip, Lever
10	532 19 63-14	Spring Torsion
17	819 13 13-12	Washer 13/32 x 13/16 x 12 Ga.
87	532 19 42-09	Pin Cotter 7/16 Bow Tie Lock
88	532 44 54-96	Spring Lift Assist
89	819 19 19-12	Washer Clear Zinc

KEY NO.	PART NO.	DESCRIPTION
90	532 19 42-08	Pin Cotter 5/16 Bow Tie Lock
91	532 19 51-81	Link Lift Susp Mower Rear
97	817 49 06-08	Screw 3/8-16 x 1/2
98	532 19 52-70	Link Lift Susp. Front Mower

NOTE: All component dimensions given in U.S. inches
 1 inch = 25.4 mm

TRACTOR - MODEL NO. TC 242 (96051012700), PRODUCT NO. 960 51 01-27
SEAT ASSEMBLY 42

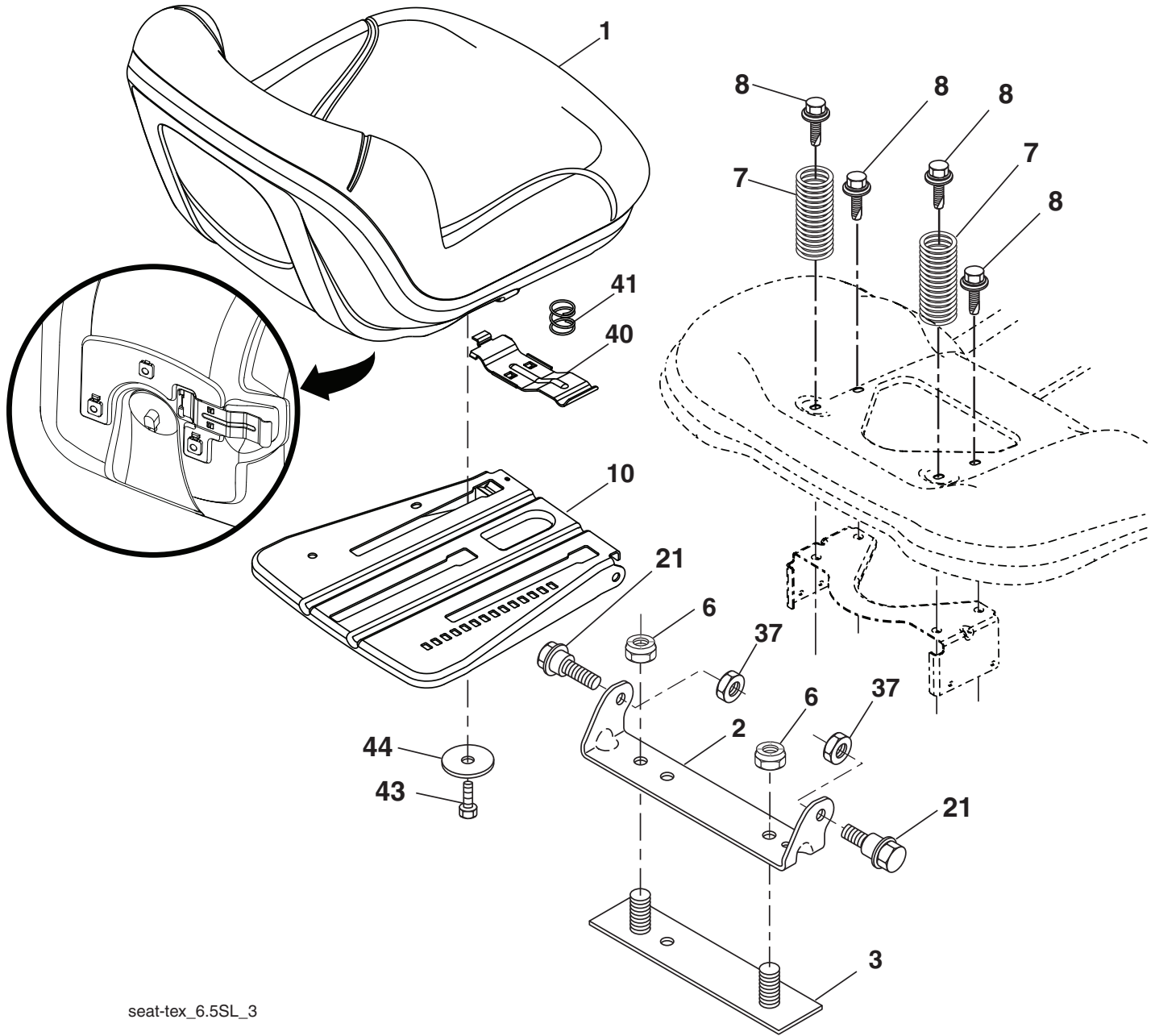

seat-tex_6.5SL_3

KEY NO.	PART NO.	DESCRIPTION
1	532 43 98-19	Seat
2	532 18 01-66	Bracket Pivot Fender
3	532 14 06-75	Strap, Asm Fender
6	873 80 06-00	Nut, Lock w/Ins. 3/8-16 unc
7	532 12 41-81	Spring, Seat Cprsn
8	532 17 18-77	Bolt 5/16-18 unc x 3/4 w/Sems
10	532 19 69-77	Pan, Seat
21	532 17 18-52	Bolt, Shoulder 5/16-18

KEY NO.	PART NO.	DESCRIPTION
37	873 80 05-00	Nut, Lock 5/16-18 unc
40	532 19 76-61	Handle Slide Seat
41	532 19 82-00	Spring Latch Seat
43	874 76 06-12	Bolt Fin Hex 3/8-16 unc x 3/4
44	819 13 38-12	Washer 13/32 x 2-3/8 x 12 Ga.

NOTE: All component dimensions given in U.S. inches
 1 inch = 25.4 mm

TRACTOR - MODEL NO. TC 242 (96051012700), PRODUCT NO. 960 51 01-27
BAGGER **46**

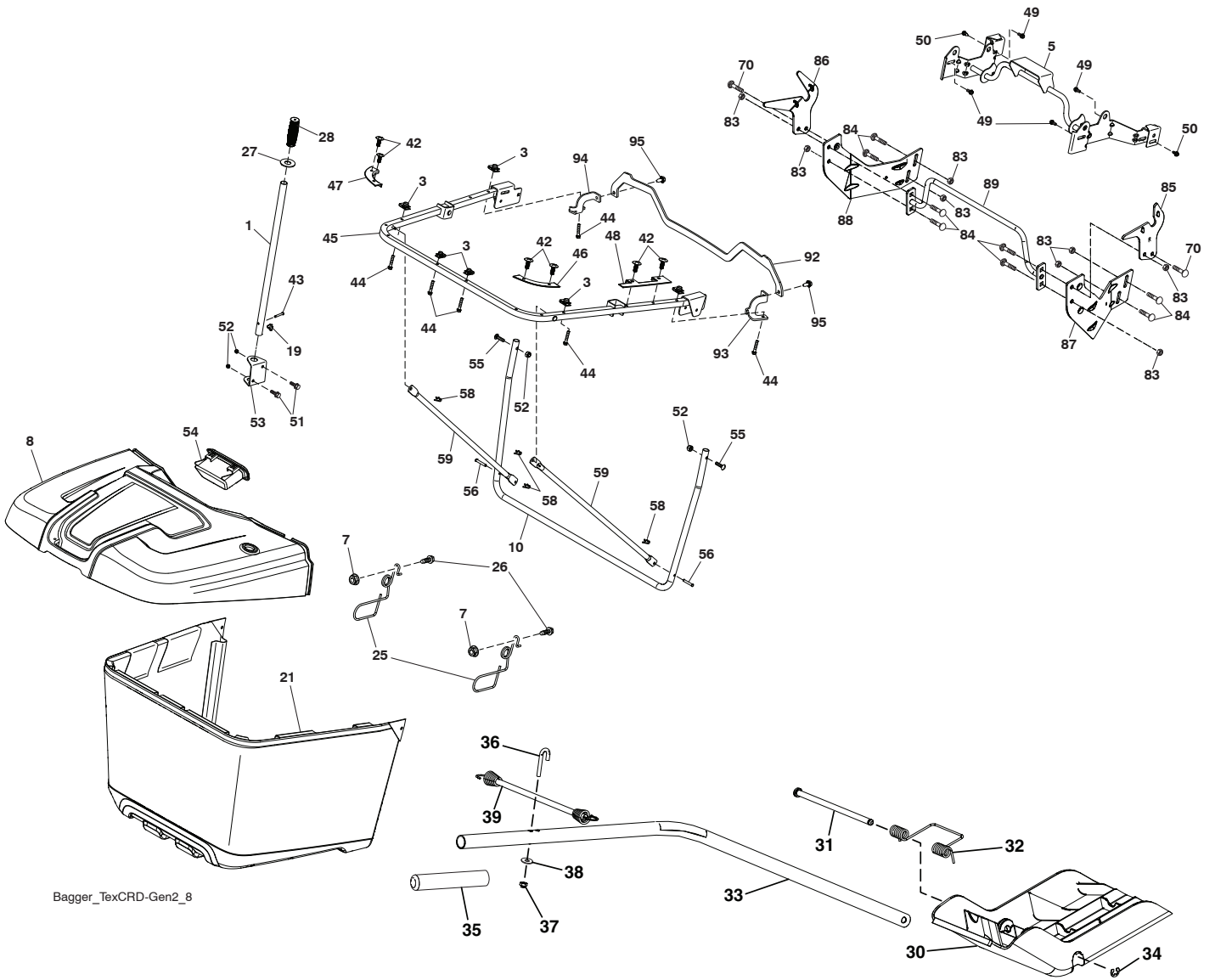

Bagger_TexCRD-Gen2_8

**TRACTOR - MODEL NO. TC 242 (96051012700), PRODUCT NO. 960 51 01-27
BAGGER **46****

KEY NO.	PART NO.	DESCRIPTION
1	532 42 86-10	Tube Handle Bagger
3	532 17 48-14	Nut Push
5	532 44 37-62	Frame Asm Top Bagger
7	873 90 04-00	Nut Hex Flange 1/4-20 unc
8	587 58 86-01	Cover Bagger
10	532 44 37-55	Frame Front
19	532 19 42-08	Cotter Pin 5/16 Bow Tie
21	532 44 59-43	Bag Asm
25	532 44 55-28	Latch Bagger
26	817 49 04-12	Screw Hexwsh Thdrol 1 14~20 x 3/4
27	532 44 55-29	Grommet Rubber
28	532 16 57-87	Grip Handle Black
30	532 43 74-52	Plug
31	532 43 58-61	Pin Hinge
32	532 43 74-54	Spring Double Torsion
33	532 43 84-51	Shaft Mulch Plug
34	532 43 79-88	E-Ring 5/16
35	532 43 91-39	Grip Mulch Plug
36	532 43 90-98	Bolt J
37	532 06 91-80	Nut Lock #10-24 unc
38	819 07 08-18	Washer 7/32 x 1/2
39	532 43 92-42	Bungee
42	532 44 04-28	Christmas Tree Clip
43	532 12 68-75	Rivet
44	532 19 96-87	Bolt 1/4-20 1.50
45	532 44 37-54	Upper U Frame Weldment
46	532 44 55-41	Bagger Corner Close-Out RH
47	532 44 40-79	Bagger Corner Close-Out LH
48	532 44 40-80	Top Bagger Side Close-Out

KEY NO.	PART NO.	DESCRIPTION
49	532 17 18-73	Bolt Shoulder 5/16~ 18 TT
50	532 17 18-77	Bolt 5/16-18 unc x 3/4 W/SEMS
51	872 11 05-06	Bolt RDHDSQNK 5/16-18 unc x 3/4
52	873 80 05-00	Nut Lock HX W/INS 5/16-18 UNC
53	532 44 41-95	Bracket Dump Handle
54	532 44 72-18	Bagger TOP Front Handle
55	872 14 05-12	Bolt Rdhd Sq 5/16-18UNCX1 1/2
56	532 42 03-06	Pin Clevis .1830DX1.26 long
58	532 08 51-79	Clip Retainer PM
59	532 44 47-63	Bagger Spread Tube
70	817 00 06-12	Bolt 3/8-16X3/4
83	873 80 06-00	Nut Lock Hex w/Ins 3/8-16
84	872 11 06-08	Bolt RDHD SQNK 3/8-16 x 1 Gr. 5
85	581 31 44-02	Bracket RH Pivot
86	581 31 43-02	Bracket LH Pivot
87	581 31 48-02	Bracket RH
88	581 31 47-02	Bracket LH
89	581 31 51-04	Tube Asm.
92	586 05 23-02	Bracket Top Support
93	586 05 24-02	Bracket Support RH
94	586 05 25-02	Bracket Support LH
95	817 00 05-12	Screw 5/16-18 x 3/4

NOTE: All component dimensions given in U.S. inches
1 inch = 25.4 mm

