

# **ILLUSTRATED PARTS LIST**

**MFG. ID NO. 96041023704**

**CUSTOMER CATALOG NO. YTH2242TDRF**

**PRODUCT NO. 960 41 02-37**

**TRACTOR - - MODEL NO. YTH2242TDRF (96041023704), PRODUCT NO. 960 41 02-37  
DECALS 27**

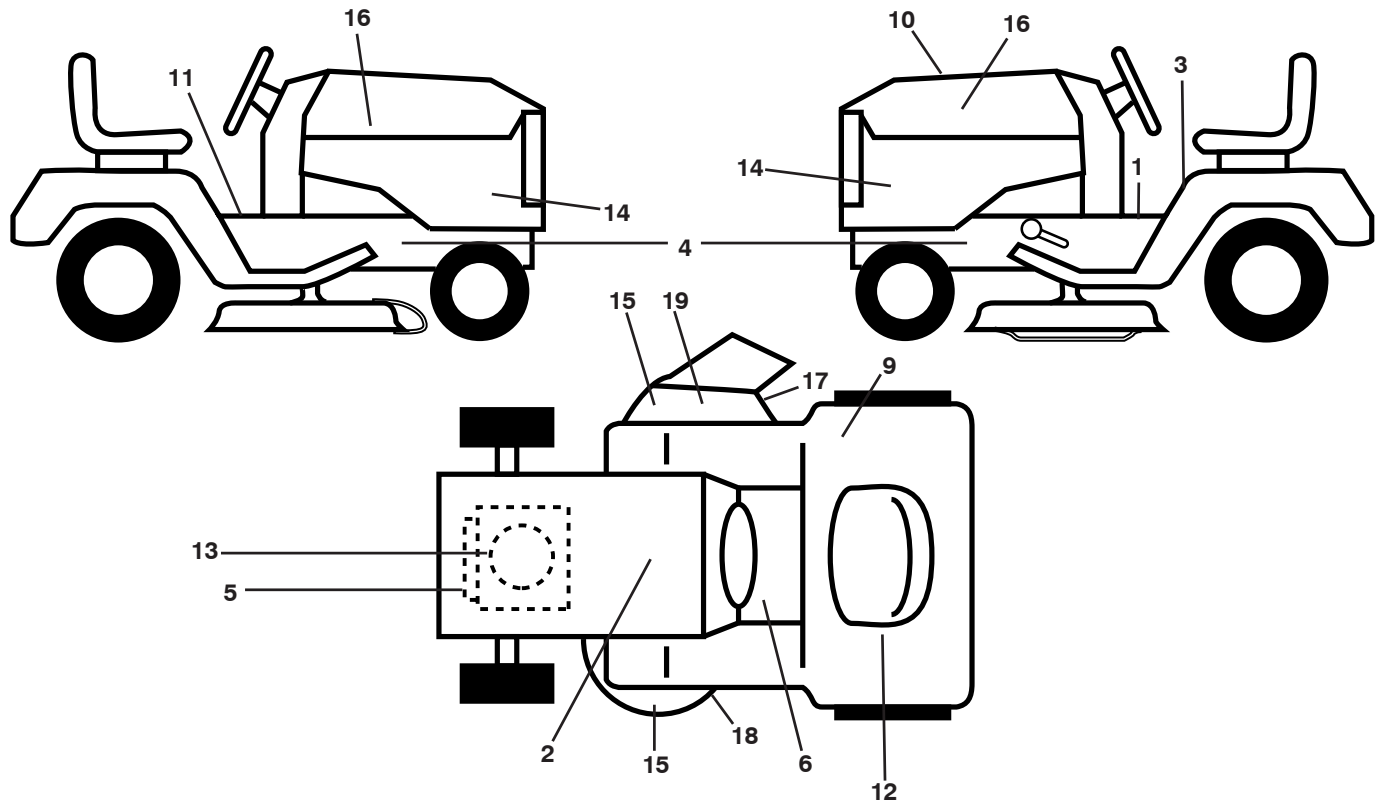

KEY NO.	PART NO.	DESCRIPTION
1	581 57 80-01	Decal, Saddle
2	532 14 50-05	Decal, Battery
3	581 57 81-01	Decal, Warn. Sym.
4	581 57 96-01	Decal, Chassis Hot
5	587 21 62-01	Decal, Engine HP
6	581 72 40-01	Decal, Fender Saddle Brake Clutch
9	586 80 03-01	Decal, Oper. Cruise
10	587 56 34-01	Decal, Replacement
11	581 72 40-01	Decal, Brake/Clutch
12	587 01 51-01	Decal, Warning Reserve Fuel
13	581 57 97-01	Decal, Engine

KEY NO.	PART NO.	DESCRIPTION
14	532 44 40-01	Decal, Panel Side
15	581 72 43-01	Decal, No Step
16	581 62 73-01	Decal, Hood Logo Badge
17	581 72 44-01	Decal, Warning
18	581 58 00-02	Decal, V-Belt Sch.
--	584 90 46-01	Decal, Deck/Deflect. Warning
--	581 72 46-01	Decal, Drawbar
--	581 72 48-01	Decal, Bypass
--	532 43 98-82	Pad, Footrest, LH
--	532 43 98-81	Pad, Footrest, RH
--	587 26 91-26	Manual, Operator's (English)

**WHEELS AND TIRES**

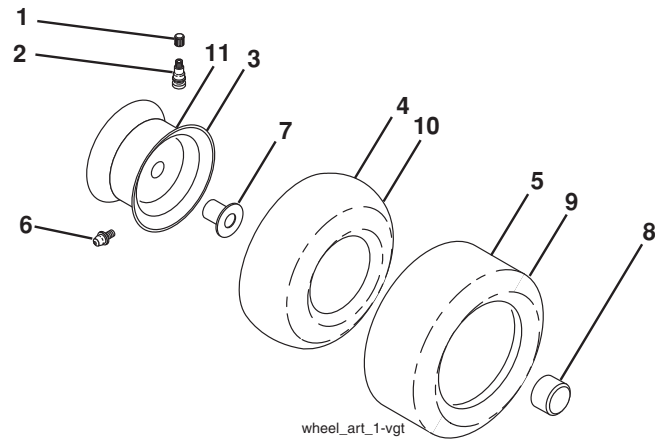

KEY NO.	PART NO.	DESCRIPTION
1	532 05 91-92	Cap, Valve, Tire
2	532 06 51-39	Stem, Valve
3	532 18 18-39	Rim Assembly, Front
4	532 00 81-34	Tube, Front (Service Item Only)
5	532 10 62-30	Tire, Front 16 x 6.5-8
6	532 12 49-57	Fitting, Grease (Front Wheel Only)
7	532 12 49-59	Bearing, Flange (Front Wheel Only)
8	532 17 50-39	Cap, Axle
9	532 12 20-82	Tire, Rear 20 x 10-8
10	532 12 49-26	Tube, Rear (Service Item Only)
11	532 13 83-37	Rim Assembly, Rear
--	532 14 43-34	Sealant, Tire (10 oz. Tube)

**NOTE:** All component dimensions given in U.S. inches  
1 inch = 25.4 mm

# TRACTOR - - MODEL NO. YTH2242TRF (96041023704), PRODUCT NO. 960 41 02-37 SCHEMATIC 38

SCH12

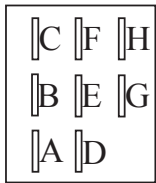
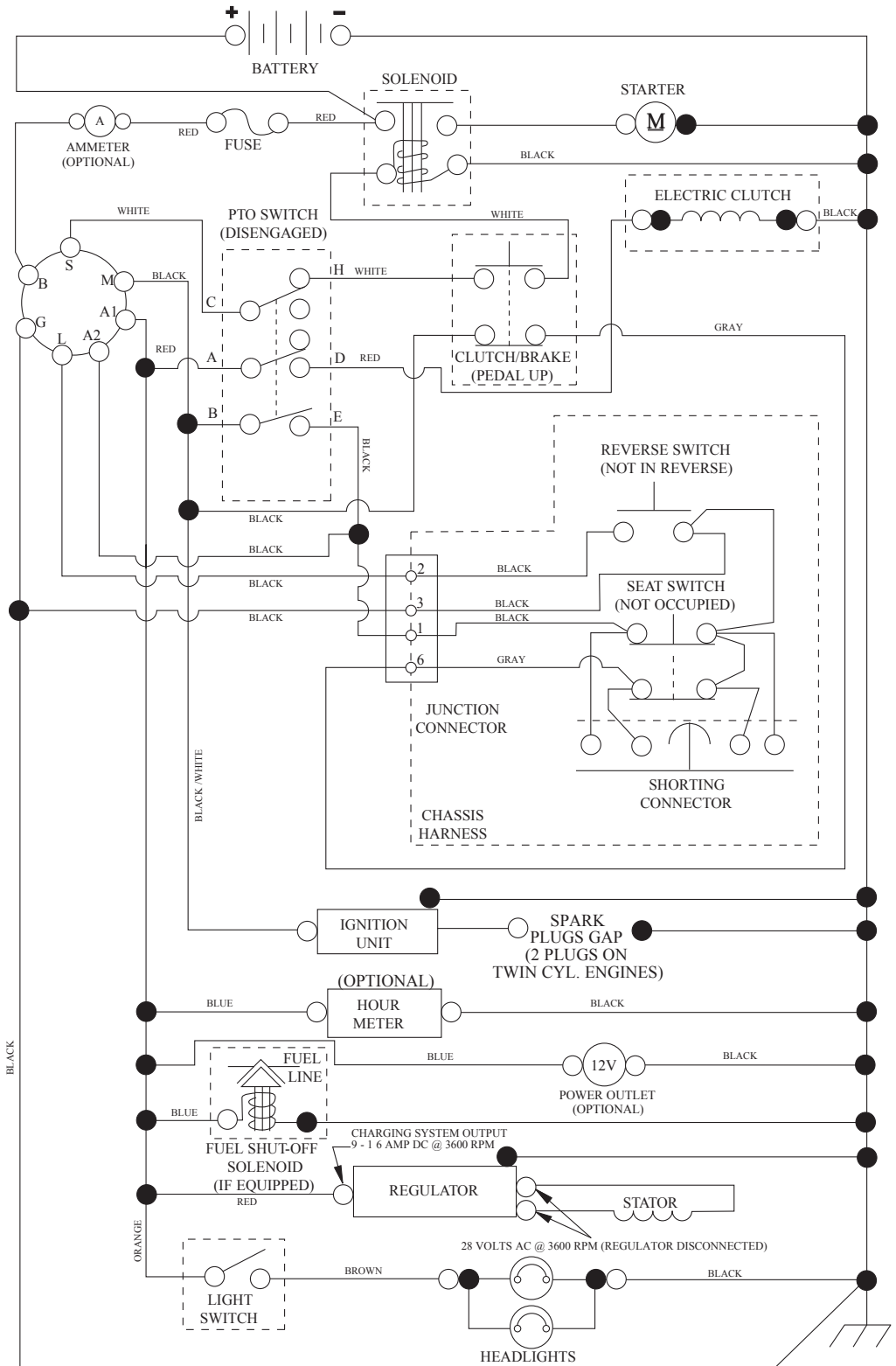

PTO SWITCH (MATING SIDE)

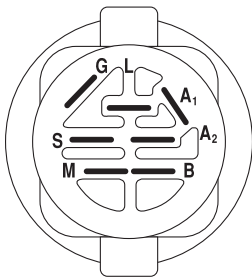

POSITION	CIRCUIT	"MAKE"
OFF	M+G+A1	
RUN/OVERRIDE	B+A1	
RUN	B+A1	L+A2
START	B+S+A1	

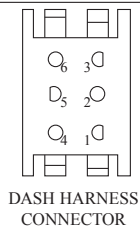
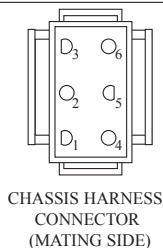

WIRING INSULATED CLIPS  
NOTE: IF WIRING INSULATED CLIPS WERE REMOVED FOR SERVICING OF UNIT, THEY SHOULD BE RE-INSTALLED TO PROPERLY SECURE YOUR WIRING.

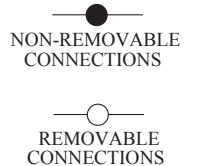

TRACTOR - - MODEL NO. YTH2242TDRF (96041023704), PRODUCT NO. 960 41 02-37  
 ELECTRICAL **32**

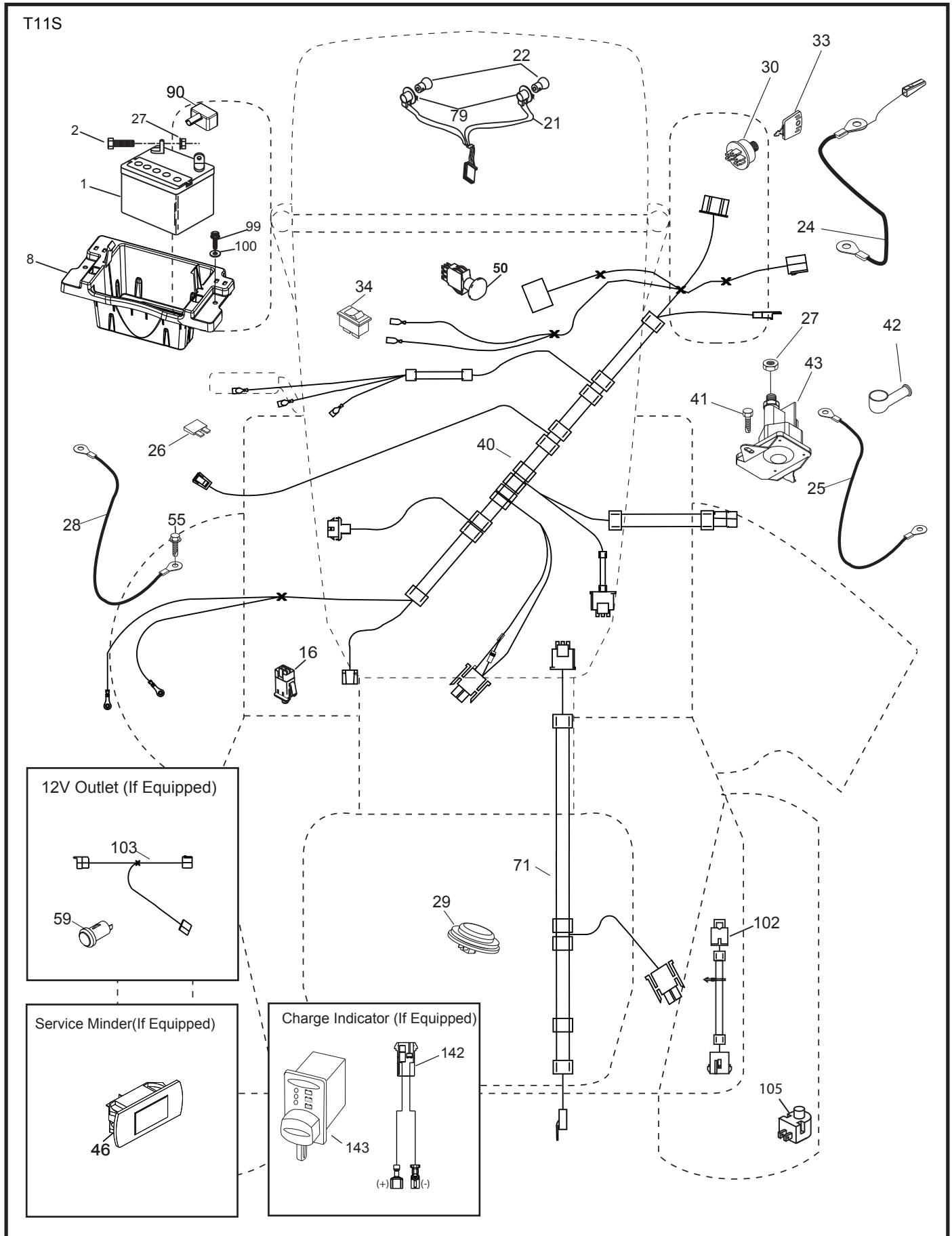

**TRACTOR - - MODEL NO. YTH2242TDRF (96041023704), PRODUCT NO. 960 41 02-37  
ELECTRICAL 32**

<b>KEY NO.</b>	<b>PART NO.</b>	<b>DESCRIPTION</b>
1	532 16 34-65	Battery
2	874 76 04-12	Bolt Hex Head 1/4-20 x 3/4
8	587 20 51-01	Box Battery
16	532 17 61-38	Switch Interlock Push-In
21	532 40 02-52	Harness Socket Light w/4152J
22	532 00 41-52	Bulb Light
24	585 55 56-01	Cable Battery 8"
25	585 55 55-01	Cable Starter
26	532 17 51-58	Fuse
27	873 51 04-00	Nut Keps Hex 1/4-20 unc
28	532 41 65-88	Cable, Ground
29	532 40 15-45	Switch, Seat
30	532 19 33-50	Switch, Ign
33	532 41 19-33	Key/Chain
34	532 11 07-12	Switch Light / Reset
40	581 02 27-01	Harness Ign. Dash
41	817 72 04-08	Screw Thd Cut 1/4-20 x 1/2
42	532 13 15-63	Cover, Terminal
43	532 19 25-07	Solenoid
46	586 16 18-01	Gauge Hrmtr
50	532 17 46-51	Switch PTO
55	817 06 05-12	Screw Thdrol 5/16-18 x 3/4 TYTT
59	532 40 03-03	Outlet 12-Volt
71	532 19 42-76	Harness Ign.
79	532 17 52-42	Socket Asm Bulb Twistlock
90	532 43 53-95	Cover Terminal
99	817 67 04-12	Screw Hexwsh Thdrol 1/4-20 x 3/4
100	819 09 14-16	Washer 9/32 x 7/8 x 16 Ga.
102	532 40 44-54	Harness Pigtail
103	532 40 79-62	Harness 12-Volt Pigtail
105	532 40 75-68	Switch Reverse TT Pedal Control
142	583 85 78-01	Charge Port. Pigtail
143	532 44 80-59	Charge Port

**NOTE:** All component dimensions given in U.S. inches  
1 inch = 25.4 mm

TRACTOR - - MODEL NO. YTH2242TDRF (96041023704), PRODUCT NO. 960 41 02-37  
CHASSIS AND ENCLOSURES **39**

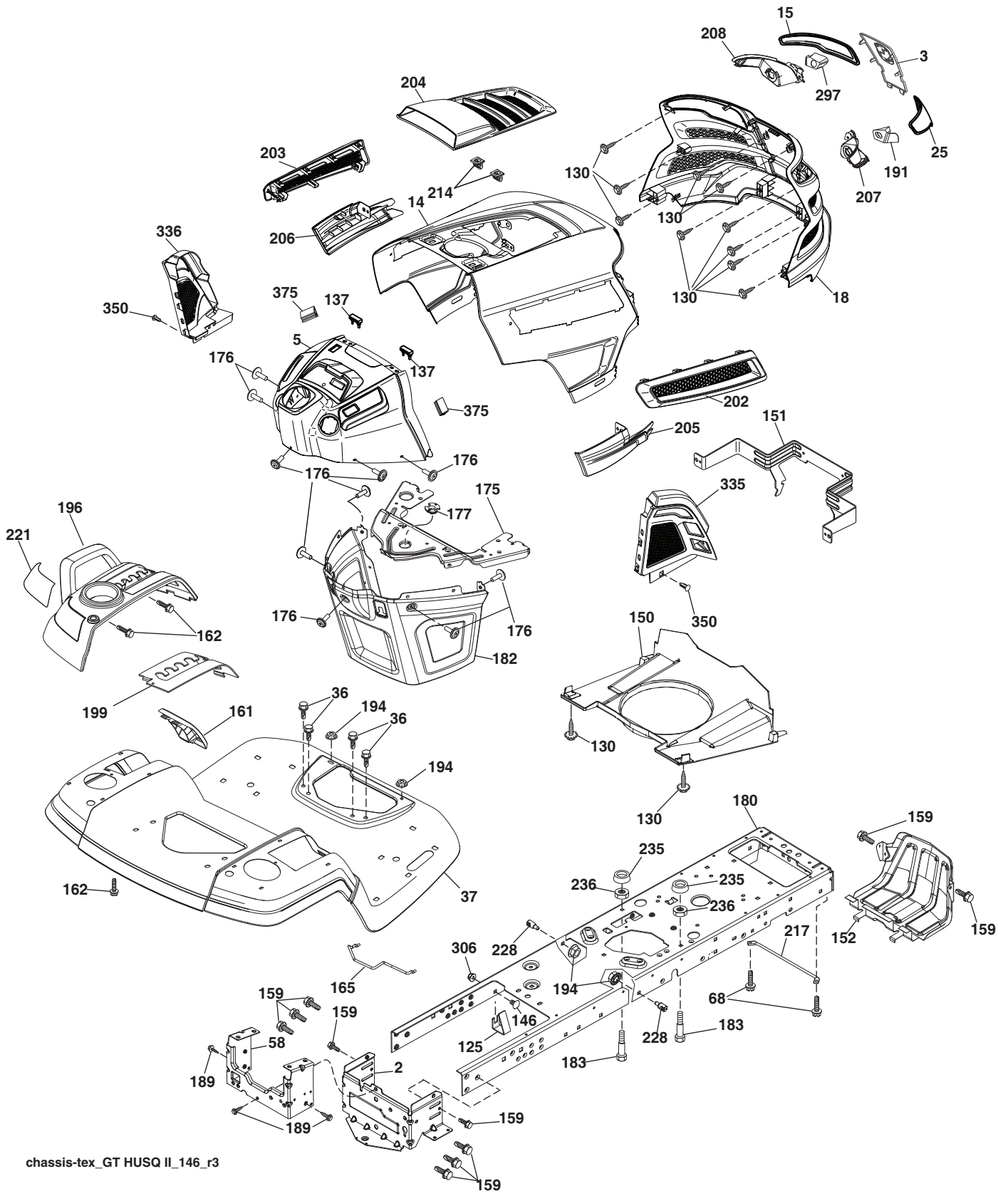

chassis-tex\_GT HUSQ II\_146\_r3

**TRACTOR - - MODEL NO. YTH2242TDRF (96041023704), PRODUCT NO. 960 41 02-37  
CHASSIS AND ENCLOSURES 39**

KEY NO.	PART NO.	DESCRIPTION	KEY NO.	PART NO.	DESCRIPTION
2	532 41 22-82	Drawbar Lower	191	532 43 74-55	Insert Reflective RH
3	532 44 44-81	Applique	194	873 90 05-00	Nut Lock Hex Flange 5/16-18
5	532 43 74-86	Dash	196	532 43 96-74	Console Asm. Deck Lift
14	532 44 11-77	Hood	199	532 19 82-59	Plate Deck Lift
15	532 43 97-33	Lens LH	202	532 43 97-28	Vent Side Hood RH
18	532 44 06-53	Grille	203	532 43 97-27	Vent Side Hood LH
25	532 44 33-85	Lens RH	204	532 43 57-14	Vent Top Hood
36	817 06 05-12	Screw 5/16-18 x 3/4	205	532 43 97-30	Trim Hood Side RH
37	532 44 12-08	Fender	206	532 43 97-29	Trim Hood Side LH
58	532 41 22-81	Drawbar Upper	207	532 43 97-34	Bezel RH
68	817 49 05-08	Screw Thdrol 5/16-18 x 1/2	208	532 43 97-35	Bezel LH
125	581 68 48-01	Clip Fuel Line	214	532 19 91-45	Clip Retainer Tinner
130	532 41 63-58	Screw 10 x .750 BOS Thread	217	532 40 91-67	Rod Pivot
137	532 40 75-90	Bumper Dash	221	532 19 89-09	Reflector LH
146	581 85 79-01	Bolt	228	532 19 51-61	Stud Fastner
150	532 43 97-74	Air Duct	235	532 40 61-29	Spacer Fender
151	532 43 66-70	Bracket Pivot Hood	236	873 93 05-00	Nut Lock 5/16-18 unc
152	532 43 98-70	Shield Browning	297	532 43 74-56	Insert Reflective LH
159	817 00 06-12	Screw 3/8-16 x 3/4	306	873 90 06-00	Nut Lock
161	532 43 99-29	Window, Fuel	335	532 44 82-04	Cover RH Lower Close Out
162	532 14 24-32	Screw Hex Wsh 1/4 x 1/2 unc	336	532 44 53-09	Cover LH Lower Close Out
165	532 19 43-30	Support Tank Rear	350	532 44 51-43	Clip X-mas Tree
175	532 19 63-04	Crossmember	375	586 90 82-01	Dash Clip-On Bumper
176	532 40 07-76	Screw 10-24 x 5/8	--	532 43 18-82	Kit Guard Brush
177	532 19 52-28	Bushing Steering			
180	532 44 55-59	Chassis			
182	532 40 68-59	Dash Lower			
183	874 52 05-20	Bolt 5/16-18 x1-1/4			
189	817 00 05-12	Screw 5/16-18 x 3/4			

**NOTE:** All component dimensions given in U.S. inches  
1 inch = 25.4 mm

TRACTOR - - MODEL NO. YTH2242TDRF (96041023704), PRODUCT NO. 960 41 02-37  
 DRIVE **40**

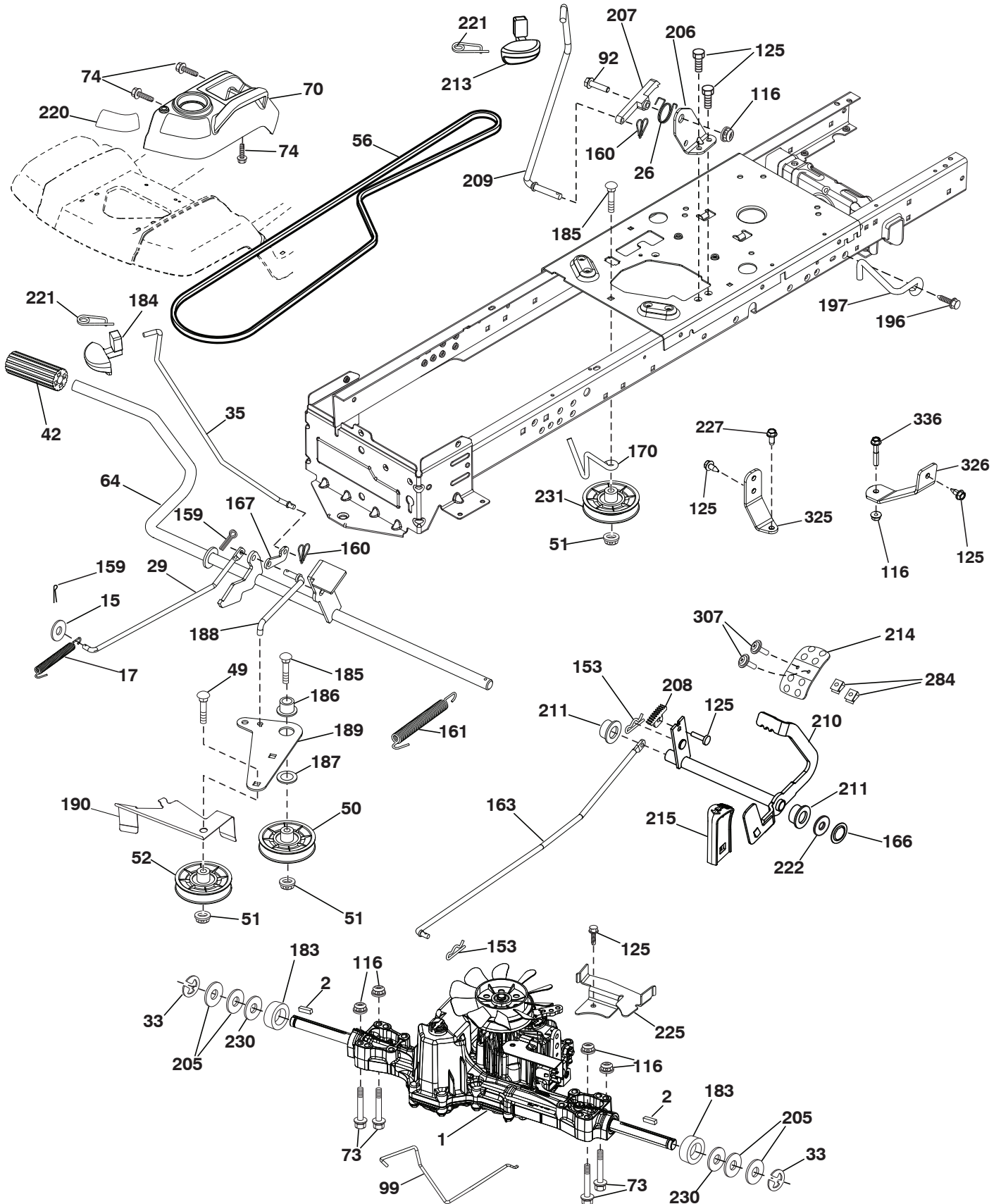

drive-tex\_K46\_pedal\_160



**TRACTOR - - MODEL NO. YTH2242TDRF (96041023704), PRODUCT NO. 960 41 02-37  
DRIVE **40****

KEY NO.	PART NO.	DESCRIPTION	KEY NO.	PART NO.	DESCRIPTION
1	---	Transaxle, TUFFTORQ K46CR (501051401) (Order parts from transaxle manufacturer.)	186	532 19 43-21	Spacer Retainer
2	532 12 35-83	Key	187	819 13 32-10	Washer
15	819 13 13-16	Washer 13/32 x 13/16 x 16 Ga.	188	582 21 70-01	Link Clutch Ground Drive, Long
17	532 41 36-78	Spring, Brake	189	532 19 43-17	Bellcrank Ground Drive
26	532 19 96-79	Spring Return Cruise	190	532 19 43-18	Keeper Bellcrank Ground Drive
29	532 40 38-06	Rod, Brake	196	817 00 06-16	Screw 3/8-16 x 1
33	812 00 00-01	Ring E	197	585 65 86-01	Bracket Clutch Anti-Rotation
35	583 86 45-01	Rod, Brake, Park	205	532 12 17-48	Washer
42	532 12 48-72	Cover, Foot Pedal	206	532 44 85-96	Bracket Mount Latch Cruise
49	872 11 06-14	Bolt	207	532 19 78-68	Latch Control Cruise
50	532 19 43-27	Pulley Idler Flat	208	532 19 78-69	Gear Sector Control Cruise
51	873 90 06-00	Lock Nut 3/8-16	209	532 19 95-92	Rod Control Cruise
52	532 19 43-26	Idler V-Groove	210	532 19 78-60	Rocker Asm. Pedal Control
56	532 13 09-69	V-Belt, Drive	211	532 12 01-83	Bearing Nylon
64	532 19 78-65	Shaft Asm. Pedal Brake Control	213	532 40 31-19	Knob Control Cruise
70	532 43 96-61	Console Shift	214	532 41 68-63	Pedal Forward
73	874 49 05-40	Bolt Hex Flghd 5/16-18 x 2-1/2 Gr. 5	215	532 40 17-23	Pedal Reverse
74	532 14 24-32	Screw Hex Wsh. Hi-Lo 1/4 x 1/2 unc	220	532 19 89-08	Reflector RH
92	874 76 05-20	Bolt Fin Hex 5/16-18 unc x 1.25	221	532 40 31-87	Retainer Spring Clip Handle
99	532 41 57-42	Rod Spring Bypass	222	879 21 20-10	Washer 21/32 x 1-1/4 x 10 Ga.
116	873 90 05-00	Nut Lock Hex Flange 5/16-18	225	532 40 33-19	Keeper Belt Trans.
125	817 00 05-12	Screw 5/16-18 x 3/4	227	817 49 05-12	Screw Thdrol 5/16-18 x 3/4
153	532 12 47-88	Retainer Spring	230	532 18 89-67	Washer Hardened
159	876 02 04-12	Pin Cotter 1/8 x 3/4	231	532 40 72-87	Idler V-Groove
160	532 16 94-84	Retainer Clip	284	532 41 76-93	Nut U-CHNL 1/4-20 550DP .350 PNL
161	532 10 57-09	Spring, Return, Clutch	307	874 18 04-12	Screw PHD 1/4-20 Box Drive
163	532 44 82-75	Rod Pedal Control	325	586 43 12-02	Torque Strap K46 LT RH
166	532 42 91-64	Nut Push	326	586 00 11-02	Bracket Trq Stp 46 20" Tire RH
167	532 40 52-57	Latch Brake Parking	336	587 25 96-01	Bolt 5/16-18 x 1-3/4 Flanged
170	532 41 34-30	Keeper Belt Centerspan			
183	532 13 70-57	Spacer Split			
184	532 44 14-55	Handle Parking Brake			
185	872 11 06-22	Bolt Rdhd Sqnk 3/8-16 x 2-1/2			

**NOTE:** All component dimensions given in U.S. inches  
1 inch = 25.4 mm



**TRACTOR - - MODEL NO. YTH2242TDRF (96041023704), PRODUCT NO. 960 41 02-37  
ENGINE 24**

KEY NO.	PART NO.	DESCRIPTION
1	-----	Engine Briggs Model No. 40R877-0022-G1 (587251601) (Order parts from engine manufacturer.)
2	532 44 59-62	Muffler
9	584 90 80-01	Keeper Belt Engine
11	587 24 16-01	Clutch Electric
12	532 40 50-97	Pulley Engine
15	532 42 28-04	Tank Fuel
18	584 24 87-02	Cap
20	586 21 96-01	Control Throttle/Choke
21	532 41 63-58	Screw #10 x .750 BOS Thread
28	532 14 21-58	Fuel Line
29	532 13 71-80	Spark Arrester Kit
37	532 12 34-87	Clamp Hose
41	532 12 61-97	Washer 1-1/2 OD x 15/32 ID x .250
42	810 04 07-00	Washer Lock 7/16
45	873 51 04-00	Nut Keps Hex 1/4-20 unc
62	532 43 40-17	Heat Shield
69	532 16 53-91	Gasket
70	581 88 11-01	Tube Exhaust
71	581 88 10-01	Exhaust Tube
79	532 18 39-06	Screw Socket HP 5/16-18 x 1
81	532 14 84-56	Tube Drain Oil Easy
82	532 42 82-87	Valve Oil Drain
84	817 06 06-20	Screw 3/8-16 x 1-1/4
85	532 17 99-53	Bolt Hex 7/16-20 x 3.75 Gr
90	817 00 06-16	Screw 3/8-16 x 1
91	532 18 74-95	Bushing 1.375 OD
102	817 00 05-12	Screw 5/16-18 x 3/4
116	539 13 26-24	Knob
117	532 42 08-28	Valve Fuel Reserve

**NOTE:** All component dimensions given in U.S. inches  
1 inch = 25.4 mm

**Engine Power Rating Information**

The gross power rating for individual gas engine models is labeled in accordance with SAE (Society of Automotive Engineers) code J1940 (Small Engine Power & Torque Rating Procedure), and rating performance has been obtained and corrected in accordance with SAE J1995 (Revision 2002-05). Torque values are derived at 3060 RPM; horsepower values are derived at 3600 RPM. Actual gross engine power will be lower and is affected by, among other things, ambient operating conditions and engine-to-engine variability. Given both the wide array of products on which engines are placed and the variety of environmental issues applicable to operating the equipment, the gas engine will not develop the rated gross power when used in a given piece of power equipment (actual “on-site” or net power). This difference is due to a variety of factors including, but not limited to, accessories (air cleaner, exhaust, charging, cooling, carburetor, fuel pump, etc.), application limitations, ambient operating conditions (temperature, humidity, altitude), and engine-to-engine variability. Due to manufacturing and capacity limitations, Briggs & Stratton may substitute an engine of higher rated power for this Series engine.

TRACTOR - - MODEL NO. YTH2242TDRF (96041023704), PRODUCT NO. 960 41 02-37  
STEERING ASSEMBLY **41**

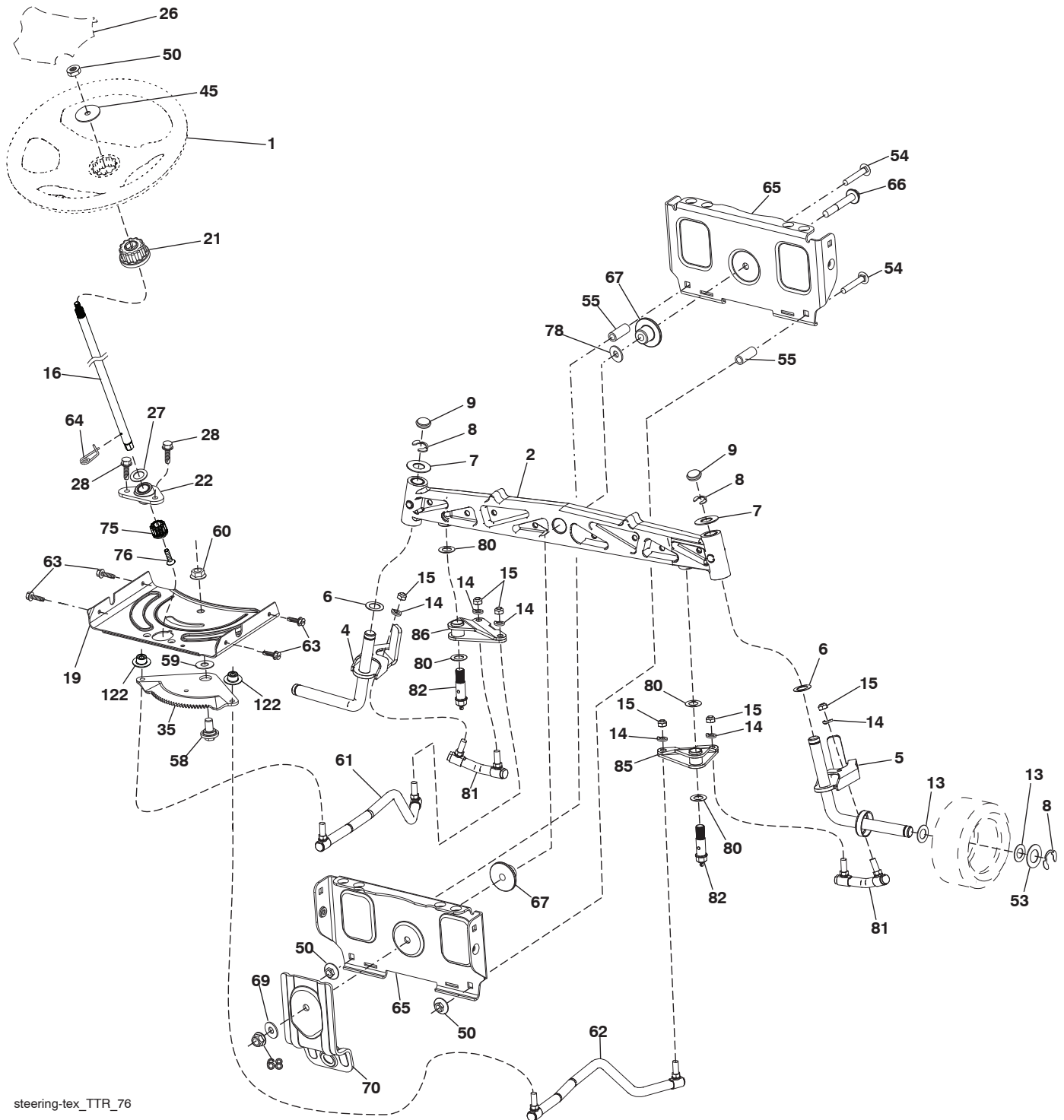

steering-tex\_TTR\_76

**TRACTOR - - MODEL NO. YTH2242TDRF (96041023704), PRODUCT NO. 960 41 02-37  
STEERING ASSEMBLY 41**

<b>KEY NO.</b>	<b>PART NO.</b>	<b>DESCRIPTION</b>
1	532 43 97-40	Wheel, Steering
2	532 43 68-70	Axle Asm., Front
4	532 43 68-73	Spindle Asm., LH
5	532 43 68-74	Spindle Asm., RH
6	532 12 49-31	Bearing, Race Thrust Harden
7	532 12 17-48	Washer 25/32 x 1-5/8 x 16 Ga.
8	812 00 00-29	Ring, Clip #T5304-75
9	532 12 12-32	Cap, Spindle
13	532 12 17-49	Washer 25/32 x 1-1/4 x 16 Ga.
14	810 04 06-00	Washer, Lock Hvy Hlcl Spr 3/8
15	873 54 06-00	Nut, Crown Lock 3/8-24 unf
16	587 01 60-02	Shaft Steering
19	532 19 47-29	Plate Steering
21	586 84 02-01	Adapter, Wheel Steering Splnd Alum
22	585 02 99-01	Bearing Subasm Shaft Steer Low
26	532 43 97-43	Insert, Wheel Steering
27	819 21 16-16	Washer 21/32 x 1 x 16 Ga.
28	817 00 06-12	Screw 3/8-16 x 3/4
35	532 44 07-70	Gear, Sector Plate
45	587 01 64-01	Washer 3/8 ID 2-3/8OD 12 Ga. PLTD
50	873 90 06-00	Nut Lock Flg. 3/8-16 unc
53	532 18 89-67	Washer Hardened .793 x 1.637 x .060
54	874 76 06-36	Bolt Hex 3/8-16 unc x 2-1/4
55	532 41 47-36	Spacer Brace Axle
58	532 19 47-47	Bolt Shoulder Sector Pivot CFM
59	532 19 47-48	Washer Thrust Sector Steering
60	873 97 10-00	Nut Flange Lock 5/8-11
61	532 43 68-84	Draglink, LH
62	532 43 68-85	Draglink, RH
63	817 00 05-12	Screw 5/16-18 x 3/4
64	532 19 98-49	Retainer Clip Spring Steering
65	532 19 47-34	Brace Axle Front
66	871 02 07-48	Bolt Hex Fghd 7/16-14 x 3 Serr
67	532 19 47-37	Bushing PM Front Axle
68	873 90 07-00	Nut Lock Flange 7/16-14 Gr. 5
69	532 19 91-62	Washer 1.5 x .505 x .118
70	585 33 88-01	Bracket Deck Susp. Front
75	580 68 37-01	Pinion
76	580 68 36-01	Screw Head Sock
78	532 05 70-79	Washer Thrust
80	532 00 13-70	Washer Thrust 5/8 x 1.10 x 1/32
81	532 43 68-87	Link Cross RH
82	532 44 21-47	Pivot Bolt
85	532 44 18-73	Pivot RH
86	532 44 18-72	Pivot LH
122	532 44 49-62	Cap Gear Sector

**NOTE:** All component dimensions given in U.S. inches  
1 inch = 25.4 mm



**TRACTOR - - MODEL NO. YTH2242TDRF (96041023704), PRODUCT NO. 960 41 02-37  
MOWER DECK 44**

KEY NO.	PART NO.	DESCRIPTION	KEY NO.	PART NO.	DESCRIPTION
1	574 77 89-02	Deck	33	539 13 20-19	Nut, 7/16-14 Hex Nyloc
2	539 11 21-70	Housing Assembly	34	521 99 65-01	Nut 3/8-16 Hex Flg Nyloc
3	532 18 76-90	Washer-Spacer	35	575 22 47-02	Shield, Belt LH
5	532 40 02-34	Nut, 9/16 Top Center Lock	36	575 96 71-02	Shield, Belt RH
6	539 11 20-78	Blade, 14-5/8"	37	539 99 02-09	Hcs 5/16-18 x 1 Gr. 5
7	532 19 30-03	Bolt, 7/16, Assy Blade	38	539 99 01-87	Wash 5/16 Slw
8	532 17 60-66	Roller, Nose	40	532 13 39-57	Wheel, Gauge
9	532 17 91-27	Rod, Roller, Nose	41	532 19 34-06	Bolt, Shoulder
10	532 19 42-08	Clip Retainer	42	532 19 51-85	Arm, Susp., Rear
11	539 11 07-31	Discharge Chute - 42" Plastic	43	539 20 02-82	Nut, 3/8-16 Hex Jam Nyloc
12	539 11 07-35	Spring - Torsion	44	539 11 36-21	Sb 3/8-16 x 3/8 Skt Hd
13	539 11 07-36	Pin, Clevis 5/16 x 5.19	45	539 99 01-22	Washer, 3/8 Sae Flt
14	532 19 51-61	Stud, Fasten w/ Anti- Rotate	46	574 84 56-01	Belt, 42" Fab Deck
15	539 11 24-12	Confinement Plate	50	575 22 43-01	Guard, Belt
16	539 99 07-99	Rhsnb 5/16-18 x 5/8 Gr. 5	51	575 22 44-01	Pulley, Mandrel
17	539 99 07-17	Nut 5/16-18 Hex Nyloc	52	539 10 48-70	Hcs 7/16-14 x 2-1/2 Gr. 5
18	575 22 45-01	Idler Bushing	53	532 41 55-98	Washout Port
19	539 13 27-28	Pulley, Idler	54	539 10 84-61	Bolt, 1/4-20 x 1/2
20	539 10 82-71	Hcs 3/8-16 x 3-1/2 Gr. 5	55	539 11 55-74	Eyebolt 5/16 x 3-1/2
21	539 10 65-04	Heavy Washer	56	539 10 68-50	Spring
22	539 99 05-17	Washer, 3/8 Flat Std	58	532 11 04-85	Ball Bearing
23	539 97 69-79	Nut 3/8-16 Hex Nyloc	59	575 41 62-01	Pulley
24	539 11 28-99	Nut 5/16-18 Hex Flange Nyloc	60	532 16 94-84	Retainer Clip
25	539 10 48-64	Washer, 7/16 Flat	61	584 95 39-01	Bolt Hex Wsh Hd .313-18 x 1.19
26	532 17 85-15	Washer, Flat Hardened	--	532 44 53-57	Mower Deck Complete
27	532 19 61-04	Pulley, Idler Spec. Hub			
28	574 82 71-01	Arm, Idler, Blk			
29	539 99 09-23	Rhsnb 3/8-16 x 1-3/4 Gr. 5			
30	532 17 79-68	Pulley, Idler			
31	539 10 47-63	Retainer 5/16c U Type			
32	539 99 06-92	Washer, 5/16 Std Flt			

**NOTE:** All component dimensions given in U.S. inches  
1 inch = 25.4 mm



**TRACTOR - - MODEL NO. YTH2242TDRF (96041023704), PRODUCT NO. 960 41 02-37**  
**MOWER LIFT 45**

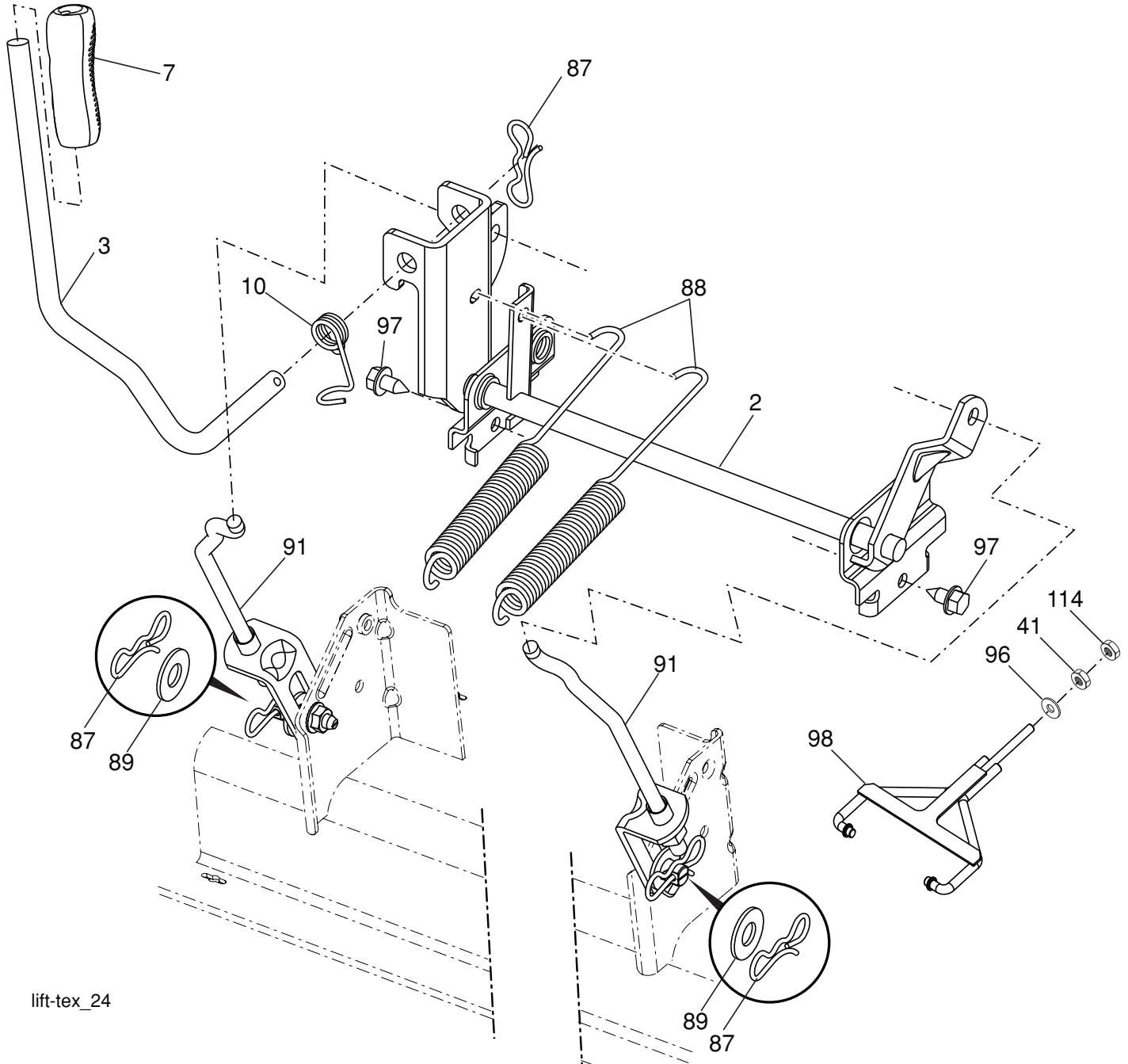

lift-tex\_24

KEY PART NO.	PART NO.	DESCRIPTION
2	532 42 20-27	Shaft Asm., Lift
3	532 19 52-30	Lever Asm., Lift RH
7	580 96 23-01	Grip, Lever
10	532 19 63-14	Spring Torsion
41	532 17 59-94	Nut, Lift Link
87	532 19 42-09	Pin Cotter 7/16 Bow Tie Lock
88	532 41 07-10	Spring Lift Assist
89	819 19 19-12	Washer Clear Zinc

KEY PART NO.	PART NO.	DESCRIPTION
91	532 40 34-07	Link Lift Susp Mower Rear
96	532 19 52-63	Bushing, Spherical
97	817 00 06-12	Screw 3/8-16 x .75
98	574 82 25-01	Link Lift Susp. Front Mower
114	873 36 07-00	Nut Jam 7/16-20

**NOTE:** All component dimensions given in U.S. inches  
 1 inch = 25.4 mm



**TRACTOR - - MODEL NO. YTH2242TDRF (96041023704), PRODUCT NO. 960 41 02-37  
SEAT ASSEMBLY 42**

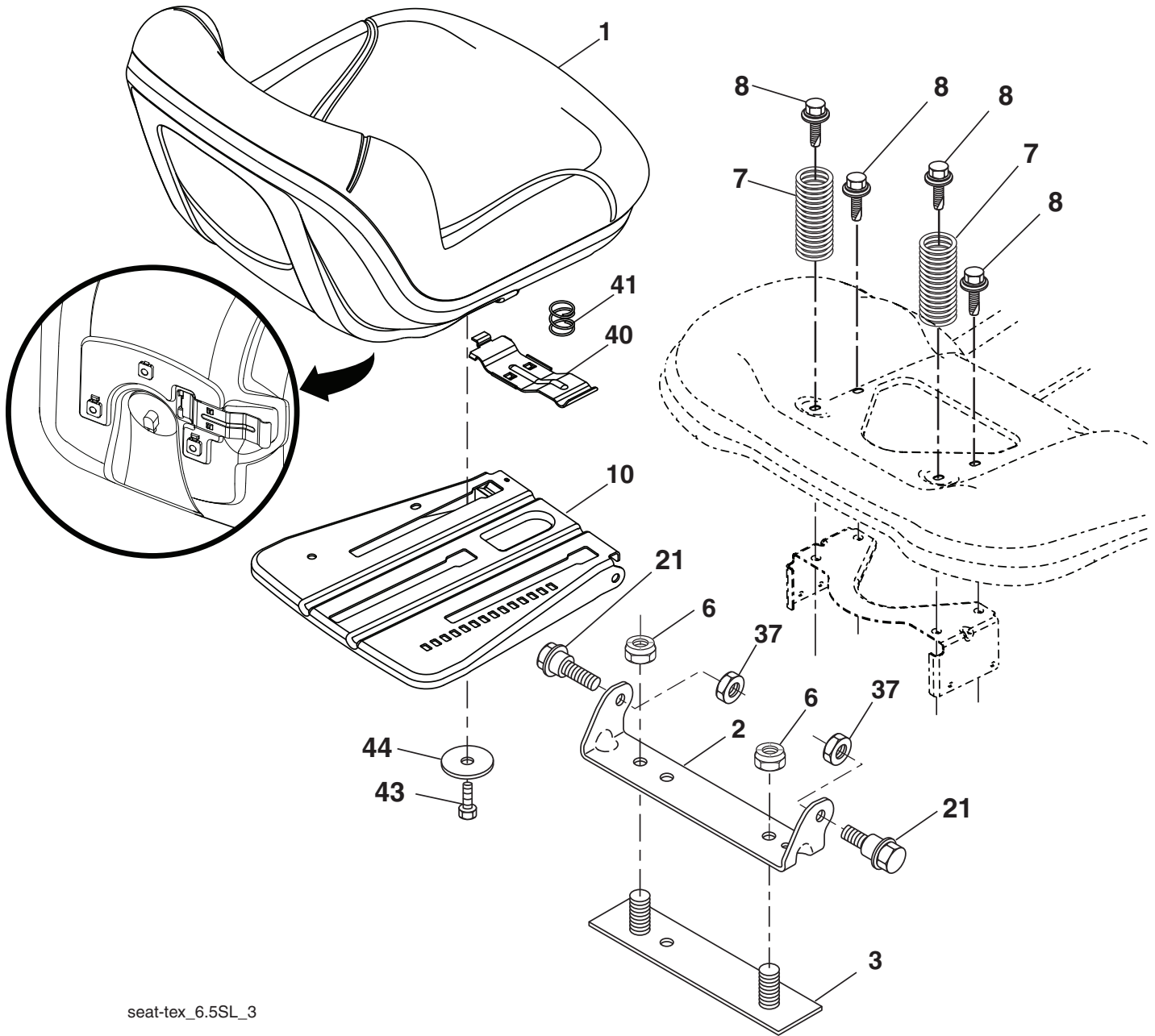

seat-tex\_6.5SL\_3

KEY NO.	PART NO.	DESCRIPTION
1	532 43 98-22	Seat
2	532 18 01-66	Bracket Pivot Fender
3	532 14 06-75	Strap, Asm Fender
6	873 80 06-00	Nut, Lock w/Ins. 3/8-16 unc
7	532 12 41-81	Spring, Seat Cprsn
8	532 17 18-77	Bolt 5/16-18 unc x 3/4 w/Sems
10	532 19 69-77	Pan, Seat
21	532 17 18-52	Bolt, Shoulder 5/16-18

KEY NO.	PART NO.	DESCRIPTION
37	873 80 05-00	Nut, Lock 5/16-18 unc
40	532 19 76-61	Handle Slide Seat
41	532 19 82-00	Spring Latch Seat
43	874 76 06-12	Bolt Fin Hex 3/8-16 unc x 3/4
44	819 13 38-12	Washer 13/32 x 2-3/8 x 12 Ga.

**NOTE:** All component dimensions given in U.S. inches  
1 inch = 25.4 mm

