

**ILLUSTRATED PARTS LIST**

**MODEL NUMBER 12527HVX**

**PRODUCT NUMBER 961 95 00-18**

**MFG. ID. NUMBER 96195001800**

# REPAIR PARTS

# AUGER HOUSING / IMPELLER ASSEMBLY

SNOW THROWER - MODEL NO. 12527HVX (96195001800), PRODUCT NO. 961 95 00-18

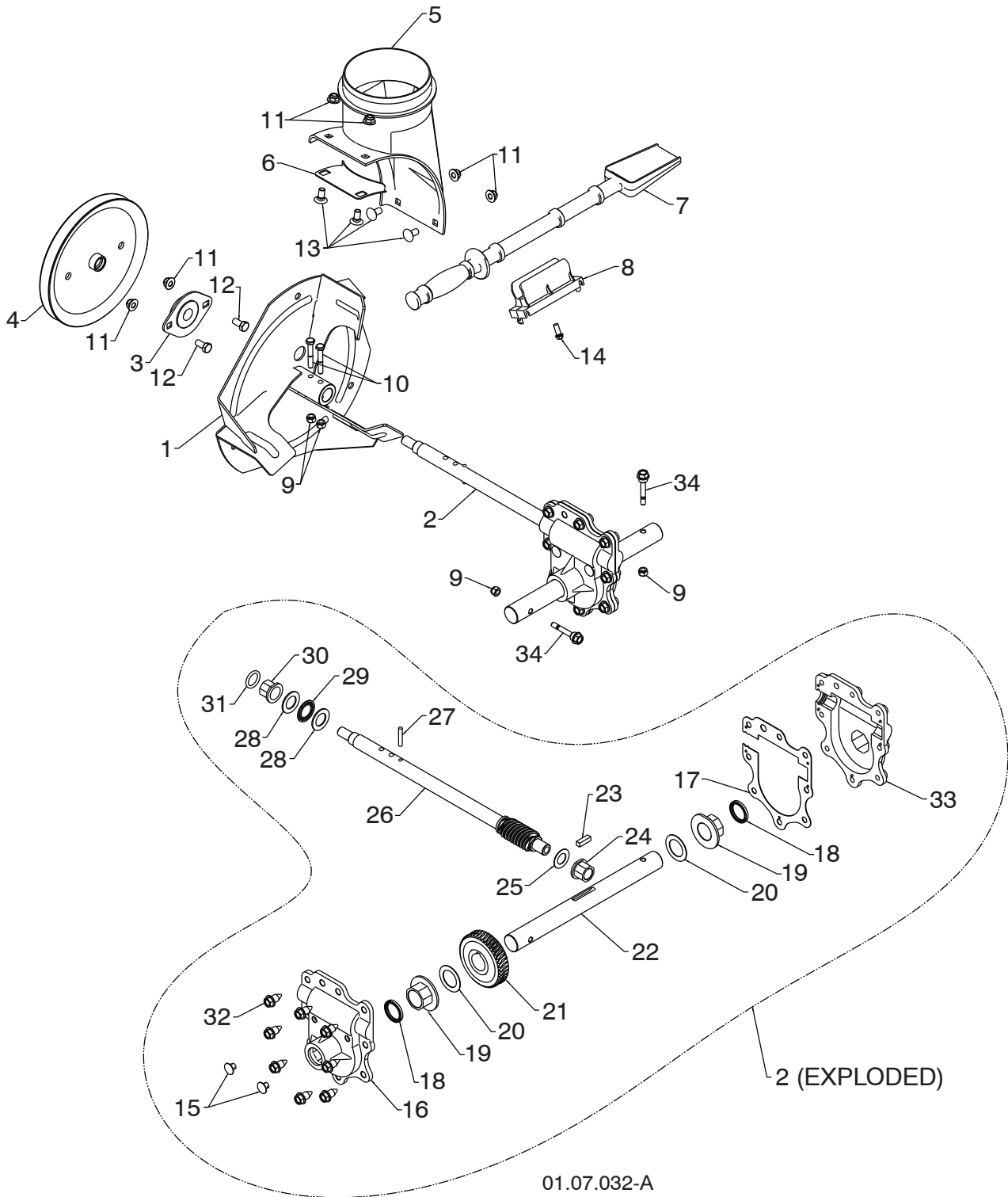

**NOTE:** All component dimensions given in U.S. inches. 1 inch = 25.4 mm  
**IMPORTANT:** Use only Original Equipment Manufacturer (O.E.M.) replacement parts.  
Failure to do so could be hazardous, damage your snow thrower and void your warranty.

## REPAIR PARTS

## AUGER HOUSING / IMPELLER ASSEMBLY

SNOW THROWER - MODEL NO. **12527HVX** (96195001800), PRODUCT NO. 961 95 00-18

KEY NO.	PART NO.	DESCRIPTION
1	532 18 41-05	IMPELLER
2	584 64 83-01	GEARBOX ASSEMBLY
3	532 18 89-09	BEARING
4	585 09 32-01	IMPELLER PULLEY
5	532 44 24-38	DISCHARGE BASE
6	532 17 86-75	CORNER BRACKET
7	532 19 21-99	CLEAN OUT TOOL
8	532 40 54-00	TOOL CLIP
9	873 80 04-00	NUT 1/4-20
10	874 78 04-26	SCREW 1/4-20 X .625
11	532 42 79-42	NUT 5/16-18
12	532 16 31-83	SCREW 5/16-18 X .625
13	532 18 03-55	CARRIAGE BOLT
14	532 19 41-89	SCREW 13-16 X .625
15	532 40 77-60	PLUG
16	532 42 73-02	GEARBOX COVER RH
17	532 42 73-45	GASKET
18	532 40 77-70	SEAL
19	532 40 77-62	BEARING
20	532 17 46-97	THRUST WASHER 1.00
21	532 40 77-63	WORM GEAR
22	532 40 77-64	AUGER SHAFT
23	532 18 92-82	SQUARE KEY
24	532 40 77-58	BEARING
25	532 17 46-83	THRUST WASHER
26	584 64 84-01	IMPELLER SHAFT
27	532 18 42-05	ROLL PIN
28	532 17 46-81	THRUST WASHER
29	532 17 46-84	THRUST BEARING
30	532 40 77-69	BEARING
31	532 40 77-68	O-RING
32	532 40 77-67	SCREW 5/16-18 X .750
33	532 42 73-17	GEARBOX COVER LH
34	532 19 20-90	SHEAR BOLT

**NOTE:** All component dimensions given in U.S. inches. 1 inch = 25.4 mm

**IMPORTANT:** Use only Original Equipment Manufacturer (O.E.M.) replacement parts. Failure to do so could be hazardous, damage your snow thrower and void your warranty.

# REPAIR PARTS

# AUGER HOUSING / IMPELLER ASSEMBLY

SNOW THROWER - MODEL NO. 12527HVX (96195001800), PRODUCT NO. 961 95 00-18

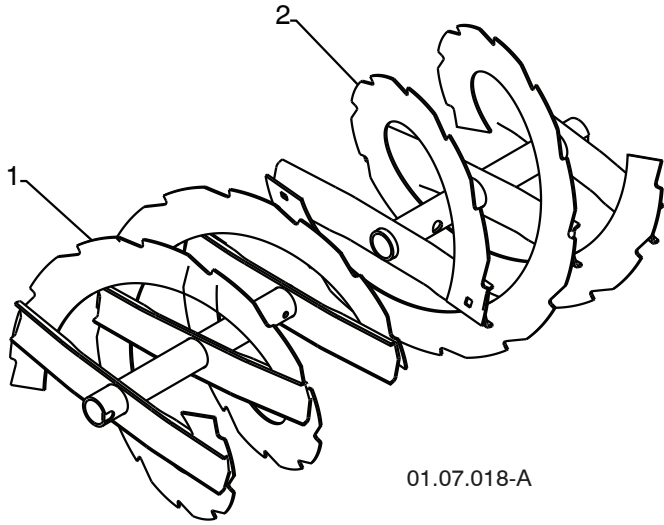

01.07.018-A

KEY NO.	PART NO.	DESCRIPTION
1	532 42 11-35	AUGER 27 LH
2	532 42 11-23	AUGER 27 RH

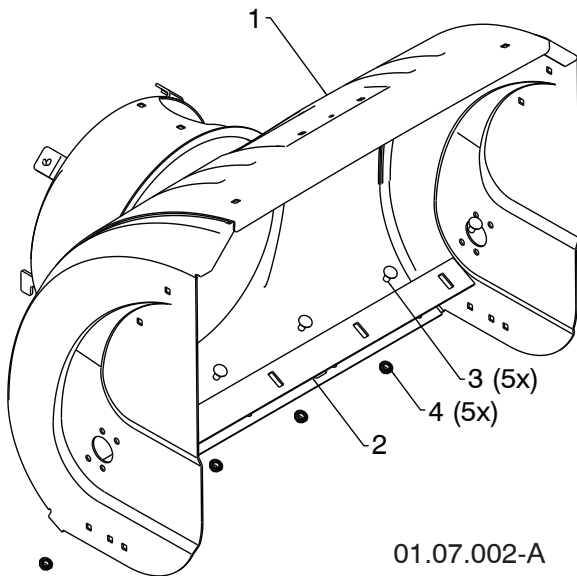

01.07.002-A

KEY NO.	PART NO.	DESCRIPTION
1	532 40 77-39	AUGER HOUSING 27
2	532 41 53-71	SCRAPER BAR
3	872 27 05-05	CARRIAGE BOLT 5/16-18 X .625
4	532 15 53-77	NUT 5/16-18

**NOTE:** All component dimensions given in U.S. inches. 1 inch = 25.4 mm  
**IMPORTANT:** Use only Original Equipment Manufacturer (O.E.M.) replacement parts.  
Failure to do so could be hazardous, damage your snow thrower and void your warranty.

# REPAIR PARTS

# AUGER HOUSING / IMPELLER ASSEMBLY

SNOW THROWER - MODEL NO. 12527HVX (96195001800), PRODUCT NO. 961 95 00-18

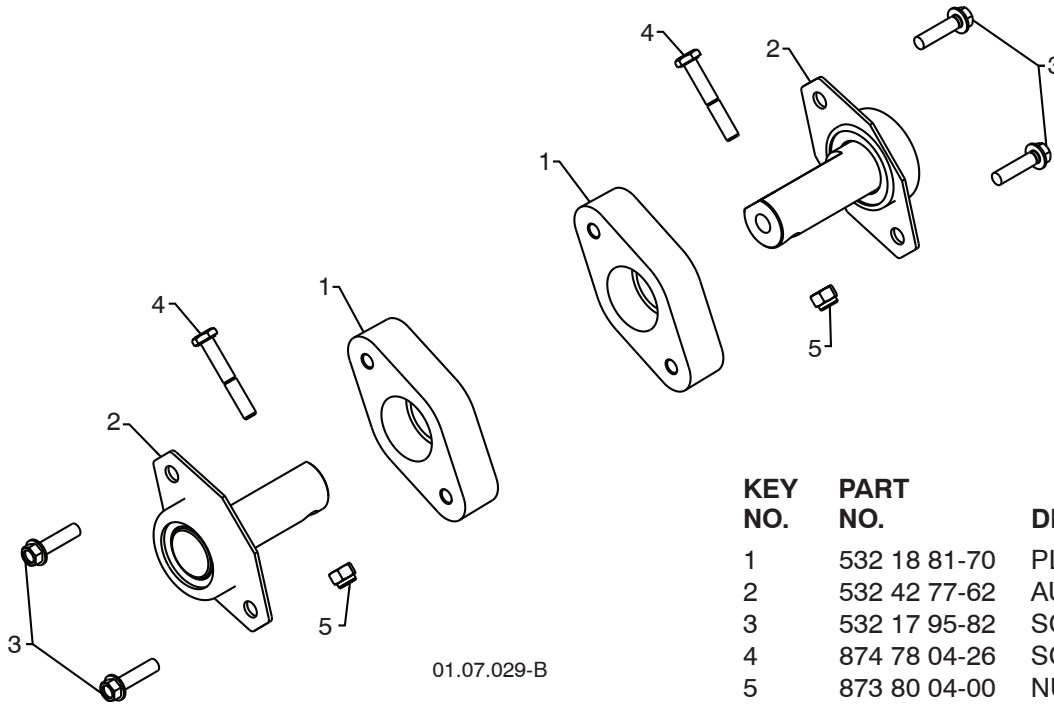

01.07.029-B

KEY NO.	PART NO.	DESCRIPTION
1	532 18 81-70	PLASTIC RETAINER
2	532 42 77-62	AUGER BALL BEARING
3	532 17 95-82	SCREW 5/16-18 X 1.00
4	874 78 04-26	SCREW 1/4-20 X .625
5	873 80 04-00	NUT 1/4-20

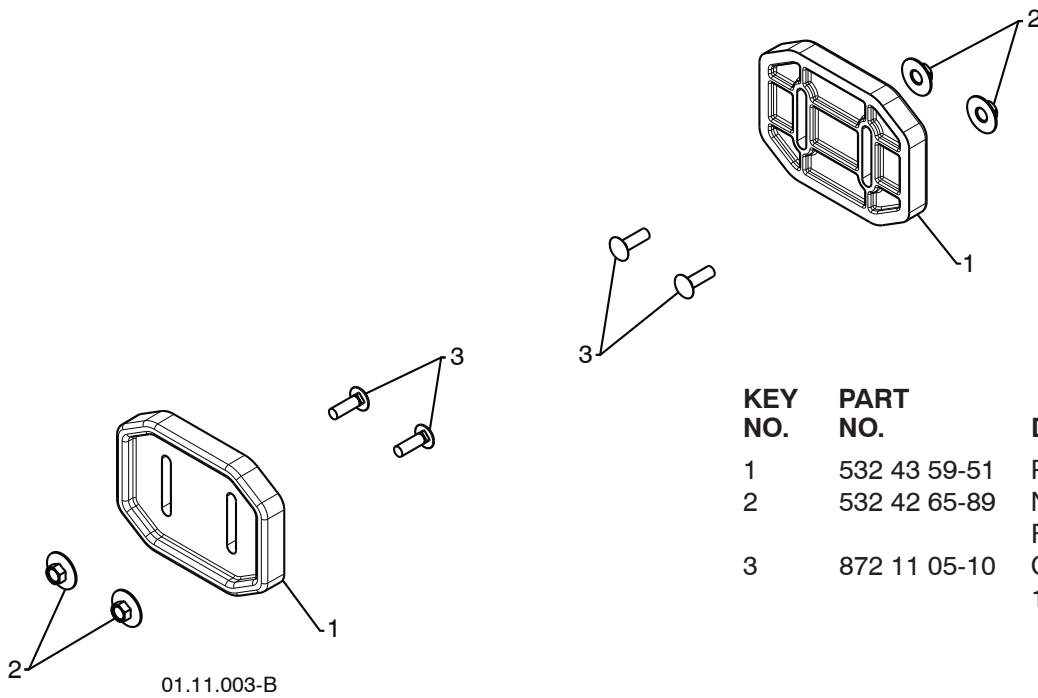

01.11.003-B

KEY NO.	PART NO.	DESCRIPTION
1	532 43 59-51	PLATE SKID PLASTIC HDPE
2	532 42 65-89	NUT 5/16-18 LARGE HEX FLANGE BLK
3	872 11 05-10	CARRIAGE BOLT 5/16-18 X 1.25

**NOTE:** All component dimensions given in U.S. inches. 1 inch = 25.4 mm  
**IMPORTANT:** Use only Original Equipment Manufacturer (O.E.M.) replacement parts. Failure to do so could be hazardous, damage your snow thrower and void your warranty.

# REPAIR PARTS

# CONTROL PANEL / DISCHARGE CHUTE

SNOW THROWER - MODEL NO. **12527HVX** (96195001800), PRODUCT NO. 961 95 00-18

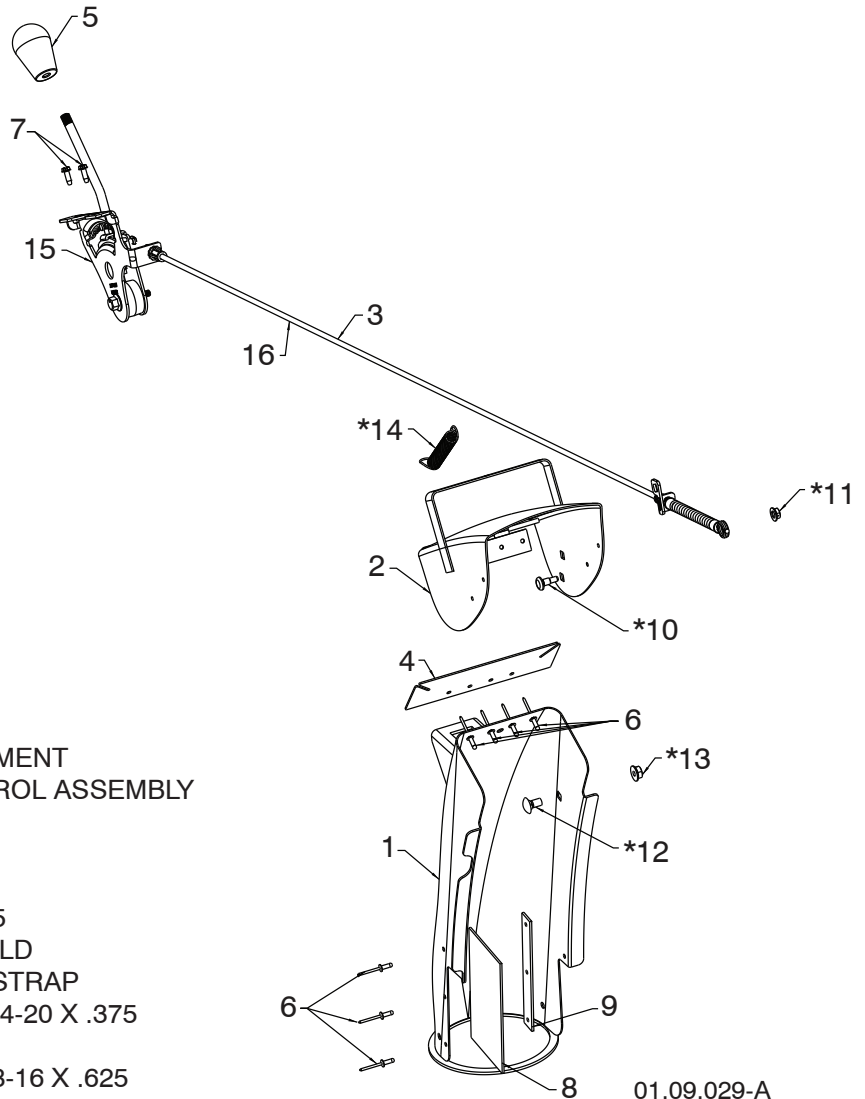

KEY NO.	PART NO.	DESCRIPTION
1	532 44 40-41	CHUTE WELDMENT
2	532 18 41-13	DEFLECTOR WELDMENT
3	585 27 17-01	DEFLECTOR CONTROL ASSEMBLY
4	532 42 03-25	DEFLECTOR SEAL
5	580 67 32-01	KNOB BLACK
6	532 12 84-15	POP RIVET
7	817 54 10-08	SCREW 10-24 X .625
8	532 43 03-24	CHUTE SHOW SHIELD
9	532 42 17-28	SHIELD RETAINER STRAP
*10	532 17 98-29	SHOULDER BOLT 1/4-20 X .375
*11	532 19 17-30	NUT 1/4-20
*12	872 25 05-05	CARRIAGE BOLT 3/8-16 X .625
*13	532 75 11-53	NUT 5/16-18
*14	532 18 45-05	DEFLECTOR SPRING
15	532 42 06-79	(SERVICE PART) DEFLECTOR CONTROL
16	532 42 06-72	(SERVICE PART) DEFLECTOR CABLE BLACK

## NOTE:

1. ALL ITEMS INDICATED WITH AN \* ARE PROVIDED IN THE BAG OF ITEMS SHIPPED LOOSE WITH PRODUCT.
2. ITEMS 15 AND 16 ARE SERVICE PART NUMBERS TO ALLOW PURCHASE OF INDIVIDUAL ITEMS IF NECESSARY.

**NOTE:** All component dimensions given in U.S. inches. 1 inch = 25.4 mm  
**IMPORTANT:** Use only Original Equipment Manufacturer (O.E.M.) replacement parts.  
 Failure to do so could be hazardous, damage your snow thrower and void your warranty.

# REPAIR PARTS

# CONTROL PANEL / DISCHARGE CHUTE

SNOW THROWER - MODEL NO. **12527HVX** (96195001800), PRODUCT NO. 961 95 00-18

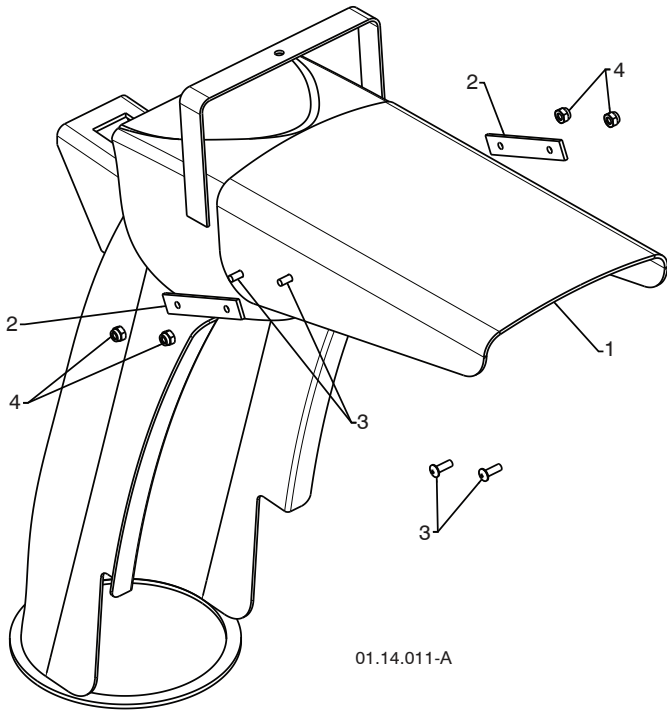

KEY NO.	PART NO.	DESCRIPTION
1	532 42 11-38	SHIELD DEFLECTOR
2	532 42 11-39	STRAP
3	532 18 22-27	SCREW 8-32 X .50
4	532 18 22-28	NUT 8-32

01.14.011-A

**NOTE:** All component dimensions given in U.S. inches. 1 inch = 25.4 mm

**IMPORTANT:** Use only Original Equipment Manufacturer (O.E.M.) replacement parts. Failure to do so could be hazardous, damage your snow thrower and void your warranty.

# REPAIR PARTS

# CONTROL PANEL / DISCHARGE CHUTE

SNOW THROWER - MODEL NO. 12527HVX (96195001800), PRODUCT NO. 961 95 00-18

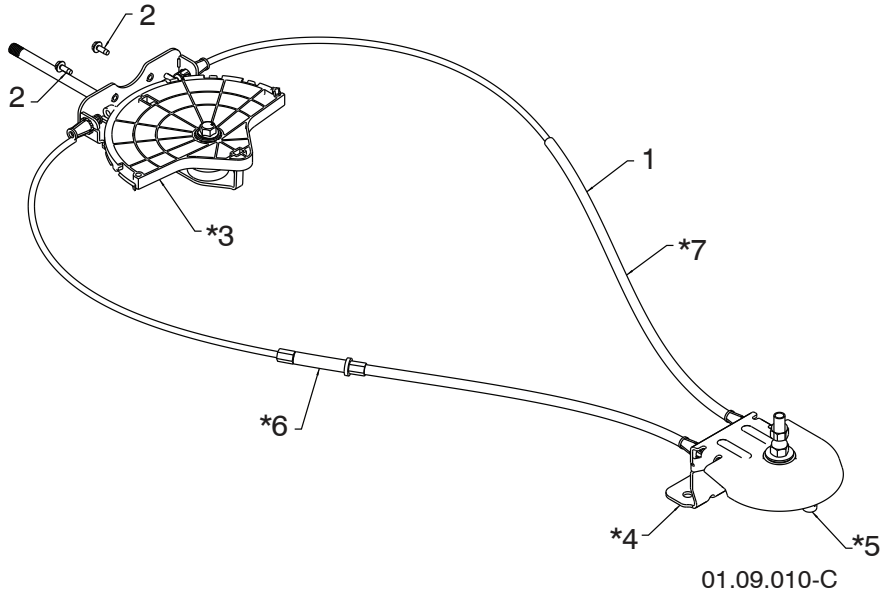

KEY NO.	PART NO.	DESCRIPTION
1	532 42 82-72	LEVER/CABLE ROTATOR ASSEMBLY
2	817 54 10-08	SCREW 10-24 X .625
*3	532 42 06-78	ROTATOR HEAD
*4	532 40 59-32	ROTATOR PIVOT BRACKET
*5	532 42 06-75	PULLEY PIVOT
*6	532 42 82-73	CABLE ASSEMBLY ADJUSTABLE
*7	532 42 83-10	CABLE ASSEMBLY HEAT SHIELD

**NOTES:**

1. ITEMS INDICATED WITH AN \* ARE LISTED AS REFERENCE FOR SERVICE PARTS ONLY.

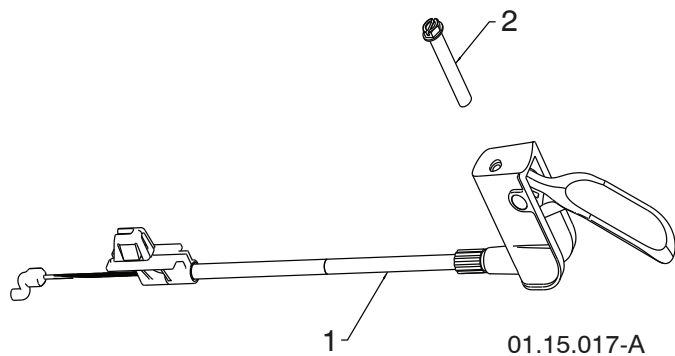

KEY NO.	PART NO.	DESCRIPTION
1	532 43 86-29	STEER CABLE
2	874 04 10-24	SCREW 10-24 X 1.50

**NOTE:** All component dimensions given in U.S. inches. 1 inch = 25.4 mm  
**IMPORTANT:** Use only Original Equipment Manufacturer (O.E.M.) replacement parts. Failure to do so could be hazardous, damage your snow thrower and void your warranty.



# REPAIR PARTS

# HANDLES

SNOW THROWER - MODEL NO. **12527HVX** (96195001800), PRODUCT NO. 961 95 00-18

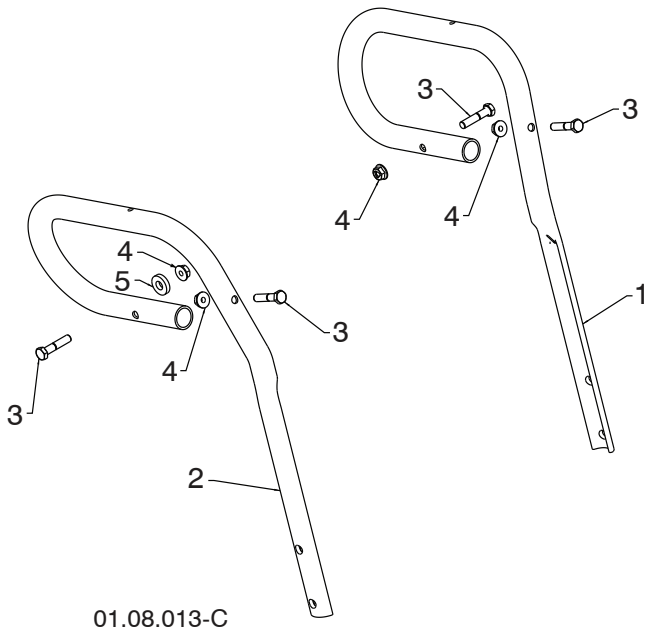

KEY NO.	PART NO.	DESCRIPTION
1	532 42 95-88	LOOP HANDLE LH
2	532 42 95-89	LOOP HANDLE RH
3	874 78 05-24	SCREW 5/16-18 X 1.50
4	532 75 11-53	NUT 5/16-18
5	532 05 56-11	WASHER

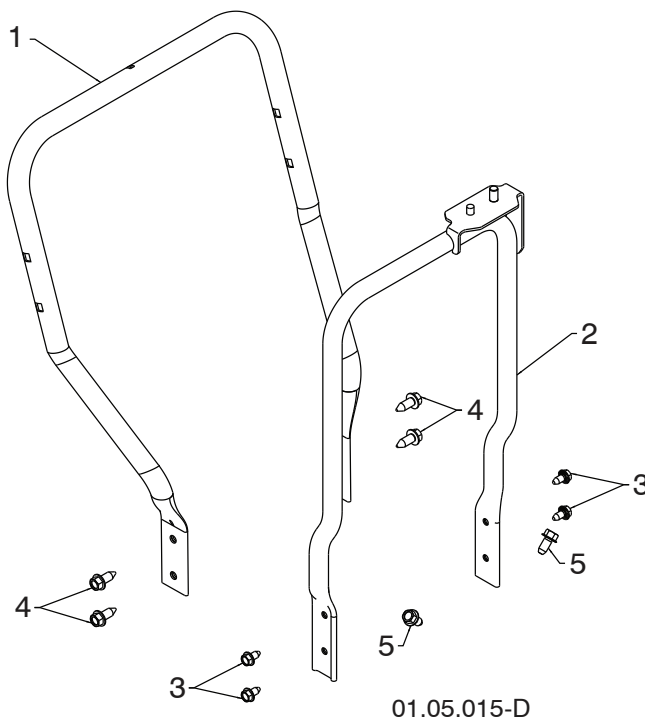

KEY NO.	PART NO.	DESCRIPTION
1	585 23 81-03	LOWER HANDLE
2	532 44 36-17	PIVOT SUPPORT WELDMENT
3	817 00 05-10	SCREW 5/16-18 X .750
4	817 00 06-16	SCREW 3/8-16 X 1.00
5	817 00 06-12	SCREW 3/8-16 X .750

**NOTE:** All component dimensions given in U.S. inches. 1 inch = 25.4 mm  
**IMPORTANT:** Use only Original Equipment Manufacturer (O.E.M.) replacement parts.  
 Failure to do so could be hazardous, damage your snow thrower and void your warranty.

# REPAIR PARTS

# HANDLES

SNOW THROWER - MODEL NO. 12527HVX (96195001800), PRODUCT NO. 961 95 00-18

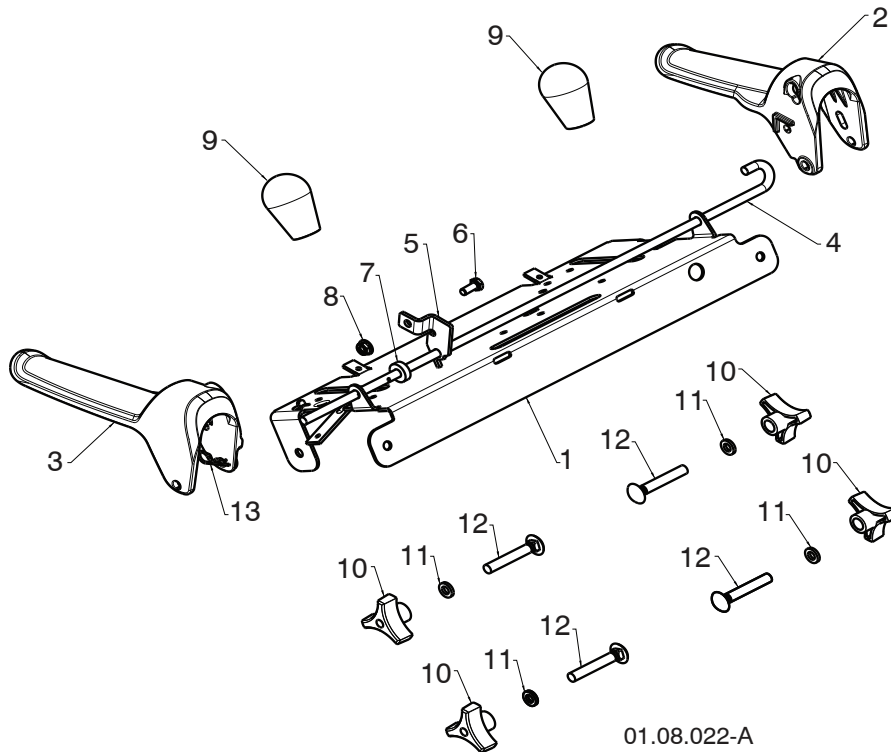

KEY NO.	PART NO.	DESCRIPTION
1	585 19 88-02	CONTROL PANEL
2	581 77 98-01	LH CONTROL LEVER
3	581 77 97-01	RH CONTROL LEVER
4	584 80 90-01	INTERLOCK CONTROL ROD
5	585 00 47-03	INTERLOCK BRACKET
6	874 78 04-10	1/4-20 X .625 HEX HEAD SCREW
7	532 42 16-13	SPACER
8	532 08 83-49	1/4-20 FLANGE NUT (TOP LOCK)
9	580 67 32-01	KNOB SOFT TOUCH
10	532 17 88-99	HANDLE KNOB
11	819 13 13-16	3/8 WASHER
12	872 12 06-18	CARRIAGE BOLT 3/8-16 X 2.25
13	532 16 96-75	RETAINER

**NOTE:** All component dimensions given in U.S. inches. 1 inch = 25.4 mm  
**IMPORTANT:** Use only Original Equipment Manufacturer (O.E.M.) replacement parts. Failure to do so could be hazardous, damage your snow thrower and void your warranty.

# REPAIR PARTS

# HANDLES

SNOW THROWER - MODEL NO. **12527HVX** (96195001800), PRODUCT NO. 961 95 00-18

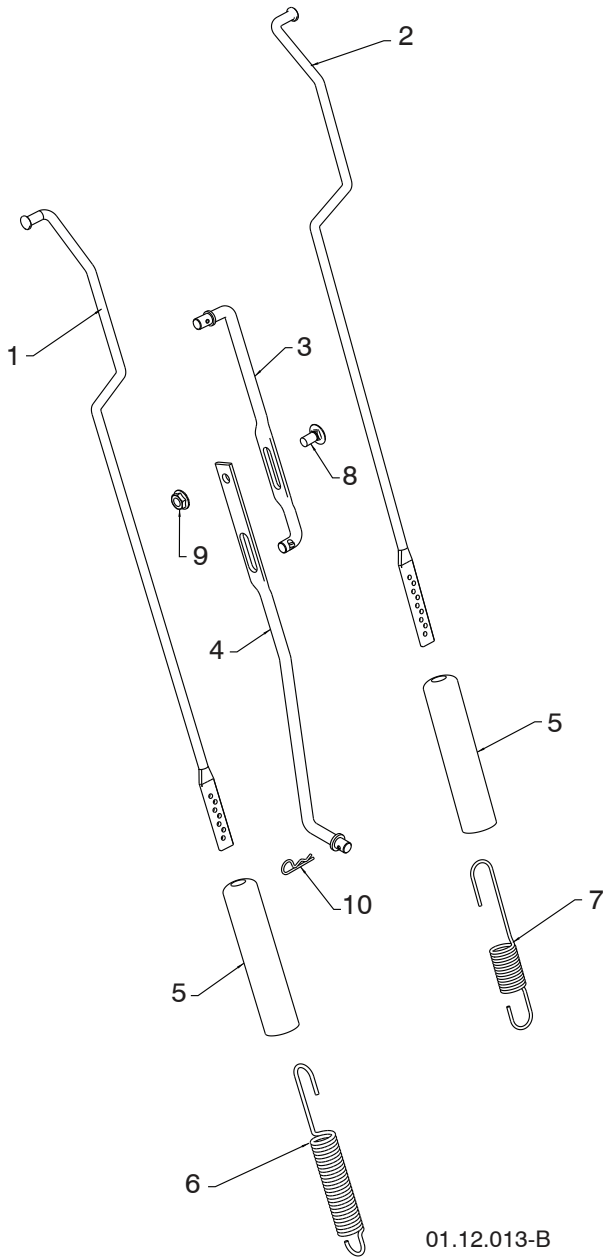

KEY NO.	PART NO.	DESCRIPTION
1	584 80 87-01	ROD IMPELLER CONTROL
2	584 80 88-01	ROD TRACTION CONTROL
3	532 18 04-45	SHIFTER ROD TOP
4	532 18 77-16	SHIFTER ROD BOTTOM
5	532 18 04-47	SPRING SLEEVE
6	580 79 62-01	SPRING CONTROL ROD
7	580 80 21-01	SPRING TRACTION ROD
8	872 27 05-05	CARRIAGE BOLT 5/16-18 X .75
9	532 15 53-77	NUT 5/16-18
10	532 16 96-75	RETAINER HAIRPIN

**NOTE:** HOOK TRACTION ROD SPRING IN HOLE 7  
HOOK IMPELLER ROD SPRING IN HOLE 4

**NOTE:** All component dimensions given in U.S. inches. 1 inch = 25.4 mm  
**IMPORTANT:** Use only Original Equipment Manufacturer (O.E.M.) replacement parts.  
Failure to do so could be hazardous, damage your snow thrower and void your warranty.

# REPAIR PARTS

# HANDLES

SNOW THROWER - MODEL NO. 12527HVX (96195001800), PRODUCT NO. 961 95 00-18

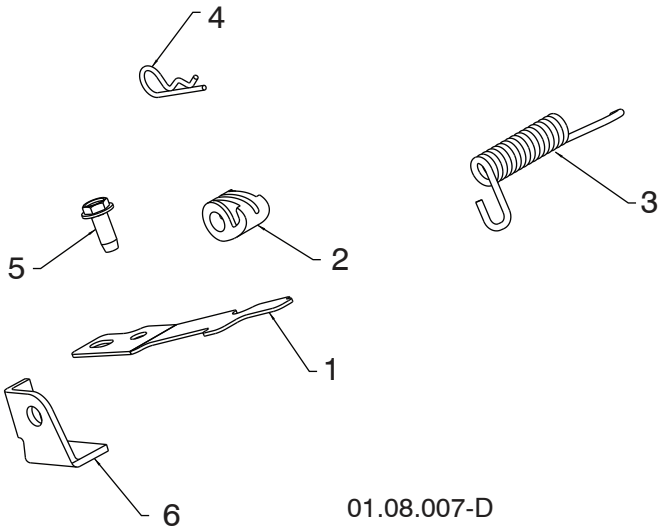

01.08.007-D

KEY NO.	PART NO.	DESCRIPTION
1	532 41 62-88	INTERLOCK SPRING
2	532 44 52-91	INTERLOCK CAM
3	532 44 32-15	TORSION SPRING
4	532 16 96-75	RETAINER
5	817 06 04-10	SCREW 1/4-20 X .625
6	532 42 18-14	INTERLOCK STOP

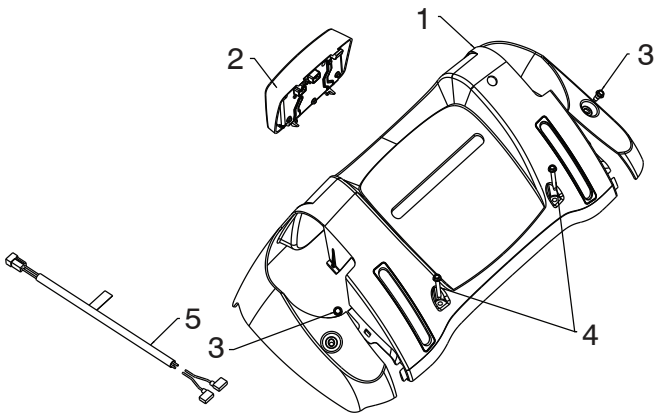

01.10.056-A

KEY NO.	PART NO.	DESCRIPTION
1	532 42 13-82	CONSOLE PANEL
2	581 68 42-01	LED LIGHT
3	532 18 44-71	SHOULDER SCREW 10-24 X .625
4	532 17 52-62	SCREW 10-24 X 1.25
5	532 44 50-29	WIRE HARNESS

**NOTE:** All component dimensions given in U.S. inches. 1 inch = 25.4 mm  
**IMPORTANT:** Use only Original Equipment Manufacturer (O.E.M.) replacement parts.  
 Failure to do so could be hazardous, damage your snow thrower and void your warranty.

# REPAIR PARTS

# DRIVE

SNOW THROWER - MODEL NO. **12527HVX** (96195001800), PRODUCT NO. 961 95 00-18

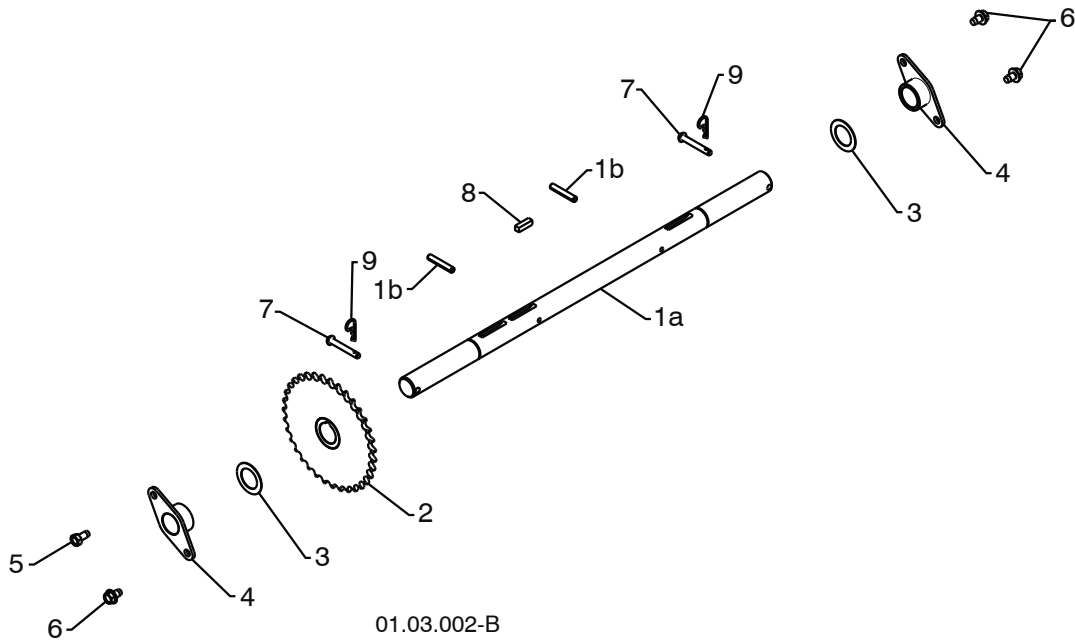

KEY NO.	PART NO.	DESCRIPTION
1	532 40 49-23	AXLE ASSEMBLY (assy of 1a,1b)
1a	532 40 43-07	AXLE SHAFT
1b	532 18 42-06	ROLL PIN 3/16 X 1.50
2	532 40 26-91	SPROCKET
3	532 44 49-49	THRUST WASHER
4	532 17 98-30	BEARING
5	532 14 63-15	SCREW 5/16-18 X .625
6	817 49 05-08	SCREW 5/16-18 X .500
7	532 17 12-71	CLEVIS PIN 1/4 X 1-3/4
8	532 18 92-82	SQUARE KEY
9	532 12 47-88	RETAINER

**NOTE:** All component dimensions given in U.S. inches. 1 inch = 25.4 mm  
**IMPORTANT:** Use only Original Equipment Manufacturer (O.E.M.) replacement parts.  
Failure to do so could be hazardous, damage your snow thrower and void your warranty.

# REPAIR PARTS

# DRIVE

SNOW THROWER - MODEL NO. 12527HVX (96195001800), PRODUCT NO. 961 95 00-18

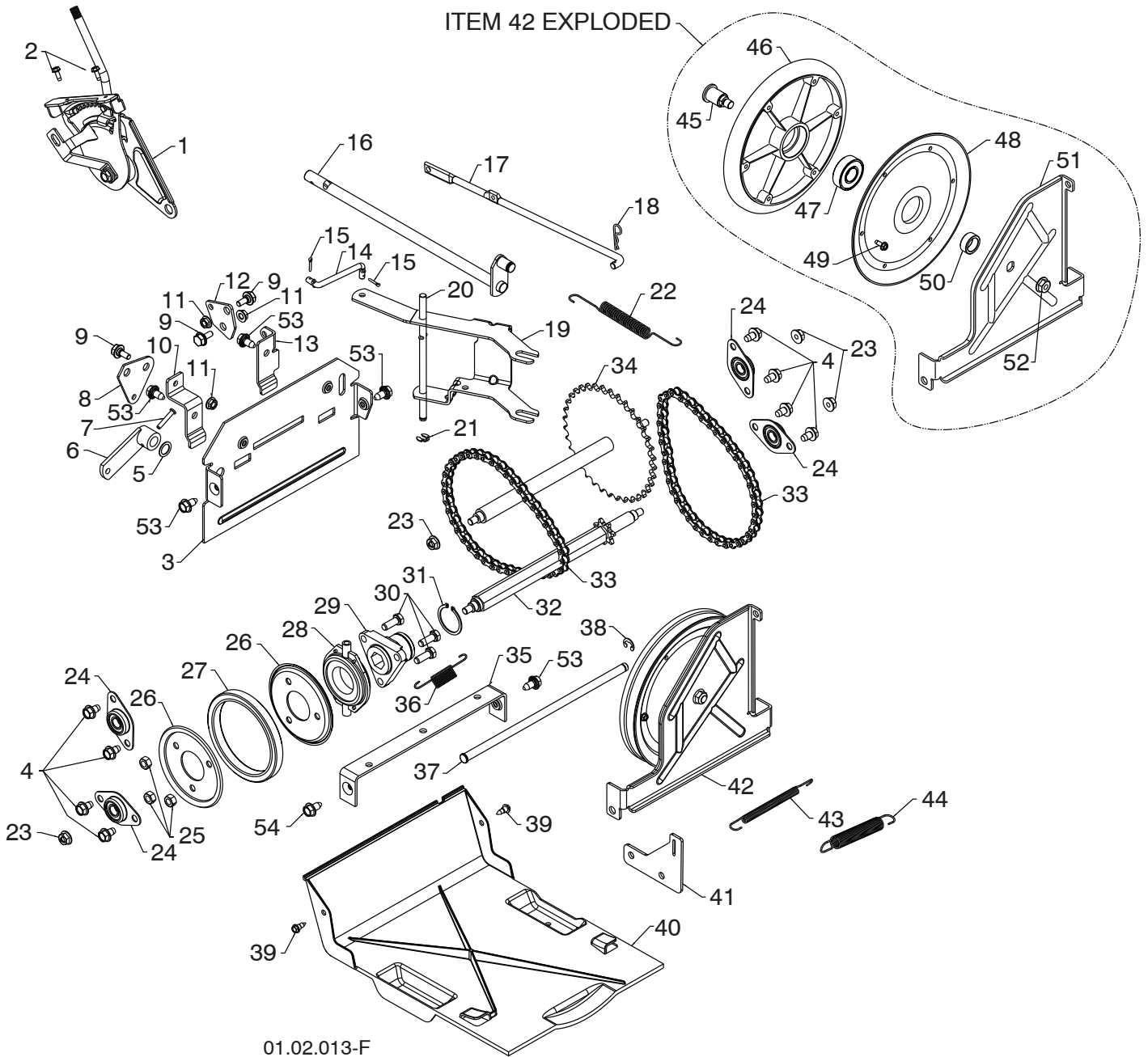

**NOTE:** All component dimensions given in U.S. inches. 1 inch = 25.4 mm  
**IMPORTANT:** Use only Original Equipment Manufacturer (O.E.M.) replacement parts.  
Failure to do so could be hazardous, damage your snow thrower and void your warranty.

**REPAIR PARTS****DRIVE****SNOW THROWER - MODEL NO. 12527HVX (96195001800), PRODUCT NO. 961 95 00-18**

KEY NO.	PART NO.	DESCRIPTION	KEY NO.	PART NO.	DESCRIPTION
1	532 19 88-75	SPEED SELECTOR ASSEMBLY	28	532 17 53-44	BEARING
2	817 54 10-08	THRED ROLLING SCREW 10-24 X .500	29	532 17 86-13	WHEEL HUB
3	532 43 60-80	END PLATE	30	874 76 05-14	SCREW 5/16-18-.875
4	817 49 05-08	SCREW 5/16-18 X .50	31	812 00 00-12	RETAINER RING
5	532 05 70-79	WASHER	32	532 40 21-87	SPROCKET SHAFT
6	532 40 54-85	CONTROL ARM	33	532 40 16-19	CHAIN
7	532 19 85-80	CLEVIS PIN	34	532 43 73-03	SPROCKET WELDMENT
8	532 41 54-50	SHIFTER PLATE	35	532 41 54-29	SHIFTER BRACKET
9	532 40 28-81	SHOULDER BOLT	36	532 18 01-35	SPRING
10	532 41 54-33	SHIFTER BRACKET	37	532 40 26-52	PLATE PIVOT ROD
11	532 19 17-30	NUT 1/4-20	38	532 42 82-88	E-RING .375
12	532 41 54-35	CLUTCH PLATE	39	532 18 44-71	SHOULDER SCREW
13	532 41 68-64	CLUTCH BRACKET	40	532 41 08-77	BOTTOM PAN
14	532 18 71-01	SHIFTER LINK	41	532 41 66-82	SPRING BRACKET
15	532 70 02-79	RETAINER	42	532 40 26-89	DRIVE PLATE ASSEMBLY
16	532 42 75-42	CONTROL SHAFT	43	532 41 45-57	IDLER SPRING
17	532 40 25-68	CLUTCH ROD	44	532 17 88-28	IDLER SPRING
18	532 16 96-75	RETAINER	45	532 40 25-04	PULLEY SHAFT
19	581 42 25-01	SHIFTER YOKE	46	532 40 18-20	DRIVE PLATE
20	532 40 23-10	PIVOT ROD	47	532 19 87-91	BEARING
21	812 00 00-36	RETAINER	48	532 40 23-93	PULLEY HALF
22	532 40 28-78	RETURN SPRING	49	817 54 10-08	SCREW 10-24 X .50
23	532 75 11-53	NUT 5/16-18	50	532 40 25-11	SPACER BEARING
24	532 40 89-81	BEARING	51	532 42 29-41	SWING PLATE
25	873 93 05-00	NUT 5/16-18	52	532 13 20-10	NUT 3/8-16
26	532 19 95-09	RUBBER WHEEL PLATE	53	532 42 88-67	SCREW 5/16-18 X .750
27	585 02 10-01	RUBBER RING	54	817 00 05-10	BOLT 5/16-18 X .625

**NOTE:** All component dimensions given in U.S. inches. 1 inch = 25.4 mm**IMPORTANT:** Use only Original Equipment Manufacturer (O.E.M.) replacement parts. Failure to do so could be hazardous, damage your snow thrower and void your warranty.

# REPAIR PARTS

# CHASSIS / PULLEYS

SNOW THROWER - MODEL NO. 12527HVX (96195001800), PRODUCT NO. 961 95 00-18

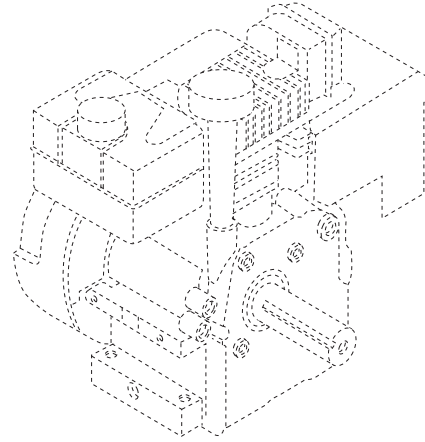
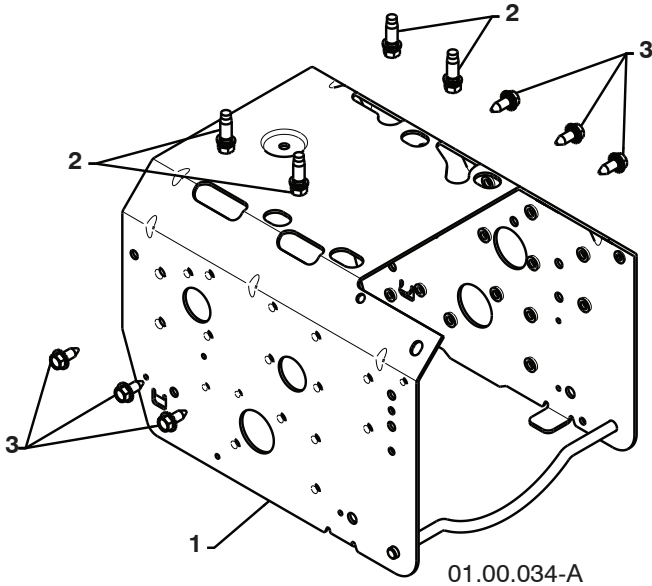

KEY NO.	PART NO.	DESCRIPTION
--	-----	B&S ENGINE MODEL 15C114-2465-F8
1	532 43 59-52	FRAME
2	532 15 04-06	BOLT 3/8-16
3	532 42 88-67	SCREW 5/16-18 X .750

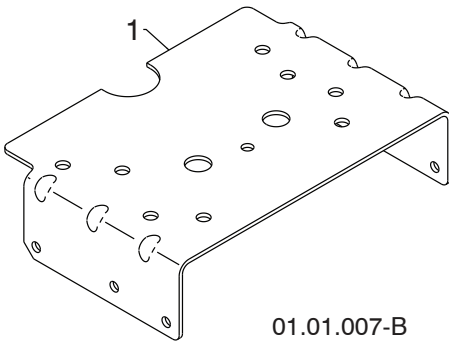

KEY NO.	PART NO.	DESCRIPTION
1	532 43 63-11	ENGINE MOUNT PLATE

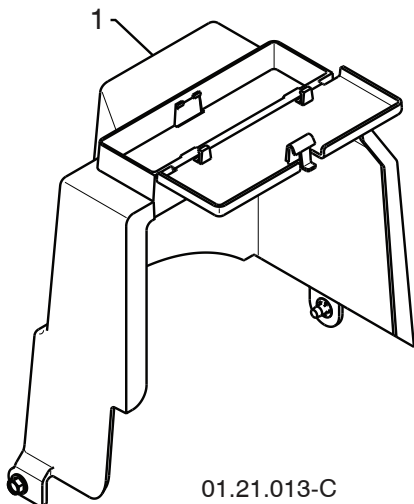

KEY NO.	PART NO.	DESCRIPTION
1	532 44 30-30	COVER ASSEMBLY

**NOTE:** All component dimensions given in U.S. inches. 1 inch = 25.4 mm  
**IMPORTANT:** Use only Original Equipment Manufacturer (O.E.M.) replacement parts.  
 Failure to do so could be hazardous, damage your snow thrower and void your warranty.



# REPAIR PARTS

# CHASSIS / PULLEYS

SNOW THROWER - MODEL NO. **12527HVX** (96195001800), PRODUCT NO. 961 95 00-18

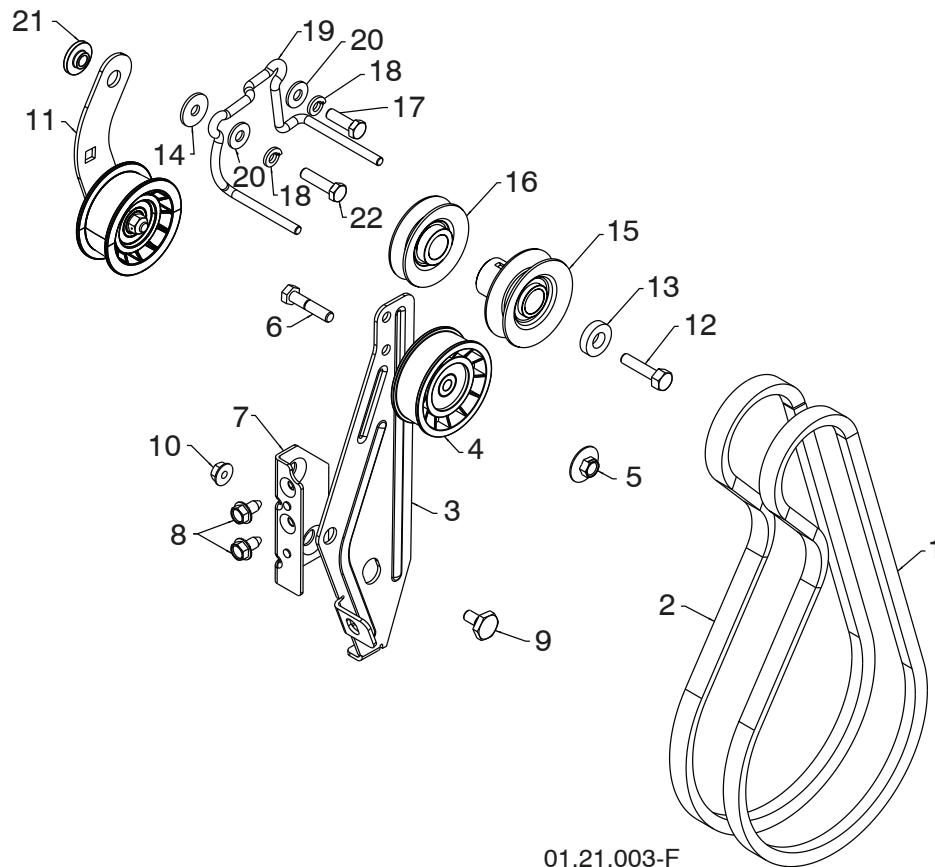

01.21.003-F

KEY NO.	PART NO.	DESCRIPTION	KEY NO.	PART NO.	DESCRIPTION
1	532 40 80-07	IMPELLER BELT	13	532 40 00-26	WASHER
2	532 41 97-44	TRACTION BELT	14	532 05 92-89	WASHER
3	532 18 05-23	IDLER ARM BRACKET	15	532 42 64-90	PULLEY ENG IMPELLER
4	532 18 05-23	IDLER PULLEY	16	532 42 64-90	PULLEY ENG TRACTION
5	532 42 65-89	NUT 5/16-18	17	874 61 05-16	SCREW 5/16-18 X 1.00
6	874 78 05-24	CAPSCREW 5/16-18 X 1.50	18	810 04 05-00	LOCKWASER 5/16
7	532 42 39-90	IDLER BRACKET	19	585 05 82-01	BELT GUIDE
8	817 00 05-10	SCREW 5/16-18 HEX	20	532 15 54-15	WASHER
9	532 42 42-97	SHOULDER BOLT 5/16-18 X .500	21	532 17 53-31	IDLER BUSHING
10	532 75 11-53	NUT 5/16-18 TOP LOCK	22	874 61 05-20	CAPSCREW HEX HEAD 5/16 X 1.25 GR5
11	532 42 64-91	TRACTION IDLER ARM ASM			
12	532 85 10-84	CAPSCREW 3/8-24 X 1.375			

**NOTE:** All component dimensions given in U.S. inches. 1 inch = 25.4 mm  
**IMPORTANT:** Use only Original Equipment Manufacturer (O.E.M.) replacement parts. Failure to do so could be hazardous, damage your snow thrower and void your warranty.

# REPAIR PARTS

# WHEELS

SNOW THROWER - MODEL NO. 12527HVX (96195001800), PRODUCT NO. 961 95 00-18

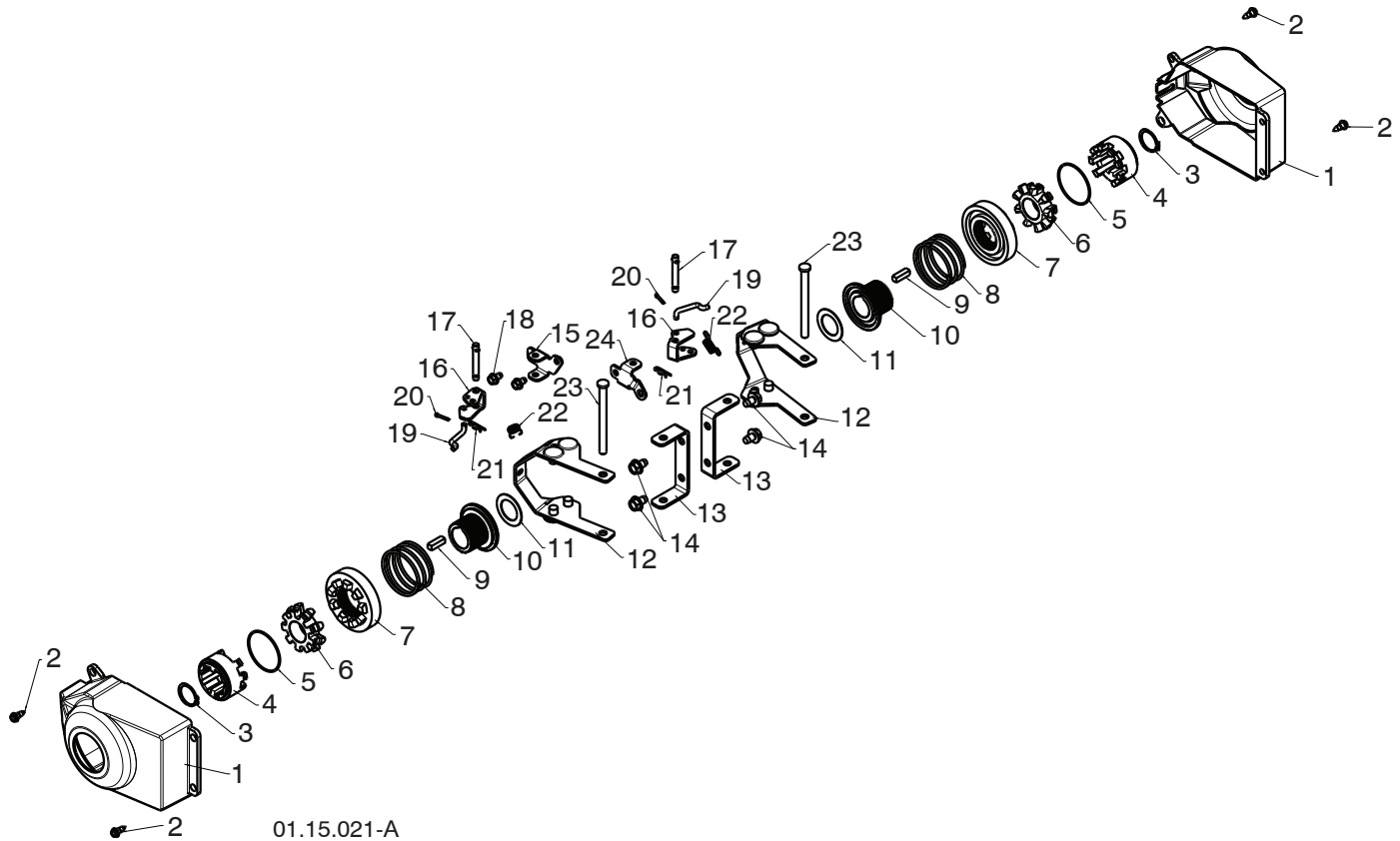

KEY NO.	PART NO.	DESCRIPTION	KEY NO.	PART NO.	DESCRIPTION
1	532 40 51-61	COVER	13	532 18 41-97	STEERING BRACKET
2	532 18 44-71	SHOULDER SCREW	14	817 49 05-08	SCREW 5/16-18 X .50
3	812 00 00-45	RETAINER SPRING	15	532 19 95-11	PIVOT BRACKET
4	581 64 50-01	WHEEL DRIVER	16	532 19 95-18	BELLCRANK
5	532 18 24-66	RETAINING RING	17	532 18 18-47	BELLCRANK PIN
6	532 18 76-22	WHEEL LOBE	18	817 60 04-06	SCREW 1/4-20 X .375
7	581 64 49-01	CLUTCH SLIDE	19	532 40 50-77	STEERING LINK
8	532 17 91-39	SPRING	20	532 70 02-79	RETAINER
9	532 18 92-82	SQUARE KEY	21	532 44 52-66	RETAINER
10	581 64 51-01	AXLE LOBE	22	532 19 38-85	SPRING
11	532 44 49-49	THRUST WASHER	23	532 18 20-15	LEVER PIN
12	532 44 51-79	STEERING YOKE	24	532 19 95-12	PIVOT BRACKET

**NOTE:** All component dimensions given in U.S. inches. 1 inch = 25.4 mm  
**IMPORTANT:** Use only Original Equipment Manufacturer (O.E.M.) replacement parts.  
 Failure to do so could be hazardous, damage your snow thrower and void your warranty.

# REPAIR PARTS

# WHEELS

SNOW THROWER - MODEL NO. **12527HVX** (96195001800), PRODUCT NO. 961 95 00-18

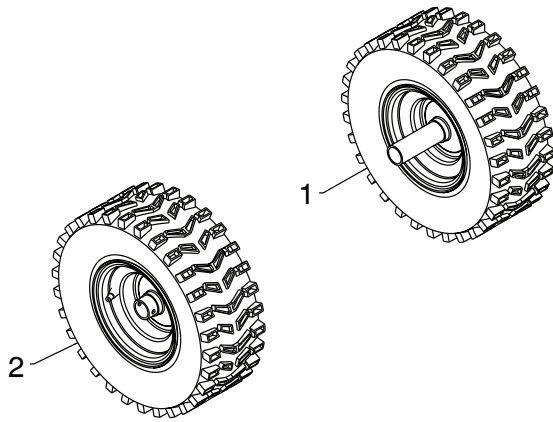

01.06.009-A

KEY NO.	PART NO.	DESCRIPTION
1	532 43 62-53	WHEEL 16 X 4.80 X LH
2	532 43 62-54	WHEEL 16 X 4.80 X RH

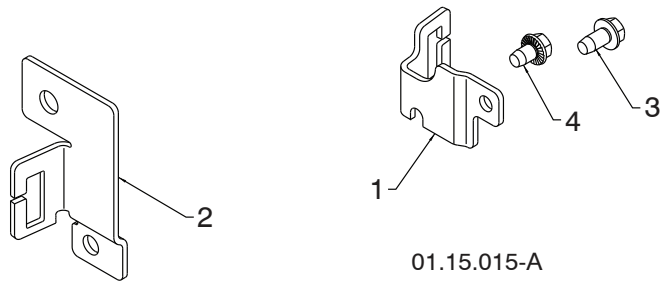

01.15.015-A

KEY NO.	PART NO.	DESCRIPTION
1	532 43 84-46	CABLE BRACKET LH
2	532 43 84-47	CABLE BRACKET RH
3	817 49 04-08	SCREW 1/4 -20 X .500
4	817 60 04-06	SCREW 1/4 -20 X .375

**NOTE:** All component dimensions given in U.S. inches. 1 inch = 25.4 mm  
**IMPORTANT:** Use only Original Equipment Manufacturer (O.E.M.) replacement parts.  
Failure to do so could be hazardous, damage your snow thrower and void your warranty.

# REPAIR PARTS

# BAG OF PARTS

SNOW THROWER - MODEL NO. 12527HVX (96195001800), PRODUCT NO. 961 95 00-18

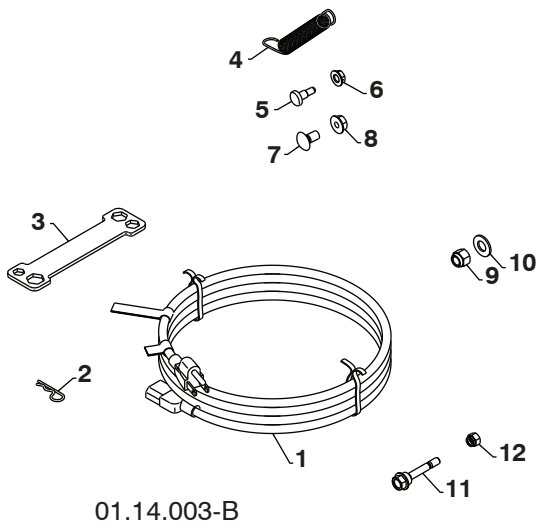

01.14.003-B

KEY NO.	PART NO.	DESCRIPTION
1	532 19 85-63	POWER CORD
2	532 16 96-75	RETAINER PIN
3	532 42 91-12	WRENCH
4	532 18 45-05	REMOTE SPRING
5	532 17 98-29	SHOULDER BOLT 1/4-20
6	532 19 17-30	LOCKNUT 1/4-20
7	872 25 05-05	CARRIAGE BOLT 5/16-18 X 5/8
8	532 75 11-53	LOCKNUT 5/16-18
9	873 80 06-00	LOCKNUT 3/8-16
10	819 13 13-16	WASHER 3/8
11	532 19 20-90	SHEAR BOLT 1/4-20 X 1-13/16
12	873 80 04-00	LOCKNUT 1/4-20

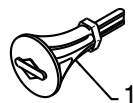

01.14.007-A

KEY NO.	PART NO.	DESCRIPTION
1	532 19 30-71	SAFETY IGNITION KEY

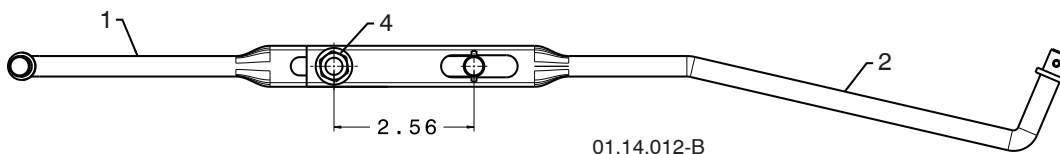
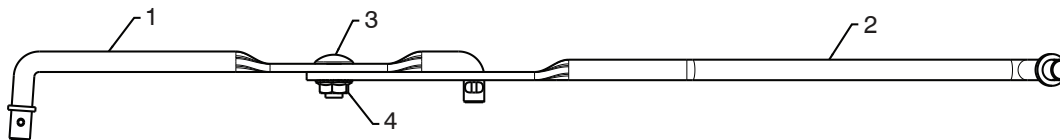

01.14.012-B

KEY NO.	PART NO.	DESCRIPTION
1	532 18 04-45	SHIFTER ROD TOP
2	532 18 77-16	SHIFTER ROD BOTTOM
3	872 27 05-05	CARRIAGE BOLT 5/16-18 X .75
4	532 15 53-77	NUT 5/16-18

**NOTE:** All component dimensions given in U.S. inches. 1 inch = 25.4 mm  
**IMPORTANT:** Use only Original Equipment Manufacturer (O.E.M.) replacement parts. Failure to do so could be hazardous, damage your snow thrower and void your warranty.

# REPAIR PARTS

# DECALS

SNOW THROWER - MODEL NO. **12527HVX** (96195001800), PRODUCT NO. 961 95 00-18

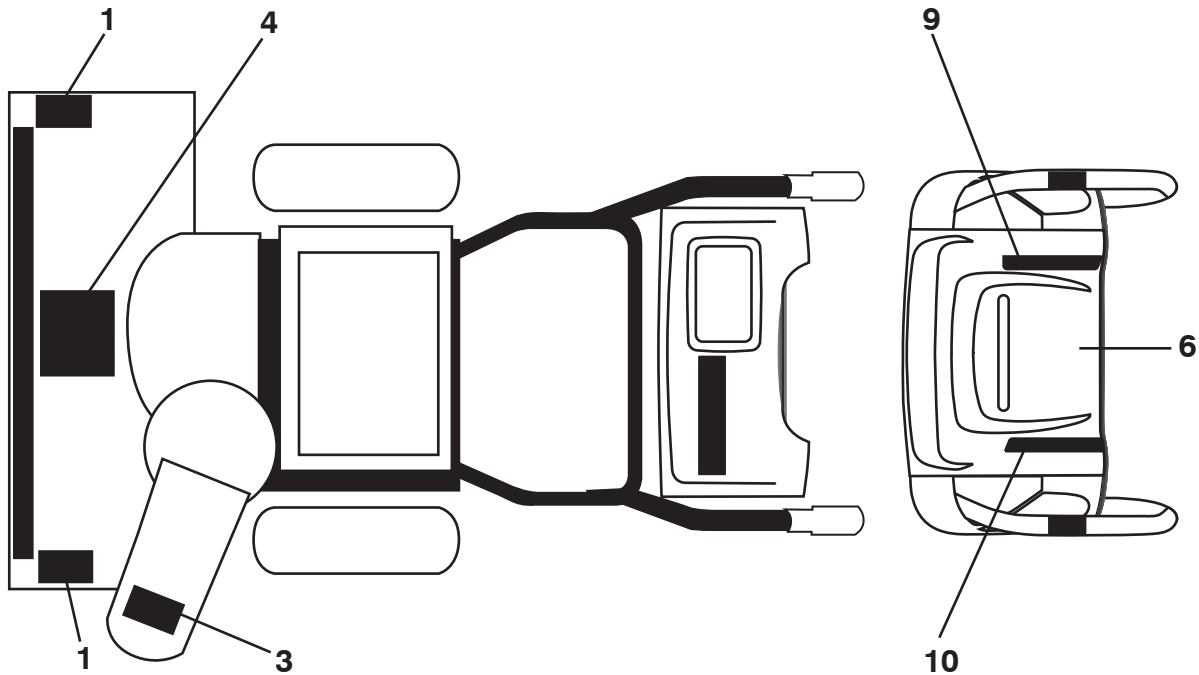

KEY NO.	PART NO.	DESCRIPTION
1	532 18 10-37	DECAL, DANGER
3	532 18 10-35	DECAL, DANGER, DEFLECTOR
4	532 18 10-42	DECAL, DANGER
6	532 42 95-73	DECAL, INSTRUCTION
9	581 43 01-04	DECAL, CONS RT
10	581 43 01-05	DECAL, CONS LT
--	115 59 89-27	OPERATOR'S MANUAL, ENGLISH
--	115 59 90-32	OPERATOR'S MANUAL, FRENCH

**NOTE:** All component dimensions given in U.S. inches. 1 inch = 25.4 mm

**IMPORTANT:** Use only Original Equipment Manufacturer (O.E.M.) replacement parts. Failure to do so could be hazardous, damage your snow thrower and void your warranty.

