

Repair Parts Manual

ST 324P

Gasoline containing up to 10% ethanol (E10) is acceptable for use in this machine.
The use of any gasoline exceeding 10% ethanol (E10) will void the product warranty.

586 83 26-27 Rev. 1



Please read the owner's manual carefully and make sure you understand the instructions before using the machine.



English

HOW TO USE THIS MANUAL

This manual is designed to provide the customer with a means to identify the parts on his/her snow thrower when ordering repair parts. The illustrations may or may not represent the actual assemblies; therefore, it is not recommended to use this manual as a guide to assemble or disassemble the snow thrower. Some hardware and parts are drawn larger in order to more readily identify them.

Each snow thrower has its own model number.

The model and serial numbers will be found on a decal attached to the rear of the snow thrower housing.

When ordering parts, always give the following information:

- Product - "SNOW THROWER"
- MODEL NUMBER - "ST 324P" (96193009101)"
- Part Number
- Part Description

TABLE OF CONTENTS

AUGER HOUSING / IMPELLER ASSEMBLY	3-7
CONTROL PANEL / DISCHARGE CHUTE	8-11
HANDLES	12-14
DRIVE.....	15-17
CHASSIS / ENGINE / PULLEYS	18-19
WHEELS	20
BAG OF PARTS.....	21-22
DECALS.....	23-24
ENGINE BREAKDOWN.....	26-27
WARRANTY.....	28-31

REPAIR PARTS

AUGER HOUSING / IMPELLER ASSEMBLY

SNOW THROWER - MODEL NO. ST 324P (96193009101), PRODUCT NO. 961 93 00-91

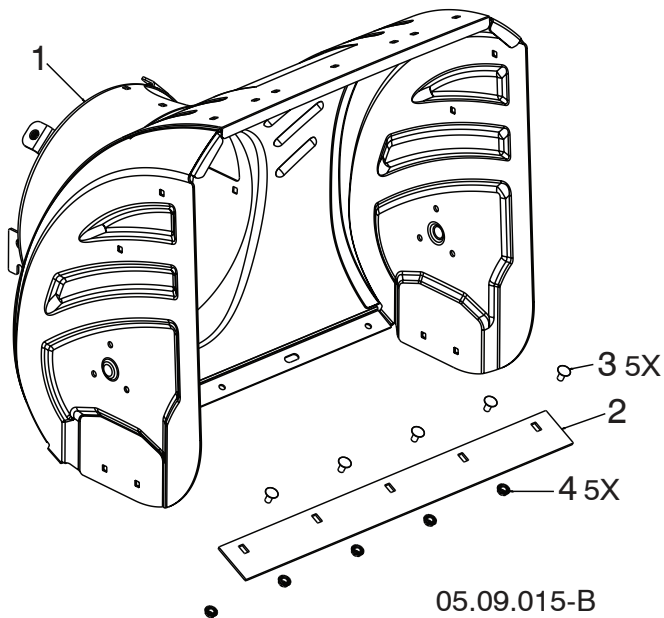

KEY NO.	PART NO.	DESCRIPTION
1	581 97 67-02	AUGER HOUSING 24 LS
2	585 04 83-02	SHAVE PLATE 24 LS MS428
3	872 27 05-05	BOLT CARRIAGE 5/16-18 X .625
4	532 15 53-77	NUT 5/16-18 HEX TOP LOCK

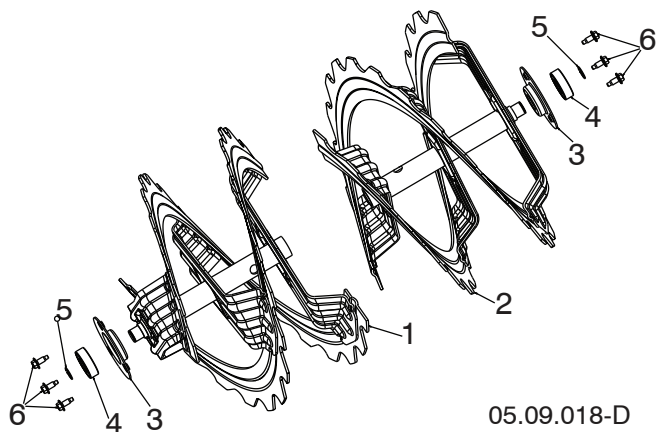

KEY NO.	PART NO.	DESCRIPTION
1	581 97 01-03	AUGER RIBBON 24 RH LS
2	581 97 02-03	AUGER RIBBON 24 LH LS
3	580 85 55-01	SUPPORT AUGER BEARING
4	532 11 04-85	BEARING IDLER 6203
5	812 00 00-28	RING RETAINING #5100-52
6	585 51 78-01	SCREW 1/4-20 X .65 W/DOG POINT

NOTE: All component dimensions given in U.S. inches. 1 inch = 25.4 mm
IMPORTANT: Use only Original Equipment Manufacturer (O.E.M.) replacement parts.
 Failure to do so could be hazardous, damage your snow thrower and void your warranty.

REPAIR PARTS

AUGER HOUSING / IMPELLER ASSEMBLY

SNOW THROWER - MODEL NO. ST 324P (96193009101), PRODUCT NO. 961 93 00-91

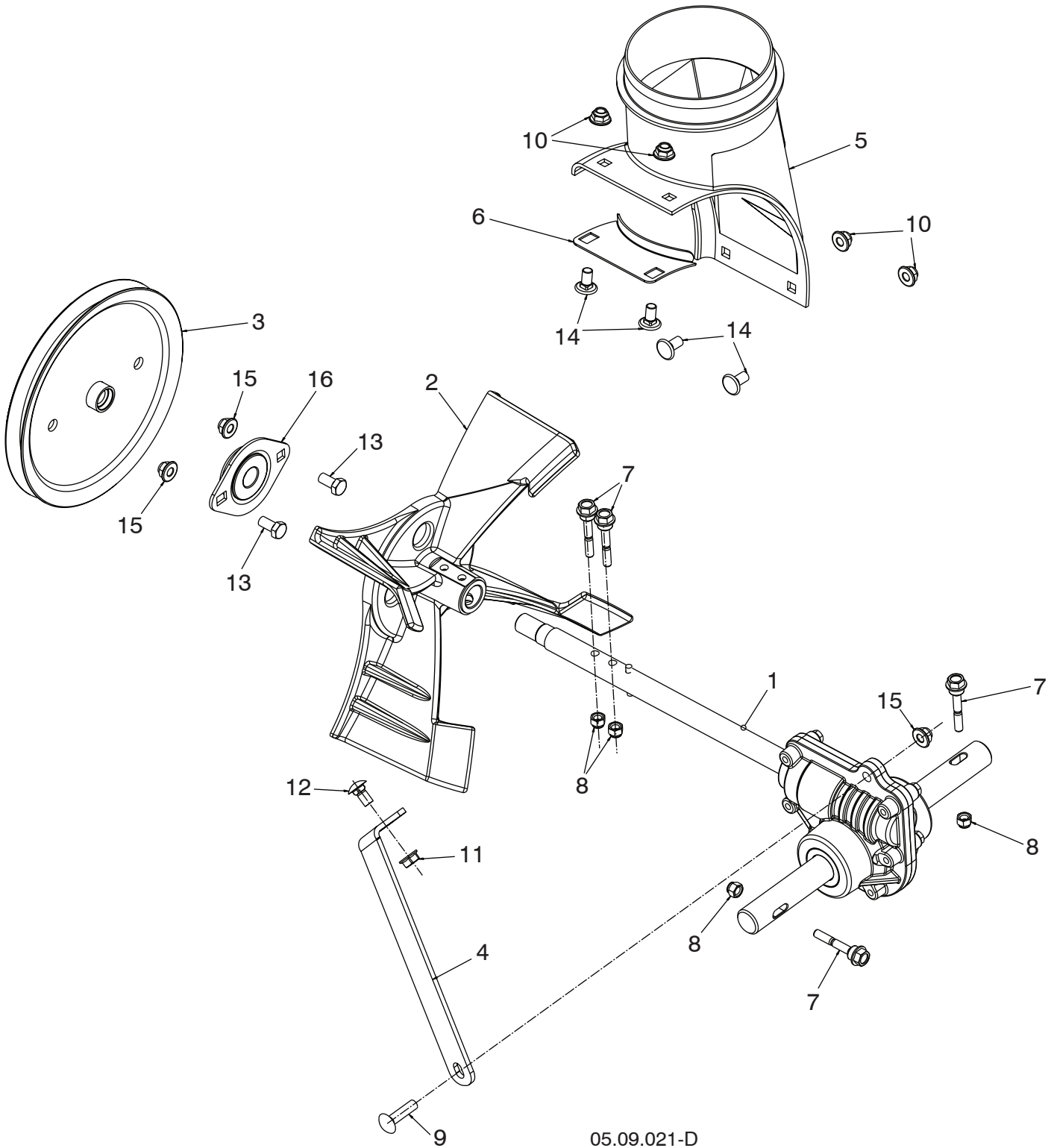

05.09.021-D

NOTE: All component dimensions given in U.S. inches. 1 inch = 25.4 mm
IMPORTANT: Use only Original Equipment Manufacturer (O.E.M.) replacement parts. Failure to do so could be hazardous, damage your snow thrower and void your warranty.

REPAIR PARTS**AUGER HOUSING / IMPELLER ASSEMBLY****SNOW THROWER - MODEL NO. ST 324P (96193009101), PRODUCT NO. 961 93 00-91**

KEY NO.	PART NO.	DESCRIPTION
1	586 71 50-01	GEARBOX AUGER CAST IRON 5/8 THREAD
2	585 19 83-03	IMPELLER CAST IRON
3	586 71 54-01	PULLEY IMPELLER 7.9 SCREW ON
4	585 10 90-04	SUPPORT GEARBOX – GREY
5	585 05 69-01	CHUTE DISCHARGE BASE
6	532 18 40-95	BRACKET CORNER DISCHARGE BASE
7	585 51 18-01	BOLT SHEAR 1/4-20
8	873 80 04-00	NUT NYLOCK 1/4-20
9	872 11 05-10	BOLT CARRIAGE 5/16-18 X 1-1/4
10	585 69 13-01	NUT FLANGE NYLOCK 5/16-18 – BLK
11	532 75 11-53	NUT FLANGE TOP LOCK 5/16-18
12	585 83 20-01	BOLT CARRIAGE 5/16-18 X 5/8 – BLK
13	532 16 31-83	SCREW HEX HEAD 5/16-18 X 5/8
14	585 69 12-01	BOLT CARRIAGE WAFER HEAD 5/16-18 X 5/8 – BLK
15	532 42 79-42	NUT FLANGE NYLOCK 5/16-18
16	532 18 89-09	BEARING FLANGE

NOTE: All component dimensions given in U.S. inches. 1 inch = 25.4 mm

IMPORTANT: Use only Original Equipment Manufacturer (O.E.M.) replacement parts. Failure to do so could be hazardous, damage your snow thrower and void your warranty.

REPAIR PARTS

AUGER HOUSING / IMPELLER ASSEMBLY

SNOW THROWER - MODEL NO. ST 324P (96193009101), PRODUCT NO. 961 93 00-91

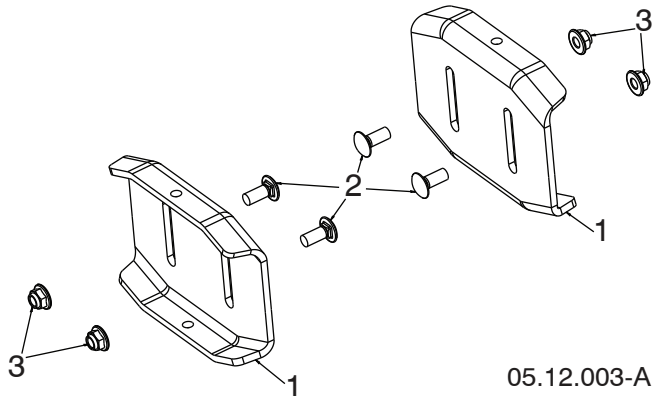

KEY NO.	PART NO.	DESCRIPTION
1	532 40 78-34	SKID PLATE
2	585 69 17-01	BOLT CARRIAGE 5/16-18 X .750 – BLK
3	585 69 13-01	NUT FLANGE NYLOCK 5/16-18 – BLK

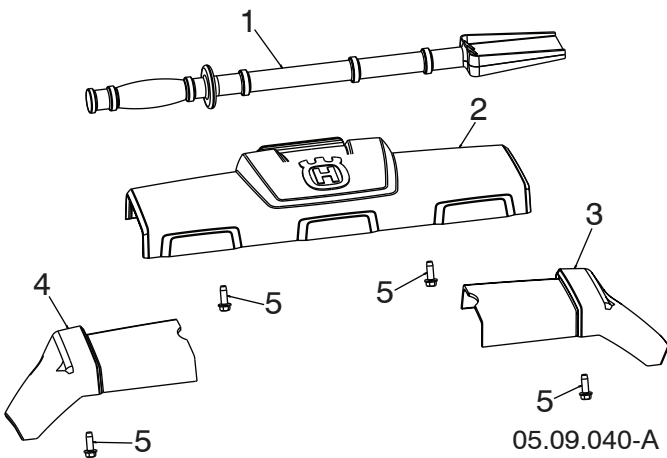

KEY NO.	PART NO.	DESCRIPTION
1	532 19 21-99	TOOL CLEANOUT
2	586 41 48-01	TRIM AUGER HOUSING FRONT ASM
3	586 33 03-02	TRIM AUGER HOUSING WING RH
4	586 33 04-02	TRIM AUGER HOUSING WING LH
5	817 67 04-12	SCREW HEX WASHER TRI-LOBE 1/4-20 X 3/4

NOTE: All component dimensions given in U.S. inches. 1 inch = 25.4 mm
IMPORTANT: Use only Original Equipment Manufacturer (O.E.M.) replacement parts.
 Failure to do so could be hazardous, damage your snow thrower and void your warranty.

REPAIR PARTS

AUGER HOUSING / IMPELLER ASSEMBLY

SNOW THROWER - MODEL NO. ST 324P (96193009101), PRODUCT NO. 961 93 00-91

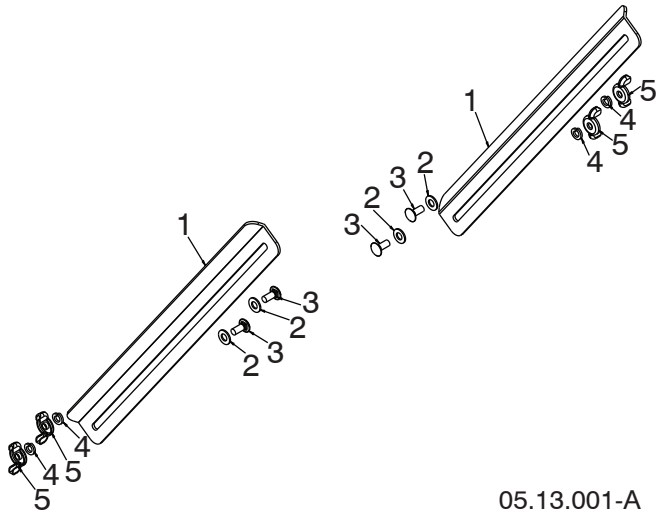

KEY NO.	PART NO.	DESCRIPTION
1	532 18 47-47	DRIFT BAR CUTTER
2	532 17 92-46	WASHER FRICTION NYLON
3	872 27 05-06	CARRIAGE BOLT 5/16-18 X .75 GR5
4	810 04 05-00	LOCKWASHER 5/16 SPLIT
5	532 12 86-38	WING NUT 5/16-18 ZINC

NOTE: All component dimensions given in U.S. inches. 1 inch = 25.4 mm
IMPORTANT: Use only Original Equipment Manufacturer (O.E.M.) replacement parts.
Failure to do so could be hazardous, damage your snow thrower and void your warranty.

REPAIR PARTS

CONTROL PANEL / DISCHARGE CHUTE

SNOW THROWER - MODEL NO. **ST 324P** (96193009101), PRODUCT NO. 961 93 00-91

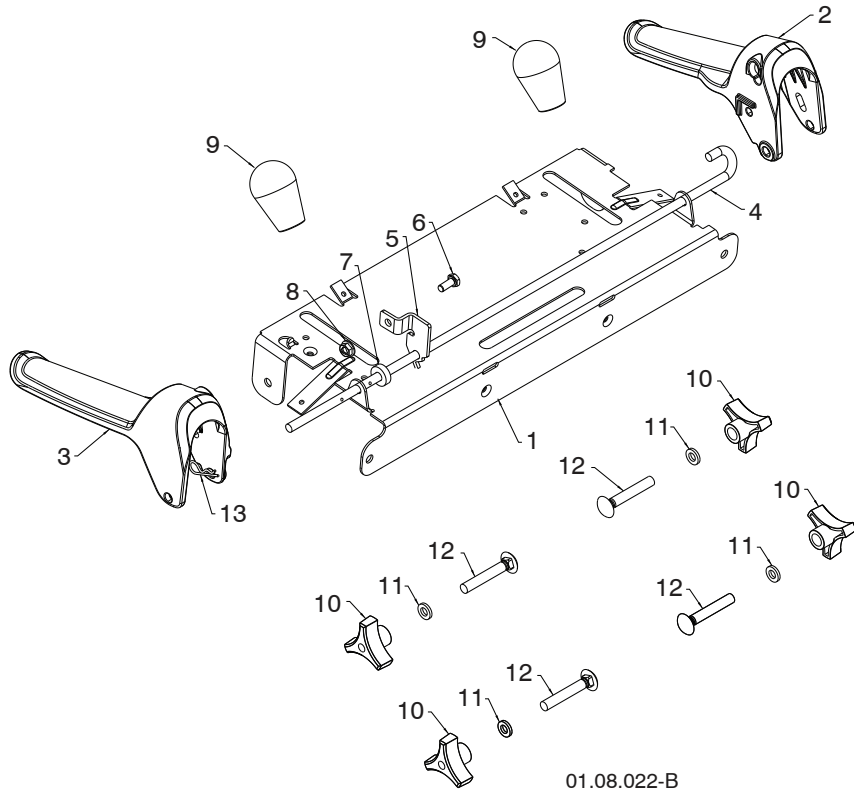

KEY NO.	PART NO.	DESCRIPTION
1	585 19 88-02	CONTROL PANEL
2	581 77 98-01	LH CONTROL LEVER
3	581 77 97-01	RH CONTROL LEVER
4	584 80 90-01	INTERLOCK CONTROL ROD
5	585 00 47-03	INTERLOCK BRACKET
6	874 78 04-10	1/4-20 X .625 HEX HEAD SCREW
7	532 42 16-13	SPACER
8	532 08 83-49	1/4-20 FLANGE NUT (TOP LOCK)
9	580 67 32-01	KNOB SOFT TOUCH
10	532 17 88-99	HANDLE KNOB
11	819 13 13-16	3/8 WASHER
12	872 12 06-18	CARRIAGE BOLT 3/8-16 X 2.25
13	532 16 96-75	RETAINER

NOTE: All component dimensions given in U.S. inches. 1 inch = 25.4 mm
IMPORTANT: Use only Original Equipment Manufacturer (O.E.M.) replacement parts. Failure to do so could be hazardous, damage your snow thrower and void your warranty.

REPAIR PARTS

CONTROL PANEL / DISCHARGE CHUTE

SNOW THROWER - MODEL NO. ST 324P (96193009101), PRODUCT NO. 961 93 00-91

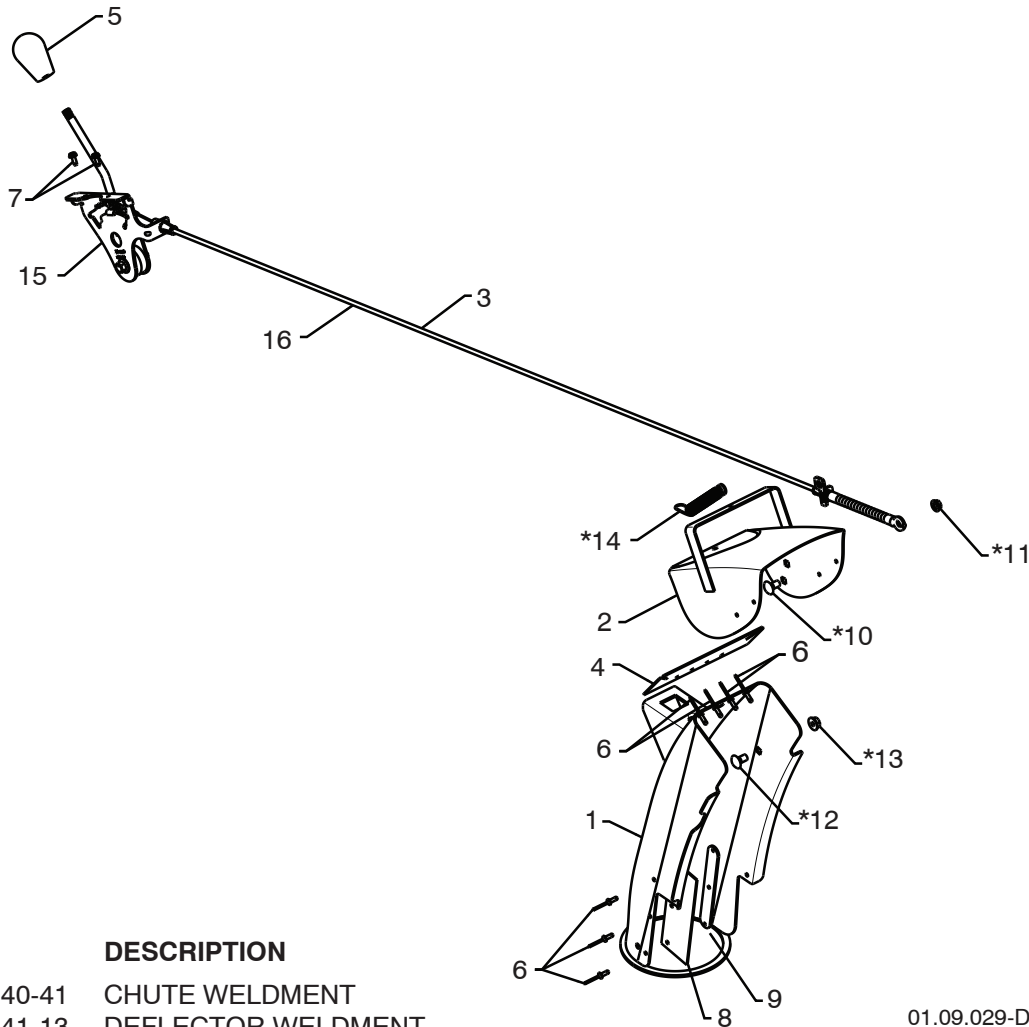

01.09.029-D

KEY NO.	PART NO.	DESCRIPTION
1	532 44 40-41	CHUTE WELDMENT
2	532 18 41-13	DEFLECTOR WELDMENT
3	587 03 08-01	DEFLECTOR CONTROL ASSEMBLY
4	532 42 03-25	DEFLECTOR SEAL
5	580 67 32-01	KNOB OVERMOLD BLACK
6	532 12 84-15	POP RIVET
7	817 54 10-08	THREAD ROLLING SCREW 10-24 X .500
8	532 43 03-24	CHUTE SNOW SHIELD
9	532 42 17-28	SHIELD RETAINER STRAP
*10	532 17 98-29	SHOULDER BOLT 1/4-20 X .375
*11	532 19 17-30	NUT 1/4-20
*12	585 83 20-01	CARRIAGE BOLT BLACK 5/16-18 X 5/8
*13	532 75 11-53	NUT 5/16-18
*14	532 18 45-05	DEFLECTOR SPRING
15	585 27 16-01	(SERVICE PART) DEFLECTOR CONTROL
16	587 03 09-01	(SERVICE PART) DEFLECTOR CABLE BLACK

NOTE:

1. ALL ITEMS INDICATED WITH AN * ARE PROVIDED IN THE BAG OF ITEMS SHIPPED LOOSE WITH PRODUCT.
2. ITEMS 15 AND 16 ARE SERVICE PART NUMBERS TO ALLOW PURCHASE OF INDIVIDUAL ITEMS IF NECESSARY.

NOTE: All component dimensions given in U.S. inches. 1 inch = 25.4 mm
IMPORTANT: Use only Original Equipment Manufacturer (O.E.M.) replacement parts.
 Failure to do so could be hazardous, damage your snow thrower and void your warranty.

REPAIR PARTS

CONTROL PANEL / DISCHARGE CHUTE

SNOW THROWER - MODEL NO. ST 324P (96193009101), PRODUCT NO. 961 93 00-91

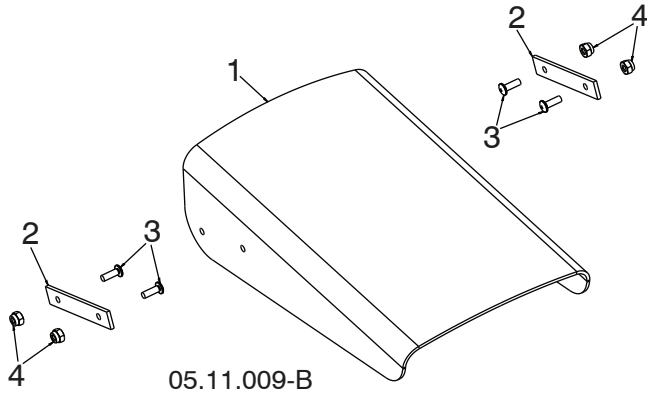

KEY NO.	PART NO.	DESCRIPTION
1	532 42 11-38	SHIELD DEFLECTOR
2	532 42 32-47	STRAP
3	586 11 80-01	SCREW MACHINE 8-32 X .50 BLK
4	586 11 81-01	NUT HEX NYLOCK 8-32 - BLK

NOTE: All component dimensions given in U.S. inches. 1 inch = 25.4 mm
IMPORTANT: Use only Original Equipment Manufacturer (O.E.M.) replacement parts.
Failure to do so could be hazardous, damage your snow thrower and void your warranty.

REPAIR PARTS

CONTROL PANEL / DISCHARGE CHUTE

SNOW THROWER - MODEL NO. ST 324P (96193009101), PRODUCT NO. 961 93 00-91

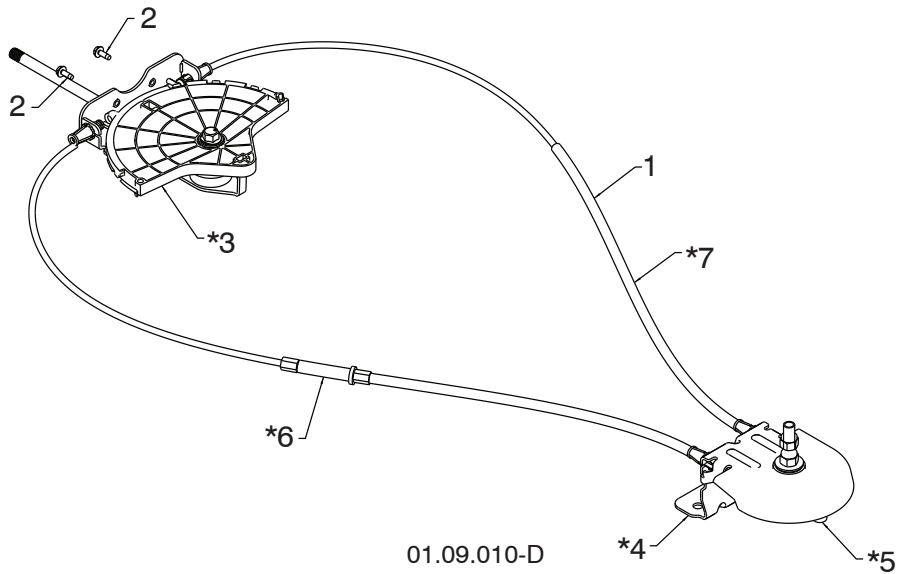

KEY NO.	PART NO.	DESCRIPTION
1	532 42 82-72	LEVER/CABLE ROTATOR ASSEMBLY
2	817 54 10-08	THREAD ROLLING SCREW 10-24 X .500
*3	532 42 06-78	ROTATOR HEAD
*4	585 19 92-01	ROTATOR PIVOT BRACKET
*5	532 42 06-75	PULLEY PIVOT
*6	532 42 82-73	CABLE ASSEMBLY ADJUSTABLE
*7	532 42 83-10	CABLE ASSEMBLY HEAT SHIELD

NOTES:

1. ITEMS INDICATED WITH AN * ARE LISTED AS REFERENCE FOR SERVICE PARTS ONLY.

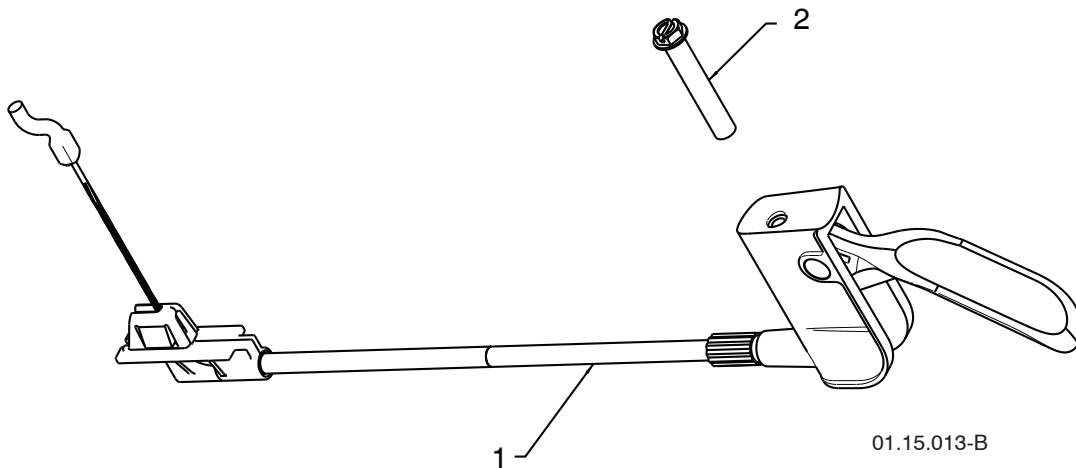

KEY NO.	PART NO.	DESCRIPTION
1	532 42 57-99	STEER CABLE
2	874 04 10-24	SCREW 10-24 X 1.50

NOTE: All component dimensions given in U.S. inches. 1 inch = 25.4 mm
IMPORTANT: Use only Original Equipment Manufacturer (O.E.M.) replacement parts. Failure to do so could be hazardous, damage your snow thrower and void your warranty.

REPAIR PARTS

HANDLES

SNOW THROWER - MODEL NO. ST 324P (96193009101), PRODUCT NO. 961 93 00-91

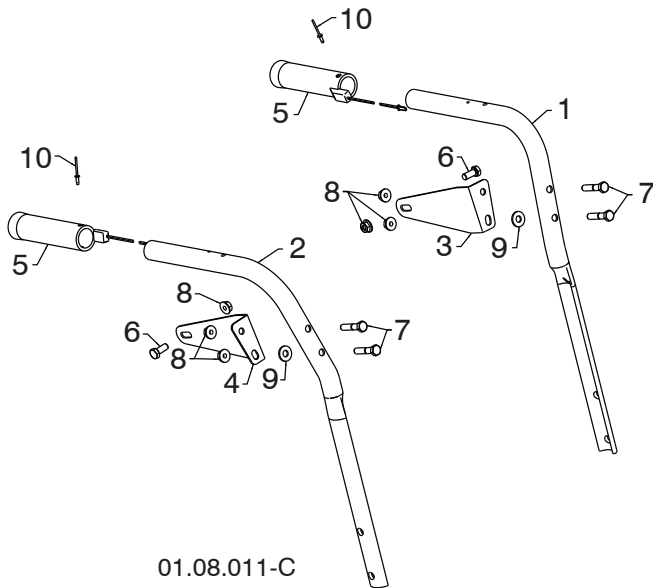

KEY NO.	PART NO.	DESCRIPTION
1	532 42 17-08	PLOW HANDLE LH
2	532 42 17-09	PLOW HANDLE RH
3	532 42 91-48	PANEL BRACKET LH
4	532 42 91-49	PANEL BRACKET RH
5	532 41 45-15	HEATED HANDLE GRIP
6	874 78 05-12	SCREW 5/16-18 X .750
7	874 78 05-24	SCREW 5/16-18 X 1.50
8	532 75 11-53	NUT 5/16-18
9	532 15 54-15	WASHER
10	532 17 87-75	POP RIVET 1/8

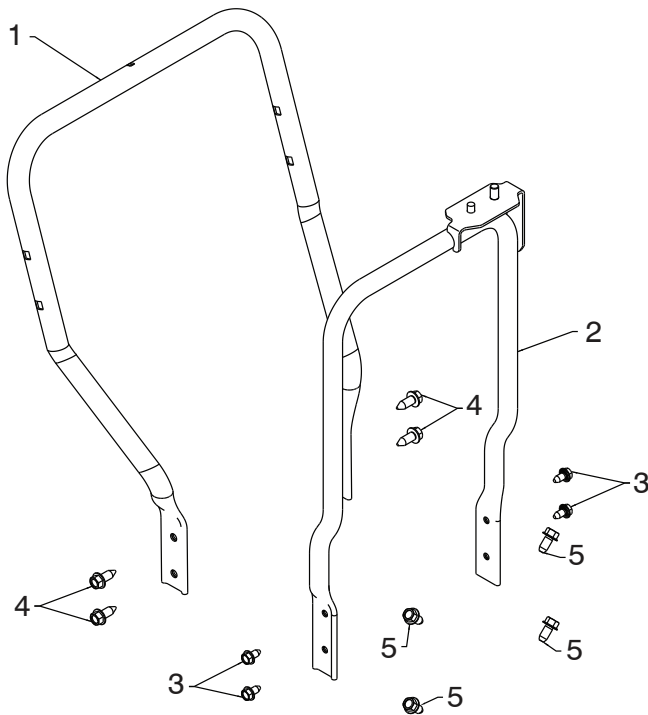

KEY NO.	PART NO.	DESCRIPTION
1	585 23 81-03	LOWER HANDLE
2	532 44 36-17	PIVOT SUPPORT WELDMENT
3	817 00 05-10	SCREW 5/16-18 X .750
4	817 00 06-16	SCREW 3/8-16 X 1.00
5	817 00 06-12	SCREW 3/8-16 X .750

NOTE: All component dimensions given in U.S. inches. 1 inch = 25.4 mm
IMPORTANT: Use only Original Equipment Manufacturer (O.E.M.) replacement parts.
 Failure to do so could be hazardous, damage your snow thrower and void your warranty.

REPAIR PARTS

HANDLES

SNOW THROWER - MODEL NO. ST 324P (96193009101), PRODUCT NO. 961 93 00-91

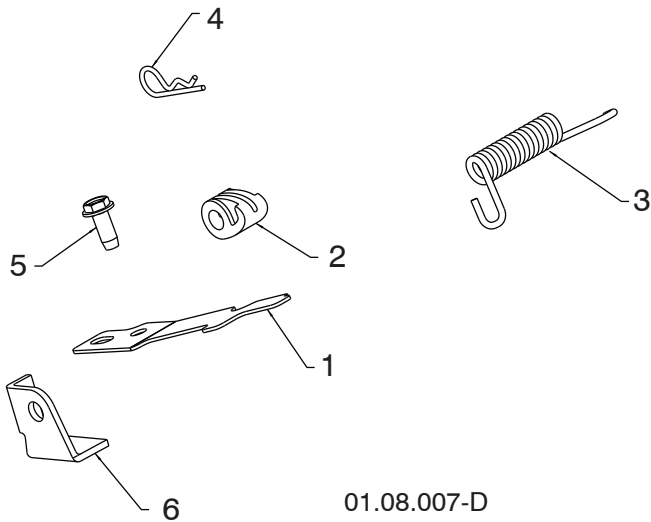

KEY NO.	PART NO.	DESCRIPTION
1	532 41 62-88	INTERLOCK SPRING
2	532 44 52-91	INTERLOCK CAM
3	532 44 32-15	TORSION SPRING
4	532 16 96-75	RETAINER
5	817 06 04-10	SCREW 1/4-20 X .625
6	532 42 18-14	INTERLOCK STOP

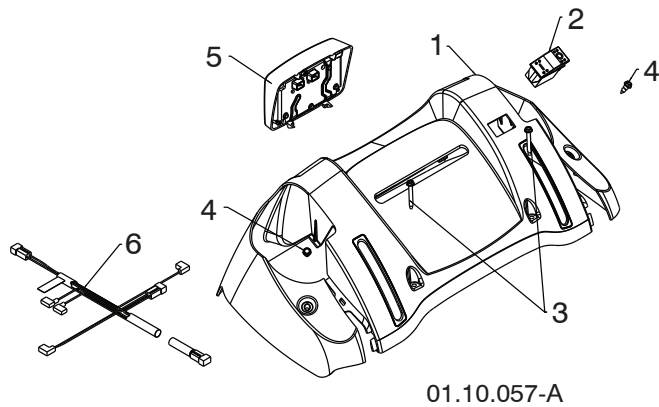

KEY NO.	PART NO.	DESCRIPTION
1	532 42 13-51	CONSOLE PANEL
2	532 41 77-60	SWITCH GRIP
3	532 17 52-62	SCREW HX WHSR HEAD 10-24 X 1.25
4	532 18 44-71	SCREW SHOULDER 10-24 X .62
5	581 68 42-01	LED LIGHT DUAL STAGE GRAY
6	580 62 56-01	WIRE HARNESS FLOOD / LED HEATED

NOTE: All component dimensions given in U.S. inches. 1 inch = 25.4 mm
IMPORTANT: Use only Original Equipment Manufacturer (O.E.M.) replacement parts.
 Failure to do so could be hazardous, damage your snow thrower and void your warranty.

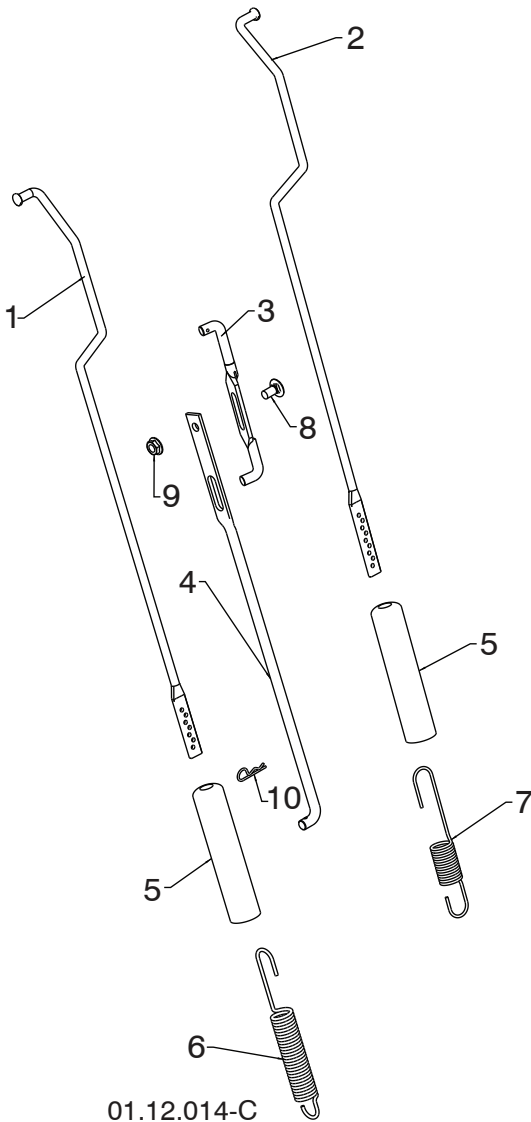

KEY NO.	PART NO.	DESCRIPTION
1	584 80 87-01	ROD IMPELLER CONTROL
2	584 80 88-01	ROD TRACTION CONTROL
3	532 42 55-98	SHIFTER ROD TOP
4	532 18 77-84	SHIFTER ROD BOTTOM
5	532 18 04-47	SPRING SLEEVE
6	580 79 62-01	SPRING CONTROL ROD
7	580 80 21-01	SPRING TRACTION ROD
8	872 27 05-05	CARRIAGE BOLT 5/16-18 X .75
9	532 15 53-77	NUT 5/16-18
10	532 16 96-75	RETAINER HAIRPIN

NOTE: HOOK TRACTION ROD SPRING IN HOLE 9
 HOOK IMPELLER ROD SPRING IN HOLE 4

01.12.014-C

NOTE: All component dimensions given in U.S. inches. 1 inch = 25.4 mm
IMPORTANT: Use only Original Equipment Manufacturer (O.E.M.) replacement parts.
 Failure to do so could be hazardous, damage your snow thrower and void your warranty.

REPAIR PARTS

DRIVE

SNOW THROWER - MODEL NO. ST 324P (96193009101), PRODUCT NO. 961 93 00-91

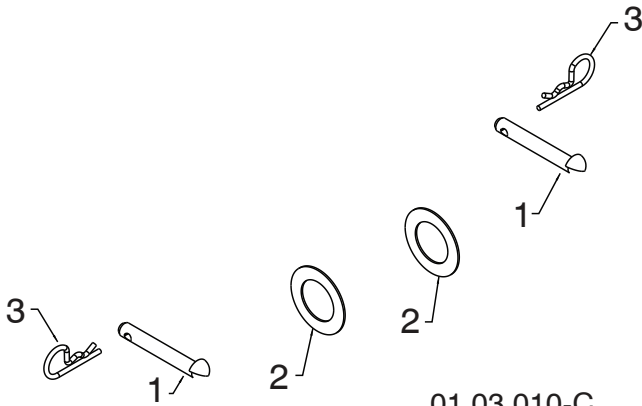

KEY NO.	PART NO.	DESCRIPTION
1	532 17 12-71	RIVET
2	532 12 49-31	THRUST WASHER
3	532 12 47-88	RETAINER

NOTE: All component dimensions given in U.S. inches. 1 inch = 25.4 mm
IMPORTANT: Use only Original Equipment Manufacturer (O.E.M.) replacement parts. Failure to do so could be hazardous, damage your snow thrower and void your warranty.

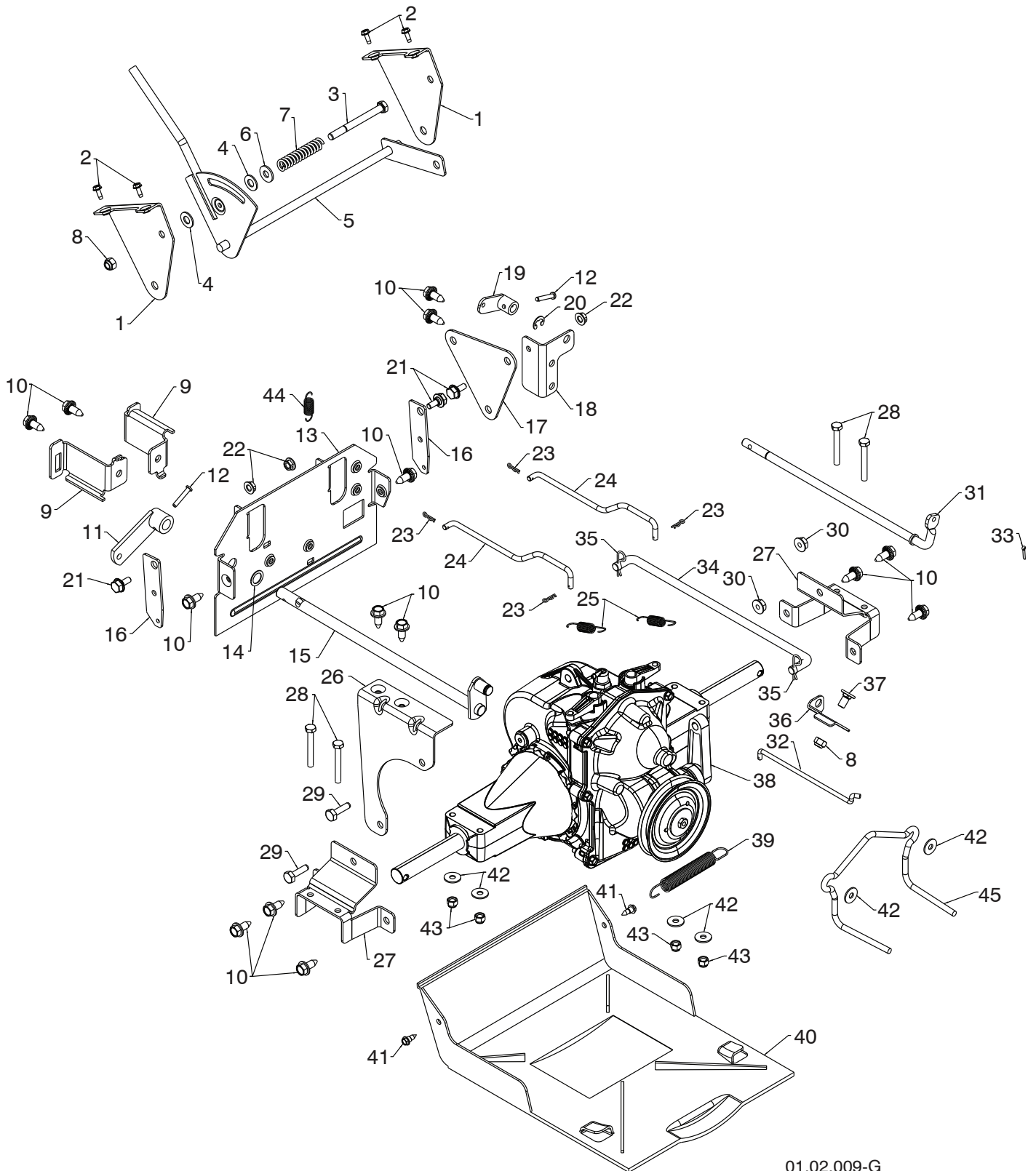

01.02.009-G

NOTE: All component dimensions given in U.S. inches. 1 inch = 25.4 mm
IMPORTANT: Use only Original Equipment Manufacturer (O.E.M.) replacement parts. Failure to do so could be hazardous, damage your snow thrower and void your warranty.

REPAIR PARTS**DRIVE****SNOW THROWER - MODEL NO. ST 324P (96193009101), PRODUCT NO. 961 93 00-91**

KEY NO.	PART NO.	DESCRIPTION	KEY NO.	PART NO.	DESCRIPTION
1	532 44 33-44	SHIFT BRACKET	23	532 06 53-22	HAIRPIN RETAINER SMALL
2	817 54 10-08	THREAD ROLLING SCREW 10-24 X .500	24	532 42 54-96	STEER ROD
3	874 76 05-52	SCREW 5/16-18 X 3.25	25	532 19 41-24	RETURN SPRING
4	532 17 92-46	PLASTIC WASHER	26	532 44 33-46	STABILIZER BRACKET
5	532 42 55-96	SHIFT ASSEMBLY	27	532 44 33-45	TRANSMISSION MOUNTING BRACKET
6	532 15 54-15	WASHER	28	874 88 04-32	SCREW 1/4-20 X 2.00
7	532 19 21-95	FRICTION SPRING	29	874 76 05-16	BOLT 5/16-18 X 1.00
8	873 80 05-00	NUT 5/16-18 LOCK	30	532 75 11-53	NUT 5/16-18 TOP LOCK
9	532 44 33-47	CABLE MOUNTING BRACKET RH	31	532 19 82-51	CLUTCH SHAFT
10	532 42 88-67	SCREW 5/16-18 X .750	32	532 44 62-93	CLUTCH ROD
11	532 40 54-85	CONTROL ARM	33	532 70 02-79	RETAINER CLIP
12	532 19 85-80	CLEVIS PIN	34	532 42 54-99	SPEED CONTROL ROD
13	532 43 71-51	REAR PLATE	35	532 16 96-75	HAIRPIN RETAINER LARGE
14	532 05 70-79	WASHER	36	532 42 98-03	FRONT CLUTCH BRACKET
15	532 42 75-42	CONTROL SHAFT	37	532 18 03-55	CARRIAGE BOLT 5/16-18 X .625
16	532 44 33-50	STEER LEVER	38	532 42 53-94	HYDROSTATIC TRANSMISSION
17	532 44 33-49	PIVOT PLATE	39	532 17 88-28	BRAKE SPRING
18	532 44 33-48	REAR CLUTCH BRACKET	40	532 42 54-98	BOTTOM PAN
19	532 19 82-49	CLUTCH ARM	41	532 18 44-71	SHOULDER SCREW 10-24
20	532 42 82-88	E-RING .375	42	532 05 38-47	WASHER
21	532 40 28-81	SHOULDER BOLT 1/4-20	43	873 80 04-00	NUT 1/4-20 NYLOCK
22	532 19 17-30	NUT 1/4-20 SIDELOCK	44	532 40 65-58	RETURN SPRING
			45	584 99 45-01	BELT GUIDE HYDRO 2

NOTE: All component dimensions given in U.S. inches. 1 inch = 25.4 mm

IMPORTANT: Use only Original Equipment Manufacturer (O.E.M.) replacement parts. Failure to do so could be hazardous, damage your snow thrower and void your warranty.

REPAIR PARTS

CHASSIS / ENGINE / PULLEYS

SNOW THROWER - MODEL NO. ST 324P (96193009101), PRODUCT NO. 961 93 00-91

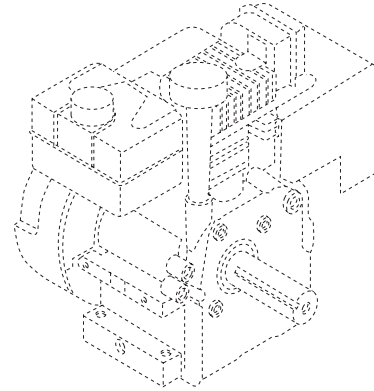
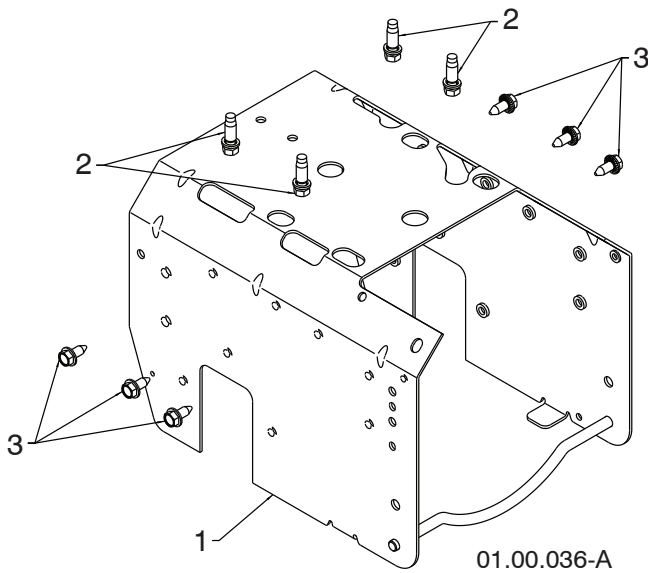

KEY NO.	PART NO.	DESCRIPTION
--	585 33 57-03	COMPLETE LCT ENGINE PW2HK18750178E
1	586 50 78-03	FRAME
2	532 15 04-06	BOLT 3/8-16
3	532 42 88-67	SCREW 5/16-18 X .750

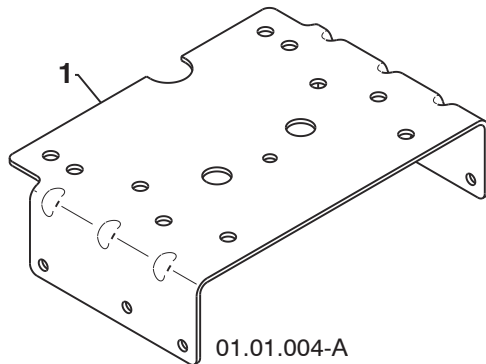

KEY NO.	PART NO.	DESCRIPTION
1	532 42 92-69	ENGINE MOUNTING PLATE

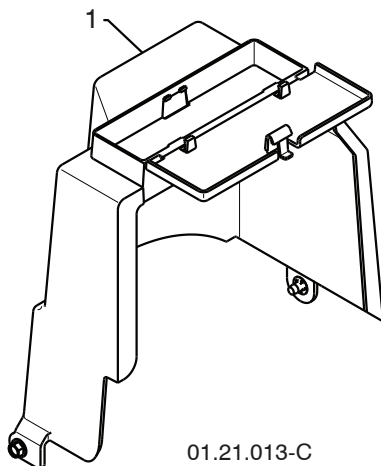

KEY NO.	PART NO.	DESCRIPTION
1	532 44 30-30	COVER ASSEMBLY

NOTE: All component dimensions given in U.S. inches. 1 inch = 25.4 mm
IMPORTANT: Use only Original Equipment Manufacturer (O.E.M.) replacement parts. Failure to do so could be hazardous, damage your snow thrower and void your warranty.

REPAIR PARTS

CHASSIS / ENGINE / PULLEYS

SNOW THROWER - MODEL NO. ST 324P (96193009101), PRODUCT NO. 961 93 00-91

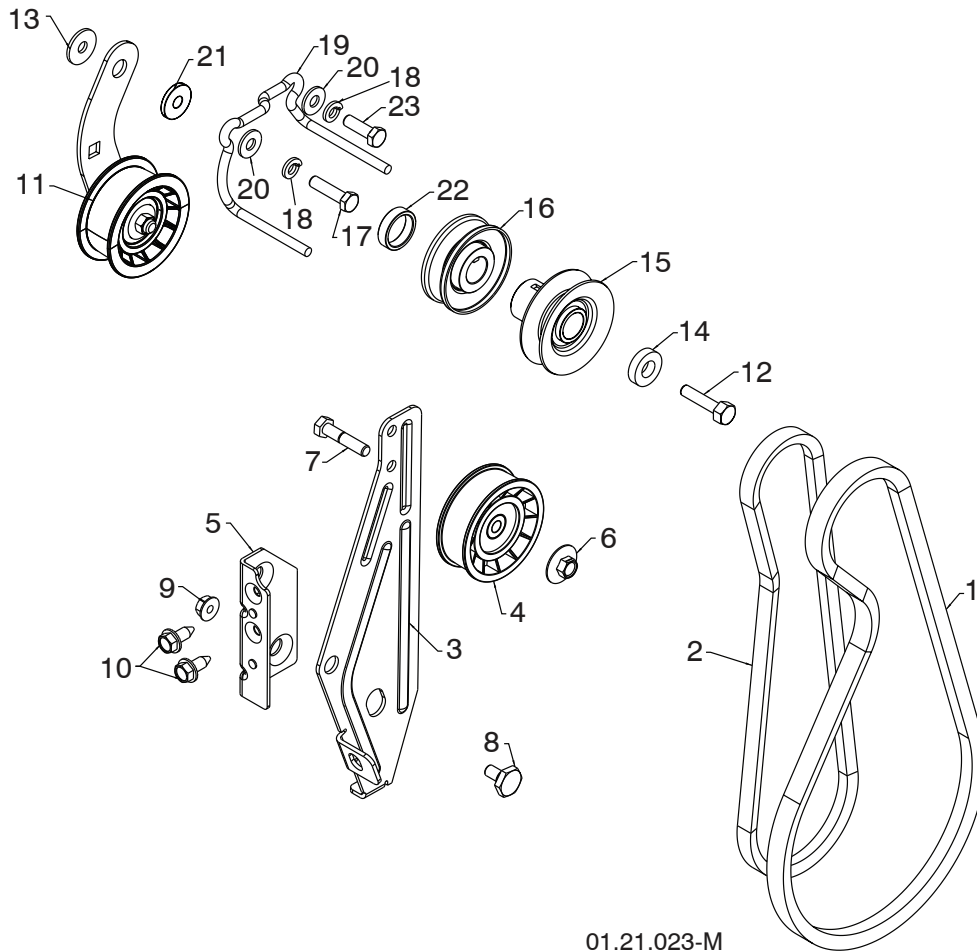

01.21.023-M

KEY NO.	PART NO.	DESCRIPTION	KEY NO.	PART NO.	DESCRIPTION
1	532 40 80-07	IMPELLER BELT	12	532 85 10-84	SCREW 3/8-24 X 1.375
2	532 44 81-83	TRACTION BELT	13	532 05 92-89	WASHER
3	584 23 24-02	IDLER ARM BRACKET	14	532 40 00-26	WASHER
4	532 18 05-23	IDLER PULLEY	15	532 42 64-91	PULLEY ENG IMPELLER
5	585 28 49-01	IDLER BRACKET	16	532 18 04-78	PULLEY ENG TRACTION
6	532 42 65-89	NUT 5/16-18	17	874 61 05-20	SCREW 5/16-24 X 1.25
7	874 78 05-24	SCREW 5/16-18 X 1.50	18	810 04 05-00	LOCKWASHER 5/16
8	532 42 42-97	SHOULDER BOLT 5/16-18 X .50	19	585 54 05-01	BELT GUIDE
9	532 75 11-53	NUT 5/16-18 LOCK	20	532 15 54-15	WASHER .20 X 8.5 X 2.0
10	817 00 05-10	SCREW 5/16-18 X 1.0 HEX WHS HD	21	532 17 53-31	IDLER BUSHING
11	585 23 84-01	TRACTION IDLER BRACKET ASM	22	532 40 94-75	SPACER
			23	874 61 05-16	SCREW 5/1-24 X 1.0 HEX

NOTE: All component dimensions given in U.S. inches. 1 inch = 25.4 mm
IMPORTANT: Use only Original Equipment Manufacturer (O.E.M.) replacement parts.
 Failure to do so could be hazardous, damage your snow thrower and void your warranty.

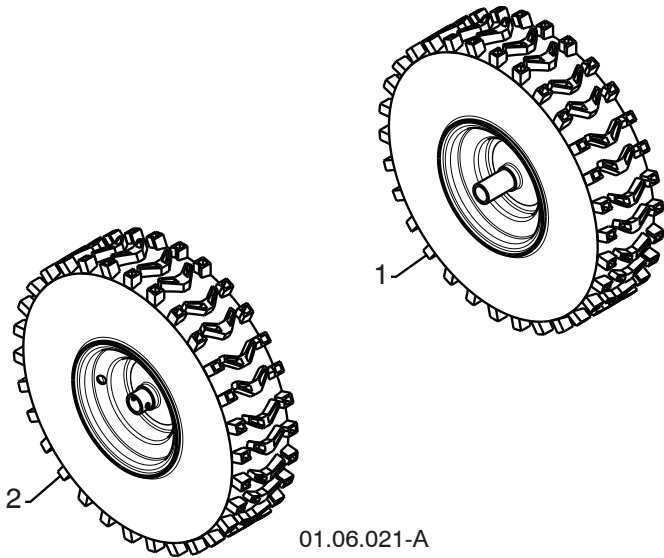

KEY NO.	PART NO.	DESCRIPTION
1	587 08 14-01	WHEEL ASSEMBLY LH
2	587 08 14-02	WHEEL ASSEMBLY RH

NOTE: All component dimensions given in U.S. inches. 1 inch = 25.4 mm
IMPORTANT: Use only Original Equipment Manufacturer (O.E.M.) replacement parts.
 Failure to do so could be hazardous, damage your snow thrower and void your warranty.

REPAIR PARTS

BAG OF PARTS

SNOW THROWER - MODEL NO. ST 324P (96193009101), PRODUCT NO. 961 93 00-91

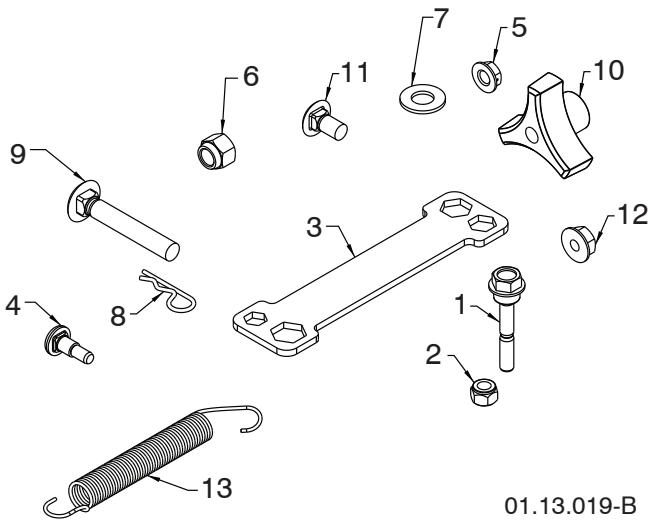

KEY NO.	PART NO.	DESCRIPTION
1	585 51 18-01	BOLT 1/4-20 X 1.81
2	873 80 04-00	NUT NYLOCK 1/4-20
3	532 42 91-12	WRENCH
4	532 17 98-29	BOLT SHOULDER
5	532 19 17-30	NUT HEX FL 1/4-20 CTR
6	873 80 06-00	NUT NYLOCK 3/8-16
7	819 13 13-16	WASHER FLAT 3/8 SAE
8	532 16 96-75	RETAINER HAIRPIN
9	872 12 06-18	BOLT 3/8-16 X 2.25
10	532 17 88-99	KNOB 3/8-16 TRI LOBE
11	585 83 20-01	BOLT BLACK 5/16-18 X 5/8
12	532 75 11-53	NUT FL LOCK 5/16-18
13	532 18 45-05	SPRING DEFLECT CHUTE
NI	532 40 97-80	SHEAR BOLT KIT

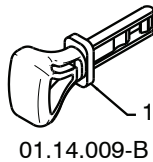

KEY NO.	PART NO.	DESCRIPTION
1	532 44 30-59	SAFETY IGNITION KEY KIT

NOTE: All component dimensions given in U.S. inches. 1 inch = 25.4 mm
IMPORTANT: Use only Original Equipment Manufacturer (O.E.M.) replacement parts. Failure to do so could be hazardous, damage your snow thrower and void your warranty.

REPAIR PARTS

BAG OF PARTS

SNOW THROWER - MODEL NO. ST 324P (96193009101), PRODUCT NO. 961 93 00-91

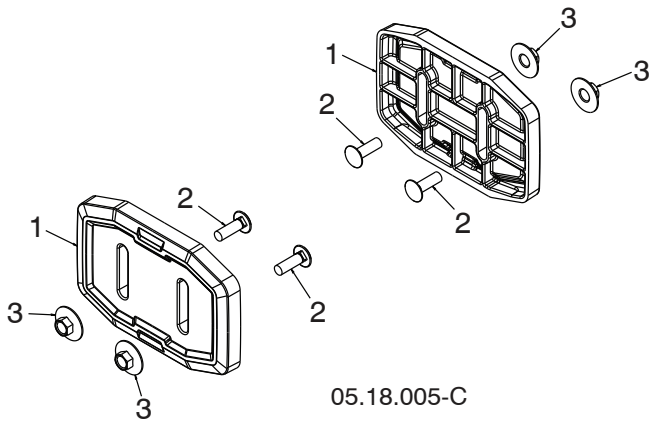

KEY NO.	PART NO.	DESCRIPTION
1	583 83 88-01	SKID PLATE UHMW
2	532 43 73-18	BOLT CARRIAGE 5/16-18 X 1.00 - BLK
3	585 80 28-01	NUT LRG FLANGE LOCK 5/16-18 - BLK

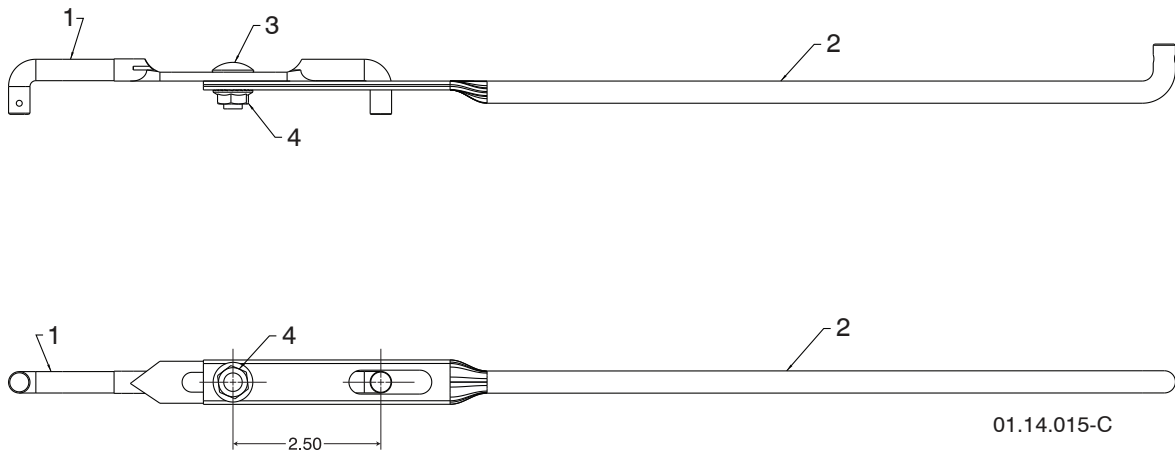

KEY NO.	PART NO.	DESCRIPTION
1	532 42 55-98	SHIFTER ROD TOP
2	532 18 77-84	SHIFTER ROD BOTTOM
3	872 27 05-05	CARRIAGE BOLT 5/16-18 X .75
4	532 15 53-77	NUT 5/16-18

NOTE: All component dimensions given in U.S. inches. 1 inch = 25.4 mm
IMPORTANT: Use only Original Equipment Manufacturer (O.E.M.) replacement parts. Failure to do so could be hazardous, damage your snow thrower and void your warranty.

SNOW THROWER - MODEL NO. ST 324P (96193009101), PRODUCT NO. 961 93 00-91

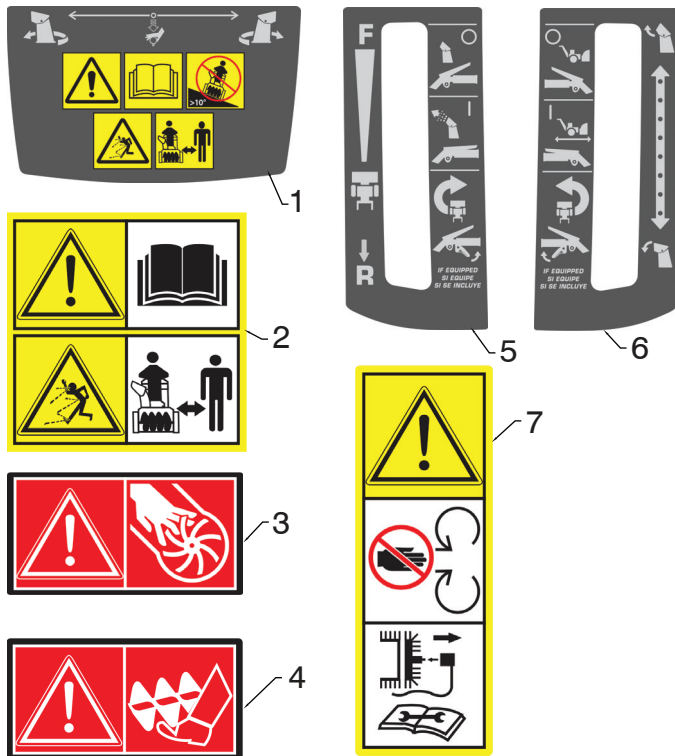

KEY NO.	PART NO.	DESCRIPTION
1	532 42 95-75	DECAL CONSOLE INSTRUCTIONS
2	532 18 40-45	DECAL AUGER
3	532 19 96-82	DECAL CHUTE
4	532 19 96-83	DECAL AUGER SAFETY
5	585 76 87-01	DECAL CONSOLE RH INSTRUCTIONS
6	585 76 87-02	DECAL CONSOLE LH INSTRUCTIONS
7	532 18 40-28	DECAL BELT GUARD

05.16.003-A

NOTE: All component dimensions given in U.S. inches. 1 inch = 25.4 mm
IMPORTANT: Use only Original Equipment Manufacturer (O.E.M.) replacement parts. Failure to do so could be hazardous, damage your snow thrower and void your warranty.

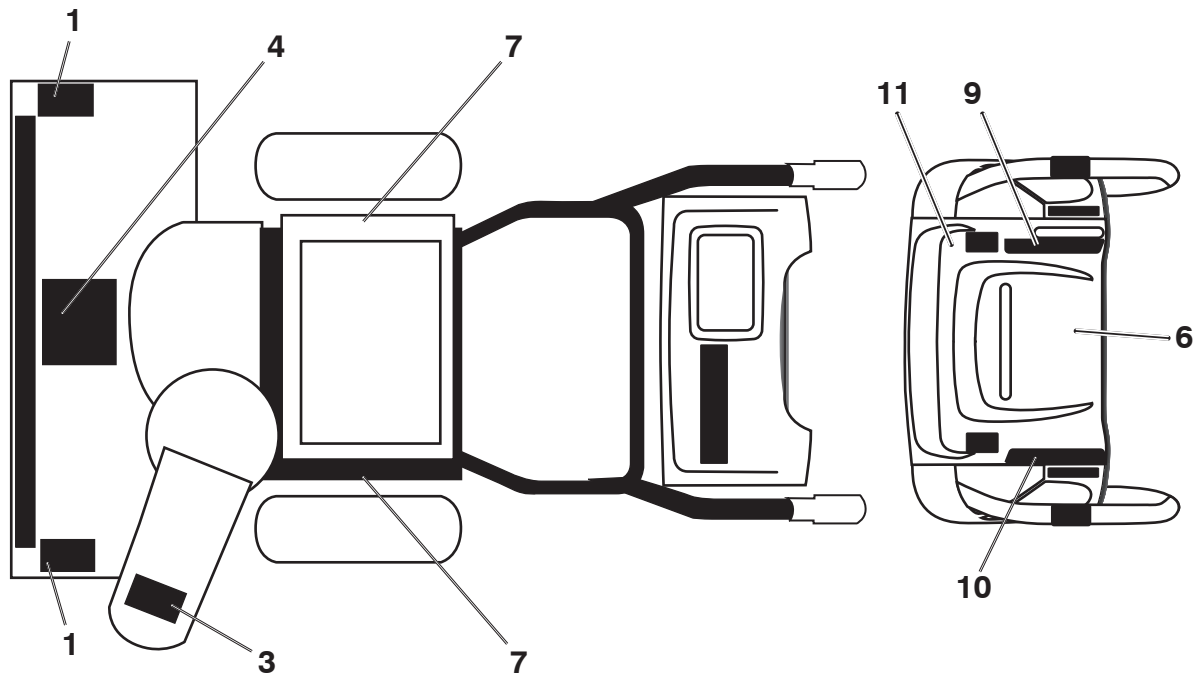

KEY NO.	PART NO.	DESCRIPTION
1	532 19 96-83	DECAL, DANGER
3	532 19 96-82	DECAL, DANGER, DEFLECTOR
4	532 18 40-45	DECAL, DANGER
6	532 42 95-75	DECAL, INSTRUCTION
7	532 18 40-28	DECAL, BELT GUARD
9	585 76 87-01	DECAL, SPEED CONTROL/TRIGGER
10	585 76 87-02	DECAL, REMOTE DEFLECTOR CONTROL/TRIGGER
11	532 44 47-68	DECAL, HANDWARMER
--	115 68 19-27	OWNER'S MANUAL, ENGLISH
--	115 68 19-46	OWNER'S MANUAL, FRENCH
--	115 68 19-31	OWNER'S MANUAL, SPANISH

NOTE: All component dimensions given in U.S. inches. 1 inch = 25.4 mm
IMPORTANT: Use only Original Equipment Manufacturer (O.E.M.) replacement parts. Failure to do so could be hazardous, damage your snow thrower and void your warranty.

SERVICE NOTES

ENGINE, LCT

COMPLETE ENGINE-585335703

GEN II 136/179/208/254cc Snow Engines

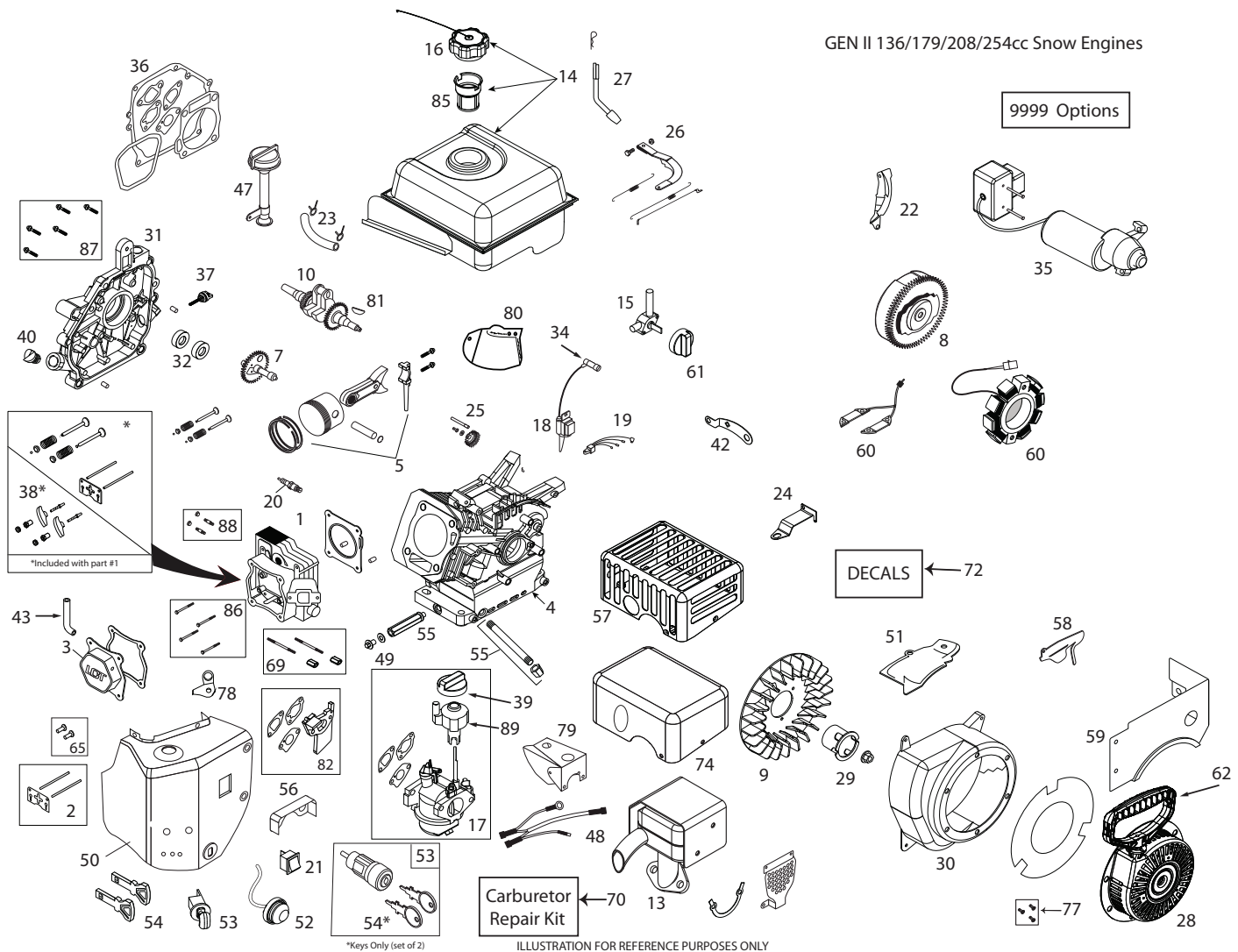

KEY PART NO. NO.

DESCRIPTION

1	585 77 14-01	CYLINDER HEAD ASSEMBLY - 254CC (INCL. GASKET)
2	585 77 15-01	PUSH ROD & PLATE KIT (254CC) (INCL. VALVE COVER GSKT)
3	585 77 16-01	VALVE COVER (254CC) (INCL. GASKET)
4	587 15 38-01	CYLINDER - 254CC (FRONT OIL DRAIN)
5	585 77 17-01	PISTON & ROD ASSEMBLY (254CC)
7	585 77 18-01	CAMSHAFT - MCR (254CC))
8	585 77 19-01	FLYWHEEL - ELECTRIC START (8-CHARGING MAGNETS) (254CC)
9	532 42 05-86	COOLLNG FAN - FLYWHEEL (PLASTIC - 208CC)

KEY PART NO. NO.

DESCRIPTION

10	587 15 39-01	CRANKSHAFT (#18 KEYED 254CC SNOW)
13	585 77 21-01	MUFFLER ASSEMBLY-GEN LL SNOW (254CC)
14	587 15 40-01	FUEL TANK (2.7L GLOSS BLACK) (254CC SNOW)(ORDER DECAL KIT SEPARATE)
15	532 42 92-34	FUEL TANK ON/OFF VALVE - GEN II SNOW
16	532 42 49-42	FUEL TANK CAP - BLACK CLLCK STYLE (VENTED)
17	587 15 41-01	CARBURETOR (L15D) (254CC SNOW W/IDLE-DOWN CONTROL) (W/GSKTS)
18	532 44 38-94	IGNITION COIL (CDI) (208/254CC) (HI-TEMP)

NOTE: All component dimensions given in U.S. inches. 1 inch = 25.4 mm
IMPORTANT: Use only Original Equipment Manufacturer (O.E.M.) replacement parts. Failure to do so could be hazardous, damage your snow thrower and void your warranty.

ENGINE, LCT

COMPLETE ENGINE-585335703

KEY PART NO.	PART NO.	DESCRIPTION	KEY PART NO.	PART NO.	DESCRIPTION
20	532 44 38-98	SPARK PLUG - PLATINUM	52	532 42 49-49	PRIMER BULB WITH HOSE-SNOW
21	532 42 49-57	ON/OFF SWITCH - ROCKER	53	532 42 49-54	KEY SWITCH - SAFETY (PUSH/PULL) SNOW (INCL. KEYS)
22	585 77 24-01	SHIELD - FLYWHEEL (ELECTRIC 208CC)	54	532 44 30-59	KEY SET - RED (2) (SNOW)
23	532 43 21-44	FUEL HOSE -1/4 (318MM CUT TO 230MM)	55	587 15 44-01	FRONT OIL DRAIN PIPE & NUT ASSY
24	585 77 25-01	SPEED CONTROL BRACKET (FIXED)(254CC SNOW)	56	585 77 33-01	CARBURETOR VAPOR SHIELD (254CCSNOW)
25	532 42 96-46	GOVERNOR GEAR ASSEMBLY (136/208CC)	58	585 77 34-01	SHIELD - GOVERNOR LINKAGE (254CC-SNOW)
26	585 77 26-01	GOVERNOR ARM & LINK KIT (254CC SNOW)	59	587 15 45-01	FUEL TANK SKIRT SHIELD (GLOSS BLACK-254CC)(ORDER DECAL KIT SEPARATE)
27	532 42 06-02	GOVERNOR ARM PADDLE	60	532 44 38-93	CHARGING COIL (60-WATT AC) (208/254CC)
28	532 43 69-67	RECOIL STARTER (ROUND STYLE-BLACK) 136/208CC GEN II SNOW	61	532 43 27-52	FUEL CONTROL KNOB (GEN II SNOW - RED)
29	532 43 69-68	STARTER CUP (USE WITH ROUND STYLE STARTER) (208CC SNOW)	62	532 44 38-99	STARTER GRIP-SNOW (DELUXE)
30	587 15 42-01	BLOWER HOUSING (GLOSS BLACK)(254CC SNOW W/FRONT DRAIN)(ORDER DECAL KIT SEPARATE)	65	581 37 28-01	TAPPET KIT (208/254CC)(SET OF 2)
31	585 77 27-01	CRANKCASE COVER (PRESS-IN TYPE HIGH OIL-FILL TUBE)	69	532 42 49-51	CARBURETOR STUDS & COUPLING KIT-SNOW
32	585 77 28-01	OIL SEAL KIT (2 PCS)	70	580 35 36-01	CARBURETOR REPAIR KIT (136/208/254CC)
34	532 43 69-66	SPARK PLUG BOOT - WITH METAL SHIELD (SNOW)	72	587 15 46-01	ARIENS 254 SNOW DECAL KIT
35	532 43 64-66	120V ELECTRIC STARTER (208/254CC GEN II) (MOUNTING BOLTS ON SIDE OF BLOCK)	74	581 76 88-01	MUFFLER HEAT SHIELD COVER (136/208/254)
36	585 77 29-01	ENGINE GASKET KIT (254CC)	77	532 43 26-88	RECOIL BOLT KIT (INCL. (3) MTG BOLTS)
38	585 77 30-01	ROCKER ARM KIT (254CC)(INCL. GASKET)	79	585 77 37-01	CARBURETOR COVER (136/208/254CC SNOW)
39	532 42 92-24	CHOKE CONTROL KNOB (GEN II RED)	80	585 77 38-01	SHIELD GOVERNOR LINK - 254CC SNOW
40	532 42 9-98	NON-REMOVABLE PLASTIC PLUG (136/208/254CC)	81	585 29 72-02	WOODRUFF FLYWHEEL KEYS (5-PACK) (5X6X18MM)
43	580 35 34-01	BREATHER TUBE (136/208/254CC)	82	585 02 05-03	CARBURETOR SPACER (208/254CC)
47	581 00 72-01	HIGH OIL-FILL TUBE/DIPSTICK (PRESS-IN TYPE) (SN >1265H0519257)	85	586 32 56-01	FUEL TANK STRAINER
48	532 42 92-62	WIRE HARNESS (208CC SNOW)	86	586 32 73-01	CYLINDER HEAD BOLT KIT (4) (136-179-208-254CC)
49	532 43 54-95	OIL DRAIN PLUG W/WASHER (136/208/254CC)	87	586 32 69-01	CC COVER BOLT KIT (6) (179-208-254CC)
50	587 15 43-01	HEATER BOX ASSEMBLY (GLOSS BLACK-254CC)(ORDER DECAL KIT SEPARATE)	88	586 32 68-01	MUFFLER MTG STUD KIT (2)
			89	587 12 48-01	SPEED CONTROL KNOB, GEN II, SNOW
			9999	587 15 48-01	HIGH ALTITUDE JET (>5,000 FEET)(254CC L15 CARBURETOR)

NOTE: All component dimensions given in U.S. inches. 1 inch = 25.4 mm
IMPORTANT: Use only Original Equipment Manufacturer (O.E.M.) replacement parts. Failure to do so could be hazardous, damage your snow thrower and void your warranty.



Consumer Wheeled Products - Limited Warranty

Husqvarna warrants to the original retail purchaser that this Husqvarna® product is **free from defects in material or workmanship** under normal use and maintenance from the date of retail purchase for the applicable Warranty Period shown on Exhibit A. This Limited Warranty may not be transferred to any subsequent purchaser of this Husqvarna® product. Certain components (e.g., engines and transmissions) are excluded from coverage, and other limitations apply, as described in this document. Husqvarna will repair or replace at its discretion, any defective product or part covered by the Limited Warranty, free of charge at any authorized Husqvarna Servicing Dealer/Center using original OEM Husqvarna replacement parts, subject to the limitations and exclusions described below. Husqvarna does not offer an over-the-counter exchange program.

DISCLAIMERS, LIMITATIONS AND EXCLUSIONS

1. **WARRANTY DISCLAIMER.** THIS LIMITED WARRANTY IS THE SOLE EXPRESS WARRANTY PROVIDED BY HUSQVARNA AND THERE ARE NO WARRANTIES WHICH EXTEND BEYOND THE DESCRIPTION ON THE FACE HEREOF, EXCEPT AS MAY BE PROVIDED BY LAW. THIS WARRANTY IS GIVEN **ONLY** BY HUSQVARNA, AND MAY BE MODIFIED ONLY BY HUSQVARNA. THIS LIMITED WARRANTY IS THE FINAL EXPRESSION OF OUR AGREEMENT, AND IS A COMPLETE AND EXCLUSIVE STATEMENT OF THE TERMS OF THAT AGREEMENT. THIS LIMITED WARRANTY GIVES YOU SPECIFIC LEGAL RIGHTS, AND YOU MAY ALSO HAVE OTHER RIGHTS WHICH VARY BASED ON LOCALITY

2. **LIMITED DURATION.** ANY WARRANTY THAT MAY BE IMPLIED BY LAW (INCLUDING ANY IMPLIED WARRANTY OF FITNESS FOR A PARTICULAR PURPOSE OR USE AND IMPLIED WARRANTY OF MERCHANTABILITY) IS LIMITED TO THE DURATION OF THE APPLICABLE WARRANTY PERIOD UNDER THIS LIMITED WARRANTY. SOME LOCALITIES DO NOT ALLOW LIMITATIONS ON HOW LONG AN IMPLIED WARRANTY LASTS, SO THE ABOVE LIMITATIONS MAY NOT APPLY TO YOU.

3. **EXCLUSIVE REMEDIES.** SOME LOCALITIES, INCLUDING THE PROVINCE OF QUEBEC, DO NOT ALLOW THE EXCLUSION OR LIMITATION OF LIABILITY FOR INJURY TO PERSON OR FOR DAMAGES RESULTING FROM THE FAULT OF THE MANUFACTURER AND/OR THE EXCLUSION OR LIMITATION OF INCIDENTAL OR CONSEQUENTIAL DAMAGES. AS SUCH, SOME OF THE FOLLOWING LIMITATIONS MAY NOT APPLY TO YOU. THE ABOVE REMEDIES ARE THE EXCLUSIVE REMEDIES FOR ANY BREACH OF THIS LIMITED WARRANTY. NO OTHER REMEDY, INCLUDING, BUT NOT LIMITED TO ANY SPECIAL, INCIDENTAL, INDIRECT OR CONSEQUENTIAL DAMAGES, FOR LOST PROFITS, LOST SALES, INJURY TO PERSON OR PROPERTY, OR ANY OTHER INCIDENTAL OR CONSEQUENTIAL LOSS SHALL BE AVAILABLE, AND ALL SUCH DAMAGES ARE HEREBY DISCLAIMED.

4. **Engines, Transmissions and certain other components are NOT covered.** This Limited Warranty does not cover any of the following:

(a) *Engines and Attachments.* Except where otherwise indicated on Exhibit A, all Engines and Attachments are not covered by this Limited Warranty. In most cases, these items are NOT manufactured by Husqvarna in which case they may be covered separately by their respective manufacturer's warranties if one is provided and included with the product at the time of purchase. All such claims must be submitted and sent to the appropriate manufacturer or as otherwise directed in those separate warranties. Husqvarna is not authorized to handle warranty adjustments or repairs on engines manufactured by Briggs & Stratton, Honda, Kawasaki, or Kohler (Husqvarna does handle warranty issues on engines manufactured by Liquid Combustion Technologies (LCT). Husqvarna does not assume any warranty obligation of the other manufacturers' engines under this Limited Warranty.

(b) *Transmissions.* Except where otherwise indicated on Exhibit A, Transmission / Transaxle (including Drive Systems) are not covered by this Limited Warranty. In most cases, these items are NOT manufactured by Husqvarna in which case they may be covered separately by their respective manufacturer's warranties if one is provided and included with the product at the time of purchase. The following transmission / transaxle manufacturers, Dana, Hydro-Gear, Tuff-Torq provide a warranty for the transmission / transaxle to the ultimate purchaser or to Husqvarna. Husqvarna will assign the transmission / transaxle manufacturer's warranty or any rights thereof to the original purchaser of the unit. To obtain transmission / transaxle warranty service, first contact the retailer who you purchased the unit from. Should you require assistance or have any questions concerning transmission / transaxle warranty coverage, contact Husqvarna directly at our website www.husqvarna.com or call 800-487-5951 (US) or 800-805-5523 (Canada) for an authorized Husqvarna service provider. All such claims must be submitted and sent to the appropriate manufacturer or as otherwise directed in those separate warranties. Husqvarna is not authorized to handle warranty adjustments or repairs on transmissions or transaxles. Husqvarna does not assume any obligations under this Limited Warranty for the above listed manufacturers (for exceptions - see Exhibit A).

(c) *Expendable Parts.* This Limited Warranty does not cover general maintenance parts and items ("Expendable Parts"), including without limitation spark plugs, bulbs, filters, lubricants, starter cords, belts, blades, and blade adapters.

(d) *Emissions Control Components.* This Limited Warranty does not cover Emissions control equipment and components to the extent regulated by the U.S. Environmental Protection Agency or similar state, provincial or federal agencies. Such equipment and components are covered by a separate emission control warranty statement supplied with your new product. Please consult this separate warranty statement for details.

5. **Any COMMERCIAL, INSTITUTIONAL, AGRICULTURAL, INDUSTRIAL, INCOME PRODUCING, or RENTAL use will result in either No Warranty or a Shortened Warranty Period.** Depending on the product, there is either NO WARRANTY (whether statutory, contractual or otherwise) or a reduced warranty if the product is used for commercial, institutional, agricultural, industrial, income producing, or rental purposes and, in such circumstances, this Limited Warranty is offered instead of and replaces any warranty regime provided for by law. Please refer to Exhibit A.

6. **Reconditioned or Refurbished Products have a 30 Day Limited Warranty.** Under this Limited Warranty, Certified Factory Reconditioned or Refurbished products have a 30 Day Limited Warranty for parts and labor for Non-Commercial Use. Products are only reconditioned at the Husqvarna Factory.

7. **Owner's (Your) Responsibilities.** To preserve your rights under this Limited Warranty, you must exercise reasonable care and use of the product, including, following the preventative maintenance, storage, fuel and oil usages as prescribed in the enclosed operator's manual. For example, the following items are the Owner's responsibility and are **not** covered by this Limited Warranty:

- a. Set-up and pre-delivery service, and engine tune-ups;
- b. Adjustments after the first (30) thirty days of purchase and beyond, such as throttle cable, belt guides adjustments; and
- c. Preventative maintenance as outlined in the operator's manual.

In addition, you must cease using the product immediately upon any failure or damage. The product should be taken to an authorized Husqvarna servicing dealer prior to any further use.

8. **Damages resulting from normal aging, wear and tear or neglect are NOT covered.** The Limited Warranty does not cover damage other than that resulting from defects in material or workmanship. The following are NOT considered defects in material or workmanship, and therefore are NOT covered.

- (a) Abrasion to mower decks;
- (b) Tires damaged by external punctures;
- (c) Natural discoloration of materials due to ultraviolet light;
- (d) Damage to cutting equipment by way of contact with, rocks, or other non-approved materials and/or structures;

In addition, this Limited Warranty does not cover damages, malfunctions or failures resulting from abuse or neglect of the product related to or including any of the following:

- (e) Failure to provide or perform required maintenance services as prescribed in the operator's manual;
- (f) Abuse, misuse, neglect, modifications, alterations, normal wear, improper servicing, use of unauthorized attachments, Lack of lubrication or engine failure, due to the use of oils that do not meet Engine manufacturer's specifications;
- (g) Use of gasohol (fuel containing ethanol), containing methanol (fuel containing wood alcohol). Ethanol fuel E15 or E85 **is NOT** approved for use in Husqvarna products. Using E15 or E85 fuel will cause major engine damage which **is NOT** covered by this Husqvarna warranty. NOTE: Gasohol (fuel containing ethanol), which contains a maximum 10% ethanol (grain alcohol) is approved. The prescribed mixing ratio of gasoline to oil is 50:1 and is listed in the Husqvarna oil label and covered in your operator's manual.
- (h) Use of ether or any starting fluids;
- (i) Pressure cleaning or steam cleaning the product;
- (j) Use of spark plugs other than those meeting emission performance requirements listed in the operator's manual;
- (k) Tampering with engine speed governor or emission components, or running engines above specified and recommended engine speeds as listed in your operator's manual;
- (l) Operation of the unit with improperly installed/removed or modified cutting shields, guards, or safety devices;
- (m) Any removed/damaged air filter, excessive dirt, abrasives, salt water, moisture, corrosion, rust, varnish, stale fuel, or any adverse reaction due to incorrect storage procedures;
- (n) Failures due to improper set up, pre-delivery service or repair service by anyone other than an authorized Husqvarna servicing dealer during the warranty period;
- (o) Dirt contaminated grease or oil, use of incorrect type of greases or oils, failure to comply with recommended greasing intervals, water or moisture damage, and/or improper storage;
- (p) Sprayers pumping or spraying caustic or flammable materials, lack of or broken strainers; or
- (q) Continued use of product, after initial operational problem or failure occurs.

9. **Reinforced Stamped (Armor Protected) 10 Year Limited & Fabricated Limited Lifetime, Deck Warranties.** These Limited Warranties are for the deck shell only – mechanical components/parts such as belts, pulleys, spindle housings, bearings, blades, rods, height adjusters, caster/anti scalp wheels etc... are NOT covered. The Limited Lifetime Warranty does not cover damage other than that resulting from defects in material or workmanship. The following are NOT considered defects in material or workmanship, and therefore are NOT covered:

- (a) Abrasion to mower decks, including sand wear;
- (b) Damage to cutting equipment by way of contact with, rocks, or other non-approved materials and/or structures;
- (c) Rust and corrosion; and
- (d) Natural discoloration of paint or other materials due to ultraviolet light.

HOW TO OBTAIN SERVICE

10. **Authorized Husqvarna Servicing Dealer/Center.** In order to obtain warranty coverage it is your responsibility (at your expense) to deliver or ship your Husqvarna unit to an authorized Husqvarna Servicing Dealer/Center and arrange for pick-up or return of your unit after the repairs have been made. If you do not know the location of your nearest authorized Husqvarna Servicing Dealer, call Husqvarna, at 1-800-487-5951 during the hours of 8:00 AM to 8:00 PM Eastern Standard Time, or visit www.husqvarna.com. Should you require assistance or have questions concerning this Limited Warranty, you may contact us at 800-487-5951 (US) or 800-805-5523 (Canada) during the hours of 8:00 AM to 8:00 PM Eastern Standard Time or contact us through the web at www.husqvarna.com.

11. **Documentation Required.** You must maintain and present Proof of purchase (including date, product model and, if applicable, engine serial number) to an authorized Husqvarna Servicing Dealer for warranty service under this Limited Warranty. Proof of purchase rests solely with you. Husqvarna encourages you to register your product online at www.usa.husqvarna.com (US & Canada) to help ensure, among other things, that you can be notified of important product information. However, registering your product is not a condition of warranty service.

Husqvarna Professional Products, NA, Inc.
9335 Harris Corners Parkway, Suite 500, Charlotte, NC28269

575 49 43-01 W 2013 IR

Consumer Wheeled Limited Warranty Chart 2013

Exhibit A

Product/Component	Consumer (personal, household use only)	Commercial (any commercial, professional, institutional, agricultural, or income producing use, other than Rental Use)	Rental (any rental usage)
Riding Lawn Tractors:			
Frame, Chassis, Front Axle	5 Years	No Warranty	No Warranty
Engine*	*	*	*
Transmission (if made by Husqvarna/Peerless)	3 Years	No Warranty	No Warranty
Transmission (if third party)**	**	**	**
XLS Models only - stamped deck shell. Armor Protected Limited Warranty	10 Years	No Warranty	No Warranty
Fabricated Deck shell. Limited Lifetime Warranty	***	No Warranty	No Warranty
Battery	1 Year Pro-rated	No Warranty	No Warranty
Other Non-Expendable Components	3 Years	No Warranty	No Warranty
Residential Zero Turn Mowers (RZ Only)			
Engine*	*	*	*
Transmission **	**	No Warranty	No Warranty
RZ4623 (967009801 & 967009802) RZ5426 (967003601 & 967003602) - stamped deck shell. Armor Protected Limited Warranty	10 Years	No Warranty	No Warranty
Fabricated Deck shell. Limited Lifetime Warranty	***	No Warranty	No Warranty
Battery	1 Year Pro-rated	No Warranty	No Warranty
Other Non-Expendable Components	3 Years	No Warranty	No Warranty
Residential Zero Turn Mowers (EZ, MZ, M-ZT)			
Engine*	*	*	*
Transmission** (EZ & MZ Zero Turn)	2 Years **	1 Year **	90 days
Transmission** (M-ZT Zero Turn)	2 Years **	2 Years **	90 days
MZ5424S, MZ5425S, MZ5424SR, stamped deck shell. Armor Protected Limited Warranty. Product # 967003902, 967003903, & 25021.	10 Years	No Warranty	No Warranty
Fabricated Deck shell. Limited Lifetime Warranty	***	No Warranty	No Warranty
Battery	1 Year Pro-rated	1 Year Pro-rated	No Warranty
Other Non-Expendable Components	3 Years	1 Year	No Warranty
Snow Throwers, Tillers, LE475 Edger			
Engine*	*	*	*
Auger Gearbox	5 Years	90 days	90 days
Other Non-Expendable Components	3 Years	90 days	90 days
Tiller Tines	***	No Warranty	No Warranty
Walk Behind Mowers, High Wheel Trimmer			
Engine*	*	*	*
Battery	1 Year Pro-rated	No Warranty	No Warranty
Other Non-Expendable Components	3 Years	No Warranty	No Warranty
Hovering Trimmers			
Engine*	*	*	*
Other Non-Expendable Components	2 Years	1 Year	90 days
Front Mounted Deck Riders (120S, 220T, 322T)			
Frame, Chassis, Front Axle	3 Years	No Warranty	No Warranty
Engine*	*	*	*
Transmission	**	No Warranty	No Warranty
Battery	1 Year Pro-rated	No Warranty	No Warranty
Other Non-Expendable Components	3 Years	No Warranty	No Warranty
Cultivators			
Battery	1 Year Pro-rated	No Warranty	No Warranty
Other Non-Expendable Components	2 Years	No Warranty	No Warranty
Spreaders			
Spreader	1 Year	1 Year	1 Year
Robotic Mowers			
Robotic Mower	2 Years	90 days	90 days
Battery	1 Year	1 Year	1 Year
	Consumer	Commercial	Rental

Consumer Wheeled Limited Warranty Chart 2013

Exhibit A

Product/Component	Consumer (personal, household use only)	Commercial (any commercial, professional, institutional, agricultural, or income producing use, other than Rental Use)	Rental (any rental usage)
Parts & Accessories (if purchased)			
Accessories (e.g., grass catcher, bumper guard accessories, etc.)	1 Year	No Warranty	No Warranty
Parts (e.g., belts, blades, etc.)	90 days	No Warranty	No Warranty
Parts & Accessories (if replaced in Warranty Service)			
Replacement parts and/or accessories provided under this Limited Warranty are warranted only for the BALANCE of the warranty period applicable to the part or accessory that was replaced.	See to left Consumer	See to left Commercial	See to left Rental

* See Separate Engine Manufacturer's or Manufacturer's warranty. LCT Engines on specific Snow Throwers & Tillers, warranty through Husqvarna.

** See reference 4 (b) of the warranty statement.

RZ - Two (2) Year Consumer warranty, parts & labor, with Hydro-Gear Distributor network.

EZ - One (1) Year Commercial warranty, parts & labor, with Husqvarna.

Two (2) Year Consumer warranty, parts & labor, with Hydro-Gear Distributor network.

MZ - (ZT3100 Transmission) One (1) Year Commercial warranty, parts & labor, with Hydro-Gear Distributor network.

(ZT3100 Transmission) Two (2) Years Consumer warranty, parts & labor, with Hydro-Gear Distributor network.

M-ZT - (ZT3400 transmission) Two (2) Year warranty, parts & labor, with Hydro-Gear Distributor network.

*** "Limited Lifetime Warranty" on Tiller tines and Fabricated Deck shell is for the life of the product or 7 (seven) years after the last date of the complete unit's final production, whichever comes first. Deck Shell replacement will be limited to a maximum of two (2) decks within the Limited Lifetime Warranty.

Armor Protected Stamped Deck Shell Example Below

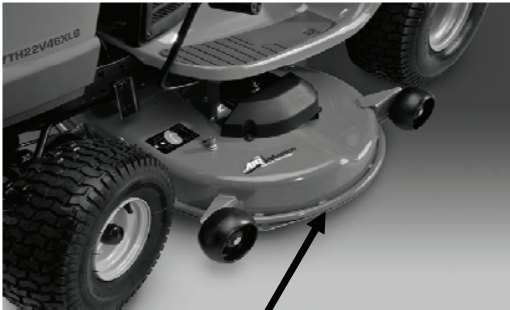

Armor Protected Stamped Deck Shell Reinforced area

Fabricated Deck Shell Example Below



Stamped Deck Shell below, NOT reinforced

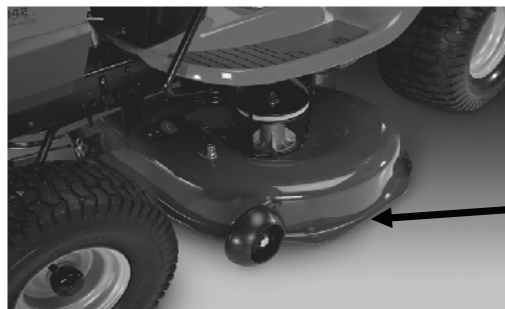

No reinforced area

06/12/2014 TH