

Repair Parts Manual

YTH2648TDRF / 96041026403



English

587 23 15-27 Rev. 7



Please read the operator's manual carefully and make sure you understand the instructions before using the machine.

HOW TO USE THIS MANUAL

This manual is designed to provide the customer with a means to identify the parts on his/her tractor when ordering repair parts. The illustrations may or may not represent the actual assemblies; therefore, it is not recommended to use this manual as a guide to assemble or disassemble the tractor. Some hardware and parts are drawn larger in order to more readily identify them.

Each tractor has its own model number.

The model number for your tractor can be found on the fender under the seat.

When ordering parts, always give the following information:

- Product - "Lawn Tractor"
- Model Number - "YTH2648TDRF" (96041026403)
- Part Number
- Part Description

TABLE OF CONTENTS

SCHEMATIC	3
ELECTRICAL.....	4-5
CHASSIS AND ENCLOSURES.....	6-7
DRIVE.....	8-9
ENGINE.....	10-11
STEERING WHEEL	12-13
MOWER DECK	14-15
MOWER LIFT.....	16
SEAT	17
DECALS	18

TRACTOR - MODEL NO. YTH2648TDRF (96041026403), PROD. NO. 960 41 02-64 SCHEMATIC

SCH12

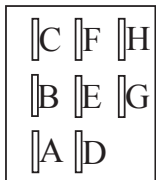
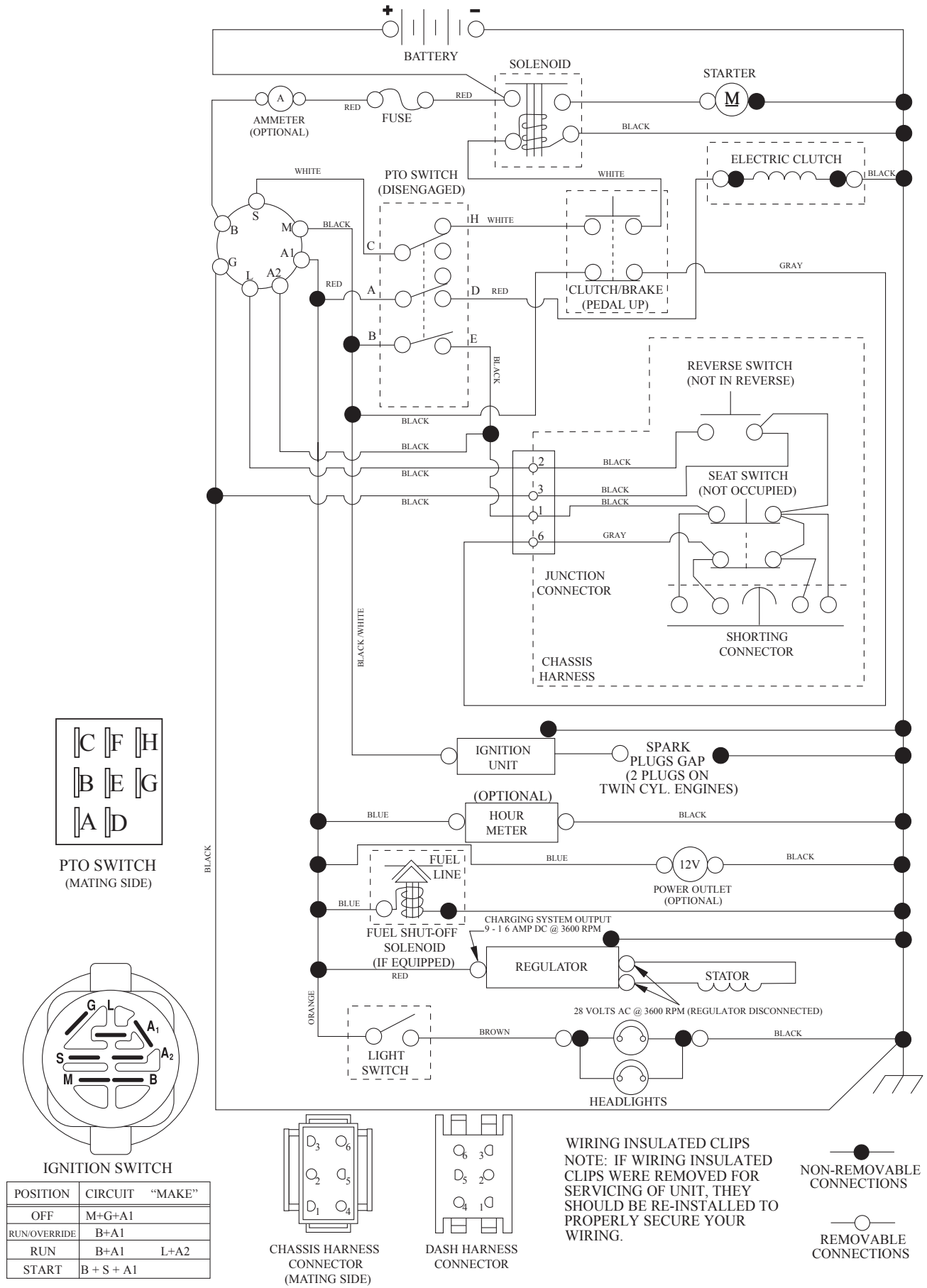

PTO SWITCH
(MATING SIDE)

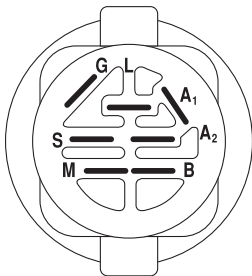

IGNITION SWITCH

POSITION	CIRCUIT	"MAKE"
OFF	M+G+A1	
RUN/OVERRIDE	B+A1	
RUN	B+A1	L+A2
START	B+S+A1	

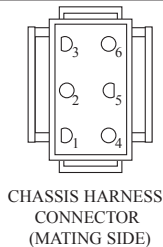

CHASSIS HARNESS
CONNECTOR
(MATING SIDE)

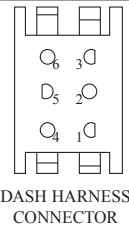

DASH HARNESS
CONNECTOR

WIRING INSULATED CLIPS
NOTE: IF WIRING INSULATED
CLIPS WERE REMOVED FOR
SERVICING OF UNIT, THEY
SHOULD BE RE-INSTALLED TO
PROPERLY SECURE YOUR
WIRING.

●
NON-REMOVABLE
CONNECTIONS

○
REMOVABLE
CONNECTIONS

**TRACTOR - MODEL NO. YTH2648TDRF (96041026403), PROD. NO. 960 41 02-64
ELECTRICAL**

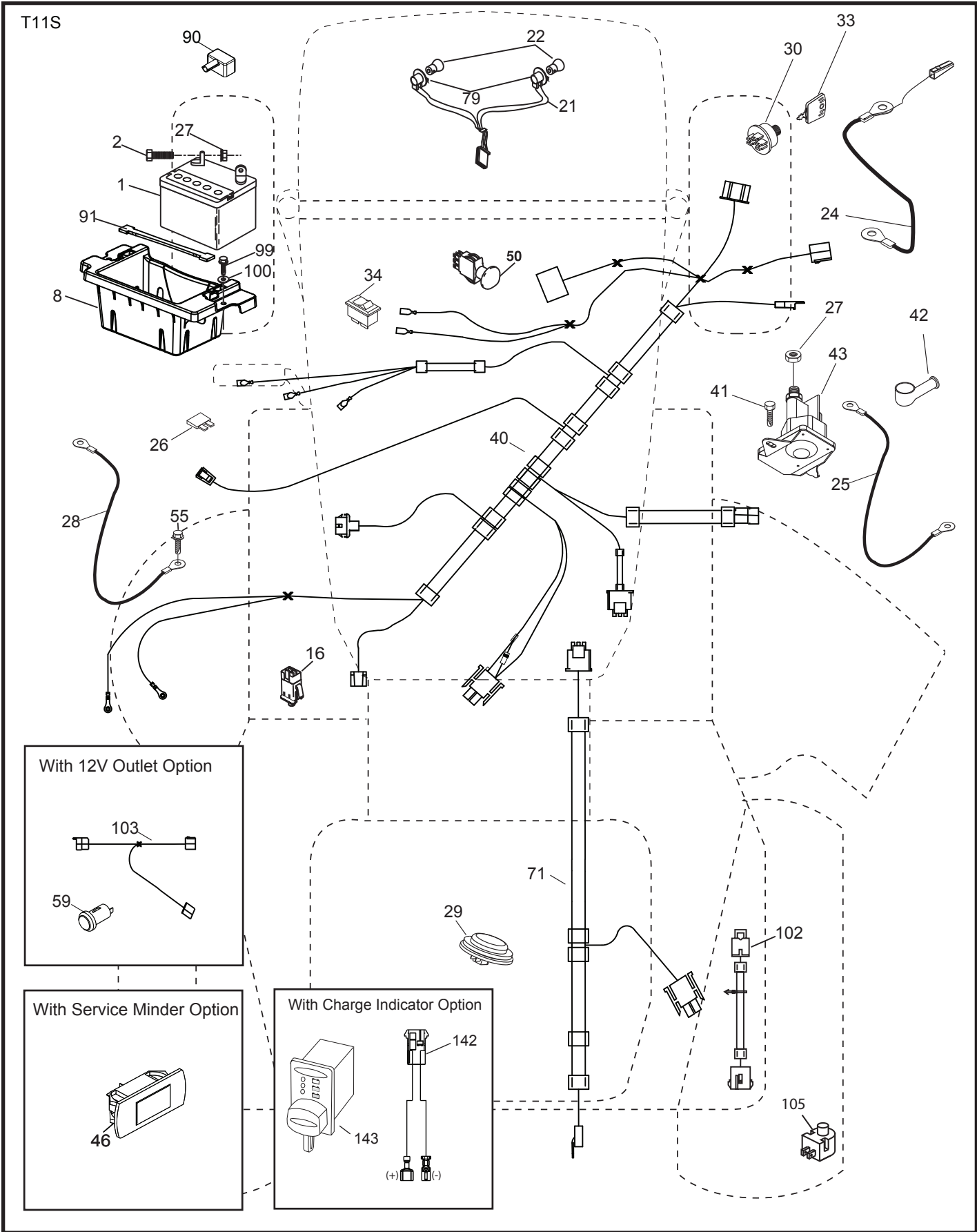

**TRACTOR - MODEL NO. YTH2648TDRF (96041026403), PROD. NO. 960 41 02-64
ELECTRICAL**

KEY NO.	PART NO.	DESCRIPTION
1	532 16 34-65	Battery
2	874 76 04-12	Bolt Hex Hd. 1/4-20 unc x 3/4
8	532 18 64-91	Battery Box
16	532 17 61-38	Switch Interlock
21	532 40 02-52	Harness Socket Light
22	532 00 41-52	Bulb, Light # 1156
24	585 55 56-01	Cable Battery
25	585 55 55-01	Cable Starter
26	532 17 51-58	Fuse
27	873 51 04-00	Nut Keps Hex 1/4-20 unc
28	532 41 65-88	Cable Ground 21" Blk. 6 Ga.
29	532 40 15-45	Switch Seat
30	532 19 33-50	Switch Ign.
33	532 41 19-33	Key/Chain
34	532 11 07-12	Switch Light/Reset
40	581 02 27-01	Harness Ignition Dash
41	817 72 04-08	Screw Thd. Cut 1/4-20 x 1/2
42	532 13 15-63	Cover Terminal Red
43	532 19 25-07	Solenoid
46	586 16 18-01	Gauge Hourmeter
50	532 17 46-51	Switch PTO
55	817 06 05-12	Screw Thdrol. 5/16-18 x 3/4
59	532 40 03-03	Outlet 12-Volt
71	532 19 42-76	Harness Chassis
79	532 17 52-42	Socket Asm. Bulb
90	532 43 53-95	Cover Terminal Battery
91	532 19 02-70	Strap Battery
99	817 67 04-12	Screw Hex Wsh. Thdrol. 1/4-20 x 3/4
100	819 09 14-16	Washer 9/32 x 7/8 x 16 Ga.
102	532 40 44-54	Harness Pigtail
103	532 40 79-62	Harness Pigtail 12V Outlet
105	532 40 75-68	Switch Reverse
142	583 85 78-01	Harness Charge Port
143	532 44 80-59	Charge Port

NOTE: All component dimensions given in U.S. inches
1 inch = 25.4 mm

**TRACTOR - MODEL NO. YTH2648TDRF (96041026403), PROD. NO. 960 41 02-64
CHASSIS**

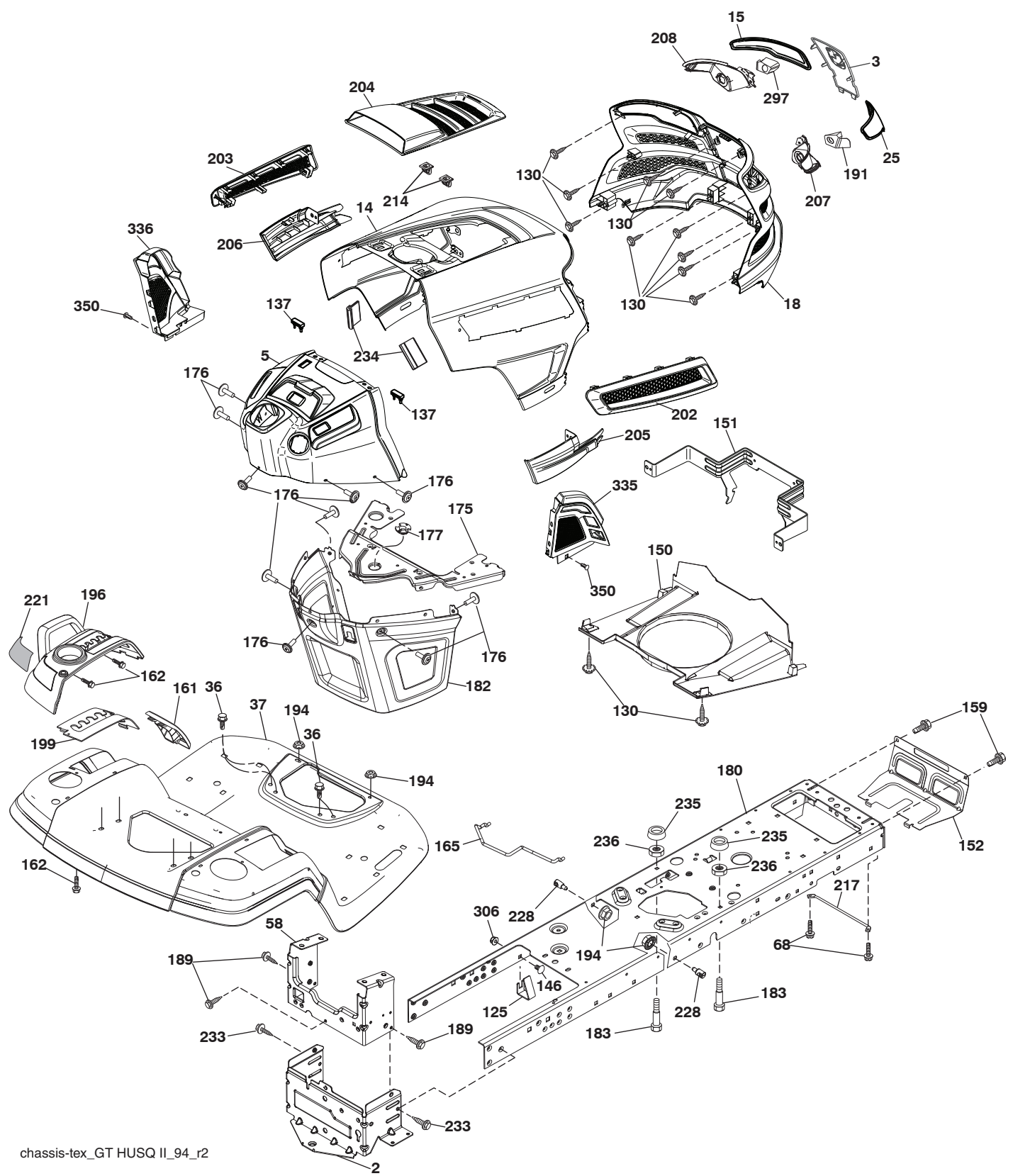

chassis-tex_GT HUSQ II_94_r2

**TRACTOR - MODEL NO. YTH2648TDRF (96041026403), PROD. NO. 960 41 02-64
CHASSIS**

KEY NO.	PART NO.	DESCRIPTION	KEY NO.	PART NO.	DESCRIPTION
2	532 41 22-82	Drawbar Lower	194	873 90 05-00	Nut Lock Hex Flange 5/16-18
3	532 44 44-81	Applique	196	532 43 96-74	Console Asm. Deck Lift
5	532 43 74-86	Dash	199	532 19 82-59	Plate Deck Lift
14	532 44 11-77	Hood	202	532 43 97-28	Vent Side Hood RH
15	532 43 97-33	Lens LH	203	532 43 97-27	Vent Side Hood LH
18	532 44 06-53	Grille Asm.	204	532 43 57-14	Vent Top Hood
25	532 44 33-85	Lens RH	205	532 43 97-30	Skirt Hood Side RH
36	817 06 05-12	Screw 5/16-18 x 3/4	206	532 43 97-29	Skirt Hood Side LH
37	532 44 12-08	Fender	207	532 43 97-34	Bezel RH
58	532 41 22-81	Drawbar Upper	208	532 43 97-35	Bezel LH
68	817 49 05-08	Screw 5/16-18 x 1/2	214	532 19 91-45	Clip Retainer Tinner
125	581 68 48-01	Clip Fuel Line	217	532 40 91-67	Rod Pivot
130	532 41 63-58	Screw #10 x 0.750 BOS Thread	221	532 19 89-09	Reflector LH
137	532 40 75-90	Bumper Dash	228	532 19 51-61	Stud Fastner
146	581 85 79-01	Bolt	233	532 19 65-39	Bolt Shoulder
150	532 43 97-74	Air Duct	234	532 40 47-42	Bumper Hood
151	532 43 66-70	Bracket Pivot	235	532 40 61-29	Spacer Fender
152	532 43 98-70	Shield Browning	236	873 93 05-00	Nut Lock 5/16-18 unc
159	817 00 06-12	Screw Hexwsh THDR 3/8 - 16x3/4	297	532 43 74-56	Insert LH
161	532 43 99-29	Window Fuel	306	873 90 06-00	Nut Lock
162	532 14 24-32	Screw	335	532 44 82-04	Cover Dash RH
165	532 19 43-30	Support Tank Rear	336	532 44 53-09	Cover Dash LH
175	532 19 63-04	Crossmember	350	532 44 51-43	Clip X-mas Tree
176	532 40 07-76	Screw 10-24 x 5/8	--	532 43 18-82	Kit Guard Brush
177	532 19 52-27	Bushing Steering			
180	532 44 55-59	Chassis			
182	532 40 68-59	Dash Lower			
183	874 52 05-20	Bolt 5/16-18 x 1-1/4 Full Thread			
189	817 00 05-12	Screw 5/16-18 x 3/4			
191	532 43 74-55	Insert RH			

NOTE: All component dimensions given in U.S. inches
1 inch = 25.4 mm

**TRACTOR - MODEL NO. YTH2648TDRF (96041026403), PROD. NO. 960 41 02-64
DRIVE**

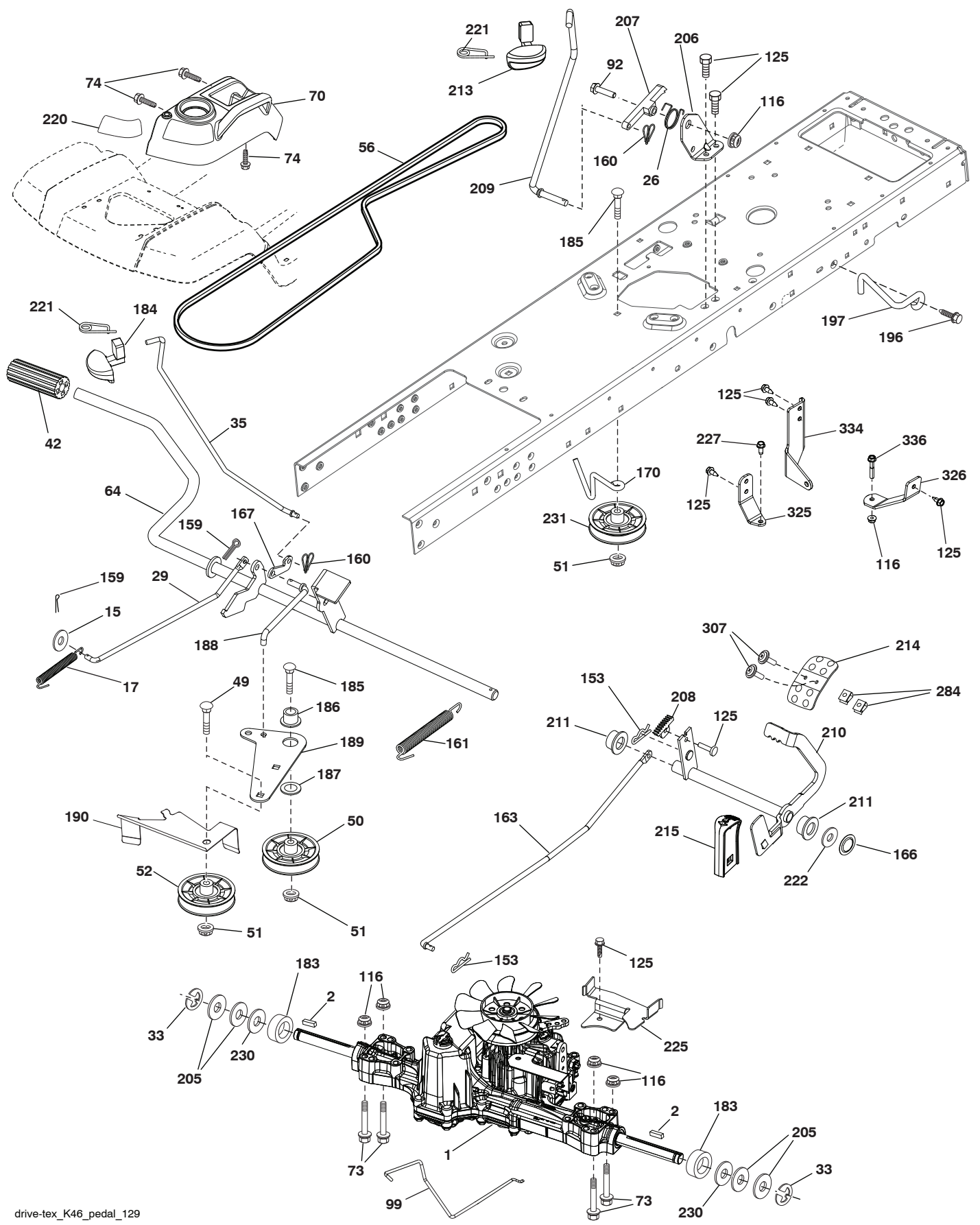

drive-tex_K46_pedal_129

TRACTOR - MODEL NO. YTH2648TDRF (96041026403), PROD. NO. 960 41 02-64 DRIVE

KEY NO.	PART NO.	DESCRIPTION	KEY NO.	PART NO.	DESCRIPTION
1	---	Transaxle, TUFFTORQ K46LD (426121) (Order parts from transaxle manufacturer.)	187	819 13 32-10	Washer
2	532 12 35-83	Key	188	532 19 43-23	Link Clutch Ground Drive
15	819 13 13-16	Washer 13/32 x 13/16 x 16 Ga.	189	532 19 43-17	Bellcrank Ground Drive
17	532 41 36-78	Spring, Brake	190	532 19 43-18	Keeper Bellcrank Ground Drive
26	532 19 96-79	Spring Return Cruise	196	817 00 06-16	Screw 3/8-16 x 1
29	532 40 38-06	Rod, Brake	197	532 19 58-04	Bracket Clutch Anti-Rotation
33	812 00 00-01	Ring E	205	532 12 17-48	Washer
35	583 86 45-01	Rod, Brake, Park	206	532 44 85-96	Bracket Mount Latch Cruise
42	532 12 48-72	Cover, Foot Pedal	207	532 19 78-68	Latch Control Cruise
49	872 11 06-14	Bolt	208	532 19 78-69	Gear Sector Control Cruise
50	532 19 43-27	Pulley Idler Flat	209	532 19 95-92	Rod Control Cruise
51	873 90 06-00	Lock Nut 3/8-16	210	532 19 78-60	Rocker Asm. Pedal Control
52	532 19 43-26	Idler V-Groove	211	532 12 01-83	Bearing Nylon
56	532 13 09-69	V-Belt, Drive	213	532 40 31-19	Knob Control Cruise
64	532 19 78-65	Shaft Asm. Pedal Brake Control	214	532 41 68-63	Pedal Forward
70	532 43 96-61	Console Shift	215	532 40 17-23	Pedal Reverse
73	874 49 05-40	Bolt Hex Flghd 5/16-18 Gr. 5	220	532 19 89-08	Reflector RH
74	532 14 24-32	Screw Hex Wsh. Hi-Lo 1/4 x 1/2 unc	221	532 40 31-87	Retainer Spring Clip Handle
92	874 76 05-20	Bolt Fin Hex 5/16-18 unc x 1.25	222	879 21 20-10	Washer 21/32 x 1-1/4 x 10 Ga.
99	532 41 57-42	Rod Spring Bypass	225	532 40 33-19	Keeper Belt Trans.
116	873 90 05-00	Nut Lock Hex Flange 5/16-18	227	817 49 05-12	Screw Thdrol 5/16-18 x 3/4
125	817 00 05-12	Screw 5/16-18 x 3/4	230	532 18 89-67	Washer Hardened
153	532 12 47-88	Retainer Spring	231	532 40 72-87	Idler V-Groove
159	876 02 04-12	Pin Cotter 1/8 x 3/4	284	532 41 76-93	Nut U-CHNL 1/4-20
160	532 16 94-84	Retainer Clip	307	874 18 04-12	Screw MACH CR 1/4-20 x 3/4
161	532 10 57-09	Spring, Return, Clutch	325	586 43 12-02	Torque Strap K46 LT LH
163	532 44 82-75	Rod Pedal Control	326	586 00 11-02	Bracket TRQ STP 46 20" Tire RH
166	532 42 91-64	Nut Push	334	585 88 22-02	Sway Bar Bracket
167	532 40 52-57	Latch Brake Parking	336	587 25 96-01	Bolt 5/16-18 x 1-3/4 Flanged
170	532 41 34-30	Keeper Belt Centerspan			
183	532 13 70-57	Spacer Split			
184	587 65 37-01	Handle Parking Brake			
185	872 11 06-22	Bolt Rdhd Sqnk 3/8-16 x 2-1/2			
186	532 19 43-21	Spacer Retainer			

NOTE: All component dimensions given in U.S. inches
1 inch = 25.4 mm

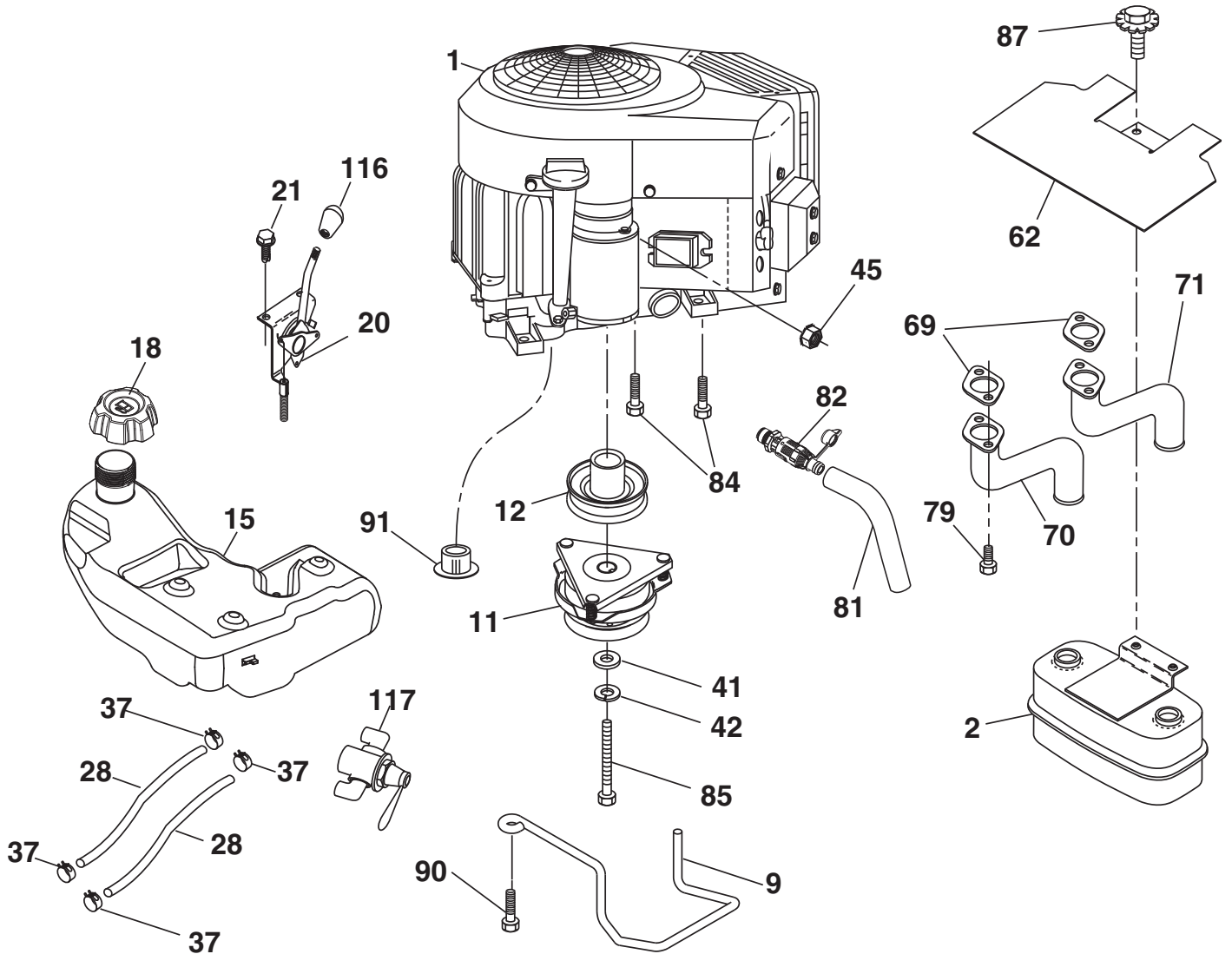

SPARK ARRESTER KIT

engine-tex_bs-2cyl_106

TRACTOR - MODEL NO. YTH2648TDRF (96041026403), PROD. NO. 960 41 02-64 ENGINE

KEY NO.	PART NO.	DESCRIPTION
1	-----	Engine Briggs Model No. 44P777-1573-G5(442257) (Order parts from engine manufacturer.)
2	532 44 59-62	Muffler
9	584 90 80-01	Keeper Belt Engine
11	532 40 00-08	Clutch Electric
12	532 40 50-97	Pulley Engine
15	532 42 28-04	Tank Fuel
18	584 24 87-02	Cap
20	586 21 96-01	Control Throttle
21	532 41 63-58	Screw #10 x .750 BOS Thread
28	532 40 11-35	Fuel Line
29	532 13 71-80	Spark Arrester Kit
37	532 12 34-87	Clamp Hose
41	532 12 61-97	Washer 1-1/2 OD x 15/32 ID x .250
42	810 04 07-00	Washer Lock 7/16
45	873 51 04-00	Nut Keps Hex 1/4-20 unc
62	532 43 40-17	Heat Shield
69	532 16 53-91	Gasket
70	581 88 11-01	Tube Exhaust
71	581 88 10-01	Exhaust Tube
79	532 18 39-06	Screw Socket HP 5/16-18 x 1
81	532 14 84-56	Tube Drain Oil
82	532 42 82-87	Valve, Oil Drain
84	817 06 06-20	Screw 3/8-16 x 1-1/4
85	532 17 39-37	Bolt Hex 7/16-20 x 4 x Gr. 5-1.5 Thr
87	537 17 18-77	Bolt 5/16-18 unc x 3/4 w/Sems
90	817 00 06-16	Screw 3/8-16 x 1
91	532 18 74-95	Bushing 1.375 OD
116	539 13 26-24	Knob-Shift
117	532 42 08-28	Valve Fuel Reserve

NOTE: All component dimensions given in U.S. inches
1 inch = 25.4 mm

Engine Power Rating Information

The gross power rating for individual gas engine models is labeled in accordance with SAE (Society of Automotive Engineers) code J1940 (Small Engine Power & Torque Rating Procedure), and rating performance has been obtained and corrected in accordance with SAE J1995 (Revision 2002-05). Torque values are derived at 3060 RPM; horsepower values are derived at 3600 RPM. Actual gross engine power will be lower and is affected by, among other things, ambient operating conditions and engine-to-engine variability. Given both the wide array of products on which engines are placed and the variety of environmental issues applicable to operating the equipment, the gas engine will not develop the rated gross power when used in a given piece of power equipment (actual "on-site" or net power). This difference is due to a variety of factors including, but not limited to, accessories (air cleaner, exhaust, charging, cooling, carburetor, fuel pump, etc.), application limitations, ambient operating conditions (temperature, humidity, altitude), and engine-to-engine variability. Due to manufacturing and capacity limitations, Briggs & Stratton may substitute an engine of higher rated power for this Series engine.

**TRACTOR - MODEL NO. YTH2648TDRF (96041026403), PROD. NO. 960 41 02-64
STEERING ASSEMBLY**

KEY NO.	PART NO.	DESCRIPTION
1	532 43 97-40	Wheel, Steering
2	532 43 68-70	Axle Asm., Front
4	532 43 68-73	Spindle Asm., LH
5	532 43 68-74	Spindle Asm., RH
6	532 12 49-31	Washer Thrust 0.75 x 1.23
7	532 12 17-48	Washer 25/32 x 1-5/8 x 16 Ga.
8	812 00 00-29	Ring, Klip #T5304-75
9	532 12 12-32	Cap, Spindle
13	532 12 17-49	Washer 25/32 x 1-1/4 x 16 Ga.
14	810 04 06-00	Washer, Lock 3/8
15	873 54 06-00	Nut, Crown Lock 3/8-24 unf
16	532 44 07-85	Shaft Steering (Two High Units)
19	532 19 47-29	Plate Steering
21	586 84 02-01	Adapter, Wheel Steering
22	532 19 48-45	Bushing, Strg. Blk
26	532 43 97-43	Insert, Wheel Steering
28	817 00 06-12	Screw 3/8-16 x 3/4
35	532 44 07-70	Gear, Sector Plate
45	819 18 38-12	Washer
50	873 96 06-00	Nut Lock Flg 3/8-16 unc
53	532 18 89-67	Washer Hardened .793 x 1.637 x .060
58	532 19 47-47	Bolt Shoulder Sector Pivot CFM
59	532 19 47-48	Washer Thrust Sector Steering
60	873 97 10-00	Nut Flange Lock 5/8-11
61	532 43 68-84	Draglink, LH
62	532 43 68-85	Draglink, RH
63	817 00 05-12	Screw 5/16-18 x 3/4
64	532 19 98-49	Retainer Clip Spring Steering
66	871 02 07-48	Bolt Hex Fghd 7/16-14 x 3 Serr
67	532 19 47-37	Bushing PM Front Axle
68	873 90 07-00	Nut Lock Flange 7/16-14 Gr. 5
69	532 19 91-62	Washer 1.5 x .505 x .118
70	585 33 88-01	Bracket Deck Susp. Front
80	532 00 13-70	Washer
81	532 43 68-87	Link Cross RH
82	532 44 21-47	Pivot Bolt
85	532 44 18-73	Pivot RH
86	532 44 18-72	Pivot LH
118	532 40 60-13	Bushing
122	532 44 49-62	Cap Gear

NOTE: All component dimensions given in U.S. inches
1 inch = 25.4 mm

TRACTOR - MODEL NO. YTH2648TDRF (96041026403), PROD. NO. 960 41 02-64
MOWER DECK

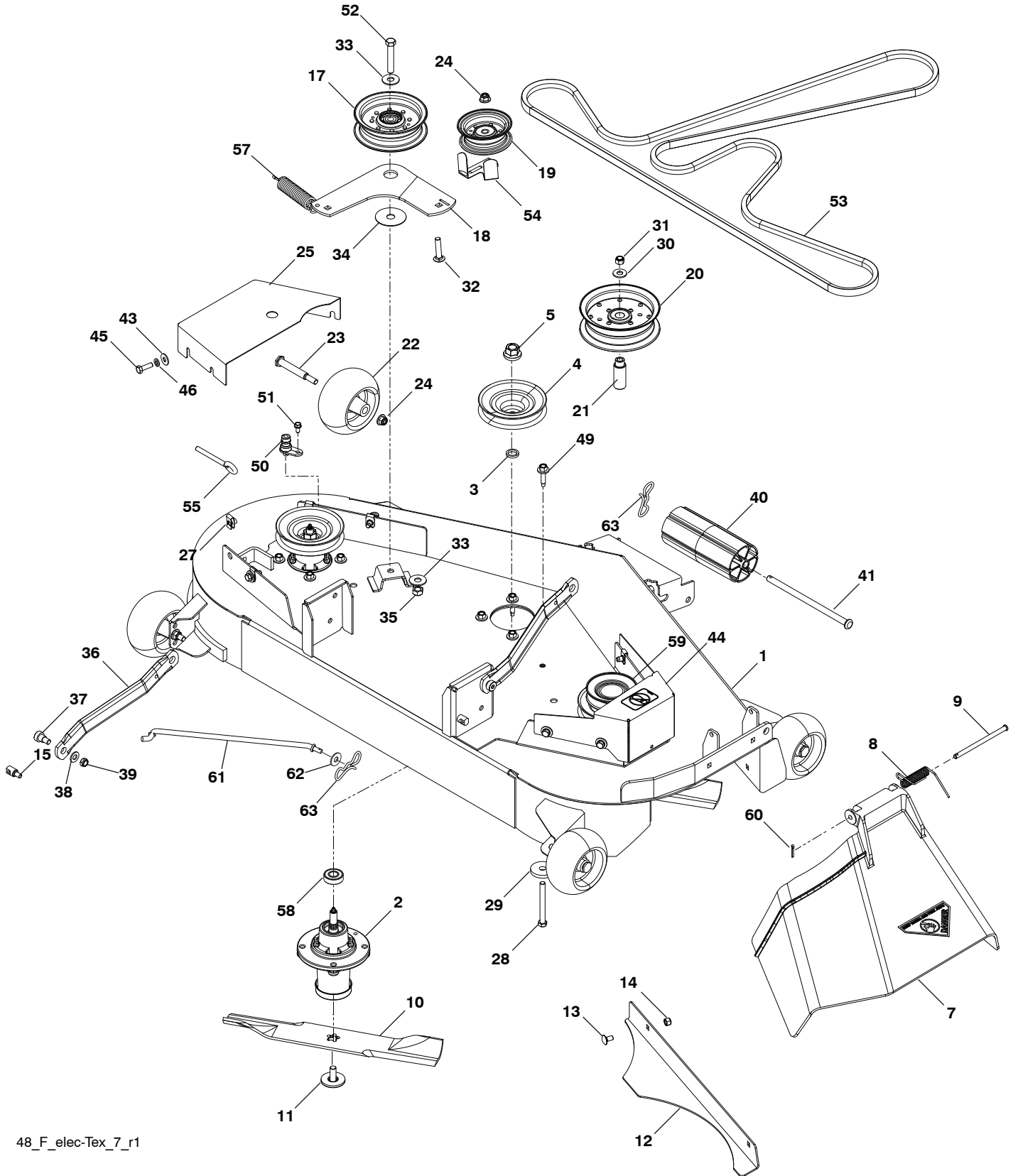

48_F_elec-Tex_7_r1

**TRACTOR - MODEL NO. YTH2648TDRF (96041026403), PROD. NO. 960 41 02-64
MOWER DECK**

KEY NO.	PART NO.	DESCRIPTION	KEY NO.	PART NO.	DESCRIPTION
1	574 80 89-02	Deck	37	539 11 36-21	Sb 3/8-16 x 3/8 Skt Hd
2	539 11 21-70	Housing Assembly	38	819 13 13-16	Washer, 13/32 x 13/16 x 16 Ga
3	532 18 76-90	Washer-Spacer	39	539 20 02-82	Nut, 3/8-16 Hex Jam Nyloc
4	532 17 43-75	Pulley, Mandrel	40	532 17 60-66	Roller, Nose
5	532 40 02-34	Nut, Flange Lock Top	41	532 17 91-27	Rod, Roller, Nose, Narrow
7	539 11 07-32	Discharge Chute	43	819 12 14-14	Washer, 3/8 x 7/8 x 14 Ga
8	539 11 07-35	Spring - Torsion	44	575 96 72-02	Shield, Belt RH
9	539 11 07-36	Pin, Clevis 5/16 x 5.19	45	874 78 05-16	Bolt Fin Hx 5/16-18 x 1
10	539 11 34-25	Blade, 16-1/4"	46	810 03 05-00	Wash 5/16 Slw
11	532 19 30-03	Bolt, Washer Asm 7/16-20	49	584 95 39-01	Bolt Hex
12	539 11 34-26	Confinement Plate	50	532 41 55-98	Washout Port
13	872 11 05-05	Rhsnb 5/16-18 x 5/8 Gr 5	51	817 49 04-08	Bolt, 1/4-20 x 1/2
14	873 80 05-00	Nut 5/16-18 Hex Nyloc	52	874 78 07-40	Hcs 7/16-14 x 2-1/2 Gr 5
15	532 19 51-61	Stud, Fasten w/ Anti- Rotate	53	574 84 56-02	Belt, Deck
17	532 19 61-04	Pulley, Idler Spec. Hub	54	532 14 10-43	Guard, Belt
18	574 82 71-01	Arm, Idler, Blk	55	539 11 55-74	Eyebolt 5/16 x 3-1/2
19	532 17 79-68	Pulley, Idler	57	539 10 68-50	Spring
20	539 13 27-28	Pulley, Idler	58	532 11 04-85	Ball Bearing
21	575 22 45-01	Idler Bushing	59	575 35 29-01	Pulley
22	532 13 39-57	Wheel, Gauge	60	532 16 94-84	Clip Retainer
23	532 19 34-06	Bolt, Shoulder 3/8 16 x 3-5/8	61	532 40 48-51	Rod Anti Sway
24	521 99 65-01	Nut 3/8-16 Hex Flg Nyloc	62	819 13 13-12	Washer 13/32 x 13/16 x 12 Ga.
25	575 22 47-02	Shield, Belt LH	63	532 19 42-08	Pin Cotter 5/16 Bow Tie Lock
27	539 10 47-63	Retainer 5/16c U Type	--	532 44 53-59	Mower Deck Complete
28	539 10 82-71	Hcs 3/8-16 x 3-1/2 Gr 5			
29	539 10 65-04	Heavy Washer			
30	819 14 16-14	Washer, 3/8 Flat Std			
31	539 97 69-79	Nut 3/8-16 Hex Nyloc			
32	539 99 09-23	Rhsnb 3/8-16 x 1-3/4 Gr 5			
33	539 10 48-64	Washer, 7/16 Flat			
34	532 17 85-15	Washer, Flat Hardened			
35	873 90 07-00	Nut, 7/16-14 Hex			
36	532 19 51-85	Arm, Susp., Rear			

NOTE: All component dimensions given in U.S. inches
1 inch = 25.4 mm

**TRACTOR - MODEL NO. YTH2648TDRF (96041026403), PROD. NO. 960 41 02-64
MOWER LIFT**

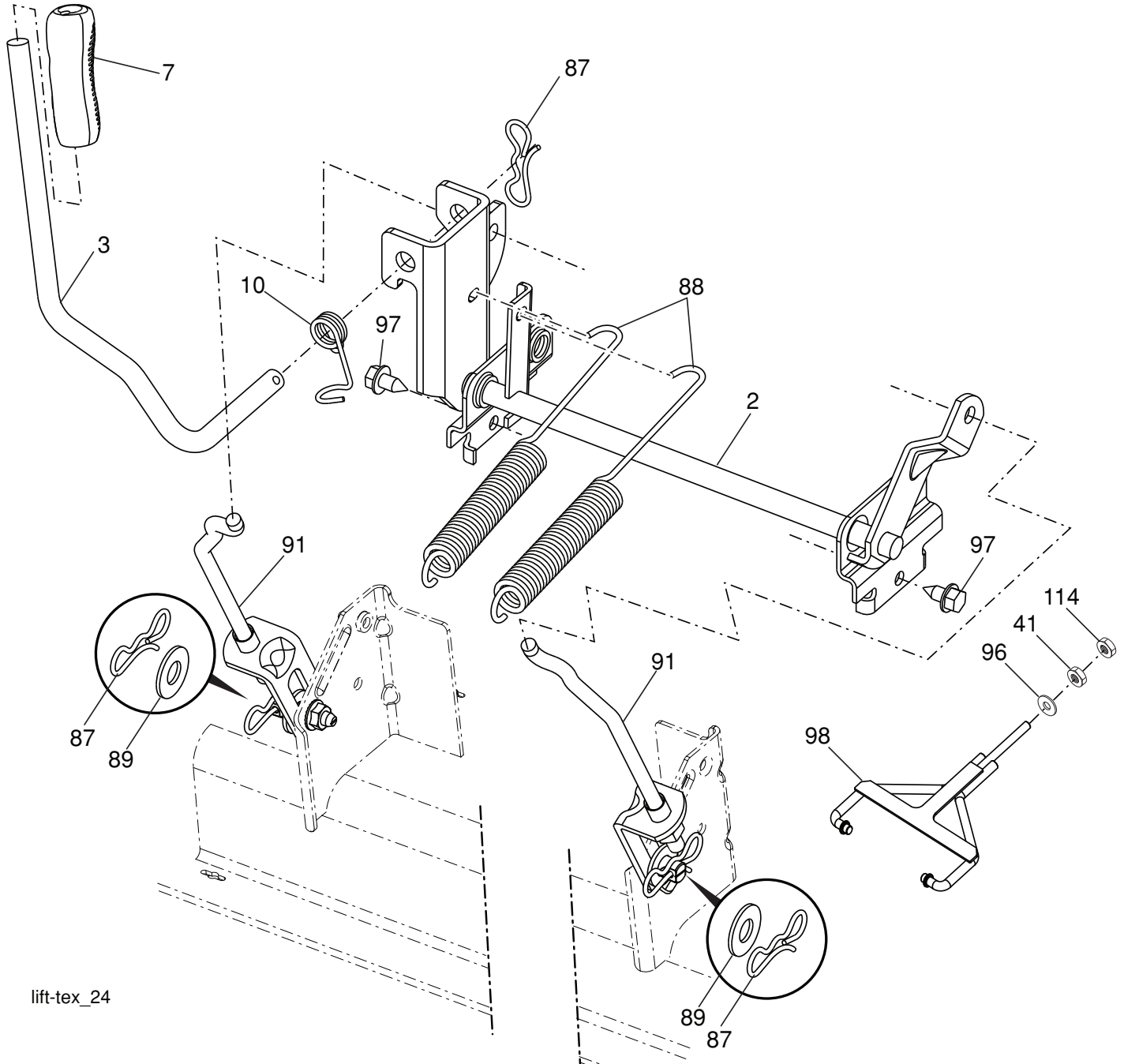

lift-tex_24

KEY NO.	PART NO.	DESCRIPTION
2	532 42 20-27	Shaft Asm., Lift
3	532 19 52-30	Lever Asm., Lift RH
7	580 96 23-01	Grip, Lever
10	532 19 63-14	Spring Torsion
41	532 17 59-94	Nut, Lift Link
87	532 19 42-09	Pin Cotter 7/16 Bow Tie Lock
88	532 41 07-10	Spring Lift Assist
89	819 19 19-12	Washer Clear Zinc

KEY NO.	PART NO.	DESCRIPTION
91	532 40 34-07	Link Lift Susp Mower Rear
96	532 19 52-63	Bushing, Spherical
97	817 00 06-12	Screw 3/8-16 x .75
98	574 82 25-01	Link Lift Susp. Front Mower
114	873 36 07-00	Nut Jam 7/16-20

NOTE: All component dimensions given in U.S. inches
1 inch = 25.4 mm

TRACTOR - MODEL NO. YTH2648TDRF (96041026403), PROD. NO. 960 41 02-64 SEAT ASSEMBLY

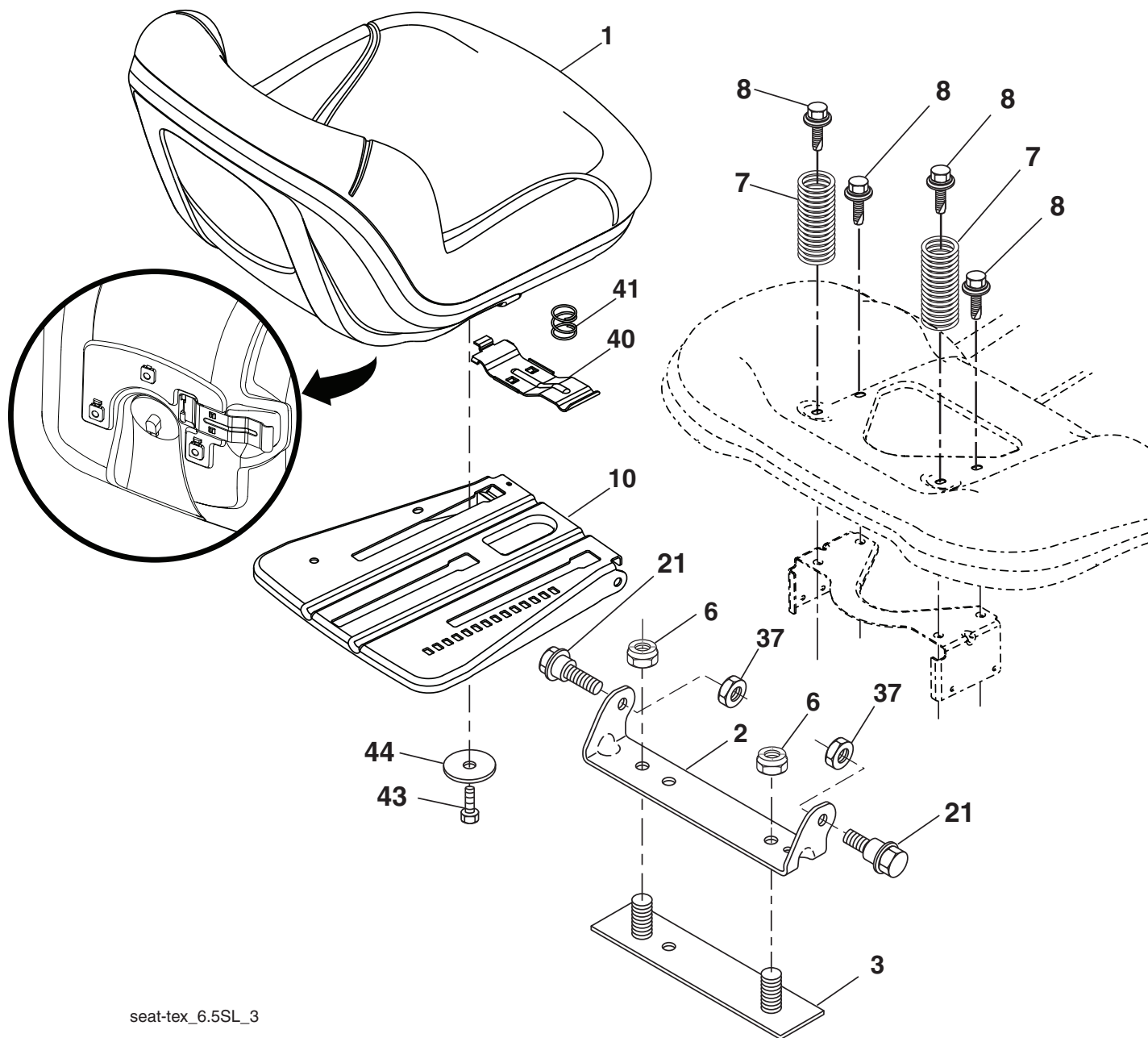

seat-tex_6.5SL_3

KEY NO.	PART NO.	DESCRIPTION
1	532 44 32-63	Seat
2	532 18 01-66	Bracket Pivot Fender
3	532 14 06-75	Strap, Asm Fender
6	873 80 06-00	Nut, Lock w/Ins. 3/8-16 unc
7	532 12 41-81	Spring, Seat Cprsn
8	532 17 18-77	Bolt 5/16-18 unc x 3/4 w/Sems
10	532 19 69-77	Pan, Seat
21	532 17 18-52	Bolt, Shoulder 5/16-18

KEY NO.	PART NO.	DESCRIPTION
37	873 80 05-00	Nut, Lock 5/16-18 unc
40	532 43 98-71	Handle Slide Seat
41	532 19 82-00	Spring Latch Seat
43	874 76 06-12	Bolt Fin Hex 3/8-16 unc x 3/4
44	819 13 38-12	Washer 13/32 x 2-3/8 x 12 Ga.

NOTE: All component dimensions given in U.S. inches
1 inch = 25.4 mm

**TRACTOR - MODEL NO. YTH2648TDRF (96041026403), PROD. NO. 960 41 02-64
DECALS**

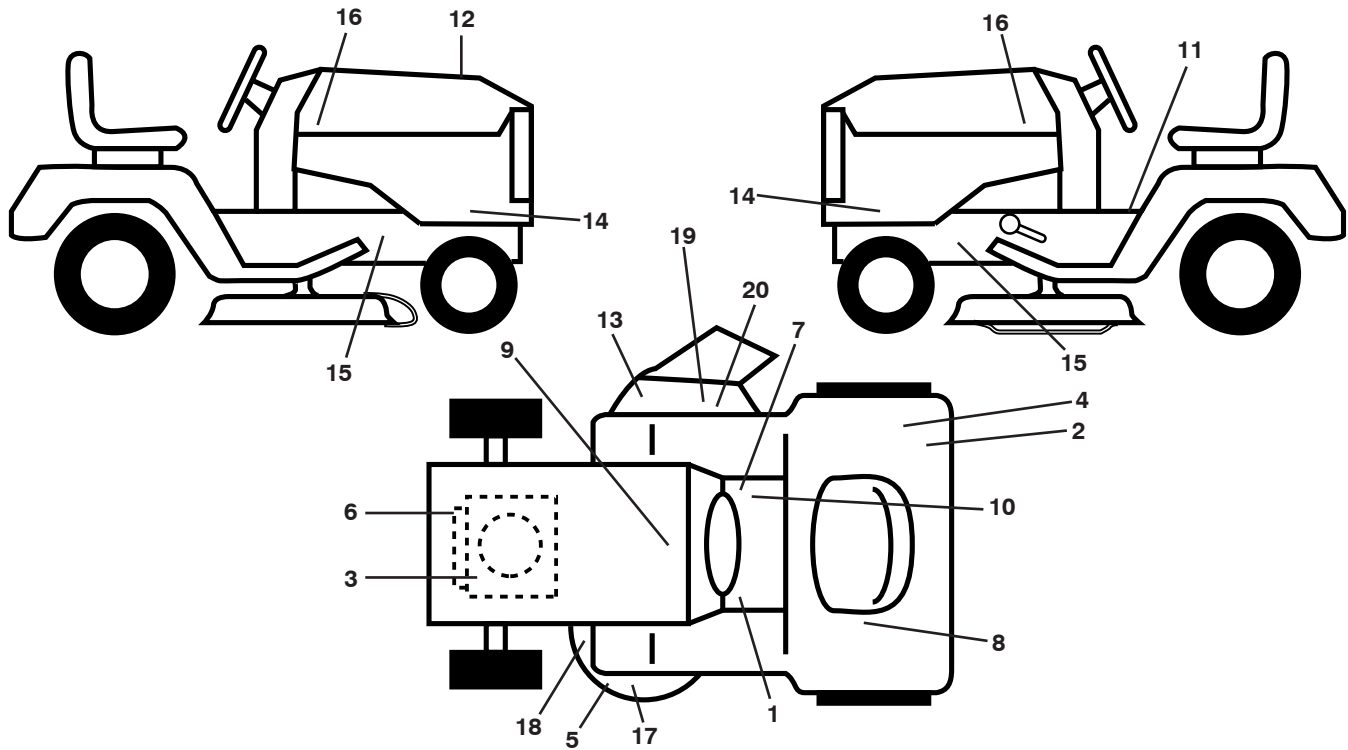

**KEY PART
NO. NO.**

KEY PART NO. NO.	DESCRIPTION
1 581 72 40-01	Decal, Brake/Clutch Sym
2 581 72 41-03	Decal, Tickmark
3 587 21 61-01	Decal, Eng. H.P.
4 581 72 41-02	Decal, 80 DBA
6 581 57 97-01	Decal, Warning Eng. Syms.
7 581 57 80-01	Decal, Saddle Brake Parking
8 587 01 51-01	Decal, Warn. Reserve Fuel
9 532 14 50-05	Decal, Battery Dan./Poi.
10 586 80 03-01	Decal, Oper. Cruise Sym.
11 581 57 81-01	Decal, Warning Sym. CE
12 587 56 35-01	Decal, RPL
13 581 72 44-01	Decal, Warning
14 532 44 44-61	Decal, Panel Side

**KEY PART
NO. NO.**

KEY PART NO. NO.	DESCRIPTION
15 581 57 96-01	Decal, Chassis Hot Muffler
16 581 62 73-01	Decal, Badge Logo
17 581 72 43-01	Decal, No Step
18 581 58 00-02	Decal, Mower DFLCTR Warning CTFNGR
19 584 57 92-01	Decal, defl.
20 584 90 46-01	Decal, Deck Lift
-- 581 72 48-01	Decal, Bypass
-- 532 43 98-82	Pad, Footrest, LH
-- 532 43 98-81	Pad, Footrest, RH
-- 581 72 46-01	Decal, Drawbar Load
-- 587 24 22-27	Manual, Oper. Eng.
-- 587 23 15-27	Manual, Parts

WHEELS AND TIRES

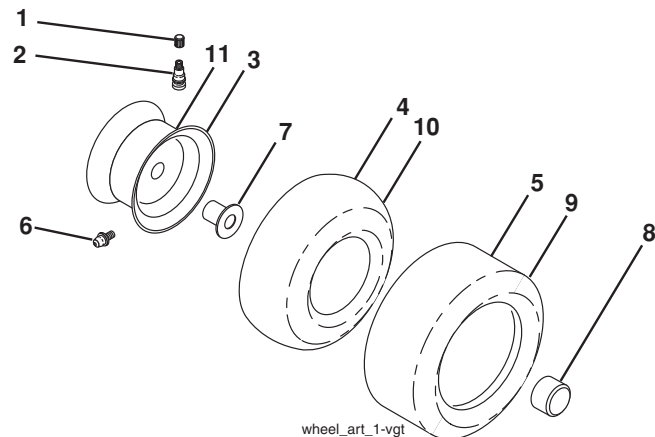

**KEY PART
NO. NO.**

KEY PART NO. NO.	DESCRIPTION
1 532 05 91-92	Cap, Valve, Tire
2 532 06 51-39	Stem, Valve
3 532 18 18-39	Rim Assembly, Front
4 532 00 81-34	Tube, Front (Service Item Only)
5 532 10 62-30	Tire, Front 16X6.5-8
6 532 12 49-57	Fitting, Grease (Front Wheel Only)
7 532 12 49-59	Bearing, Flange (Front Wheel Only)
8 532 17 50-39	Cap, Axle
9 532 12 20-82	Tire, Rear 20X10-8
10 532 12 49-26	Tube, Rear (Service Item Only)
11 532 13 83-37	Rim Assembly, Rear
-- 532 14 43-34	Sealant, Tire (10 oz. Tube)

NOTE: All component dimensions given in U.S. inches
1 inch = 25.4 mm

SERVICE NOTES

11/07/2014 BD