

ILLUSTRATED PARTS LIST

MODEL NO. 96041036601

CUSTOMER CATALOG NO. TS 38

PRODUCT NO. 960 41 03-66

47

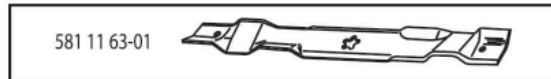
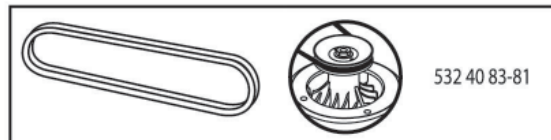
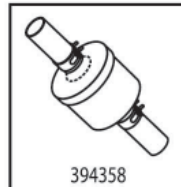
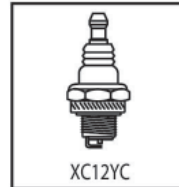
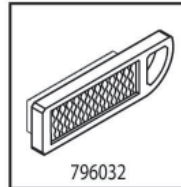

587027301

**TRACTOR - - MODEL NO. TS 38 (96041036601), PRODUCT NO. 960 41 03-66
DECALS 27**

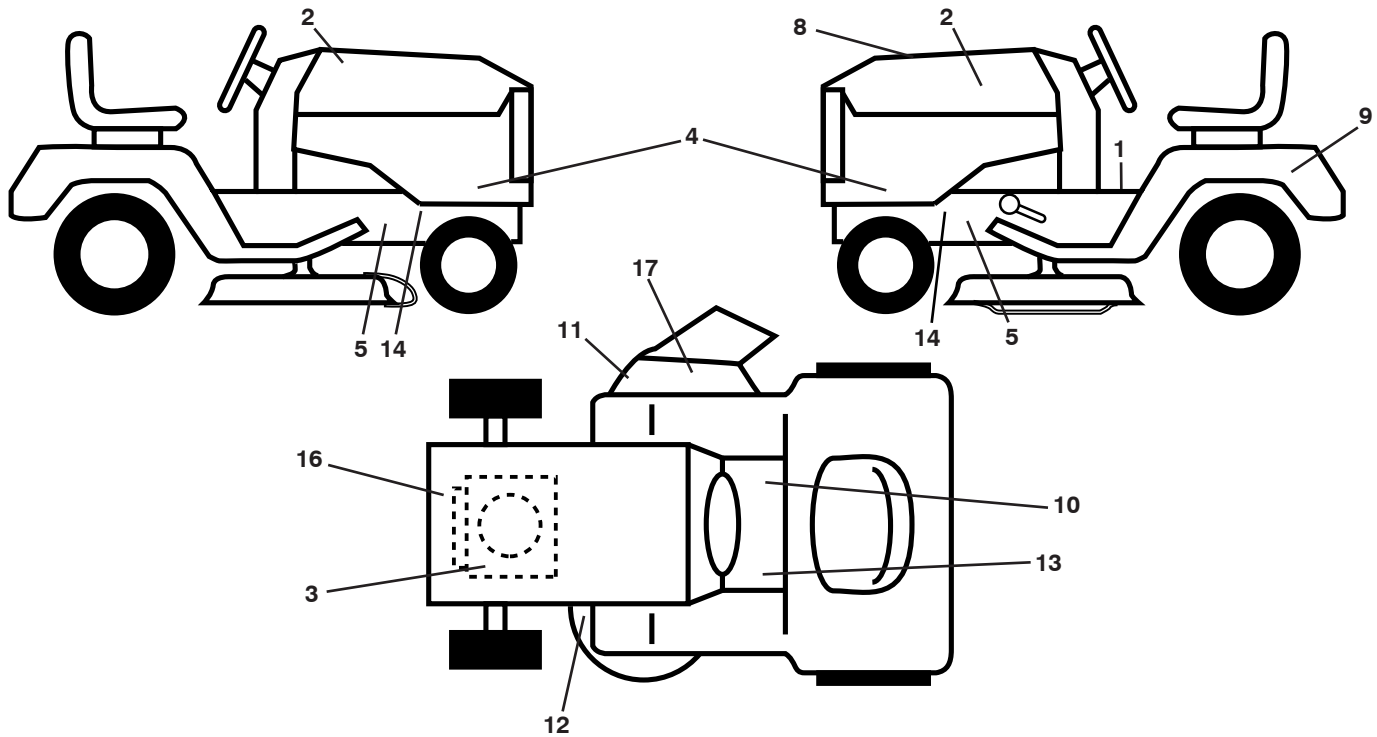

KEY NO.	PART NO.	DESCRIPTION
1	581 57 81-01	Decal, Operators
2	581 62 73-01	Hood Emblem
3	581 57 97-01	Decal, Warning Eng. Symbols
4	587 12 02-01	Decal, Hood Panel
5	581 57 96-01	Decal, Chassis Hot Muffler
8	587 02 73-01	Decal, Rpl.
9	532 14 50-05	Decal, Battery Dan./Poi.
10	581 57 80-01	Decal, Saddle Brake Parking
11	581 57 92-01	Decal, Warning
12	581 58 00-03	Decal, Mower V-Belt Schematic
13	581 72 40-01	Decal, Brake/Clutch Symbol

KEY NO.	PART NO.	DESCRIPTION
14	581 57 98-01	Decal, Warning-Service/Fire
16	585 56 13-01	Decal, Eng. BS
17	584 90 46-01	Decal, Deflect. Warning
--	581 72 46-01	Decal, Drawbar Load Limit
--	532 43 96-81	Pad, Footrest, LH
--	532 43 99-66	Pad, Footrest, RH
--	115 79 04-40	Manual Oper. Euro
--	115 79 05-20	Manual Oper. Scan
--	115 79 06-50	Manual Oper. Ebloc
--	115 79 07-30	Manual Oper. Baltic

WHEELS AND TIRES

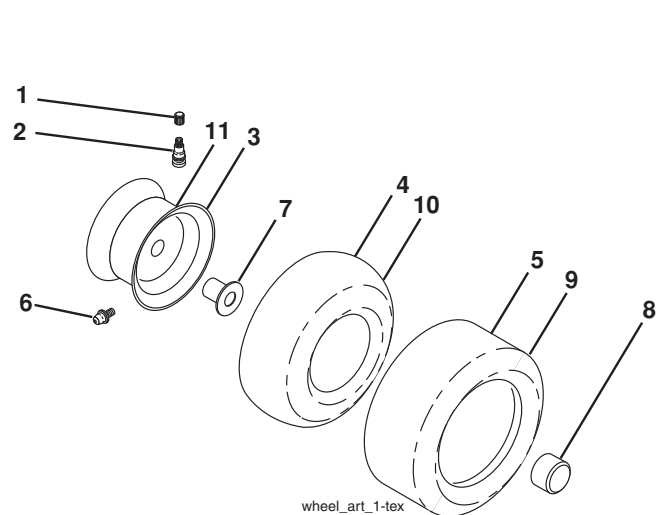

KEY NO.	PART NO.	DESCRIPTION
1	532 05 91-92	Cap Valve Tire
2	532 06 51-39	Stem Valve
3	532 13 83-36	Rim Asm. 6" Front
4	532 05 99-04	Tube Front (Service Item Only)
5	532 10 62-22	Tire Front 15 x 6-6
6	532 12 49-57	Fitting Grease (Front Wheel Only)
7	532 12 49-59	Bearing Flange (Front Wheel Only)
8	532 17 50-39	Cap Axle Blk. 1 50 x 1 00
9	532 12 46-35	Tire Rear 18 x 8.5-8
10	532 12 49-26	Tube Rear (Service Item Only)
11	532 13 83-37	Rim Asm. 8" Rear
--	532 14 43-34	Sealant, Tire (10 oz. Tube)

NOTE: All component dimensions given in U.S. inches
1 inch = 25.4 mm

TRACTOR - - MODEL NO. TS 38 (96041036601), PRODUCT NO. 960 41 03-66

SCHEMATIC **38**

SCH11

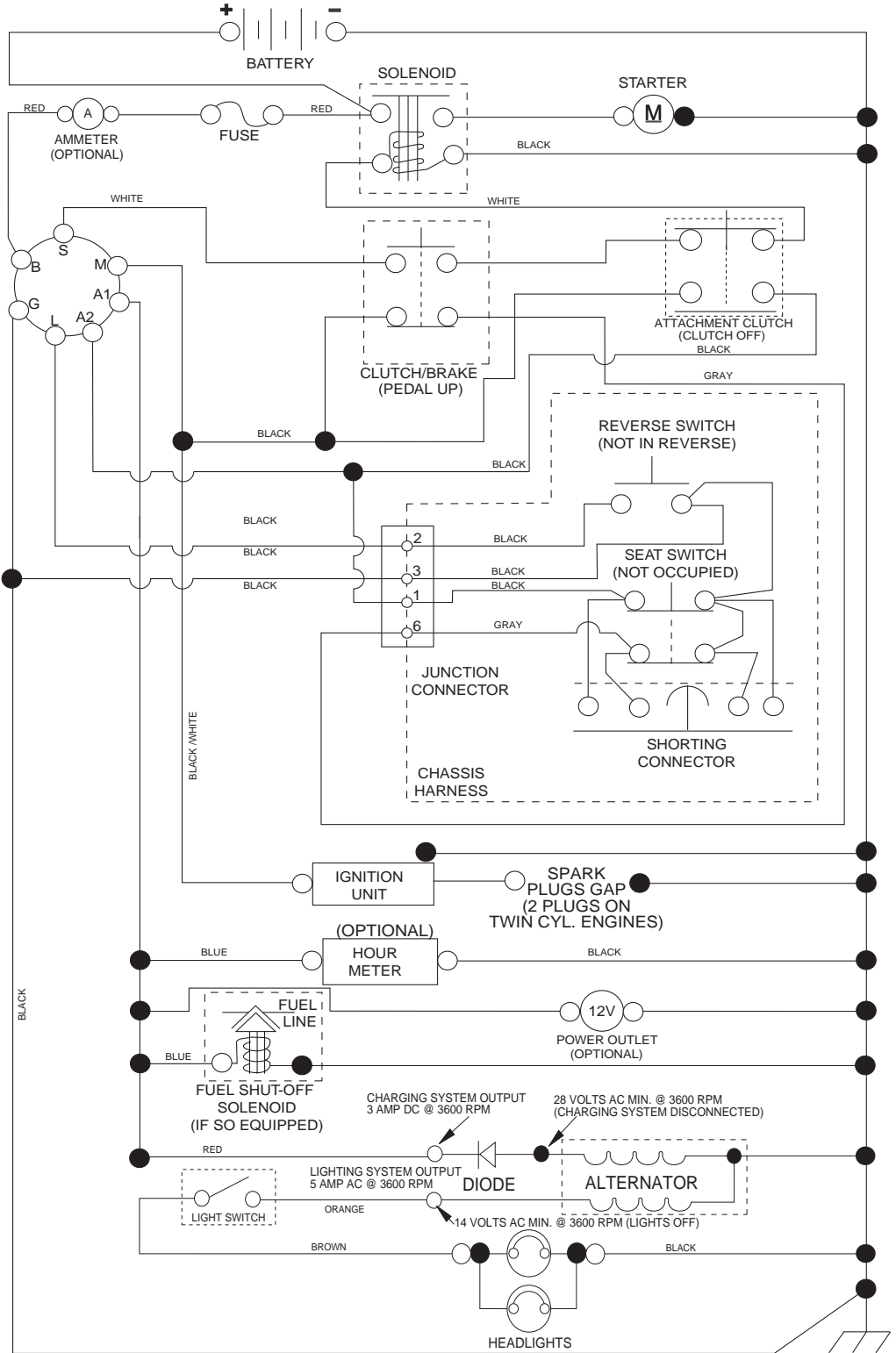

NOTE
YOUR TRACTOR IS EQUIPPED WITH A SPECIAL ALTERNATOR SYSTEM. THE LIGHTS ARE NOT CONNECTED TO THE BATTERY, BUT HAVE THEIR OWN ELECTRICAL SOURCE. BECAUSE OF THIS, THE BRIGHTNESS OF THE LIGHTS WILL CHANGE WITH ENGINE SPEED. AT IDLE THE LIGHTS WILL DIM. AS THE ENGINE IS SPEEDED UP, THE LIGHTS WILL BECOME THEIR BRIGHTEST.

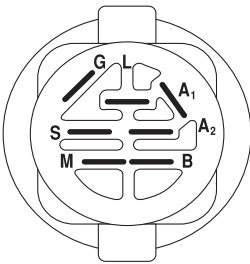

IGNITION SWITCH

POSITION	CIRCUIT	"MAKE"
OFF	M+G+A1	
RUN/OVERRIDE	B+A1	
RUN	B+A1	L+A2
START	B + S + A1	

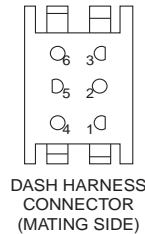
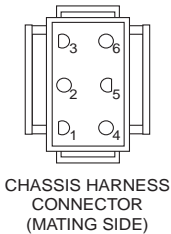

WIRING INSULATED CLIPS
NOTE: IF WIRING INSULATED CLIPS WERE REMOVED FOR SERVICING OF UNIT, THEY SHOULD BE RE-INSTALLED TO PROPERLY SECURE YOUR WIRING.

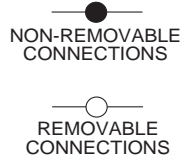

TRACTOR - - MODEL NO. TS 38 (96041036601), PRODUCT NO. 960 41 03-66
ELECTRICAL 32

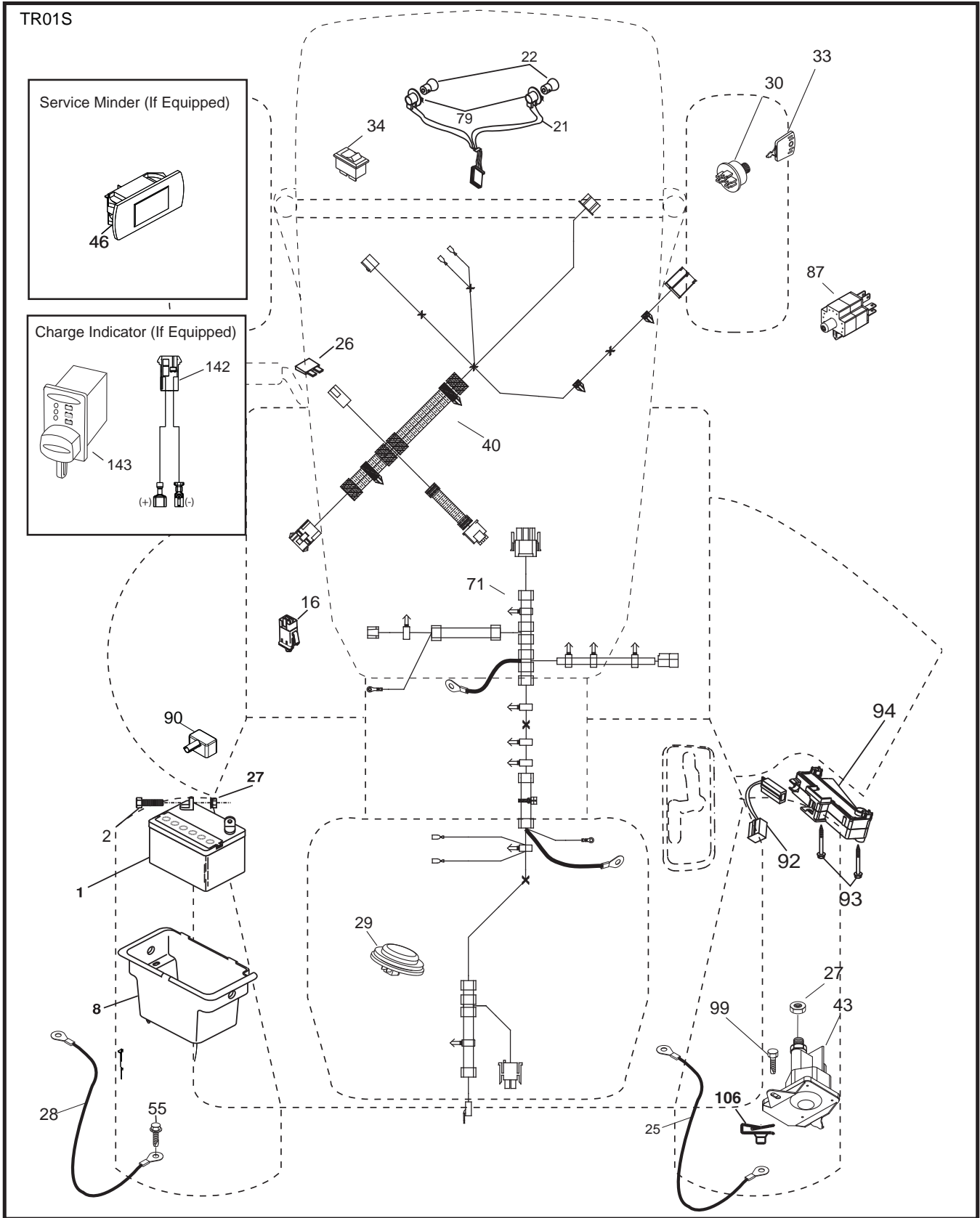

**TRACTOR - - MODEL NO. TS 38 (96041036601), PRODUCT NO. 960 41 03-66
ELECTRICAL 32**

KEY NO.	PART NO.	DESCRIPTION
1	532 16 34-65	Battery
2	874 76 04-12	Bolt Hex Head 1/4-20 x 3/4
8	532 19 32-28	Box Battery
16	532 17 61-38	Switch Interlock Push-In
21	532 40 02-52	Harness Socket Light w/4152J
22	532 00 41-52	Bulb Light
25	581 49 80-01	Cable Starter
26	532 17 51-58	Fuse
27	873 51 04-00	Nut Keps Hex 1/4-20 unc
28	532 42 16-86	Cable, Ground
29	532 40 15-45	Switch, Seat
30	532 19 33-50	Switch, Ign.
33	532 41 19-35	Key/Chain
34	532 11 07-12	Switch Light/Reset
40	581 02 31-01	Harness Ign. Dash
43	532 19 25-07	Solenoid
55	817 06 05-12	Screw Thdrol. 5/16-18 x 3/4 TYTT
71	501 13 37-01	Harness Chassis
79	532 17 52-42	Socket Asm. Bulb Twistlock
87	532 19 78-02	Switch Interlock Clutch Cable
90	532 43 53-95	Cover Terminal
92	532 19 66-15	Harness Pigtail Reverse Switch
93	532 19 25-40	Screw Plastite 10-14 x 2.0
94	532 19 18-34	Module Reverse ROS
99	817 67 04-12	Screw 1/4-20 x 3/4
106	532 17 48-14	Palnut 1/4 Lugs

NOTE: All component dimensions given in U.S. inches
1 inch = 25.4 mm

**TRACTOR - - MODEL NO. TS 38 (96041036601), PRODUCT NO. 960 41 03-66
CHASSIS AND ENCLOSURES 39**

KEY NO.	PART NO.	DESCRIPTION	KEY NO.	PART NO.	DESCRIPTION
3	581 05 63-01	Logo	195	532 43 99-76	Plug Dash
5	501 86 11-01	Dash	196	532 43 96-47	Console Deck Lift
14	532 44 12-67	Hood	201	819 13 20-16	Washer 13/32 x 1-1/4 x 16 Ga.
15	532 44 14-28	Lens LH	202	532 44 13-42	Vent Side Hood RH
18	532 44 13-68	Grille	203	532 44 13-43	Vent Side Hood LH
25	532 44 14-27	Lens RH	204	532 44 13-75	Vent Top Hood
34	580 91 08-01	Plate Engine	205	532 44 13-44	Skirt Side RH
36	817 06 05-12	Screw 5/16-18 x 3/4	206	532 44 13-45	Skirt Side LH
37	532 44 12-66	Fender	213	874 76 05-12	Bolt 5/16-18 unc x 3/4
52	873 68 05-00	Nut Crown Lock 5/16-18	214	532 19 91-45	Clip Retainer
58	532 41 22-80	Drawbar Upper	217	532 40 91-67	Rod Pivot Hood
68	817 49 05-08	Screw Thdrol. 5/16-18 x 1/2	218	532 19 63-95	X-Piece Hood Stop
125	581 68 48-01	Clip Fuel Line	228	532 19 51-61	Stud Fastener
130	532 41 63-58	Screw #10 x 0.750 BOS Thread	235	532 40 61-29	Spacer Fender
137	532 40 75-90	Bumper Dash	236	873 93 05-00	Nut Lock 5/16-18 unc
138	532 43 97-47	Cupholder	238	532 44 13-74	Trim
146	581 85 79-01	Bolt	239	532 40 48-83	Clip Tinnerman
150	532 40 66-62	Air Duct	287	817 60 04-06	Screw Hex WASHEAD 1/4-20 x 3/8
151	532 40 78-07	Bracket Pivot	297	532 40 66-65	Insert Reflective LH
152	532 19 95-35	Shield Browning	303	587 49 34-02	Shield Chassis French LH
159	817 00 06-12	Screw 3/8 - 16 x 3/4	304	587 86 51-02	Shield Chassis French RH
162	532 14 24-32	Screw Hex Wsh. Hi-Lo 1/4 x 1/2	306	873 90 06-00	Nut Lock FLG 3/8-16 unc
175	532 19 94-72	Crossmember	307	587 49 46-01	Shield Upper
176	532 40 07-76	Screw 10-24 x 5/8	308	532 17 18-77	Bolt 5/16-18 unc x 3/4
177	532 19 52-28	Bushing Steering	312	587 49 30-02	Shield Drawbar French
180	532 41 50-63	Chassis	375	586 90 82-01	Dash Clip-On Bumper
181	532 43 97-46	Bushing			
182	532 40 71-76	Dash Lower			
183	874 52 05-20	Bolt 5/16-18 unc x 1-1/4			
184	587 55 41-01	Plug			
189	817 00 05-12	Screw 5/16-18 x 3/4			
191	532 41 65-01	Insert Reflective RH			
194	873 90 05-00	Nut Lock Hex Flange 5/16-18			

NOTE: All component dimensions given in U.S. inches
1 inch = 25.4 mm

TRACTOR - - MODEL NO. TS 38 (96041036601), PRODUCT NO. 960 41 03-66
DRIVE **40**

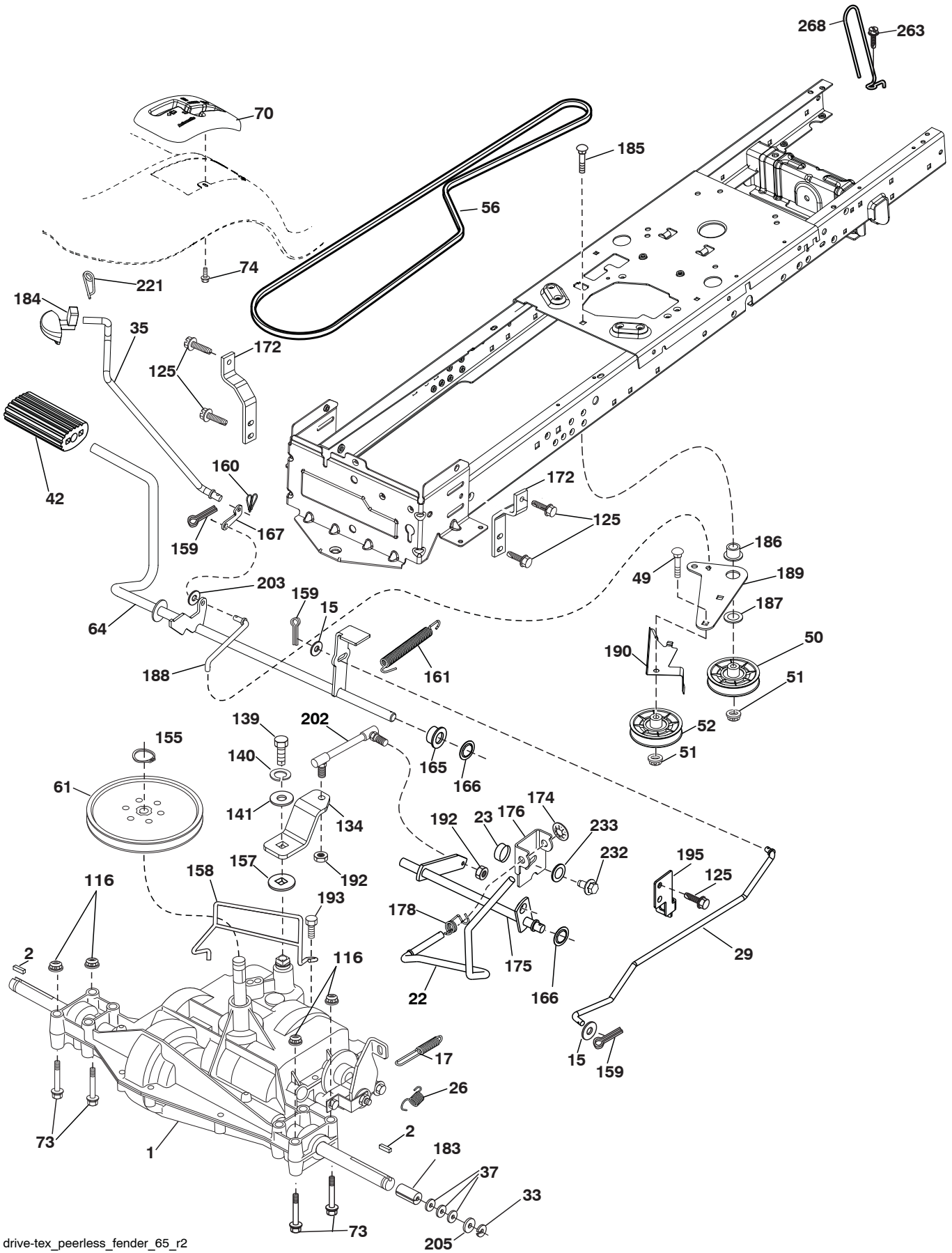

drive-tex_peerless_fender_65_r2

**TRACTOR - - MODEL NO. TS 38 (96041036601), PRODUCT NO. 960 41 03-66
DRIVE 40**

KEY NO.	PART NO.	DESCRIPTION	KEY NO.	PART NO.	DESCRIPTION
1	-----	Transaxle, Peerless 206-565 (197941) (Order parts from trans-axle manufacturer.)	160	532 16 94-84	Retainer Clip
2	532 12 35-83	Key Square	161	532 10 57-09	Spring, Return, Clutch
15	819 13 13-16	Washer 13/32 x 13/16 x 16 Ga.	165	532 19 62-12	Bushing Shaft Brake Hand Control
17	532 19 72-97	Spring, Brake	166	532 42 91-64	Nut Push .625
22	532 19 76-60	Rod Shift	167	532 40 52-57	Latch Brake Parking
23	532 12 12-74	Knob Duckhead 1/2-13	172	532 19 76-57	Strap Torque LH
26	532 19 74-55	Spring Brake Return	174	532 19 72-89	Nut Push
29	532 19 72-67	Rod, Brake	175	532 19 78-58	Shaft Asm. Shift
33	812 00 00-01	Ring E	176	532 19 62-14	Arm Clevis Rod Shift
35	532 40 10-31	Rod, Brake, Park	178	532 19 74-56	Spring Shift
37	532 12 17-49	Washer 25/32 x 1-1/4 x 16 Ga.	183	532 13 70-57	Spacer Axle
42	532 12 48-72	Cover, Foot Pedal	184	532 41 14-84	Knob
49	872 11 06-14	Bolt	185	872 11 06-22	Bolt Rdhd 3/8-16 unc x 2-3/4 Gr. 5
50	532 19 43-27	Pulley Idler Flat	186	532 19 43-21	Spacer Retainer
51	873 90 06-00	Lock Nut 3/8-16	187	819 13 32-10	Washer
52	532 19 43-26	Idler V-Groove	188	582 21 70-01	Link Clutch Ground Drive, Long
56	532 19 43-46	V-Belt, Drive	189	532 19 43-17	Bellcrank Ground Drive
61	532 12 36-66	Pulley Transaxle	190	532 19 43-18	Keeper Bellcrank Ground Drive
64	532 19 62-00	Shaft Asm. Pedal Brake Control	192	532 15 03-60	Nut Lock Center 1/4-28 Fnthd.
70	581 45 43-01	Console Shift	193	817 06 05-12	Screw 5/16-18 x 3/4
74	532 14 24-32	Screw	195	532 19 73-32	Bracket Brake Rod
73	874 49 05-40	Bolt Hex Flghd. 5/16-18 x 2-1/2 Gr. 5	202	532 19 78-59	Link Transaxle
116	873 90 05-00	Nut Lock Hex Flange 5/16-18	203	819 11 11-16	Washer 11/32 x 11/16 x 16 Ga.
125	817 00 05-12	Screw 5/16-18 x 3/4	205	532 12 17-48	Washer 25/32 x 1-5/8 16 Ga.
134	532 19 78-57	Asm. Shift	221	532 40 31-87	Retainer Spring Clip Handle
139	874 55 04-12	Bolt 1/4-28 unf Gr. 8 w/Patch	232	874 78 07-16	Bolt Fin. Hex 7/16-14 x 1 Gr. 5
140	810 04 04-00	Washer Lock Hvy. Helical 1/4	233	532 40 52-96	Washer Serrated
141	819 09 12-10	Washer 9/32 x 3/4 x 10 Ga.	263	817 00 06-12	Screw
155	812 00 00-28	Ring Retainer	268	532 18 24-02	Guard Muffler
157	532 10 57-01	Washer Plate Shift			
158	532 19 43-52	Belt Keeper			
159	876 02 04-12	Pin Cotter 1/8 x 3/4			

NOTE: All component dimensions given in U.S. inches
1 inch = 25.4 mm

**TRACTOR - - MODEL NO. TS 38 (96041036601), PRODUCT NO. 960 41 03-66
ENGINE 24**

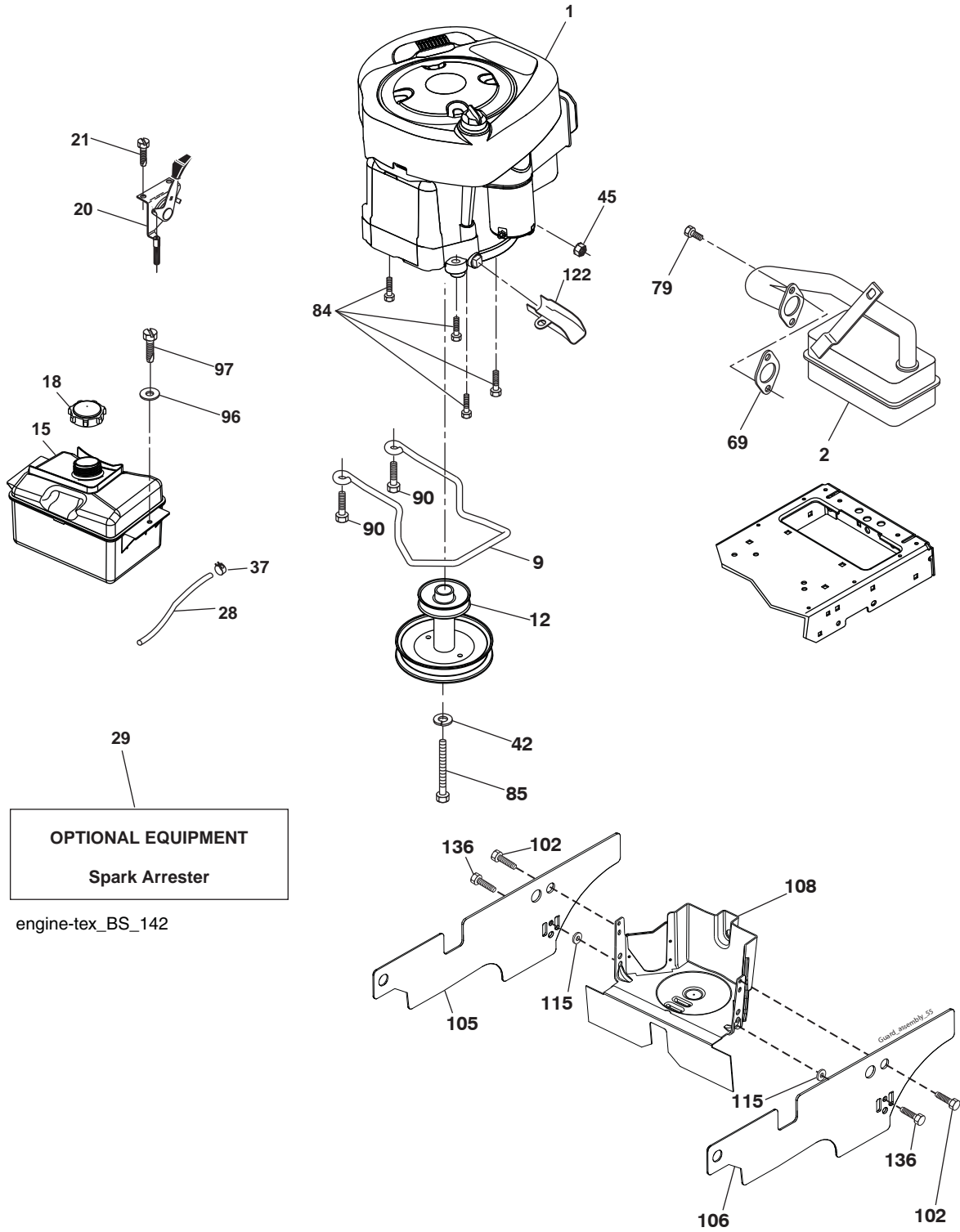

**TRACTOR - - MODEL NO. TS 38 (96041036601), PRODUCT NO. 960 41 03-66
ENGINE 24**

KEY NO.	PART NO.	DESCRIPTION
1	-----	Engine Briggs Model No. 21R707-0115-B1 (501303601) (Order parts from engine manufacturer.)
2	532 17 97-58	Muffler
9	582 54 03-02	Keeper Belt Engine
12	586 72 90-01	Pulley Engine
15	581 28 99-01	Tank Fuel
18	532 43 02-20	Cap Asm
20	532 18 38-97	Control Throttle
21	532 41 63-58	Screw #10 x 0.750 BOS Thread
28	532 13 70-40	Fuel Line
29	532 13 71-80	Spark Arrester Kit
37	532 12 34-87	Clamp Hose
42	810 04 07-00	Washer Lock 7/16
45	873 51 04-00	Nut Keps Hex 1/4-20 unc
69	532 16 52-91	Gasket
79	532 19 23-34	Screw 5/16-18 x 3/4
84	817 06 06-20	Screw 3/8-16 x 1/4
85	532 17 39-37	Bolt Hex 7/16-20 x Gr. 5-1.5
90	817 00 06-16	Screw 3/8-16 x 1
96	819 09 14-16	Washer 9/32 x 7/8 x 16 Ga.
97	817 67 04-12	Screw 1/4-20 x 3/4
102	817 00 05-12	Screw
105	501 26 72-02	Shield Side LH
106	501 26 82-02	Shield Side RH
108	587 17 95-01	Cover Eng. Pulley w/SHLD 38", 42"
115	532 43 17-61	Palnut #10
122	532 42 19-22	Extension Drain Oil
136	532 42 17-56	Screw, #10 0.500, BOS

NOTE: All component dimensions given in U.S. inches
1 inch = 25.4 mm

Engine Power Rating Information

The gross power rating for individual gas engine models is labeled in accordance with SAE (Society of Automotive Engineers) code J1940 (Small Engine Power & Torque Rating Procedure), and rating performance has been obtained and corrected in accordance with SAE J1995 (Revision 2002-05). Torque values are derived at 3060 RPM; horsepower values are derived at 3600 RPM. Actual gross engine power will be lower and is affected by, among other things, ambient operating conditions and engine-to-engine variability. Given both the wide array of products on which engines are placed and the variety of environmental issues applicable to operating the equipment, the gas engine will not develop the rated gross power when used in a given piece of power equipment (actual "on-site" or net power). This difference is due to a variety of factors including, but not limited to, accessories (air cleaner, exhaust, charging, cooling, carburetor, fuel pump, etc.), application limitations, ambient operating conditions (temperature, humidity, altitude), and engine-to-engine variability. Due to manufacturing and capacity limitations, Briggs & Stratton may substitute an engine of higher rated power for this Series engine.

TRACTOR - - MODEL NO. TS 38 (96041036601), PRODUCT NO. 960 41 03-66
STEERING ASSEMBLY [41]

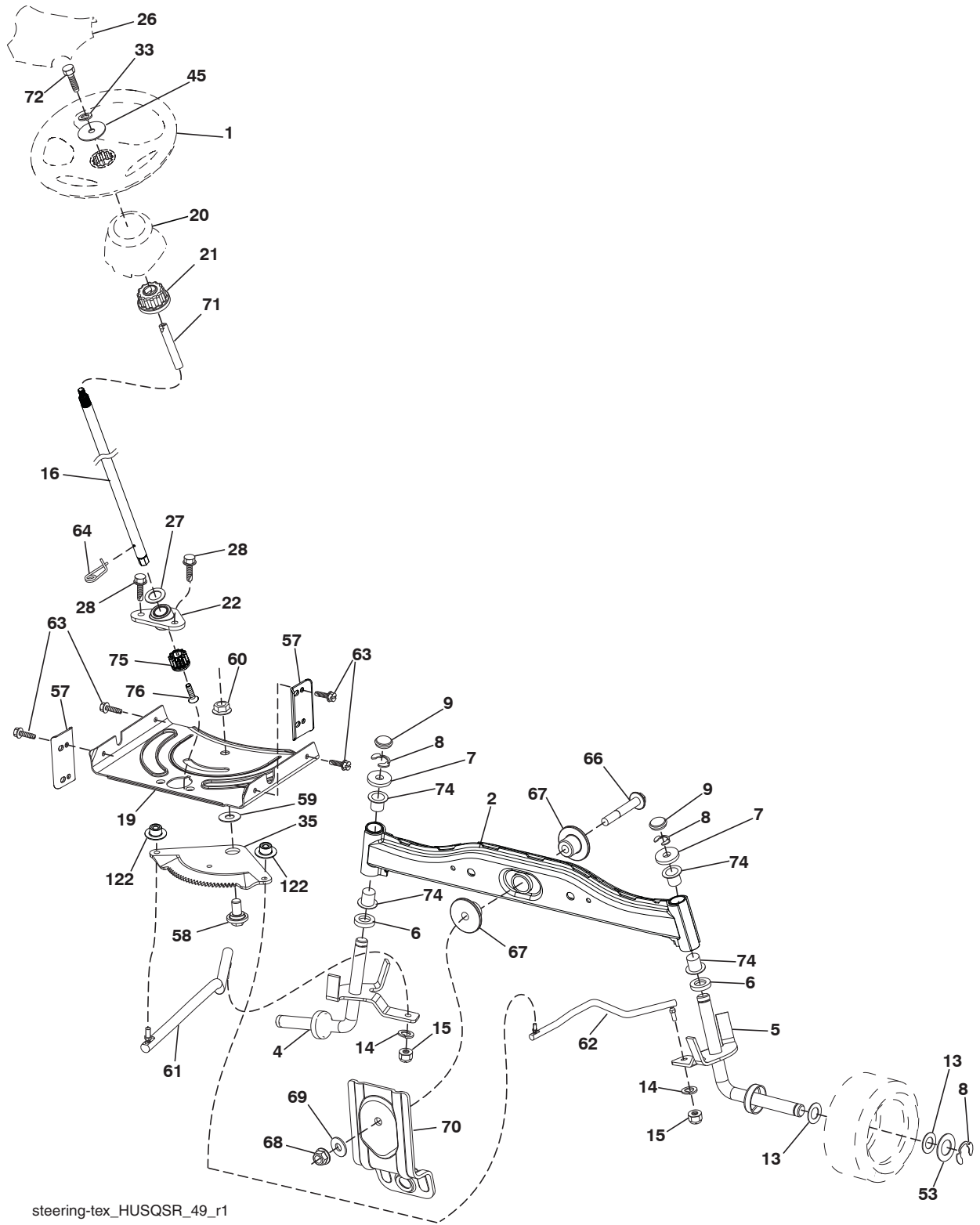

steering-tex_HUSQSR_49_r1

**TRACTOR - - MODEL NO. TS 38 (96041036601), PRODUCT NO. 960 41 03-66
STEERING ASSEMBLY **41****

KEY NO.	PART NO.	DESCRIPTION
1	532 43 99-97	Wheel, Steering Husq SR
2	532 41 81-68	Axle Asm., Front
4	532 40 30-87	Spindle Asm., LH
5	532 40 30-88	Spindle Asm., RH
6	532 12 49-31	Bearing, Race Thrust Hardened
7	532 12 17-48	Washer 25/32 x 1-5/8 x 16 Ga.
8	812 00 00-29	Ring, Clip #T5304-75
9	532 12 12-32	Cap, Spindle
13	532 12 17-49	Washer 25/32 x 1-1/4 x 16 Ga.
14	810 04 06-00	Washer, Lock Hvy. Hlcl. Spr. 3/8
15	873 54 06-00	Nut, Crown Lock 3/8-24 unf
16	585 86 92-02	Steering Shaft
19	532 19 47-29	Plate Steering
20	532 44 14-25	Boot, Steering
21	532 18 67-37	Adapter, Wheel Steering
22	585 02 98-02	Bearing
26	532 43 97-43	Insert, Wheel Steering Husq SR
27	819 21 16-16	Washer 21 x 32 x 1 x 16 Ga.
28	817 00 06-12	Screw 3/8-16 x 3/4
33	810 04 05-00	Washer Lock 5/16
35	532 19 47-32	Gear, Sector Plate
45	819 11 38-12	Washer 11/32 x 3/8 x 12 Ga.
53	532 18 89-67	Washer Hardened .793 x 1.637 x .060
57	532 40 74-65	Bracket Upstop
58	532 19 47-47	Bolt Shoulder Sector Pivot CFM
59	532 19 47-48	Washer Thrust Sector Steering
60	873 97 10-00	Nut Flange Lock 5/8-11
61	532 19 47-40	Draglink, LH
62	532 19 47-41	Draglink, RH
63	817 00 05-12	Screw 5/16-18 x 3/4
64	532 19 98-49	Retainer Clip Spring Steering
66	871 02 07-48	Bolt Hex Fghd. 7/16-14 x 3 Serr.
67	532 19 47-37	Bushing PM Front Axle
68	873 90 07-00	Nut Lock Flange 7/16-14 Gr. 5
69	532 19 91-62	Washer 1.5 x .505 x .118
70	585 33 88-01	Bracket Deck Susp. Front
71	532 19 07-52	Shaft Extension Steering
72	532 42 89-82	Bolt Fin Hx 5/16-18 x 4 w/Patch
74	532 12 49-37	Bearing Col. STRG
75	580 68 37-01	Pinion
76	580 68 36-01	Screw Head Sock
122	532 44 49-62	Cap Gear Sector

NOTE: All component dimensions given in U.S. inches
1 inch = 25.4 mm

TRACTOR - - MODEL NO. TS 38 (96041036601), PRODUCT NO. 960 41 03-66
MOWER DECK **44**

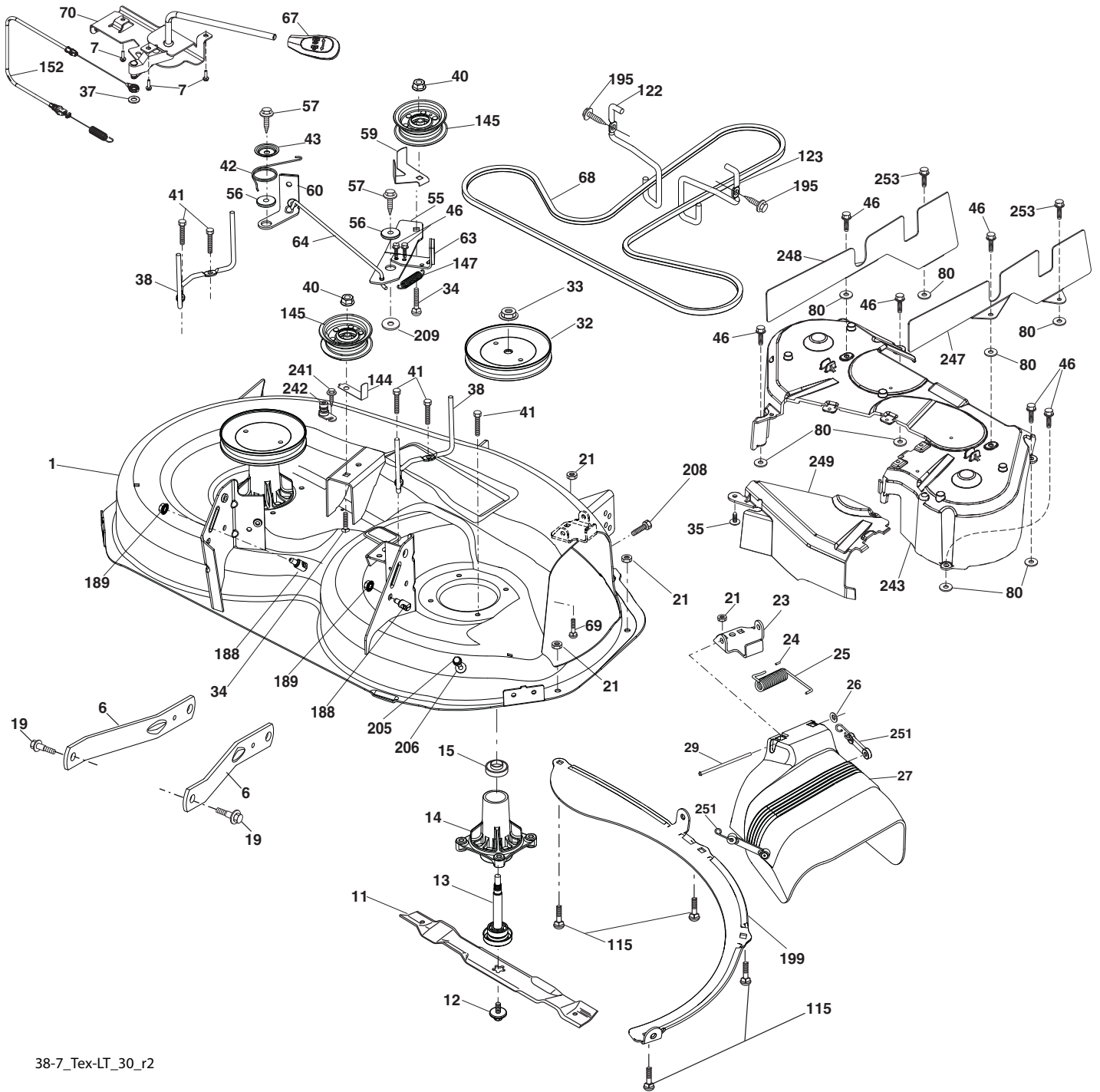

38-7_Tex-LT_30_r2

**TRACTOR - - MODEL NO. TS 38 (96041036601), PRODUCT NO. 960 41 03-66
MOWER DECK 44**

KEY NO.	PART NO.	DESCRIPTION	KEY NO.	PART NO.	DESCRIPTION
1	587 77 18-02	Mower Housing	70	532 40 12-46	Clutch Asm. Manual
6	532 19 51-86	Arm Suspension	80	532 42 30-62	Pal Nut
7	532 41 63-58	Screw #10 x BOS Thread	115	872 11 05-05	Bolt Carr. 5/16-18x5 18 Short
11	581 11 63-01	Blade 38"	122	532 19 72-58	Keeper Belt Engine LH
12	584 30 93-01	Screw Sems 7/16-20 x 1	123	532 19 72-59	Keeper Belt Engine RH
13	587 25 65-01	Shaft Assembly, Mandrel	144	532 19 34-14	Keeper Belt
14	532 18 72-81	Housing, Mandrel	145	532 19 31-97	Pulley, Idler, Flat
15	585 32 39-01	Bearing, Mandrel	147	532 40 18-72	Spring Return
19	532 19 65-39	Bolt, Shoulder	152	532 43 51-11	Manual Clutch Cable
21	873 68 05-00	Nut, Crownlock 5/16-18 unc	188	532 19 51-61	Stud Fastener
23	532 19 25-57	Bracket, Deflector	189	873 90 05-00	Nut Lock Hex Flange
24	532 10 53-04	Cap, Sleeve	195	817 00 06-12	Screw 3/8-16 x 3/4
25	532 19 70-26	Spring, Torsion, Deflector	199	532 40 00-95	Baffle Vortex
26	532 11 04-52	Nut, Push	205	817 49 04-16	Screw 1/4-20 x 1
27	532 40 16-18	Shield, Deflector	206	819 09 14-16	Washer 9/32 x 7/8 x 16 Ga.
29	532 13 14-91	Rod, Hinge	208	817 67 06-08	Screw 3/8-16 x 1/2
32	532 19 97-89	Pulley, Mandrel	209	819 13 32-10	Washer 13/32 x 2 x 10
33	532 40 02-34	Nut, Toplock, Flanged	241	532 15 29-27	Screw TT #10-32.5 3/8 Flange
34	872 11 06-12	Bolt Carr. Sh. 3/8-16 x 1-1/2 Gr. 5	242	532 41 55-98	Port Washout
35	532 13 38-35	Fastener, Christmas Tree	243	532 40 65-10	Cover Assy
37	819 13 13-16	Washer	247	532 43 02-58	Shield Deck RH Assy
38	532 19 95-41	Keeper Belt LH Mandrel	248	532 43 02-59	Shield Deck LH Assy
40	873 90 06-00	Nut, Lock Flg. 3/8-16 unc	249	532 40 65-14	Cover Cable Clutch
41	584 95 39-01	Bolt Hex	251	532 43 60-87	Kit Bungee (Includes Phillips head screw, weld nut, screw, bungee latch, and bungee strap)
42	532 19 84-10	Spring Torsion Brake			
43	532 19 72-56	Spring Torsion Retainer	253	532 42 73-50	Rivet
46	532 13 77-29	Screw 1/4-20 x 5/8	--	587 25 33-01	Mandrel Assembly (Includes housing, shaft and shaft hardware only-pulley not included)
55	532 19 72-49	Arm, Idler	--	532 44 33-58	Replacement Mower, Complete
56	532 19 90-92	Spacer, Retainer			
57	817 00 06-16	Screw 3/8-16 x 1			
59	532 14 10-43	Guard, Tuv. Idler			
60	532 19 94-71	Arm Brake Mower			
63	532 19 94-70	Arm Brake Mower			
64	532 19 97-90	Link Brake			
67	532 40 30-12	Handle Clutch Cable			
68	532 40 83-81	V-Belt			
69	872 14 05-05	Bolt			

NOTE: All component dimensions given in U.S. inches
1 inch = 25.4 mm

TRACTOR - - MODEL NO. TS 38 (96041036601), PRODUCT NO. 960 41 03-66
MOWER LIFT 45

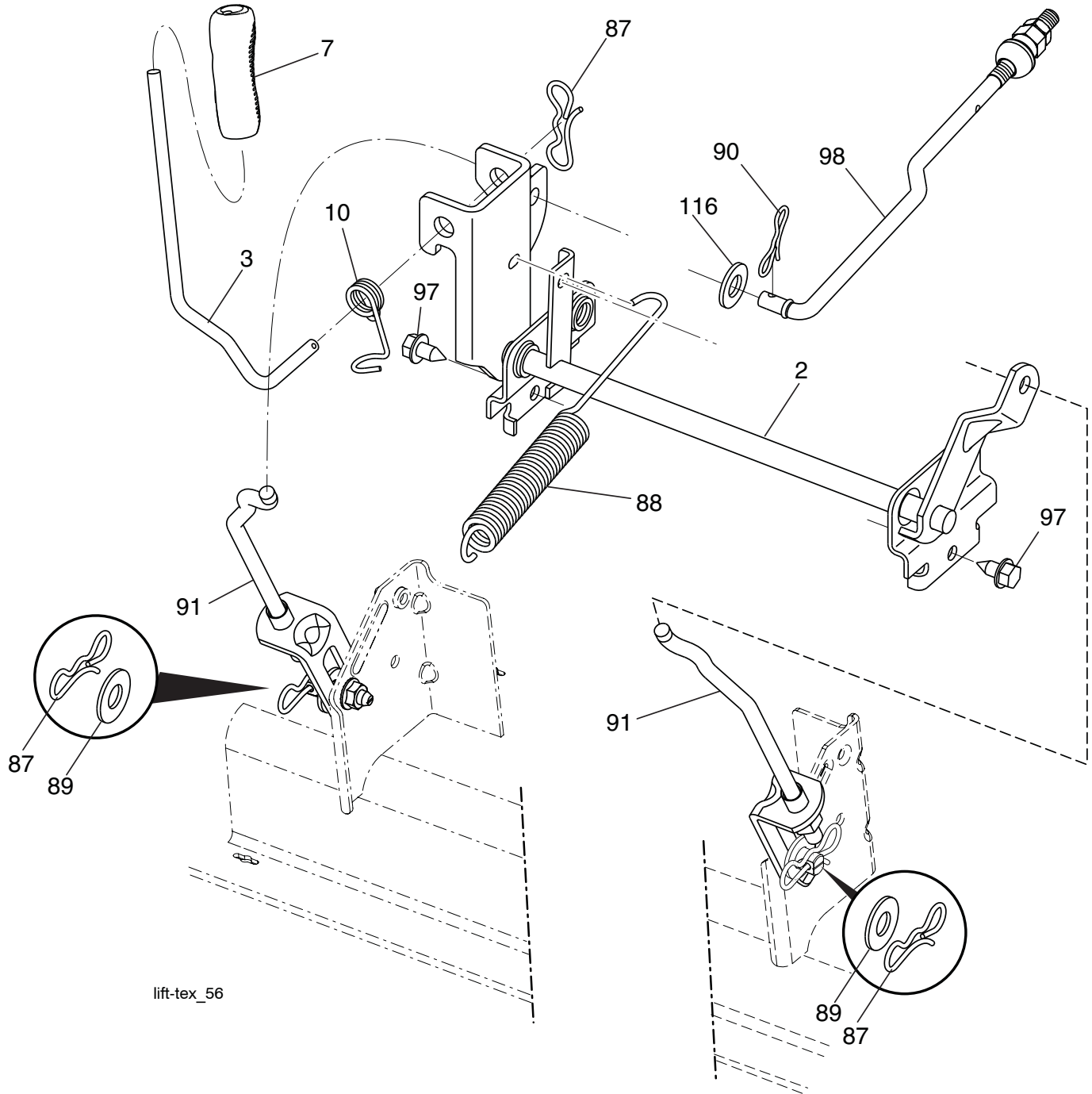

lift-tex_56

KEY NO.	PART NO.	DESCRIPTION
2	532 42 20-27	Shaft Asm., Lift
3	532 19 52-31	Lever Asm., Lift RH
7	580 96 23-01	Grip, Lever
10	532 19 63-14	Spring Torsion
87	532 19 42-09	Pin Cotter 7/16 Bow Tie Lock
88	532 41-07-10	Spring Lift Assist
89	819 19 19-12	Washer Clear Zinc
90	532 19 42-08	Pin Cotter 5/16 Bow Tie Lock

KEY NO.	PART NO.	DESCRIPTION
91	532 19 51-81	Link Lift Susp. Mower Rear
97	817 00 06-12	Screw 3/8-16 x .75 Smgml. Tap/R.Z
98	532 19 52-70	Link Lift Susp. Front Mower
116	819 15 15-16	Washer 15/32 x 15/16 x 16 Ga.

NOTE: All component dimensions given in U.S. inches
 1 inch = 25.4 mm

**TRACTOR - - MODEL NO. TS 38 (96041036601), PRODUCT NO. 960 41 03-66
SEAT ASSEMBLY 42**

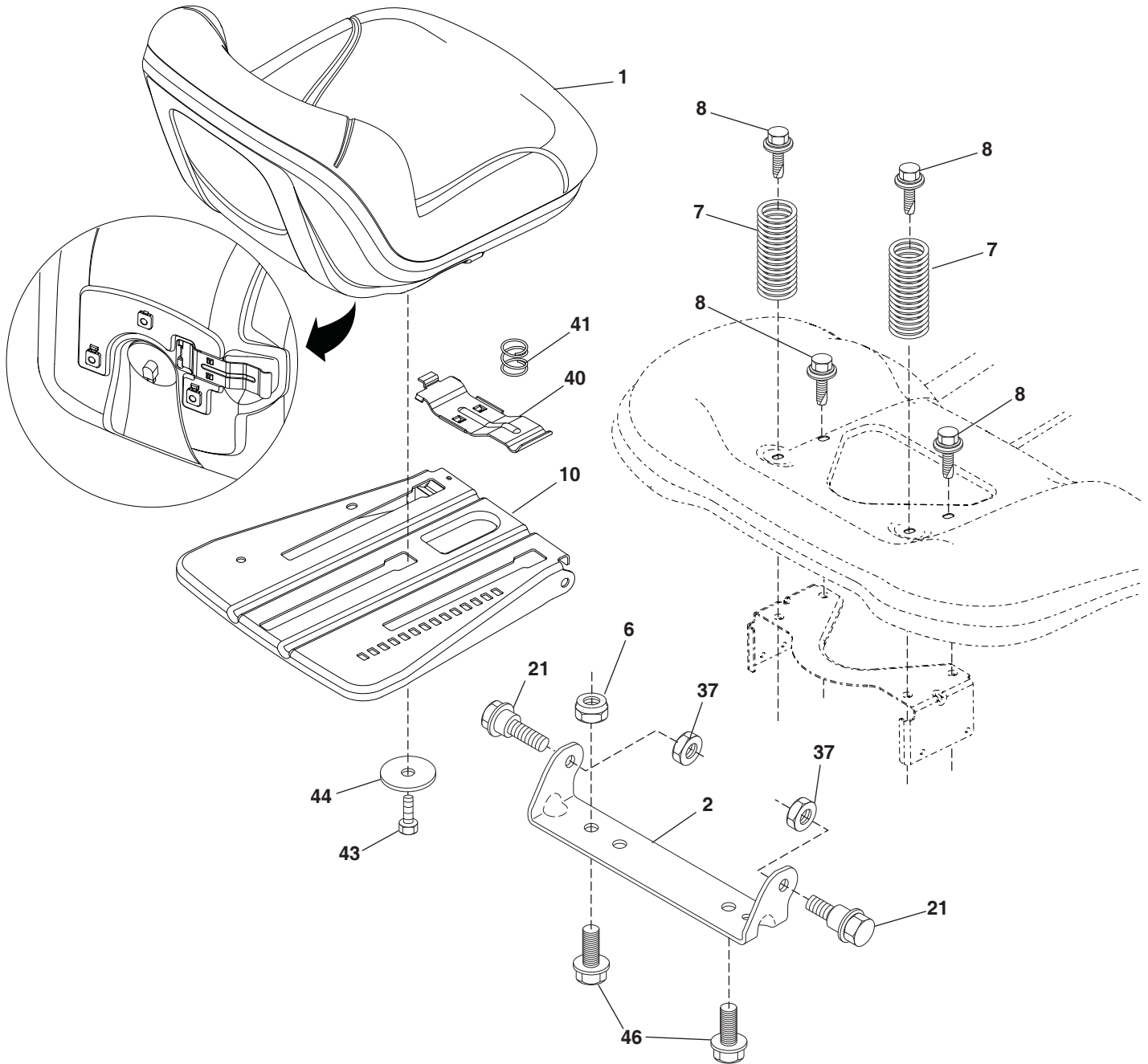

seat-tex_6.5SL_9

KEY NO.	PART NO.	DESCRIPTION
1	532 43 97-09	Seat
2	532 18 01-66	Bracket Pivot Fender
6	873 80 06-00	Nut, Lock w/Ins. 3/8-16 unc
7	587 61 33-01	Spring, Seat Cprsn.
8	532 17 18-77	Bolt 5/16-18 unc x 3/4 w/Sems.
10	532 19 69-77	Pan, Seat
21	587 90 78-01	Bolt 5/16-18 x 5/8
37	873 80 05-00	Nut, Lock 5/16-18 unc

KEY NO.	PART NO.	DESCRIPTION
40	532 19 76-61	Handle
41	532 19 82-00	Spring
43	874 76 06-12	Bolt 3/8-16 unc x 3/4
44	819 13 38-12	Washer 13/32 x 2-3/8 x 12 Ga.
46	588 09 04-01	Bolt 3/8-18 x 1

NOTE: All component dimensions given in U.S. inches
1 inch = 25.4 mm

