

ILLUSTRATED PARTS LIST

MODEL NO. 96061034301

CUST. CATALOG NO. CTH151T

PRODUCT NO. 960 61 03-43

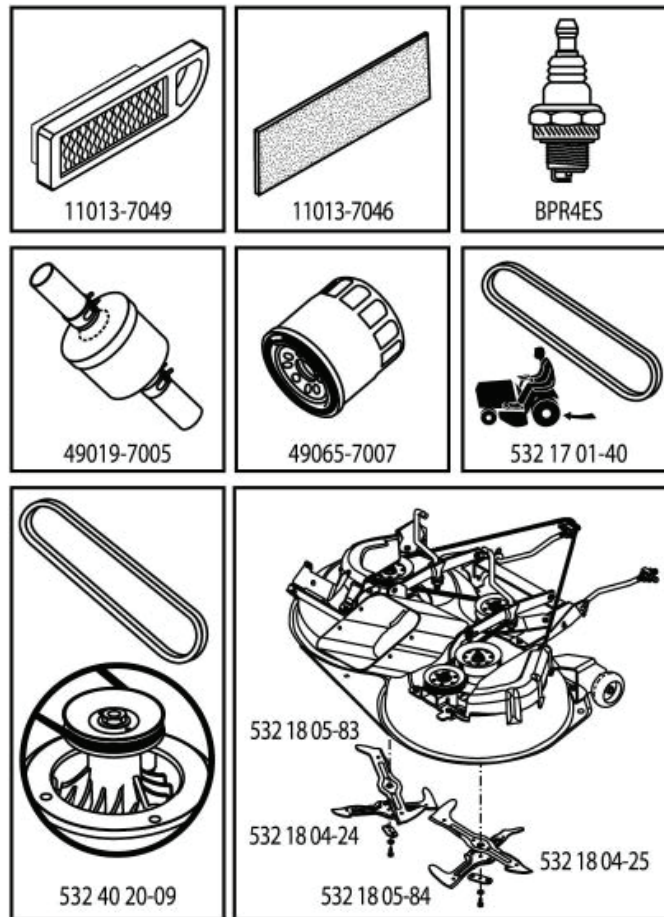

581276501

TRACTOR - MODEL NO. CTH151T (96061034301), PROD. NO. 960 61 03-43
DECALS 27

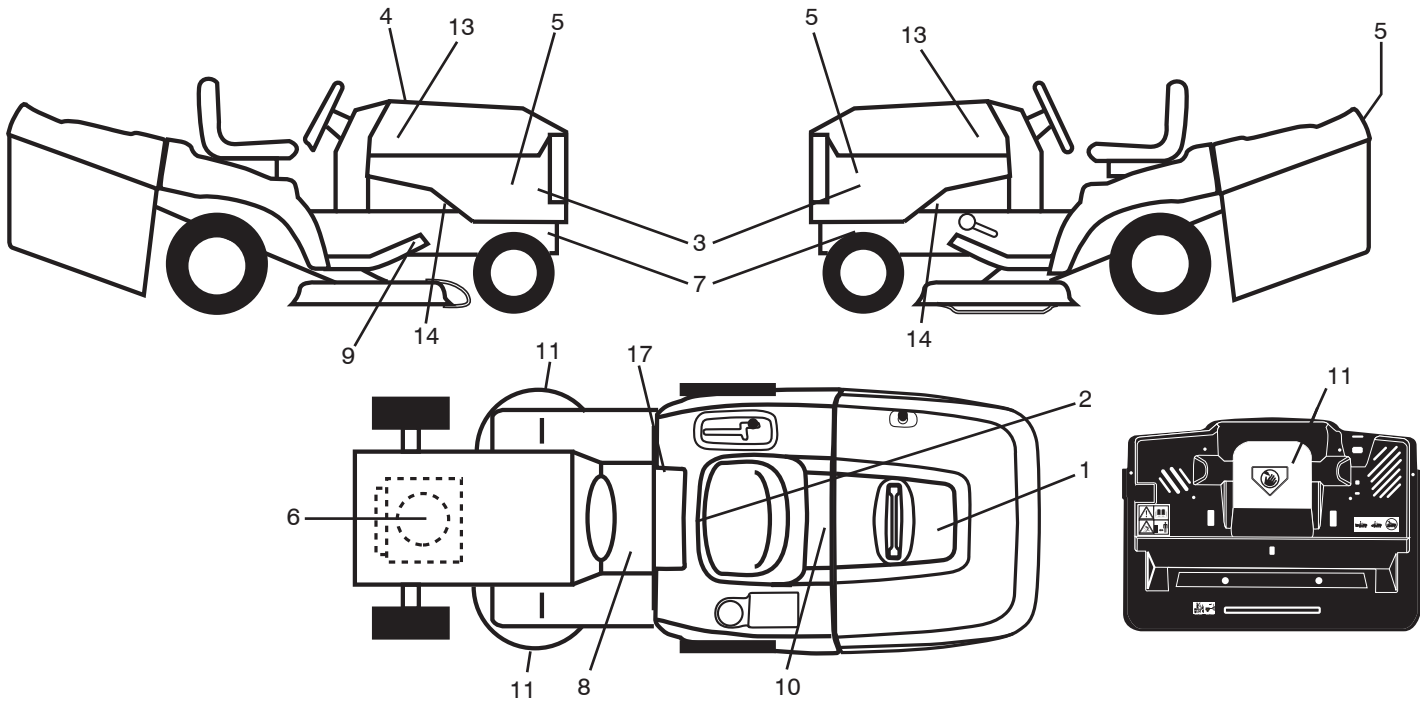

KEY NO.	PART NO.	DESCRIPTION
1	581 72 48-01	Decal Bypass Fender
2	581 57 81-01	Decal Warning Symbols CE
3	581 34 56-01	Decal Side Panel
4	581 27 65-01	Decal RPL
5	585 16 06-01	Decal Hood
6	581 57 97-01	Decal Engine Warning
7	581 57 98-01	Decal Warning Ser./Fire
8	581 72 40-01	Decal Brake/Clutch Symbol
9	581 58 00-05	Decal Hex Belt Sch.

KEY NO.	PART NO.	DESCRIPTION
10	532 14 50-05	Decal Bat Dan/Poi P/L Sym Wpn
11	581 57 91-01	Decal Mower Cut Finger Symbol
13	532 18 89-22	Decal Hood SV. Engine
14	581 57 96-01	Decal Chassis Hot Muffler
17	581 57 80-01	Decal Saddle Brake Parking
--	581 72 49-01	Decal Lift Handle
--	532 18 10-91	Pad Footrest LH
--	532 18 10-90	Pad Footrest RH
--	585 87 36-40	Manual Operator's (Euro)

WHEELS & TIRES

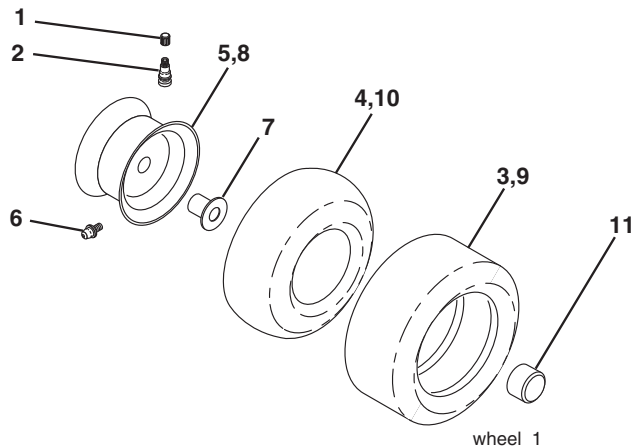

KEY NO.	PART NO.	DESCRIPTION
1	532 05 91-92	Cap Valve Tire
2	532 06 51-39	Stem Valve
3	532 10 62-22	Tire F Ts 15 x 6-6 Service
4	532 05 99-04	Tube Inner Front #35060
5	532 13 83-36	Rim Asm 6" Front Service
6	532 12 49-57	Fitting Grease
7	532 12 49-59	Bearing Flange
8	532 13 83-37	Rim Asm 8" Rear Service
9	532 12 20-82	Tire R Ts 20 x 10-8 Service
10	532 12 49-26	Tube Rear 9 5 x 8 Service
11	532 17 50-39	Cap Axle Blk 1 50 x 1 00
--	532 14 43-34	Sealant, Tire (10 oz. tube)

NOTE: All component dimensions given in U.S. inches.
 1 inch = 25.4 mm

TRACTOR - MODEL NO. CTH151T (96061034301), PROD. NO. 960 61 03-43

SCHEMATIC 38

SCH05

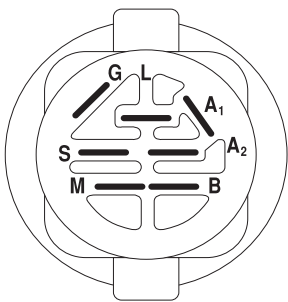
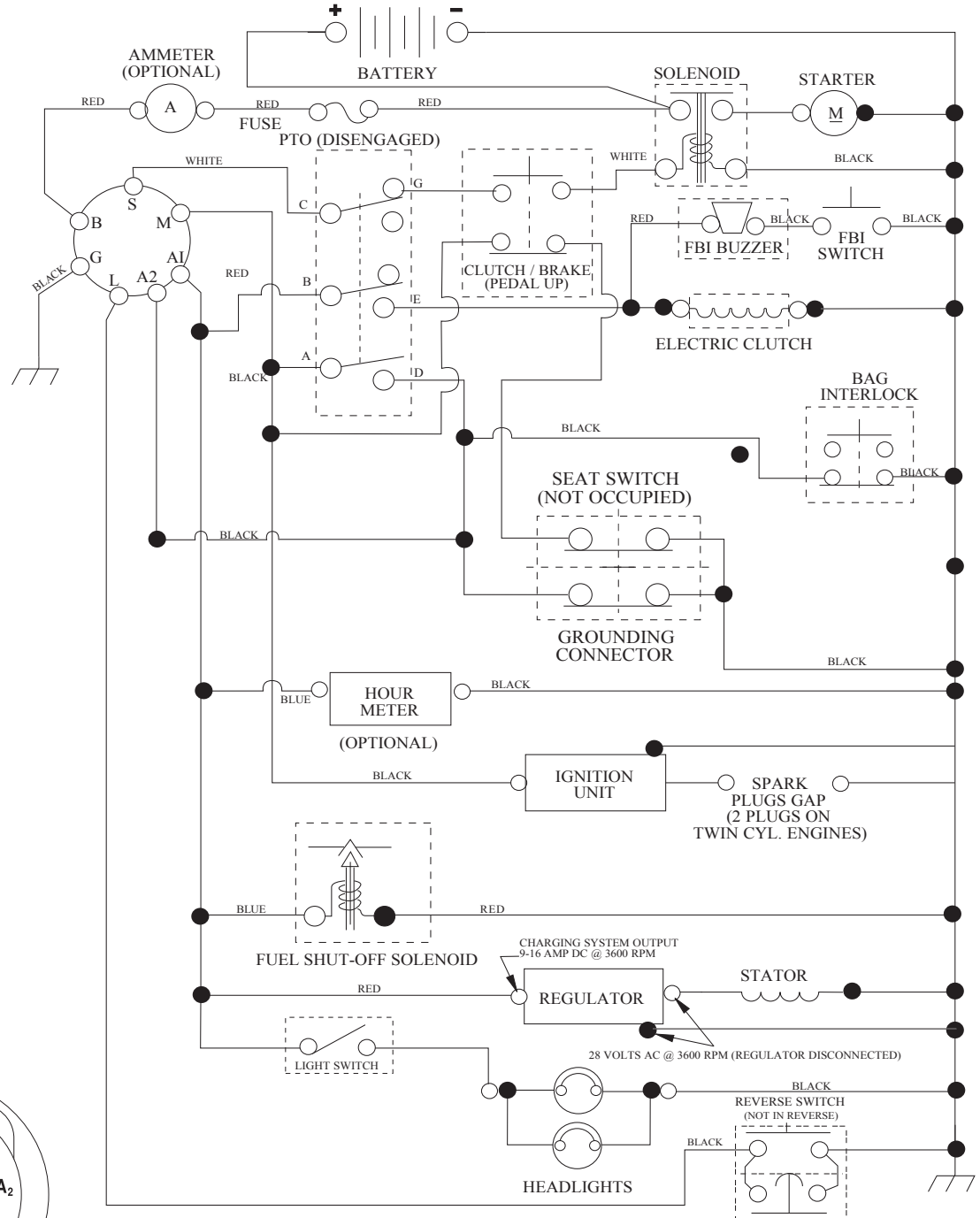

IGNITION SWITCH

POSITION	CIRCUIT	"MAKE"
OFF	M+G+A1	
RUN/OVERRIDE	B+A1	
RUN	B+A1	L+A2
START	B + S + A1	

03048

WIRING INSULATED CLIPS
NOTE: IF WIRING INSULATED CLIPS WERE REMOVED FOR SERVICING OF UNIT, THEY SHOULD BE RE-INSTALLED TO PROPERLY SECURE YOUR WIRING.

PTO SWITCH	
POSITION	CIRCUIT
OFF	C + G, B + H
ON	C + F, B + E, A + D



RELAY

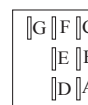

NON-REMOVABLE CONNECTIONS

REMOVABLE CONNECTIONS

TRACTOR - MODEL NO. CTH151T (96061034301), PROD. NO. 960 61 03-43
ELECTRICAL 32

C03

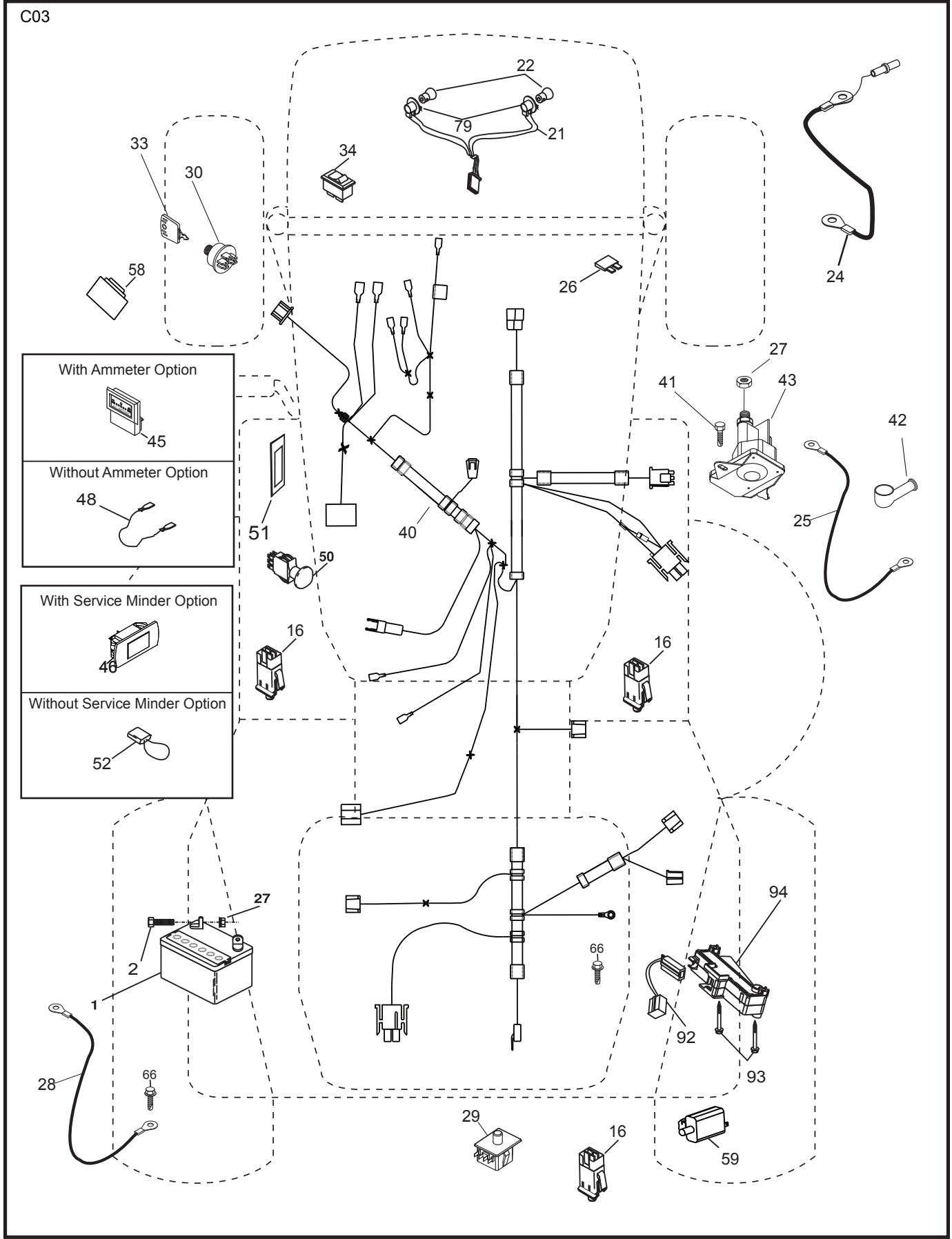

**TRACTOR - MODEL NO. CTH151T (96061034301), PROD. NO. 960 61 03-43
ELECTRICAL 32**

KEY NO.	PART NO.	DESCRIPTION
1	532 16 34-65	Battery
2	874 76 04-12	Bolt Hex Hd 1/4-20 unc x 3/4
16	532 17 61-38	Switch Interlock
21	532 17 56-88	Harness Light w/4152J
22	532 00 41-52	Bulb Light #1156
24	532 16 59-87	Cable Battery
25	532 42 12-99	Cable Starter
26	532 17 51-58	Fuse
27	873 51 04-00	Nut Keps Hex 1/4-20 unc
28	532 12 77-25	Cable Ground
29	532 19 27-49	Switch Seat
30	532 19 33-50	Switch Ignition
33	532 41 19-35	Key/Chain
34	532 11 07-12	Switch Light
40	532 19 74-34	Harness Ign
41	871 11 04-08	Bolt Flk Fin Hex 1/4-20 unc x 1/2
42	532 13 15-63	Cover Terminal Red
43	532 19 25-07	Solenoid
48	532 14 08-44	Adapter Ammeter Rectangular
50	532 17 46-51	Switch PTO
51	532 14 04-05	Ring Retainer PTO
52	532 14 19-40	Protection Wire Loop
58	532 16 94-19	Buzzer CRD
59	532 18 03-79	Switch FBI CRD
66	817 49 06-08	Screw Thdrol 3/8-16 x 1/2 Ty-Tt
79	532 17 52-42	Socket Asm. Bulb
92	532 19 66-15	Harness Pigtail
93	532 19 25-40	Screw Plastite 10-14 x 2.0
94	532 19 18-34	Module Reverse

NOTE: All component dimensions given in U.S. inches.
1 inch = 25.4 mm.

TRACTOR - MODEL NO. CTH151T (96061034301), PROD. NO. 960 61 03-43
CHASSIS AND ENCLOSURES **39**

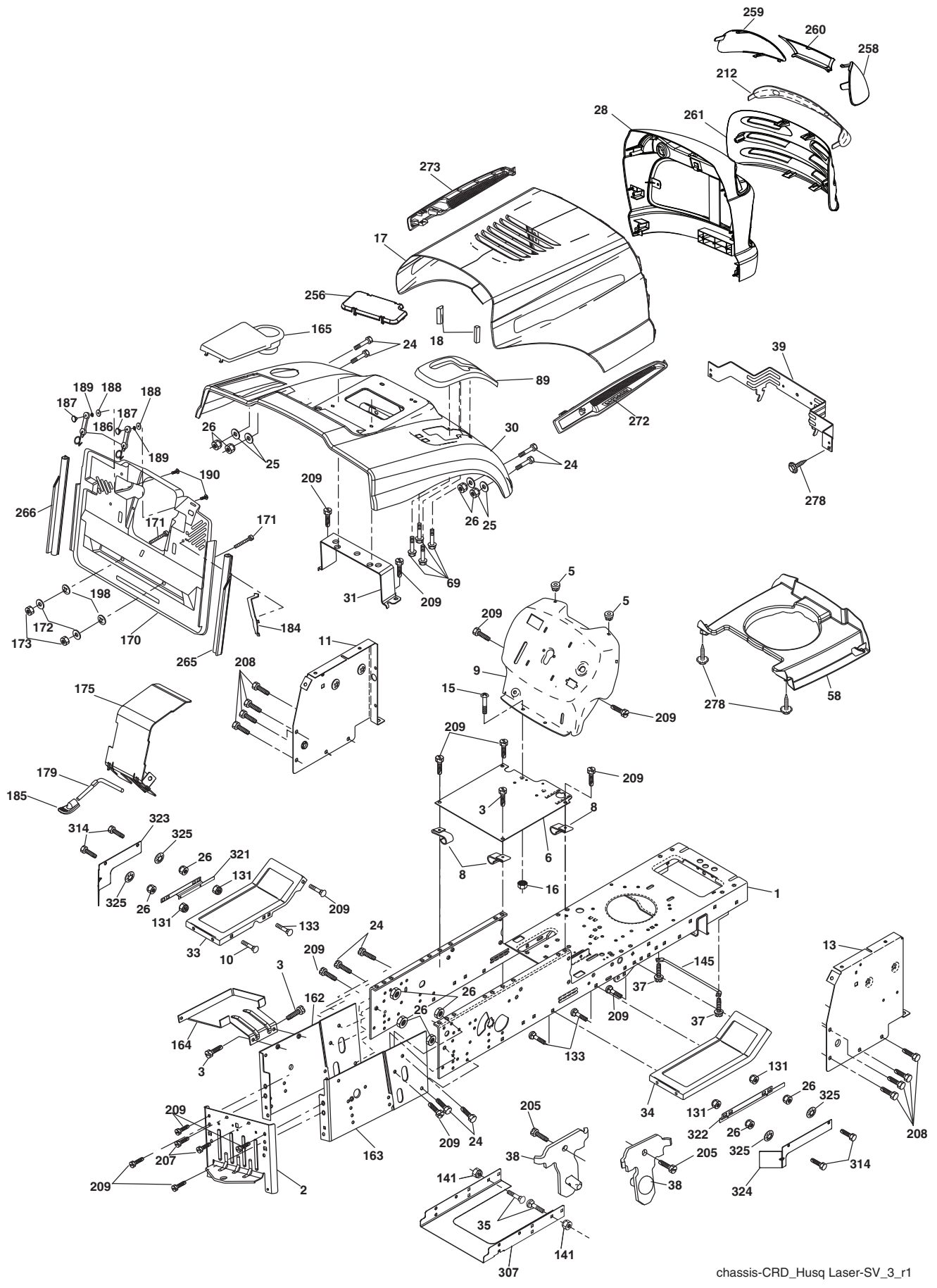

chassis-CRD_Husq Laser-SV_3_r1

**TRACTOR - MODEL NO. CTH151T (96061034301), PROD. NO. 960 61 03-43
CHASSIS AND ENCLOSURES 39**

KEY NO.	PART NO.	DESCRIPTION	KEY NO.	PART NO.	DESCRIPTION
1	532 17 46-20	Chassis	171	872 14 06-20	Bolt Rdhd Sqnk 3/8-16 x 2-1/2 Gr. 5
2	532 18 03-84	Drawbar	172	819 13 20-16	Washer 13/32 x 1-1/4 x 16 Ga.
3	817 06 06-12	Screw 3/8-16 x 3/4	173	873 51 06-00	Nut, Keps Hex 3/8-16 unc
5	532 15 52-72	Bumper Hood/Dash	175	532 18 82-03	Door Trap
6	532 18 44-19	Saddle	179	532 18 82-02	Rod Pivot FBI CRD
8	532 12 64-71	Clip Insulator 13/32 Mtg. Hole	184	532 17 46-62	Bracket Actuator Bagger CRD
9	532 19 52-52	Dash	185	532 44 14-16	Knob Rod Brake Parking
10	872 14 06-10	Bolt, Carriage 3/8-16 x 1 1/4	186	532 16 07-93	Latch Asm Mulch/Bagger
11	532 17 49-96	Panel, Dash, LH	187	532 12 50-04	Nut Weld
13	532 17 21-06	Panel, Asm. Dash RH	188	819 06 12-16	Washer #10
15	874 18 05-12	Screw, Machine, Truss Head 5/16-18 unc x 3/4	189	810 07 10-00	Washer Lock #10
16	873 51 05-00	Nut	190	871 08 10-10	Screw Pan Hd Phillip 10-24 x 5/8
17	532 44 29-23	Hood	198	532 16 89-37	Nut, Push
18	532 18 49-21	Bumper Hood	205	817 49 06-08	Screw Thdrol 3/8-16 x 1/2
24	874 78 06-16	Bolt	207	817 67 05-08	Screw Thdrl. 5/16-18 x 1/2
25	819 13 13-12	Washer 13/32 x 13/16 x 12 Ga.	208	817 67 06-08	Screw Thdrol 3/8-16 x 1/2
26	873 80 06-00	Nut	209	817 00 06-12	Screw Hex Wsh Thdrol 3/8-16
28	532 44 22-03	Grille	212	532 18 35-48	Insert Lens Reflect
30	532 44 12-65	Fender	256	532 18 13-61	Cover Fender Rack
31	532 16 51-56	Bracket, Fender Support	258	532 18 52-14	Lens RH
33	532 44 25-78	Footrest, LH	259	532 18 52-13	Lens LH
34	532 44 25-79	Footrest, RH	260	532 44 22-02	Cover Lens
35	872 11 06-06	Bolt	261	532 44 22-01	Insert Grille
37	817 49 05-08	Screw Thdrol 5/16-18 x 1/2 TYT	265	532 18 57-04	Seal RH Side Bagger
38	532 18 17-48	Bracket Asm Pivot Mower Rear	266	532 18 57-03	Seal LH Side Bagger
39	532 40 78-07	Bracket Pivot	272	532 44 22-00	Vent Hood RH
58	532 18 45-38	Duct Air Engine	273	532 44 21-99	Vent Hood LH
69	532 14 24-32	Screw HxWsh Hi-Lo	278	532 41 63-58	Screw #10 x .750 BOS Thread
89	532 44 15-74	Console CRD	307	532 44 18-40	Shield Chassis Front
131	873 22 06-00	Nut Fin Hex 3/8-16 unc	314	817 60 04-06	Screw Hex Washhead 1/4-20 x 3/8
133	872 11 06-08	Bolt Rdhd. Sqnk. 3/8-16 x 1 Gr. 5	321	532 43 03-09	Shield Deck Inner LH
141	873 90 06-00	Nut Lock 3/8-16 unc	322	532 43 10-14	Shield Deck Inner RH
145	532 40 91-67	Rod Pivot Chassis/Hood	323	532 43 24-00	Assy. LH Outside Deck
162	532 18 03-82	Bracket Exten Chassis LH CRD	324	532 43 24-01	Assy. RH Outside Deck
163	532 18 03-83	Bracket Exten Chassis RH CRD	325	532 42 30-62	Palnut 1/4
164	532 16 56-05	Support Battery CRD			
165	532 44 15-16	Cover Battery			
170	532 19 94-88	Backplate CRD			

NOTE: All component dimensions given in U.S. inches.
1 inch = 25.4 mm.

TRACTOR - MODEL NO. CTH151T (96061034301), PROD. NO. 960 61 03-43
DRIVE **40**

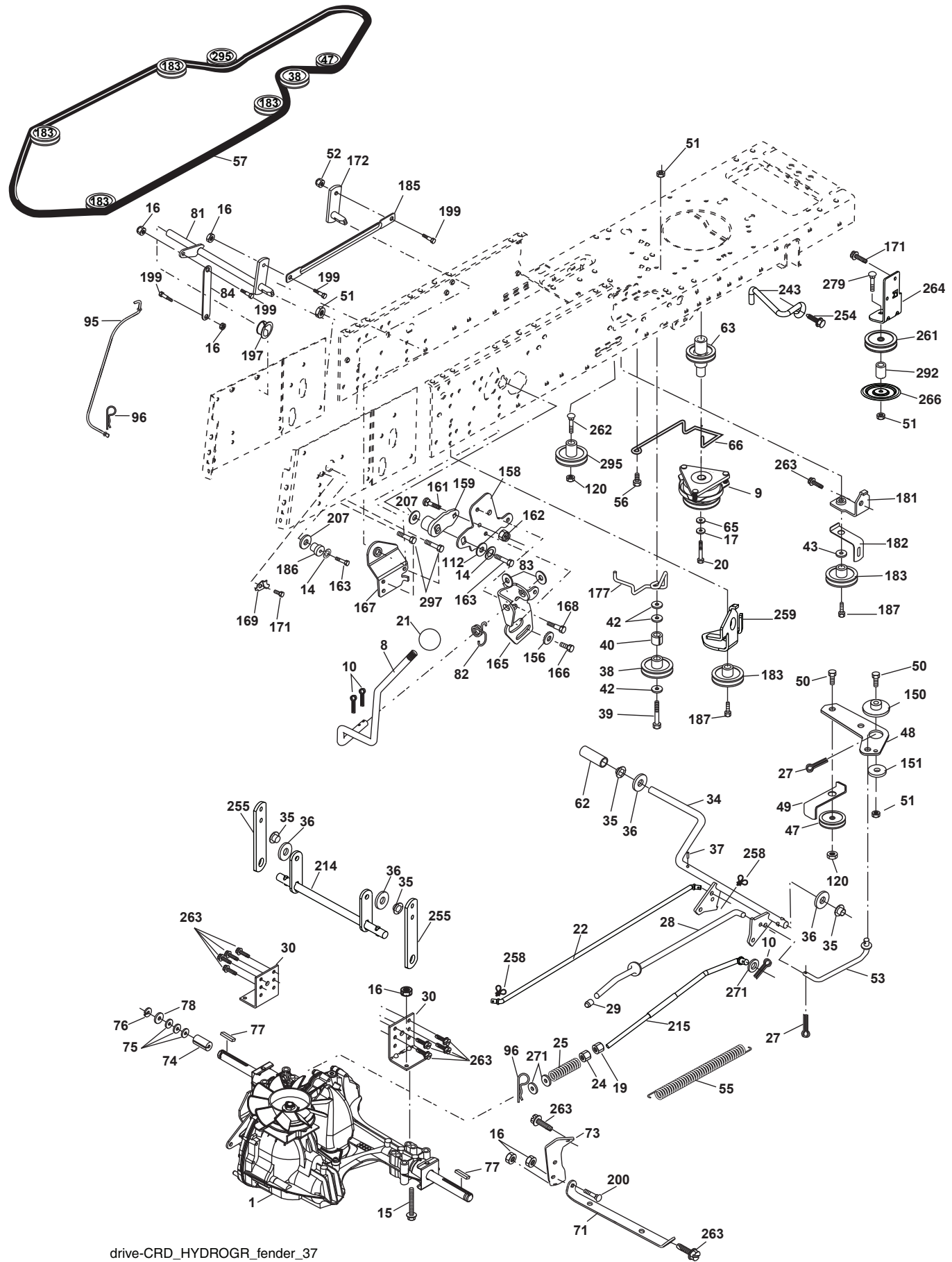

drive-CRD_HYDROGR_fender_37

TRACTOR - MODEL NO. CTH151T (96061034301), PROD. NO. 960 61 03-43
DRIVE 40

KEY NO.	PART NO.	DESCRIPTION	KEY NO.	PART NO.	DESCRIPTION
1	---	Transaxle Hydro Gear 321-0510 (170061) (Order parts from transaxle manufacturer.)	84	532 17 00-07	Link, Transaxle
8	532 19 27-06	Rod, Shift Fender Adjust LT	95	532 17 00-15	Control Asm Bypass Hydro
9	532 19 81-43	Clutch	96	532 12 47-88	Spring, Retainer 1"
10	876 02 04-16	Pin, Cotter 1/8 x 1	112	819 09 12-10	Washer 9/32 x 3/4 x 10 Ga.
14	810 04 04-00	Washer, Lock Hvy Helical	120	873 90 06-00	Nut Lock Flg. 3/8-16 unc
15	874 49 05-44	Bolt Hex FGHD 5/16-18 x Gr. 5	150	532 16 58-50	Bushing, Bellcrank Grnd Dr
16	873 80 05-00	Nut Lock Hex w/lns 5/16-18 unc	151	819 13 32-10	Washer 13/32 x 2 x 10 Ga.
17	532 12 61-97	Washer	156	532 16 60-02	Washer Srrted 5/16 ID x 1.125
19	873 80 06-00	Nut Lock Hex w/lns 3/8-16 unc	158	532 43 74-58	Bracket Shift Mount
20	532 17 39-37	Bolt	159	532 44 43-04	Hub Shift
21	532 12 12-74	Knob	161	872 14 04-06	Bolt Rdhd Sqnk 1/4-20 x 3/4 Gr. 5
22	532 17 56-07	Rod, Brake	162	873 68 04-00	Nut Crownlock 1/4-20 unc
24	873 35 06-00	Nut	163	874 78 04-16	Bolt Hex Fin 1/4-20 unc x 1 Gr. 5
25	532 19 20-36	Spring, Rod, Brake	165	532 43 82-50	Bracket Pivot Lever
27	876 02 04-12	Pin, Cotter 1/8 x 3/4	166	817 49 05-10	Screw 5/16-18 x 5/8
28	532 17 57-65	Rod, Parking Brake	167	532 16 55-88	Bracket Support Shift CRD
29	532 07 16-73	Cap, Parking Brake	168	532 16 54-92	Bolt Shoulder 5/16-18 x .561
30	532 16 95-92	Bracket, Mfg. Transaxle	169	532 16 55-80	Plate Fastening Lt
34	532 17 55-78	Shaft, Asm Pedal Foot CRD	171	817 49 06-08	Screw Thdrol 3/8-16 x 1/2 Ty-Tt
35	532 12 01-83	Bearing, Nylon	172	532 17 02-71	Shaft Asm Shifter Frt CRD
36	819 21 16-16	Washer 21/32 x 1 x 16 Ga.	177	532 16 59-32	Keeper Flat Idler 3.06" CRD
37	532 12 49-63	Pin, Roll 3/16 x 1"	181	532 18 02-11	Bracket Idler Ground Drive CRD
38	532 16 59-36	Pulley Flat Composite 3.06"	182	532 18 26-82	Keeper Belt 2.5" Od V-Idler CRD
39	874 76 06-44	Bolt Fin Hex 3/8-16 unc x 2-3/4	183	532 19 95-34	Pulley V-Idler CRD
40	532 12 49-65	Spacer, Split 395 x 59 Bzp	185	532 17 00-08	Link Shift
42	819 13 13-12	Washer 13/32 x 13/16 x 12 Ga.	186	532 16 56-14	Hub Tapered Round CRD
43	819 11 10-12	Washer 11/32 x 5/8 x 12 Ga.	187	817 58 05-20	Screw Thdrol 5/16-18 x 1.25
47	532 12 77-83	Pulley, Idler, V Groove Plastic	197	532 16 96-13	Nyliner Snap-In 5/8
48	532 15 44-07	Bellcrank Clutch Grnd Drv	199	532 16 96-12	Bolt Shoulder 5/16-18 unc
49	532 12 32-05	Retainer, Belt Style Spring	200	872 14 05-08	Bolt RDHD SQNK 5/16-18 x 1
50	872 11 06-12	Bolt Carr. Sh. 3/8-16 x 1-1/2 Gr. 5	207	532 16 98-45	Washer Nylon Rear
51	873 68 06-00	Nut, Crownlock 3/8-16 unc	214	532 17 56-09	Shaft Asm. Brake
52	873 68 05-00	Nut, Crownlock 5/16-18	215	532 17 56-52	Rod Brake Hydro
53	532 19 96-52	Link, Clutch 7.66	243	532 19 07-36	Bracket Anti-Rotation
55	532 10 57-09	Spring, Return, Clutch	254	817 00 06-16	Screw 3/8-16 x 1
56	817 06 06-20	Screw 3/8-16 x 1-1/4	255	532 17 56-08	Brace Shaft Brake Mtg.
57	532 17 01-40	V-Belt Kev 112" 0650 CRD	258	532 17 80-62	Clip Retainer
62	532 12 48-72	Cover, Pedal	259	532 18 02-12	Bracket Pulley
63	532 18 03-97	Pulley Engine	261	532 13 14-94	Pulley Idler
65	810 04 07-00	Washer	262	872 11 06-22	Bolt Rdhd 3/8-16 unc x 2-3/4 Gr. 5
66	532 15 47-78	Keeper, Belt Engine F-Proof	263	817 00 06-12	Screw 3/8-16 x 3/4
71	532 16 91-83	Strap, Torque, LH	264	532 43 11-72	Bracket Idler Chassis
73	532 16 91-82	Strap, Torque, RH	266	532 18 20-61	Shield Idler Mower
74	532 13 70-57	Spacer, Split	271	819 13 14-16	Washer 13/32 x 7/8 x 16 Ga.
75	532 12 17-49	Washer 25/32 x 1-1/4 x 16 Ga.	279	872 11 06-16	Bolt
76	812 00 00-01	Ring, E	292	532 40 02-71	Spacer Noram
77	532 12 35-83	Key, Square	295	532 17 91-14	Pulley Idler Composite
78	532 12 17-48	Washer 25/32 x 1-5/8 x 16 Ga.	297	817 49 06-10	Screw 3/8-16 x 5/8
81	532 17 00-06	Asm, Shaft, Cross Rear			
82	532 16 57-11	Spring, Torsion			
83	819 17 12-16	Washer 17/32 x 3/4 x 16 Ga.			

NOTE: All component dimensions given in U.S. inches
1 inch = 25.4 mm

**TRACTOR - MODEL NO. CTH151T (96061034301), PROD. NO. 960 61 03-43
ENGINE 24**

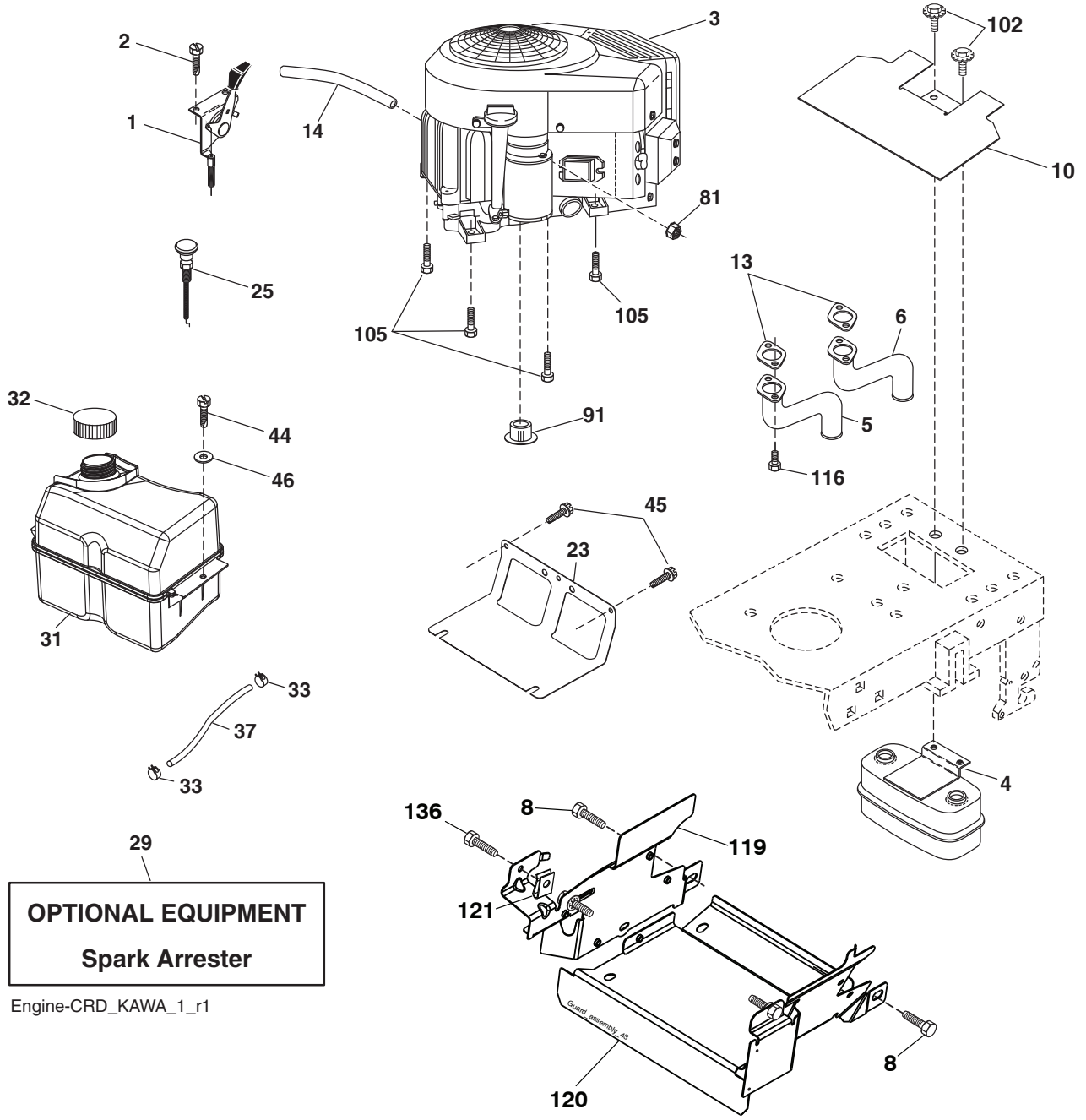

OPTIONAL EQUIPMENT
Spark Arrester

Engine-CRD_KAWA_1_r1

**TRACTOR - MODEL NO. CTH151T (96061034301), PROD. NO. 960 61 03-43
ENGINE 24**

KEY NO.	PART NO.	DESCRIPTION
1	532 19 04-54	Control Throt Flag
2	817 72 04-08	Screw Hex Thd Cut 1/4-20 x 1/2
3	- - - - -	KAWA FS481V-CS53 (445365) (Order parts from engine manufacturer.)
4	532 14 97-23	Muffler Exhaust
5	532 42 47-65	Exhaust Tube LH
6	532 42 47-66	Exhaust Tube RH
8	532 17 18-77	Bolt 5/16-18 x 3/4 w/Sems
10	532 43 40-17	Shield Heat Muffler
13	532 17 81-51	Gasket
14	532 14 84-56	Tube Drain Oil Easy
23	532 16 98-37	Shield Browning/Debris Guard
25	532 19 17-17	Control Choke
29	532 13 71-80	Arrester Spark
31	532 43 08-25	Tank Fuel
32	532 43 02-20	Cap Asm Fuel
33	532 12 34-87	Clamp Hose Blk
37	532 13 70-40	Line Fuel 20"
44	817 67 04-12	Screw Hexwsh Thdrol 1/4-20 x 3/4
45	817 00 06-12	Screw Hexwsh Thdr 3/8-16 x 3/4
46	819 09 14-16	Washer 9/32 x 7/8 x 16ga
81	873 51 04-00	Nut Keps 1/4-20 unc
91	532 18 74-95	Bushing
102	817 00 05-12	Screw 5/16-18 x 3/4
105	817 12 06-16	Screw 3/8-16 x 1
116	532 18 43-62	Nut Hex Flange Top Lock M8-1.25
119	532 19 97-68	Guard Asm. Engine LH CRD
120	532 19 97-67	Guard Asm. Engine RH CRD
121	532 19 66-88	Clips Threaded
136	532 13 77-29	Screw 1/4 - 20 x 5/8

NOTE: All component dimensions given in U.S. inches.
1 inch = 25.4 mm

TRACTOR - MODEL NO. CTH151T (96061034301), PROD. NO. 960 61 03-43
STEERING ASSEMBLY 41

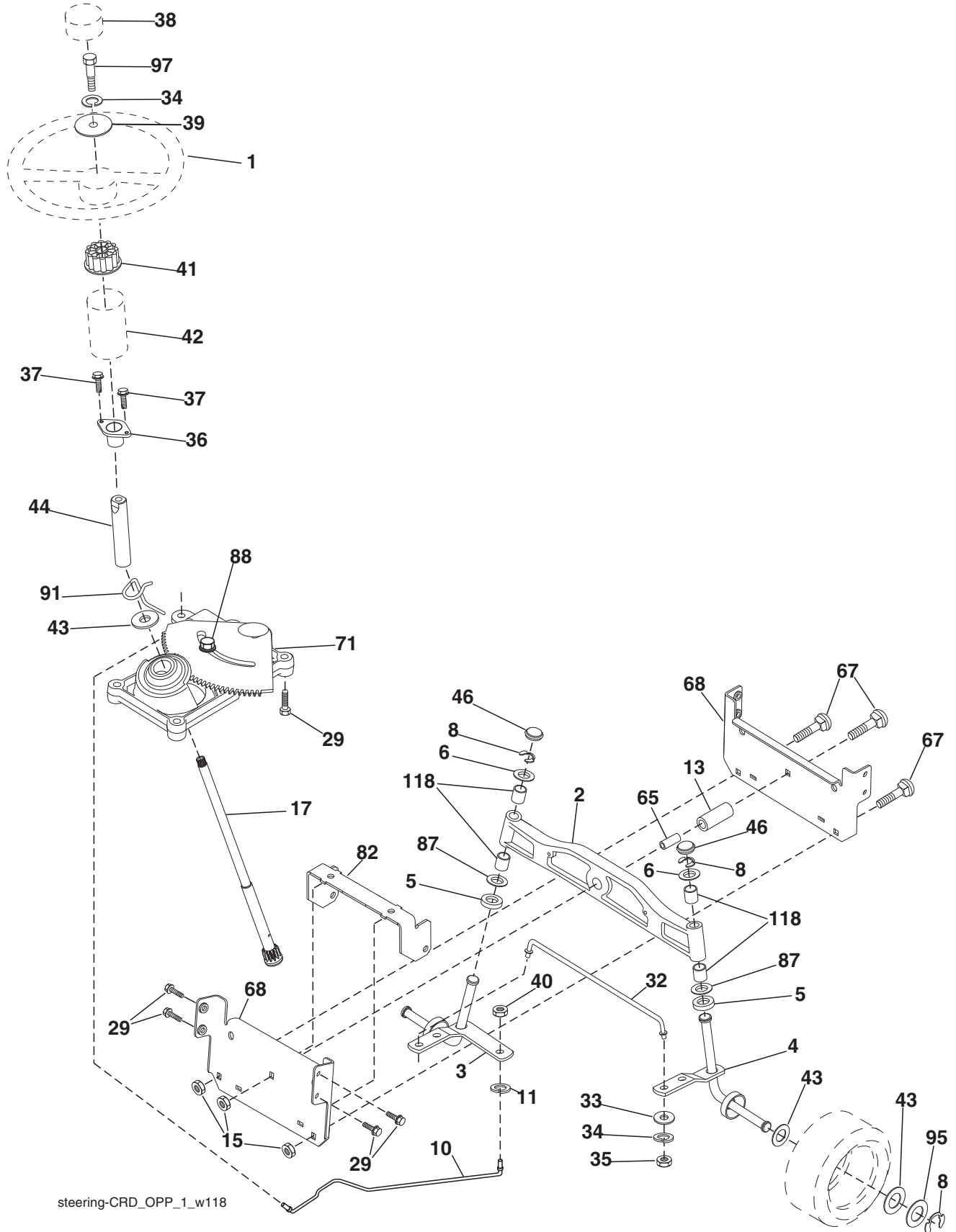

steering-CRD_OPP_1_w118

TRACTOR - MODEL NO. CTH151T (96061034301), PROD. NO. 960 61 03-43
STEERING ASSEMBLY 41

KEY NO.	PART NO.	DESCRIPTION
1	532 18 67-80	Steering Wheel
2	532 19 35-42	Axle Asm Cast Iron LT
3	532 16 98-40	Spindle Assembly, LH
4	532 16 98-39	Spindle Assembly, RH
5	532 12 49-31	Bearing, Race, Thrust, Hardened
6	532 12 17-48	Washer 25/32 x 1-5/8 x 16 Ga.
8	812 00 00-29	Ring, Clip
10	532 17 51-21	Link, Drag
11	810 04 06-00	Washer, Lock
13	532 13 65-18	Spacer Brg Axle Front
15	873 90 06-00	Nut Lock Flange 3/8-16 unc
17	532 19 07-53	Shaft, Steering
29	817 00 06-12	Screw 3/8-16 x 3/4
32	532 17 18-88	Rod, Tie
33	819 11 12-16	Washer 11/32 x 3/4 x 16 Ga.
34	810 04 05-00	Washer Lock Hvy Hlcl Spr 5/16
35	873 54 05-00	Crownlock Nut 5/16-24 unf 3847
36	532 15 50-99	Bushing, Steering
37	532 15 29-27	Screw TT #10-32 x 5 x 3/8 Flange
38	532 19 29-16	Cap Wheel Steering
39	819 11 38-12	Washer 11/32 ID x 2- 3/8 OD x 12 Ga.
40	810 04 05-00	Nut Lock 3/8-24
41	532 18 67-37	Adaptor, Steering Wheel
42	532 16 96-33	Boot, Steering Dash
43	532 12 17-49	Washer 25/32 x 1-1/4 x 16 Ga.
44	532 19 07-52	Extension Steering Shaft
46	532 12 12-32	Cap, Spindle
65	532 41 47-36	Spacer Brace Axle
67	872 11 06-18	Bolt Rdhd Sqnk 3/8-16 x 2-1/4
68	532 16 98-27	Brace Axle
71	532 17 51-46	Steering Asm.
82	532 19 99-78	Bracket Susp Chassis Front
87	532 17 39-66	Washer Flat .781 x 1 1/2 x .14
88	532 17 51-18	Bolt Shoulder 7/16-20 unc
91	532 17 55-53	Clip Steering
95	532 18 89-67	Washer
97	532 42 89-82	Bolt Fin Hex 5/16-18 x 4 w/Patch
118	532 40 60-13	Bushing Axle

NOTE: All component dimensions given in U.S. inches.
1 inch = 25.4 mm.

TRACTOR - MODEL NO. CTH151T (96061034301), PROD. NO. 960 61 03-43
MOWER DECK 44

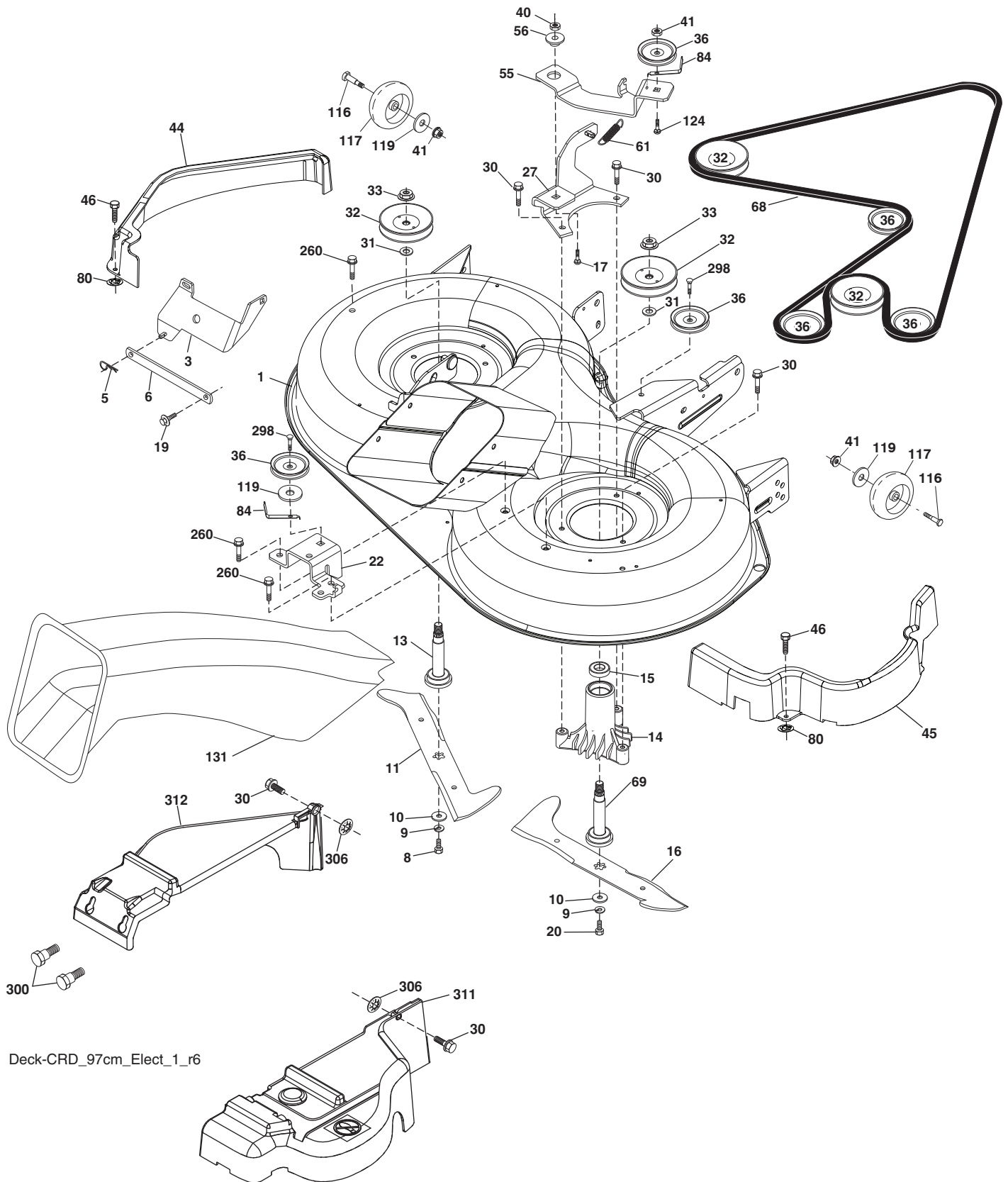

Deck-CRD_97cm_Elect_1_r6

**TRACTOR - MODEL NO. CTH151T (96061034301), PROD. NO. 960 61 03-43
MOWER DECK 44**

KEY NO.	PART NO.	DESCRIPTION	KEY NO.	PART NO.	DESCRIPTION
1	532 42 91-21	Housing Asm. Mower	68	532 42 95-32	Drive Belt
3	532 43 18-64	Bracket Asm. S-Bar Chass	69	532 16 54-82	Shaft Asm w/Lwr Brg RH Thd
5	532 12 46-70	Retainer Spring	80	532 42 30-62	Palnut 1/4
6	532 16 55-57	Bar Sway	84	532 15 60-85	Keeper Belt Idler
8	532 18 17-12	Bolt 3/8-24 x 1.25 Gr. 8 Patched	116	532 19 34-06	Bolt Shoulder
9	810 03 06-00	Washer Lock Hvy 3/8 Unplated	117	532 17 48-73	Wheel Gauge
10	532 14 02-96	Washer Hard Blade Mower Vented	119	819 13 20-12	Washer 13/32 x 1-1/4 x 12 Ga.
11	532 42 79-84	Blade 3-1 LH	124	872 11 06-12	Bolt Carr Sh 3/8-16 x 1-1/2 Gr. 5
13	532 13 76-45	Shaft Asm. w/Lower Bearing	131	532 16 56-61	Chute Bagger
14	532 12 87-74	Housing Mandrel Vented (Machd)	260	817 67 06-08	Screw 3/8-16 x 1/2
15	532 11 04-85	Bearing Ball Mandrel	298	817 49 06-28	Screw 3/8-16 x 1-3/4
16	532 42 79-85	Blade 3-1 RH	300	532 19 65-39	Bolt Shoulder
17	872 14 06-10	Bolt Carriage 3/8-16 x 1-1/4	306	532 42 30-63	Palnut 5/16
19	532 13 28-27	Bolt Shoulder 5/16-18 Thd Form	311	532 43 07-74	Cover Mandrel RH
20	532 18 17-13	Bolt 3/8-24 x 1.25 Gr. 8 Ptch Lhthd	312	532 43 07-75	Cover Mandrel LH
22	532 43 11-69	Bracket Idler Sprt Rear RH	--	532 18 18-57	Mandrel Assembly (Includes housing, shaft assembly, and bearing only - pulley/nut/washer and blade bolt/washers not included)
27	532 42 79-81	Bracket Asm. Susp. Rear RH	--	532 18 18-58	Mandrel Asm CRD LH Threads SVC
30	532 17 39-84	Screw Thd Rolling	--	532 43 17-83	Replacement Mower, Complete (Std. Deck - Order separately gauge wheel components key nos. 116-119)
31	532 18 76-90	Washer Spacer Mower Vented			
32	532 15 35-32	Mandrel Pulleys			
33	532 40 02-34	Nut Flg Top Lock			
36	532 14 67-63	Pulley Idler V-Groove Dim 4.25			
40	873 68 06-00	Nut Crownlock 3/8-16 unc			
41	873 90 06-00	Nut Lock Flg. 3/8-16 unc			
44	532 43 02-10	Cover Mandrel LH			
45	532 43 02-09	Cover Mandrel RH			
46	532 13 77-29	Screw 1/4-20 x 5/8			
55	532 19 94-98	Arm Idler			
56	532 16 57-23	Spacer Retainer Mower			
61	532 19 94-86	Spring Tension Belt			

NOTE: All component dimensions given in U.S. inches
1 inch = 25.4 mm

TRACTOR - MODEL NO. CTH151T (96061034301), PROD. NO. 960 61 03-43
SEAT ASSEMBLY 42

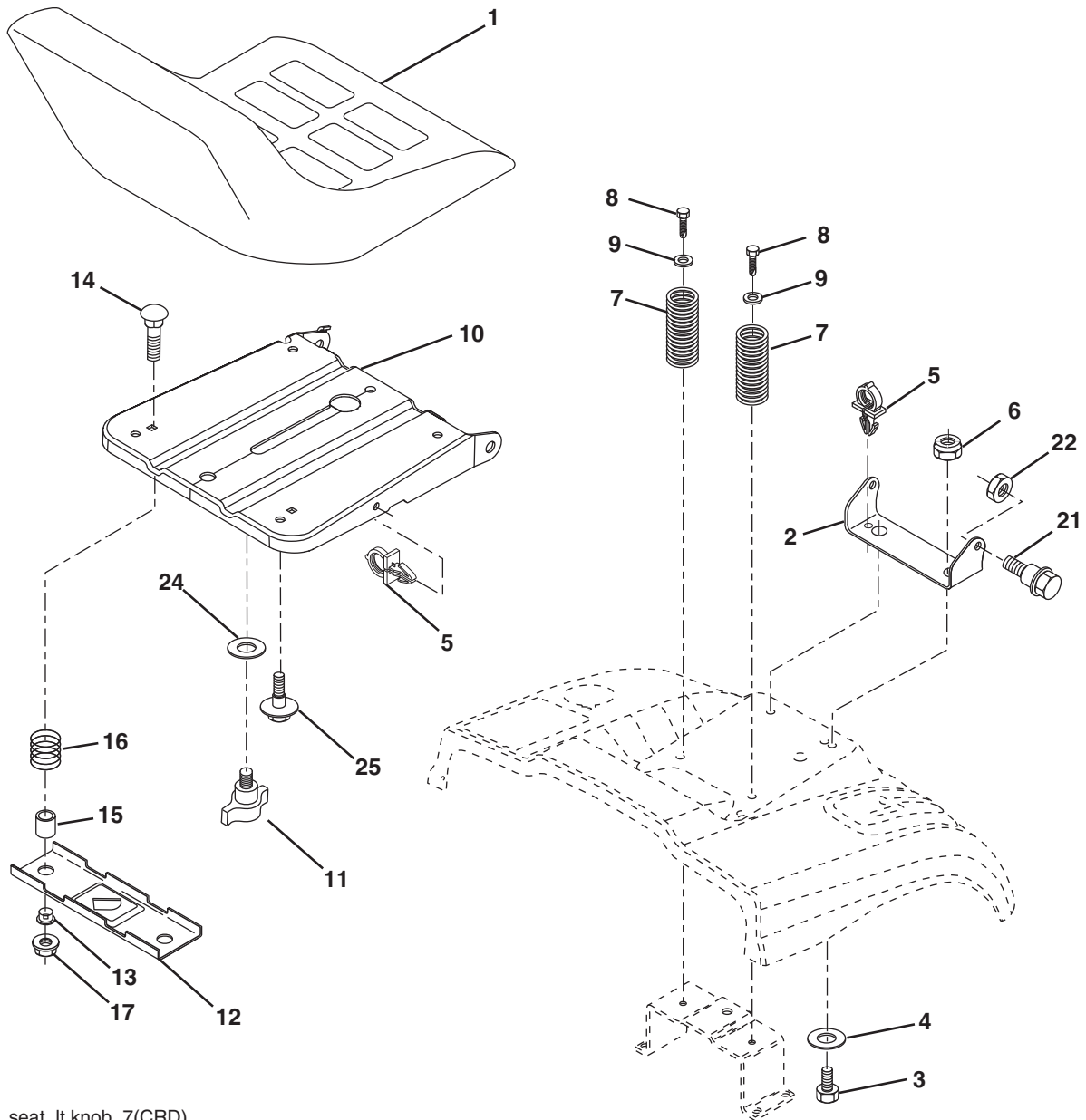

seat_lt.knob_7(CRD)

KEY NO.	PART NO.	DESCRIPTION
1	532 43 96-99	Seat
2	532 14 05-51	Bracket Pnt Pivot Seat (Blk)
3	871 11 06-16	Bolt Fin Hex 3/8-16 x 1
4	819 13 16-10	Washer Flat 13/32 x 1 x 10 Ga.
5	532 14 50-06	Clip Push In Hinged
6	873 80 06-00	Nut Lock Hx w/Ins. 3/8-16
7	532 12 41-81	Spring Seat Cprsn 2 250 Blk Zi
8	817 00 06-16	Screw 3/8-16 x 1-1/2
9	819 13 16-14	Washer 13/32 x 1 x 14 Ga.
10	532 19 55-30	Pan Pnt Seat
11	532 16 63-69	Knob Seat Adj. Wingnut
12	532 17 46-48	Bracket Pnt Mounting Switch

KEY NO.	PART NO.	DESCRIPTION
13	532 12 12-48	Bushing Snap Blk Nyl 50 Id
14	872 05 04-12	Bolt Rdhd Sht Nk 1/4-20 x 1-1/2
15	532 13 43-00	Spacer Split
16	532 12 12-50	Spring Cprsn 1.27
17	532 12 39-76	Nut Lock 1/4 Lge Flg Gr. 5 Zinc
21	532 17 18-52	Bolt Shoulder 5/16-18 unc-2A
22	873 80 05-00	Nut Hex Lock w/Ins 5/16-18
24	819 17 19-12	Washer 17/32 x 1-3/16 x 12 Ga.
25	532 12 70-18	Bolt Shoulder 5/16-18 x 62

NOTE: All component dimensions given in U.S. inches.
 1 inch = 25.4 mm

TRACTOR - MODEL NO. CTH151T (96061034301), PROD. NO. 960 61 03-43
MOWER LIFT 45

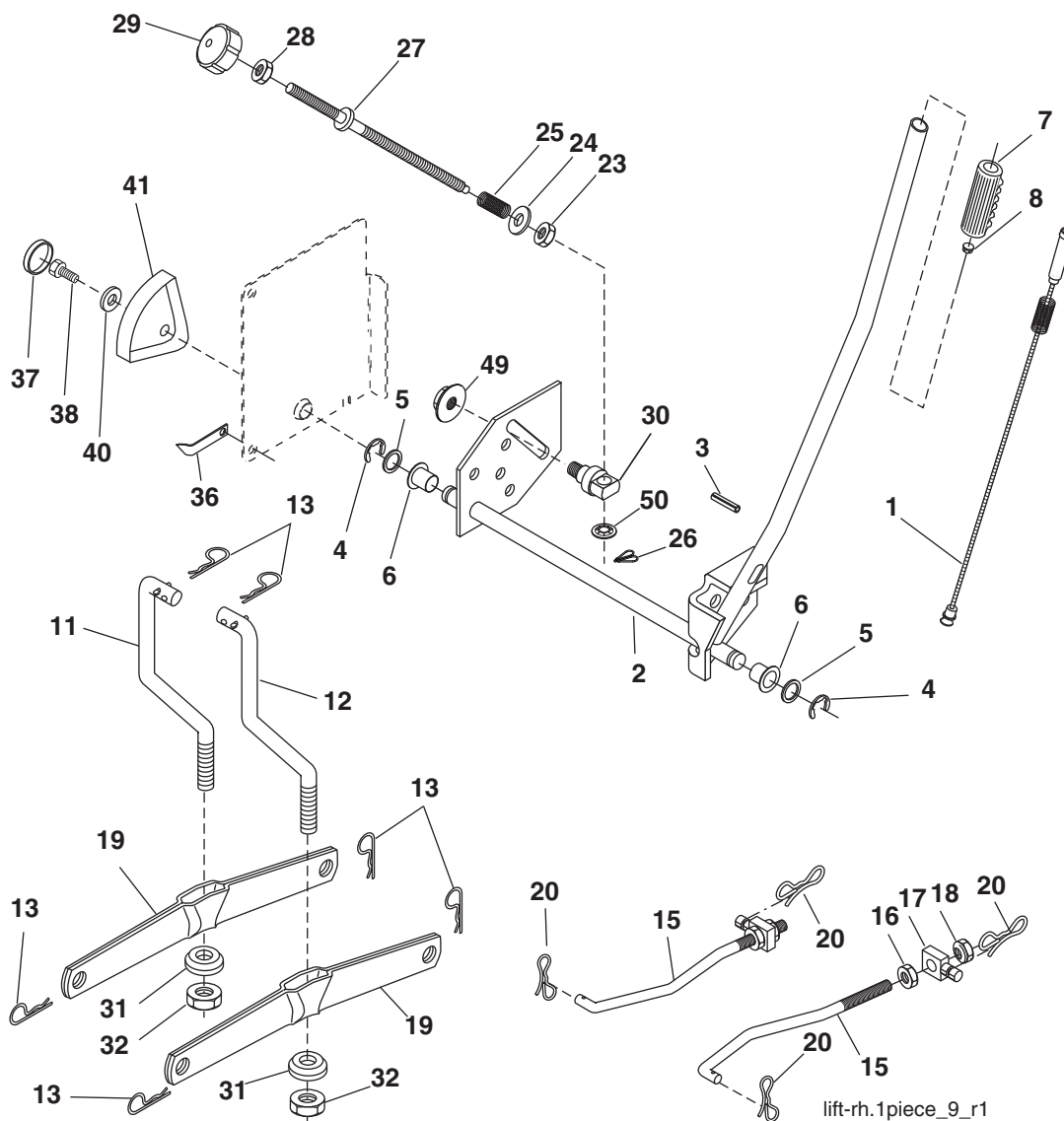

KEY NO.	PART NO.	DESCRIPTION
1	532 40 49-81	Plunger Asm. Lift Lever
2	532 15 94-71	Shaft Asm. Lift
3	532 10 57-67	Pin Groove
4	812 00 00-02	E Ring #5133-62
5	819 21 16-21	Washer 21/32 x 1 x 21 Ga.
6	532 12 01-83	Bearing Nylon
7	532 12 56-31	Grip Handle
8	532 12 45-26	Button Plunger Black
11	532 16 58-29	Link Lift LH
12	532 16 58-31	Link Lift RH
13	532 12 46-70	Retainer Spring
15	532 17 32-88	Link Front
16	873 35 08-00	Nut Jam Hex 1/2-13 unc
17	532 17 56-89	Trunnion
18	873 80 08-00	Nut Lock w/Wsh 1/2-13 unc
19	532 13 98-68	Arm Suspension Mower
20	532 19 42-09	Pin Cotter 7/16 Bow Tie Lock
23	532 11 08-07	Nut Special
24	819 13 10-16	Washer 13/32 x 5/8 x 16 Ga.

KEY NO.	PART NO.	DESCRIPTION
25	532 12 48-74	Spring 2-1/8
26	532 16 94-84	Retainer Clip
27	532 12 69-71	Rod Adj Lift Zinc
28	873 35 06-00	Nut Hex Jam 3/8-16 unc
29	532 13 80-57	Knob Inf 3/8-16 unc
30	532 15 02-33	Trunnion Infin Height
31	532 16 98-65	Bearing, Pvt. Lift.
32	873 54 06-00	Nut Crownlock 3/8-24
36	532 15 50-97	Pointer Height Indicator
37	532 12 39-35	Plug Hole Blk
38	817 06 05-16	Screw 5/16-18 x 1
40	819 11 24-10	Washer 11/32 x 1-1/2 x 10 Ga.
41	532 12 39-34	Scale Ind Height Blk
49	532 40 91-49	Nut Hex Flange
50	532 11 04-52	Nut Push Phos & Oil

NOTE: All component dimensions given in U.S. inches.
 1 inch = 25.4 mm

TRACTOR - MODEL NO. CTH151T (96061034301), PROD. NO. 960 61 03-43
 BAGGER **46**

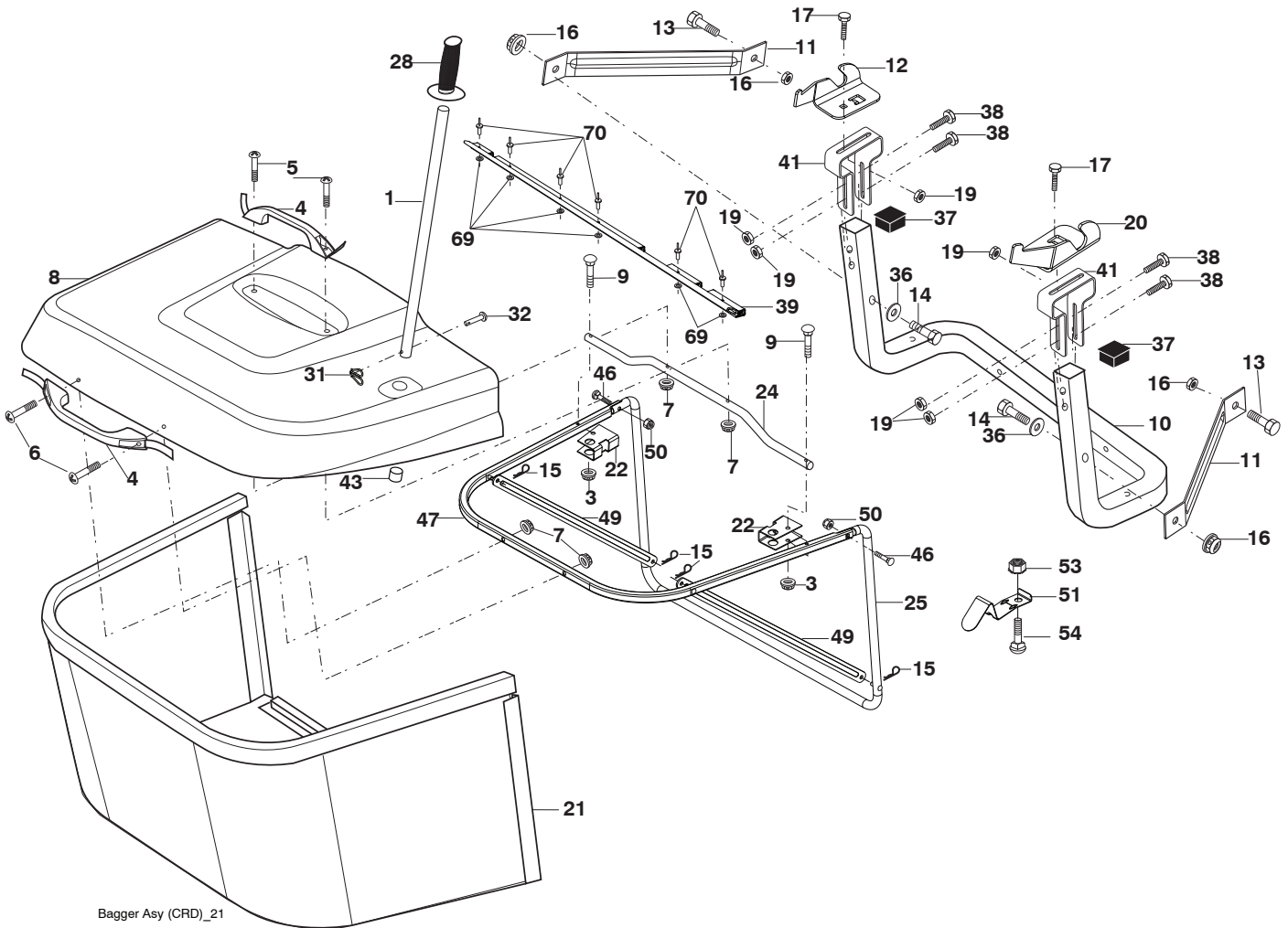

Bagger Asy (CRD)_21

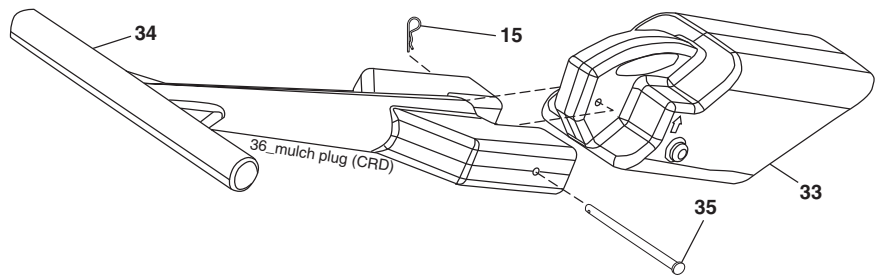

**TRACTOR - MODEL NO. CTH151T (96061034301), PROD. NO. 960 61 03-43
BAGGER 46**

KEY NO.	PART NO.	DESCRIPTION	KEY NO.	PART NO.	DESCRIPTION
1	532 42 86-10	Tube Handle Bagger CRD	31	532 16 94-84	Retainer Clip
3	532 12 39-76	Nut Lock 1/4 Lge Flg Gr. 5 Zinc	32	532 12 68-75	Rivet Rd Hd Drilled 3/8 Dia
4	532 16 99-16	Handle Bagger w/Lvrs Blk CRD	33	532 42 86-83	Plug Mulching
5	874 98 10-24	Screw Pan Head #10-24 x 1.50 Blk	34	532 16 55-70	Handle Mulcher
6	874 98 10-32	Screw Pan Hd	35	532 16 55-72	Pin Mulcher
7	873 40 10-00	Nut Wiz Lock Hex Serr/Hd 10-24	36	819 13 20-12	Washer 13/32 x 1-1/4 x 12 Ga.
8	532 44 15-43	Cover Bagger CRD	37	532 44 48-48	Plug Support Bagger CRD
9	872 14 04-18	Bolt Carriage 1/4-20 x 2.25d x Gr. 5	38	872 01 05-20	Bolt 5/16-18 x 2-1/2
10	532 18 12-82	Tube Support Bagger CRD	39	532 41 62-57	Seal Bagger
11	532 16 57-19	Bracket Support Upper Bag CRD	41	532 43 27-55	Bracket Bagger CRD
12	532 18 88-48	Bracket Pivotn LH	43	532 17 40-83	Plug Tubing
13	874 76 06-12	Bolt Fin Hex 3/8-16 unc x 3/4	46	872 11 05-10	Bolt Carr. 5/16-18 x 1-1/4 Gr.5
14	874 52 06-36	Bolt Carr.	47	532 19 37-04	Tube Upper Bagger
15	532 12 46-70	Retainer Spring	49	532 19 33-05	Bar Spreader
16	873 90 06-00	Nut Lock Flg. 3/8-16 unc	50	873 80 05-00	Nut Lock Hex w/Ins. 5/16-18 unc
17	872 14 05-06	Bolt Rdhd Sht Sqnk 5/16 -18 unc x 3/4	51	532 19 99-03	Latch Spring Bagger
19	873 90 05-00	Nut Lock Hexflange 5/16-18	53	873 51 04-00	Nut Keps Hex 1/4-20 unc
20	532 18 88-47	Bracket Pivot RH	54	872 14 04-06	Bolt RDHD 1/4-20 x 3/4
21	532 40 61-80	Bag Asm CRD	69	532 43 56-11	Washer
22	532 42 82-36	Bracket Side Bagger CRD	70	532 43 56-03	Rivet Pop
24	532 16 57-83	Tube Pivot Bagger CRD			
25	532 19 37-05	Tube Front Bagger CRD			
28	532 16 57-87	Grip Handle Black			

NOTE: All component dimensions given in U.S. inches
1 inch = 25.4 mm

