

ILLUSTRATED PARTS LIST

MODEL NO. 96041005406

CUSTOMER CATALOG NO. YTH2042TD

PRODUCT NO. 960 41 00-54

**TRACTOR - MODEL NO. YTH2042TD (96041005406), PRODUCT NO. 960 41 00-54
DECALS 27**

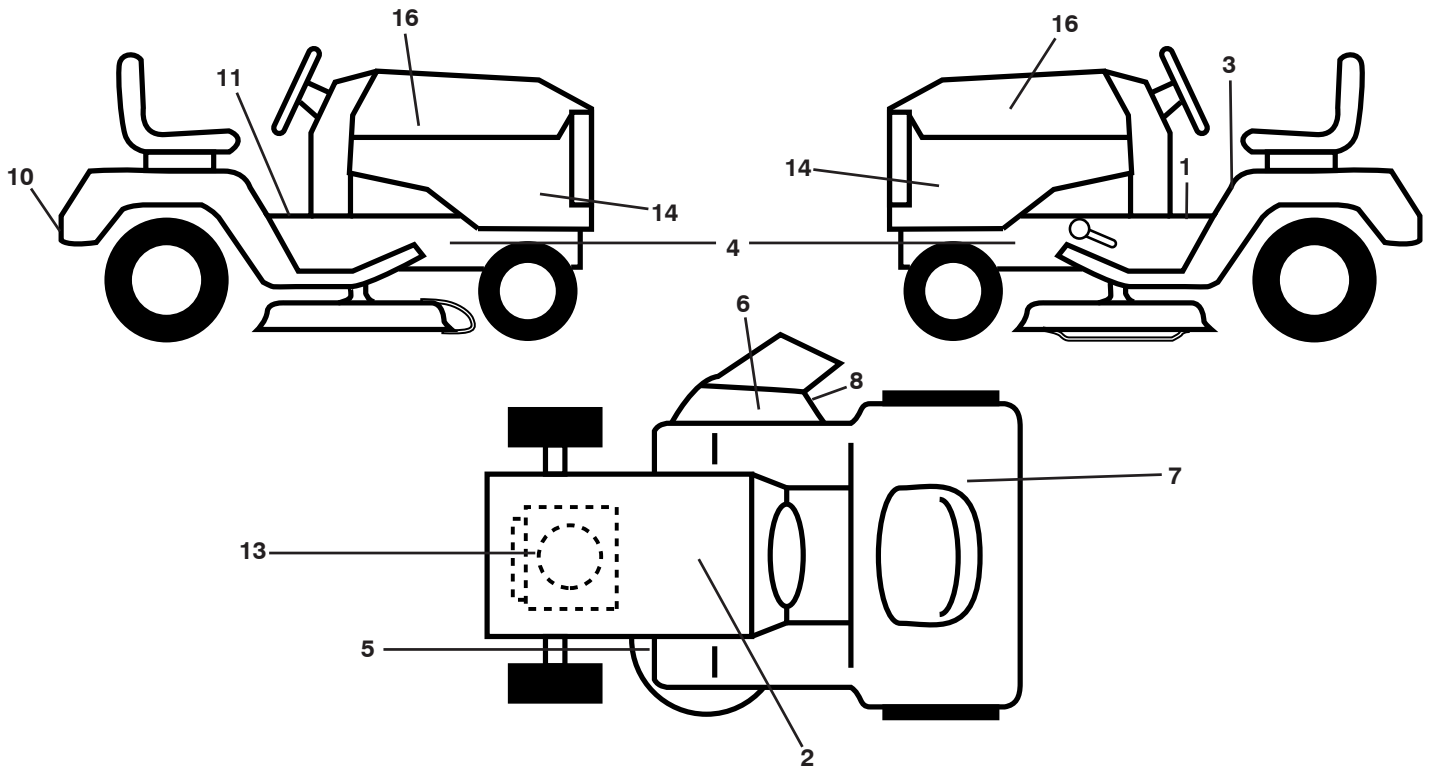

**KEY PART
NO. NO.**

KEY PART NO.	NO.	DESCRIPTION
1	581 57 80-01	Decal, Saddle
2	532 14 50-05	Decal, Battery
3	581 57 81-01	Decal, Warn. Sym.
4	581 57 96-01	Decal, Chassis Hot
5	581 58 00-01	Decal, Caution
6	584 90 46-01	Decal, Deck/Deflect. Warning
7	586 75 82-01	Decal, Consumption Mexico
8	581 57 92-01	Decal, Deflect
10	581 72 46-01	Decal, Drawbar

**KEY PART
NO. NO.**

KEY PART NO.	NO.	DESCRIPTION
11	581 72 40-01	Decal, Brake/Clutch
13	581 57 97-01	Decal, Engine
14	584 61 42-01	Decal, Panel Side
16	581 62 73-01	Decal, Hood Logo
--	581 72 48-01	Decal, Bypass
--	532 43 98-82	Pad, Footrest, LH
--	532 43 98-81	Pad, Footrest, RH
--	584 61 36-26	Manual, Operator's (English/Spanish)
--	584 82 62-69	Manual, Operator's (Portuguese)

WHEELS AND TIRES

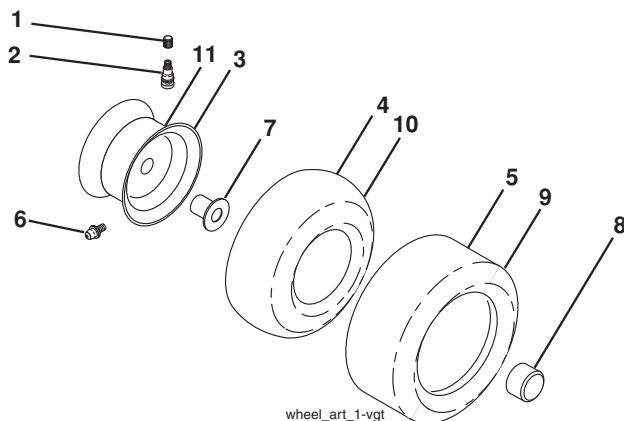

**KEY PART
NO. NO.**

KEY PART NO.	NO.	DESCRIPTION
1	532 05 91-92	Cap, Valve, Tire
2	532 06 51-39	Stem, Valve
3	532 13 83-36	Rim Assembly, Front
4	532 05 99-04	Tube, Front (Service Item Only)
5	532 10 62-22	Tire, Front 15 x 6-6
6	532 12 49-57	Fitting, Grease (Front Wheel Only)
7	532 12 49-59	Bearing, Flange (Front Wheel Only)
8	532 17 50-39	Cap, Axle (Front Wheel Only)
9	532 12 20-82	Tire, Rear 20 x 10-8
10	532 00 71-52	Tube, Rear (Service Item Only)
11	532 13 83-37	Rim Assembly, Rear
--	532 14 43-34	Sealant, Tire (10 oz. Tube)

NOTE: All component dimensions given in U.S. inches:
1 inch = 25.4 mm.

TRACTOR - MODEL NO. YTH2042TD (96041005406), PRODUCT NO. 960 41 00-54

SCHEMATIC 38

SCH12

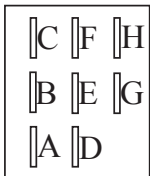
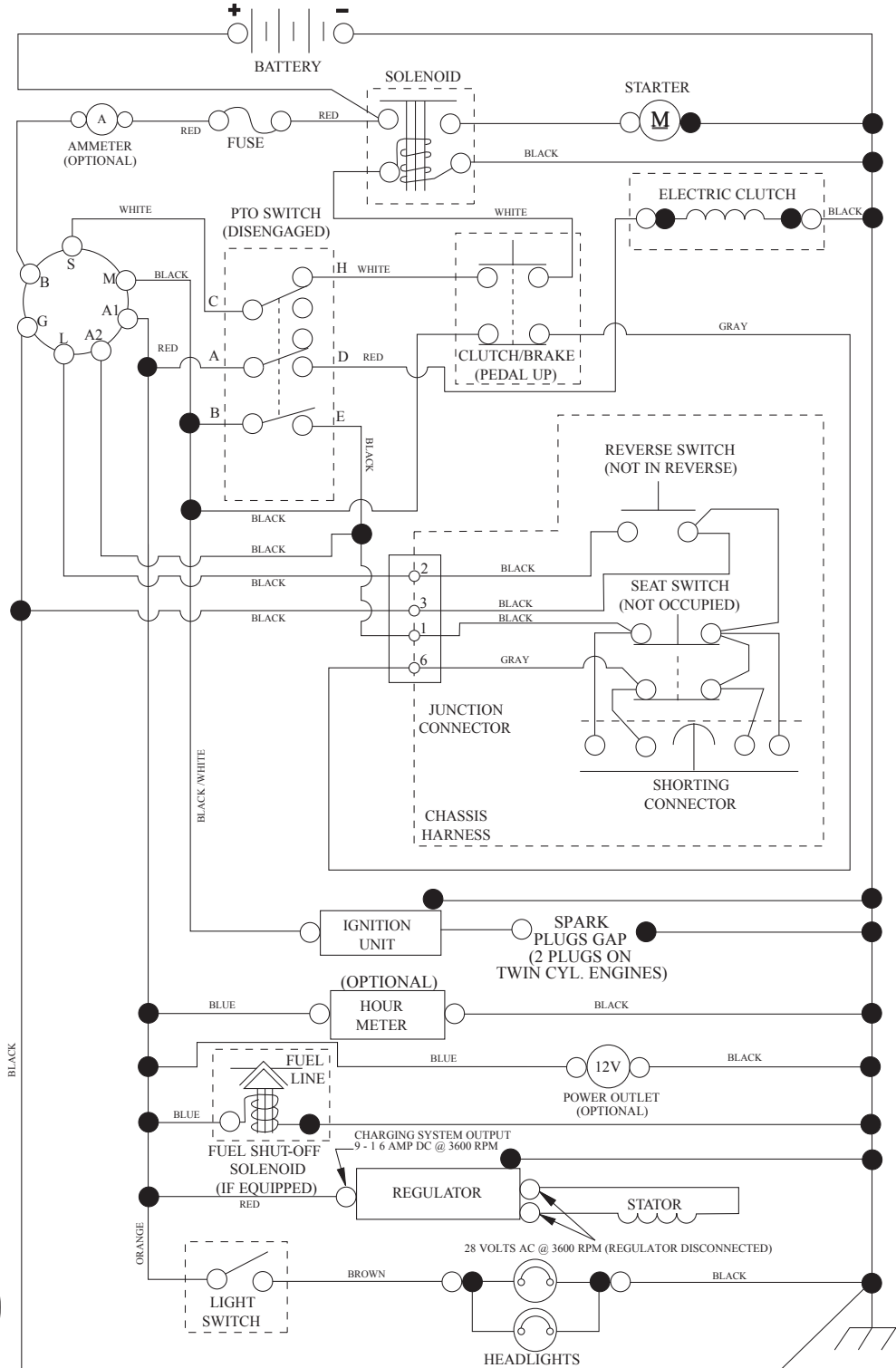

PTO SWITCH (MATING SIDE)

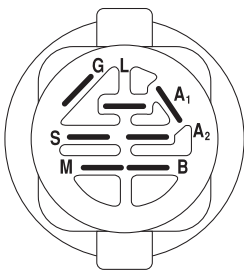

IGNITION SWITCH

POSITION	CIRCUIT	"MAKE"
OFF	M+G+A1	
RUN/OVERRIDE	B+A1	
RUN	B+A1	L+A2
START	B + S + A1	

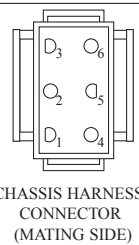

CHASSIS HARNESS CONNECTOR (MATING SIDE)

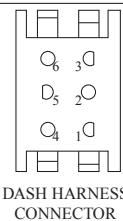

DASH HARNESS CONNECTOR

WIRING INSULATED CLIPS
NOTE: IF WIRING INSULATED CLIPS WERE REMOVED FOR SERVICING OF UNIT, THEY SHOULD BE RE-INSTALLED TO PROPERLY SECURE YOUR WIRING.

●
NON-REMOVABLE CONNECTIONS

○
REMOVABLE CONNECTIONS

TRACTOR - MODEL NO. YTH2042TD (96041005406), PRODUCT NO. 960 41 00-54
ELECTRICAL 32

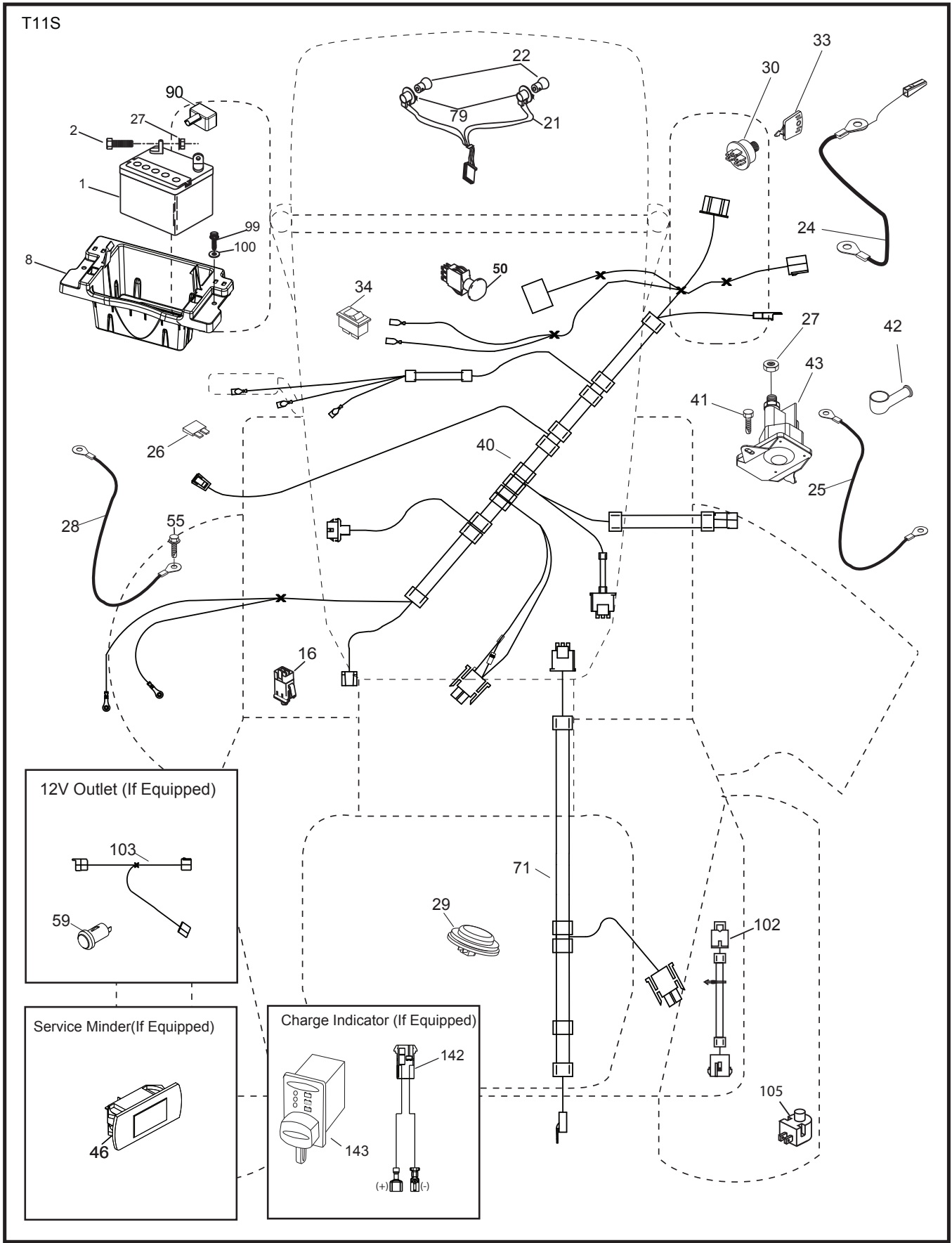

**TRACTOR - MODEL NO. YTH2042TD (96041005406), PRODUCT NO. 960 41 00-54
ELECTRICAL 32**

KEY NO.	PART NO.	DESCRIPTION
1	532 16 34-65	Battery
2	874 76 04-12	Bolt Hex Hd 1/4-20 unc x 3/4
8	587 20 51-01	Battery Box
16	532 17 61-38	Switch Interlock
21	532 40 02-52	Harness Socket Light
22	532 00 41-52	Bulb, Light #1156
24	585 55 56-01	Cable Battery
25	585 55 55-01	Cable Starter
26	532 17 51-58	Fuse
27	873 51 04-00	Nut Keps Hex 1/4-20 unc
28	532 14 54-91	Cable Ground 21" Blk 6 Ga.
29	532 40 15-45	Switch Seat
30	532 19 33-50	Switch Ign
33	532 41 19-33	Key/Chain
34	532 11 07-12	Switch Light/Reset
40	501 13 29-01	Harness Ignition Dash
41	817 72 04-08	Screw Thd Cut 1/4-20 x 1/2
42	532 13 15-63	Cover Terminal Red
43	532 19 25-07	Solenoid
46	586 16 18-01	Gauge Hourmeter
50	582 10 76-01	Switch PTO
55	817 06 05-12	Screw Thdrol 5/16-18 x 3/4
59	532 40 03-03	Outlet 12 Volt
71	532 19 42-76	Harness Chassis
79	532 17 52-42	Socket Asm. Bulb
90	532 43 53-95	Cover Terminal Battery
99	817 67 04-12	Screw Hexwsh Thdrol 1/4-20 x 3/4
100	819 09 14-16	Washer 9/32 x 7/8 x 16 Ga.
102	532 40 44-54	Harness Pigtail
103	532 40 79-62	Harness Pigtail 12v Outlet
105	532 40 75-68	Switch Reverse

NOTE: All component dimensions given in U.S. inches:
1 inch = 25.4 mm.

TRACTOR - MODEL NO. YTH2042TD (96041005406), PRODUCT NO. 960 41 00-54
CHASSIS AND ENCLOSURES **39**

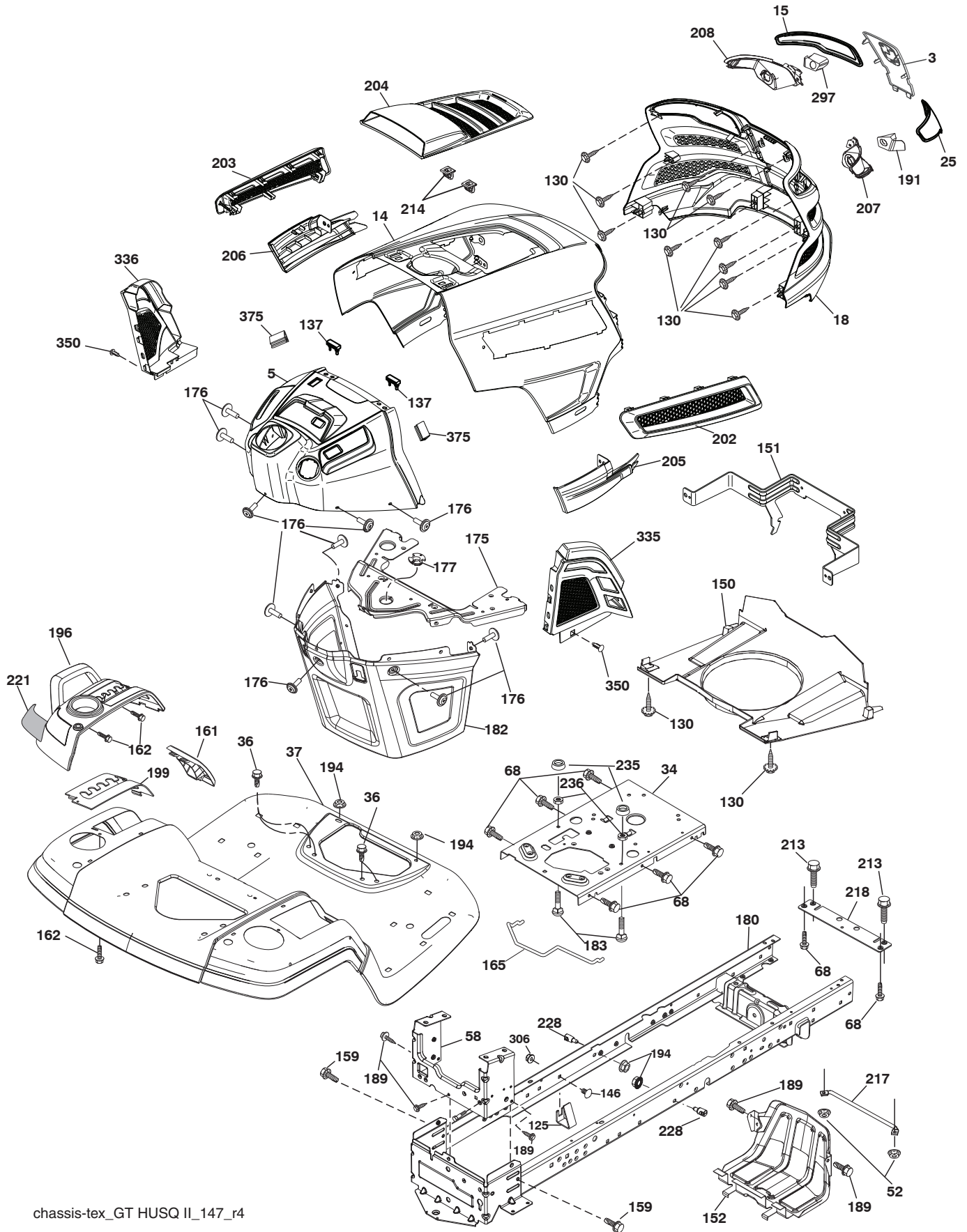

chassis-tex_GT HUSQ II_147_r4

**TRACTOR - MODEL NO. YTH2042TD (96041005406), PRODUCT NO. 960 41 00-54
CHASSIS AND ENCLOSURES 39**

KEY PART NO. NO.	DESCRIPTION	KEY PART NO. NO.	DESCRIPTION		
3	532 44 44-81	Applique	191	532 43 74-55	Insert Reflective RH
5	579 77 05-01	Dash	194	873 90 05-00	Nut Lock Hex Flange 5/16-18
14	532 44 11-77	Hood	196	532 43 97-16	Console Asm. Deck Lift
15	532 43 97-33	Lens LH	199	532 19 82-59	Plate Deck Lift
18	532 44 06-53	Grille Asm.	202	532 43 97-28	Vent Side Hood RH
25	532 44 33-85	Lens RH	203	532 43 97-27	Vent Side Hood LH
34	580 91 08-01	Plate Engine	204	532 44 44-84	Vent Top Hood
36	817 06 05-12	Screw 5/16-18 x 3/4	205	532 43 97-30	Skirt Hood Side RH
37	532 44 12-08	Fender	206	532 43 97-29	Skirt Hood Side LH
52	873 68 05-00	Nut Lock 5/16-18	207	532 43 97-34	Bezel RH
58	532 41 22-81	Drawbar Upper	208	532 43 97-35	Bezel LH
68	817 49 05-08	Screw 5/16-18 x 1/2	213	874 76 05-12	Bolt 5/16-18 unc x 3/4
125	581 68 48-01	Clip Fuel Line	214	532 19 91-45	Clip Retainer Tinner
130	532 41 63-58	Screw #10 x 0.750	217	532 40 91-67	Rod Pivot
137	532 40 75-90	Bumper Dash	218	532 19 63-95	X-Piece Hood Stop
146	581 85 79-01	Bolt	221	532 19 89-09	Reflector LH
150	532 43 97-74	Air Duct	228	532 19 51-61	Stud Fastner
151	532 43 66-70	Bracket Pivot	235	532 40 61-29	Spacer Fender
152	532 43 98-70	Shield Browning	236	873 93 05-00	Nut Lock 5/16-18 unc
159	817 00 06-12	Screw 3/8-16 x 3/4	297	532 43 74-56	Insert Reflective LH
161	532 43 99-29	Window Fuel	306	873 90 06-00	Nut Lock
162	532 14 24-32	Screw	336	532 44 53-09	Cover Dash LH
165	532 19 68-26	Support Tank Rear	335	532 44 82-04	Cover Dash RH
175	532 19 63-04	Crossmember	350	532 44 51-43	Clip
176	532 40 07-76	Screw 10-24 x 5/8	375	586 90 82-01	Dash Clip-On Bumper
177	532 19 52-28	Bushing Steering	--	532 40 09-44	Kit Bumper
180	532 41 50-64	Chassis			
182	532 40 68-59	Dash Lower			
183	874 52 05-20	Bolt 5/16-18 x 1-1/4			
189	817 00 05-12	Screw 5/16-18 x 3/4			

NOTE: All component dimensions given in U.S. inches:
1 inch = 25.4 mm.

TRACTOR - MODEL NO. YTH2042TD (96041005406), PRODUCT NO. 960 41 00-54
DRIVE 40

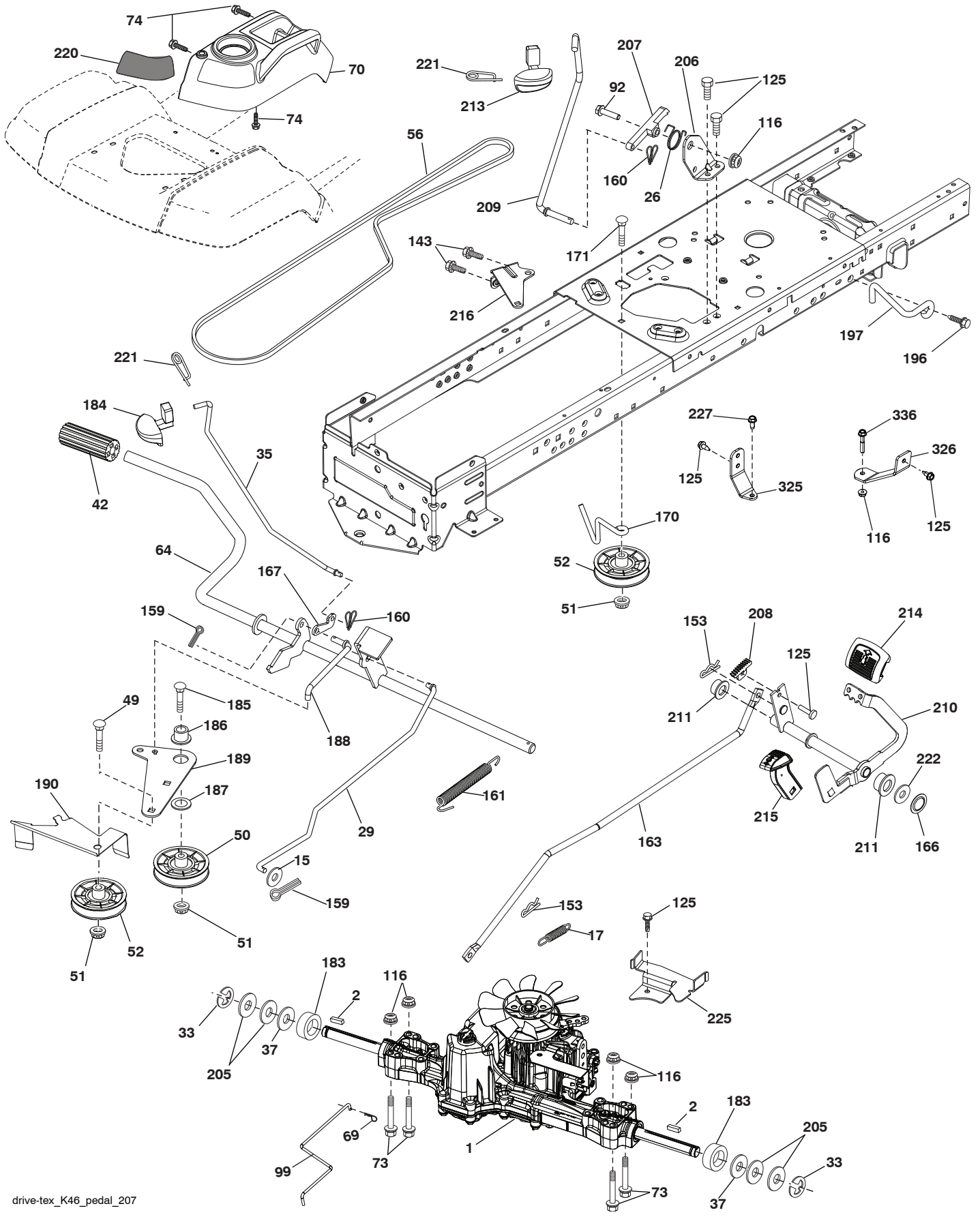

drive-tex_K46_pedal_207

**TRACTOR - MODEL NO. YTH2042TD (96041005406), PRODUCT NO. 960 41 00-54
DRIVE **40****

KEY NO.	PART NO.	DESCRIPTION	KEY NO.	PART NO.	DESCRIPTION
1	---	Transaxle, TUFFTORQ K46 CR (501051401) (Order parts from transaxle manufacturer)	183	532 13 70-57	Spacer Split
2	532 12 35-83	Key 1/4 x 2.5	184	587 65 37-01	Handle Parking Brake
15	819 13 13-16	Washer 13/32 x 13/16 x 16 Ga.	185	872 11 06-22	Bolt RDHD 3/8-16 x 2-3/4 Gr. 5
17	532 41 36-78	Spring, Brake	186	532 19 43-21	Spacer Retainer
26	532 19 96-79	Spring Return Cruise	187	819 13 32-10	Washer
29	532 40 38-06	Rod, Brake	188	532 19 43-23	Link Clutch Ground Drive
33	812 00 00-01	Ring E	189	532 19 43-17	Bellcrank Ground Drive
35	583 86 45-01	Rod, Brake, Park	190	532 19 43-18	Keeper Bellcrank Ground Drive
37	532 18 89-67	Washer Hardened	196	817 00 06-16	Screw 3/8-16 x 1
42	532 12 48-72	Cover, Foot Pedal	197	585 65 86-01	Link Clutch Anti-Rotation
49	872 11 06-14	Bolt	205	532 12 17-48	Washer
50	532 19 43-27	Pulley Idler Flat	206	532 44 85-96	Bracket Mount Latch Cruise
51	873 90 06-00	Lock Nut 3/8-16	207	587 03 14-01	Latch Control Cruise
52	532 19 43-26	Idler V-Groove	208	532 19 78-69	Gear Sector Control Cruise
56	532 13 09-69	V-Belt, Drive	209	532 19 95-92	Rod Control Cruise
64	532 19 78-65	Shaft Asm. Pedal Brake Control	210	532 19 78-60	Rocker Asm. Pedal Control
69	532 42 33-03	Hairpin Soft Zink .059 x 1.125	211	532 12 01-83	Bearing Nylon
70	532 43 96-61	Console Asm.	213	532 40 31-19	Knob Control Cruise
73	874 49 05-40	Bolt Hex 5/16-18 Gr. 5	214	532 42 12-63	Pedal Forward
74	532 14 24-32	Screw 1/4 x 1/2	215	586 60 65-02	Pedal Reverse
92	874 76 05-20	Bolt Fin Hex 5/16-18 unc x 1.25	216	532 19 61-31	Bracket Pulley Idler
99	582 40 45-01	Rod Spring Bypass	220	532 19 89-08	Reflector RH
116	873 90 05-00	Nut Lock Hex Flange 5/16-18	221	532 40 31-87	Retainer Spring Clip Handle
125	817 00 05-12	Screw 5/16-18 x 3/4	222	879 21 20-10	Washer 21/32 x 1-1/4 x 10 Ga.
143	817 49 05-08	Screw 5/16-18 x 1/2	225	532 40 33-19	Keeper Belt Trans.
153	532 12 47-88	Retainer Spring	227	817 49 05-12	Screw THDROL
159	876 02 04-12	Pin Cotter 1/8 x 3/4	325	585 66 85-02	Torque Strap K46 LT RH
160	532 16 94-84	Retainer Clip	326	585 67 08-02	Bracket TRQ STP 46 20" Tire RH
161	532 10 57-09	Spring, Return, Clutch	336	587 25 96-01	Bolt 5/16 - 18 x 1-3/4 Flanged
163	532 44 82-75	Rod Pedal Control			
166	532 42 91-64	Nut Push .625			
167	532 40 52-57	Latch Brake Parking			
170	532 19 43-22	Keeper Belt Centerspan			
171	872 11 06-16	Bolt RDHD SQNK 3/8-16 unc x 2			

NOTE: All component dimensions given in U.S. inches:
1 inch = 25.4 mm.

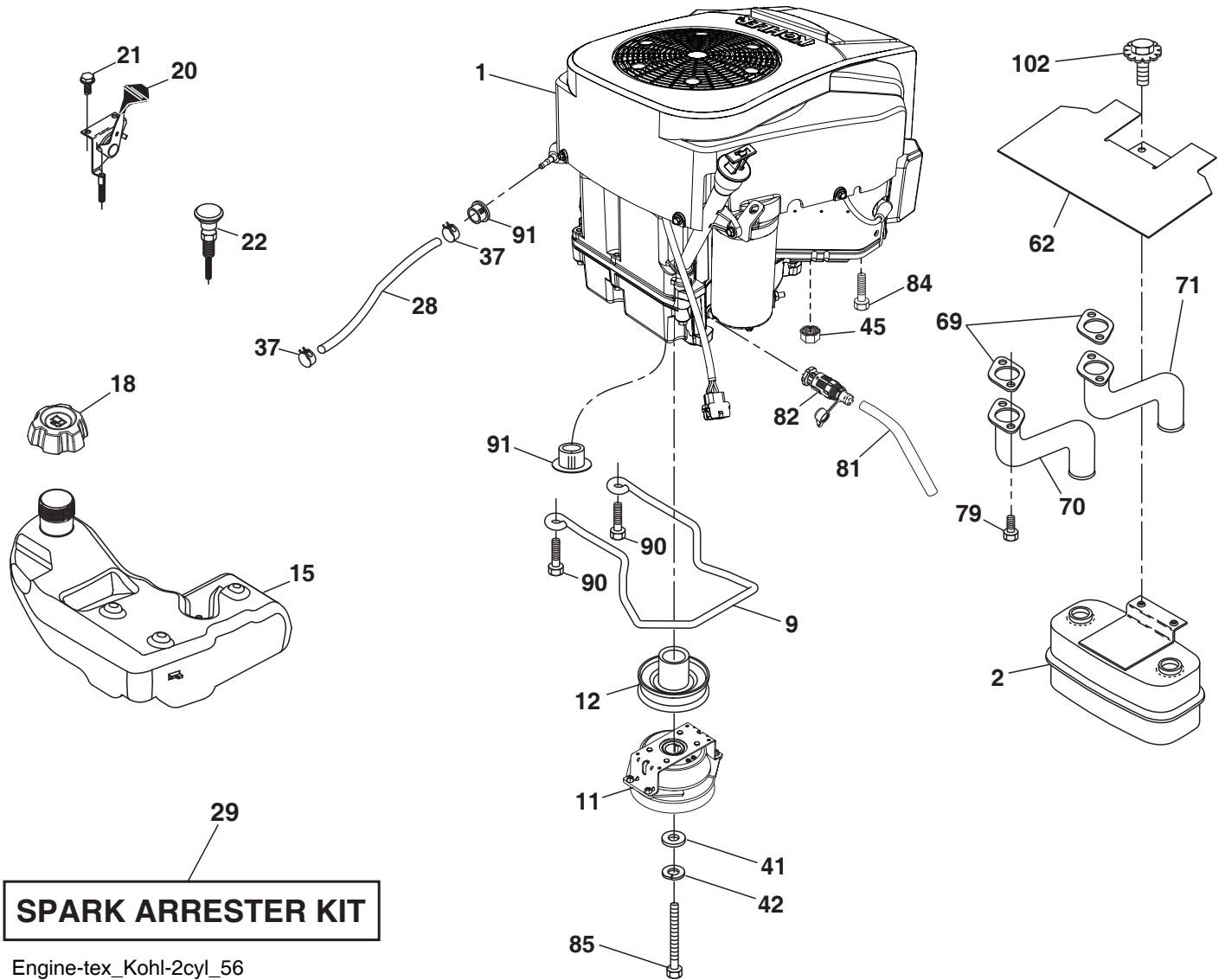

**TRACTOR - MODEL NO. YTH2042TD (96041005406), PRODUCT NO. 960 41 00-54
ENGINE 24**

KEY NO.	PART NO.	DESCRIPTION
1	-----	Engine Kohl Model No. KT715-3016 (585445801) (Order parts from engine manufacturer.)
2	532 44 59-62	Muffler
9	501 83 26-01	Keeper Belt Engine
11	587 24 15-01	Clutch Electric
12	532 40 50-97	Pulley Engine
15	532 19 34-99	Tank Fuel 4.0
18	584 24 87-02	Cap Asm
20	532 18 29-37	Control Throttle
21	532 41 63-58	Screw #10 x 0.750
22	532 19 15-96	Control Choke
28	532 40 11-35	Fuel Line
29	532 13 71-80	Spark Arrester Kit
37	532 12 34-87	Clamp Hose
41	532 12 61-97	Washer 1-1/2 OD x 15/32 ID x .250
42	810 04 07-00	Washer Lock 7/16
45	873 51 04-00	Nut Keps Hex 1/4-20 unc
62	532 43 40-17	Shield Heat Muffler
69	532 18 60-54	Gasket
70	583 95 45-01	Tube Exhaust LH
71	583 95 48-01	Tube Exhaust RH
79	532 19 23-34	Screw Socket HD 5/16-18 x .75
81	532 14 84-56	Tube Drain Oil Easy
82	532 42 82-87	Valve Oil Drain
84	817 12 06-16	Screw 3/8-16 x 1
85	581 33 28-04	Bolt 7/16-20 x 3.5 Gr. 5
90	817 00 06-16	Screw 3/8-16 x 1
91	532 18 74-95	Bushing
102	817 00 05-12	Screw 5/16-18 x 3/4

NOTE: All component dimensions given in U.S. inches:
1 inch = 25.4 mm.

TRACTOR - MODEL NO. YTH2042TD (96041005406), PRODUCT NO. 960 41 00-54
STEERING ASSEMBLY **41**

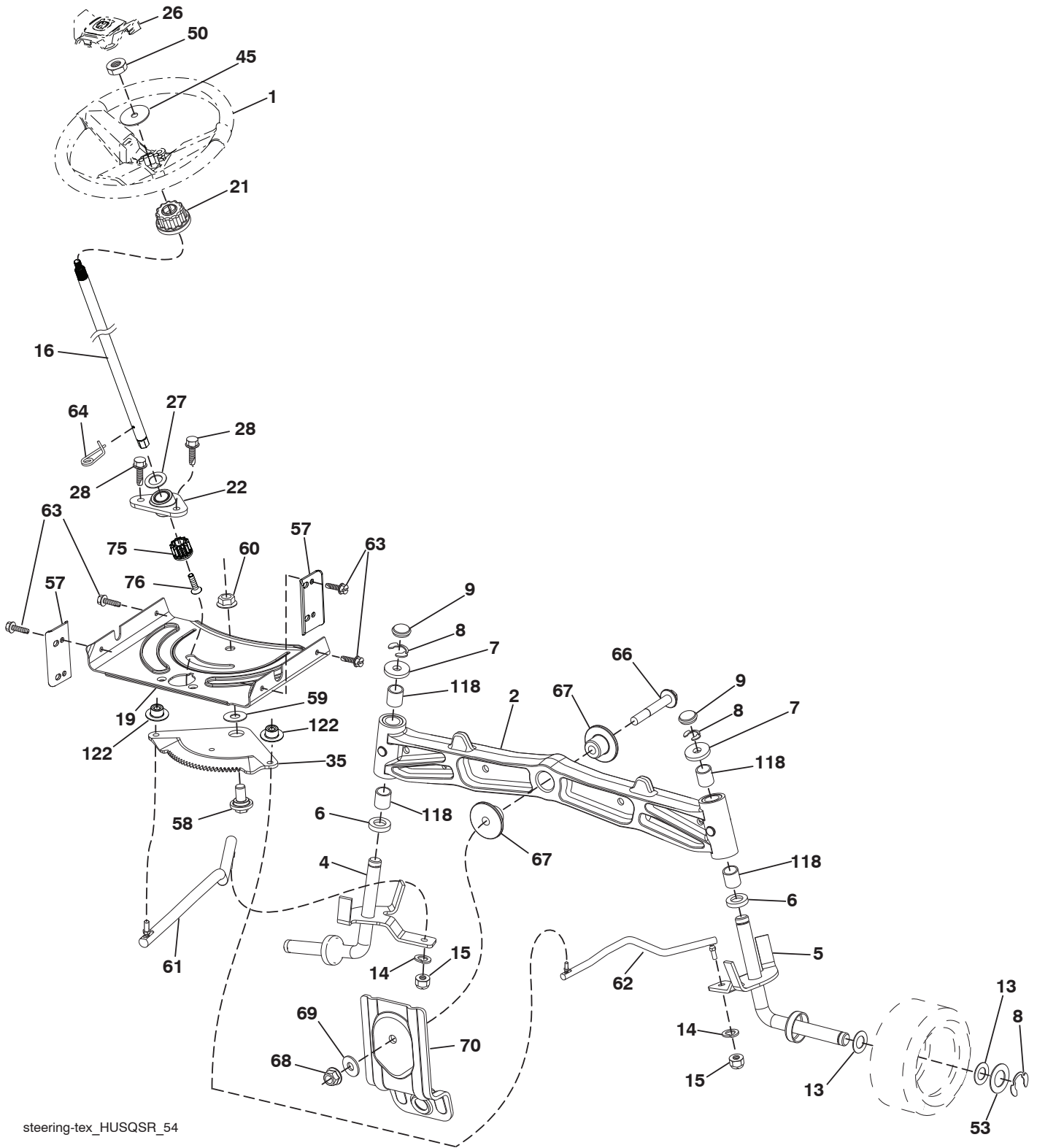

steering-tex_HUSQSR_54

**TRACTOR - MODEL NO. YTH2042TD (96041005406), PRODUCT NO. 960 41 00-54
STEERING ASSEMBLY **41****

KEY NO.	PART NO.	DESCRIPTION
1	532 43 97-40	Wheel, Steering
2	532 41 35-91	Axle Asm., Front
4	532 40 30-87	Spindle Asm., LH
5	532 40 30-88	Spindle Asm., RH
6	532 12 49-31	Bearing, Race Thrust Harden
7	532 12 17-48	Washer 25/32 x 1-5/8 x 16 Ga.
8	812 00 00-29	Ring, Klip #T5304-75
9	532 12 12-32	Cap, Spindle
13	532 12 17-49	Washer 25/32 x 1-1/4 x 16 Ga.
14	810 04 06-00	Washer, Lock Hvy Hlcl Spr 3/8
15	873 54 06-00	Nut, Crown Lock 3/8-24 unf
16	587 01 60-02	Steering Shaft
19	532 19 47-29	Plate Steering
21	586 84 02-01	Adapter Wheel Steering
22	585 02 98-02	Bearing
26	532 43 97-43	Insert, Wheel Steering
27	819 21 16-16	Washer
28	817 00 06-12	Screw 3/8-16 x 3/4
35	532 19 47-32	Gear, Sector Plate
45	587 01 64-01	Washer 3/8 ID 2-3/8 OD 12 Ga. PLTD
50	873 90 06-00	Nut Lock Flg 3/8-16 unc
53	532 18 89-67	Washer Hardened .793 x 1.637 x .060
57	532 40 74-65	Bracket Upstop
58	532 19 47-47	Bolt Shoulder Sector Pivot CFM
59	532 19 47-48	Washer Thrust Sector Steering
60	873 97 10-00	Nut Flange Lock 5/8-11
61	532 19 47-40	Draglink, LH
62	532 19 47-41	Draglink, RH
63	817 00 05-12	Screw 5/16-18 x 3/4
64	532 19 98-49	Retainer Clip Spring Steering
66	871 02 07-48	Bolt Hex Fghd 7/16-14 x 3 Serr
67	532 19 47-37	Bushing PM Front Axle
68	873 90 07-00	Nut Lock Flange 7/16-14 Gr. 5
69	532 19 91-62	Washer 1.5 x .505 x .118
70	585 33 88-01	Bracket Deck Susp. Front
75	580 68 37-01	Pinion
76	580 68 36-01	Screw Head Sock
118	532 40 60-13	Bushing
122	532 44 49-62	Cap Gear

NOTE: All component dimensions given in U.S. inches:
1 inch = 25.4 mm.

TRACTOR - MODEL NO. YTH2042TD (96041005406), PRODUCT NO. 960 41 00-54
MOWER DECK 44

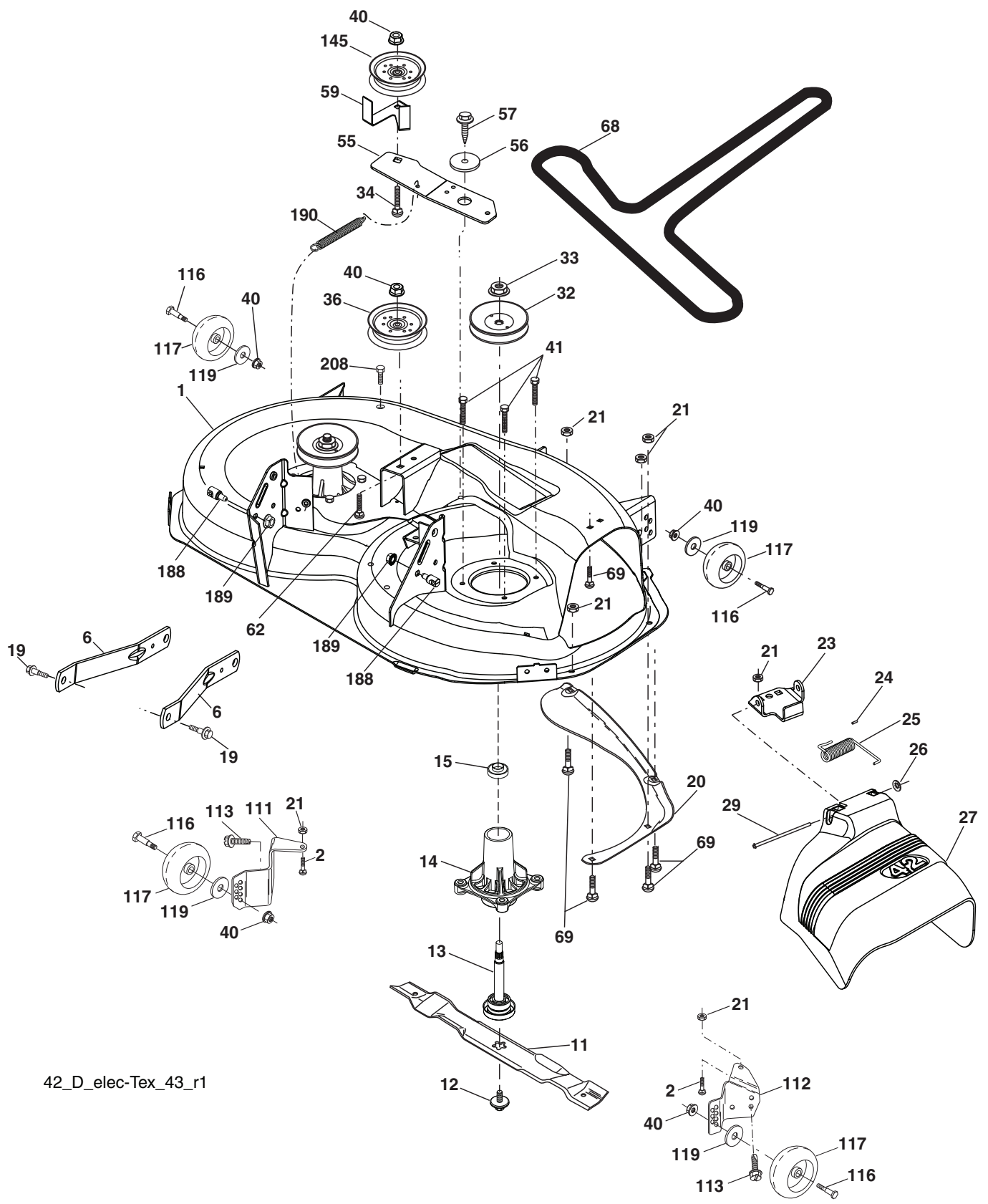

42_D_elec-Tex_43_r1

**TRACTOR - MODEL NO. YTH2042TD (96041005406), PRODUCT NO. 960 41 00-54
MOWER DECK 44**

KEY PART NO. NO.	DESCRIPTION	KEY PART NO. NO.	DESCRIPTION
1 532 43 98-17	Mower Housing	62 872 11 06-16	Bolt RDHD SQNK 3/8-16 x 2
2 872 14 05-06	Bolt RDHD SQNK 5/16-18 unc x 3/4	68 532 14 49-59	V-Belt
6 532 19 51-86	Arm Suspension	69 872 14 05-05	Bolt
11 532 13 89-71	Blade, 42" Hi-Lift (For bagging or discharge)	111 532 40 47-84	Bracket Wheel Gauge LH 42"
12 584 30 93-01	Screw	112 532 40 47-85	Bracket Wheel Gauge RH 42"
13 587 25 65-01	Shaft Assembly, Mandrel	113 817 00 05-10	Bolt 5/16-18 Hex WHS HD LCKSERR
14 532 18 72-81	Housing, Mandrel	116 532 12 48-42	Bolt, Shoulder
15 585 32 39-01	Bearing, Mandrel	117 532 18 86-06	Wheel, Gauge
19 532 19 65-39	Bolt, Shoulder	119 819 12 14-14	Washer 3/8 x 7/8 x 14 Ga.
20 532 15 97-70	Baffle, Vortex	145 532 19 31-97	Pulley Idler
21 873 68 05-00	Nut, Crownlock 5/16-18 unc	188 532 19 51-61	Stud Fastener
23 532 19 25-57	Bracket, Deflector	189 873 90 05-00	Nut Lock Hex Flange
24 532 10 53-04	Cap, Sleeve	190 532 19 72-51	Spring Mower Drive
25 532 19 70-26	Spring, Torsion, Deflector	208 817 67 06-08	Screw THDROL 3/8-16 x 1/2
26 532 11 04-52	Nut, Push	-- 587 25 33-01	Mandrel Assembly (Includes housing (Key #14), shaft assem- bly (Key #13), and bearing only (Key #15) - pulley/nut/washer and blade bolt/washers not included.)
27 532 40 30-04	Shield, Deflector		
29 532 13 14-91	Rod, Hinge		
32 532 15 35-35	Pulley, Mandrel		
33 532 40 02-34	Nut, Toplock, Flanged		
34 872 11 06-12	Bolt Carr Sh. 3/8-16 x 1-1/2 Gr. 5	-- 532 40 12-28	Replacement Mower, Complete
36 532 19 73-79	Pulley, Idler, Primary		
40 873 90 06-00	Nut, Lock Flg. 3/8-16 unc		
41 584 95 39-01	Bolt Hx Wshr Hd 3/16-18 x 1.19		
55 532 43 71-10	Arm, Idler		
56 532 19 90-92	Spacer, Retainer		
57 817 00 06-16	Screw 3/8-16 x 1		
59 532 14 10-43	Guard, Tuv Idler		

NOTE: All component dimensions given in U.S. inches:
1 inch = 25.4 mm.

TRACTOR - MODEL NO. YTH2042TD (96041005406), PRODUCT NO. 960 41 00-54
MOWER LIFT 45

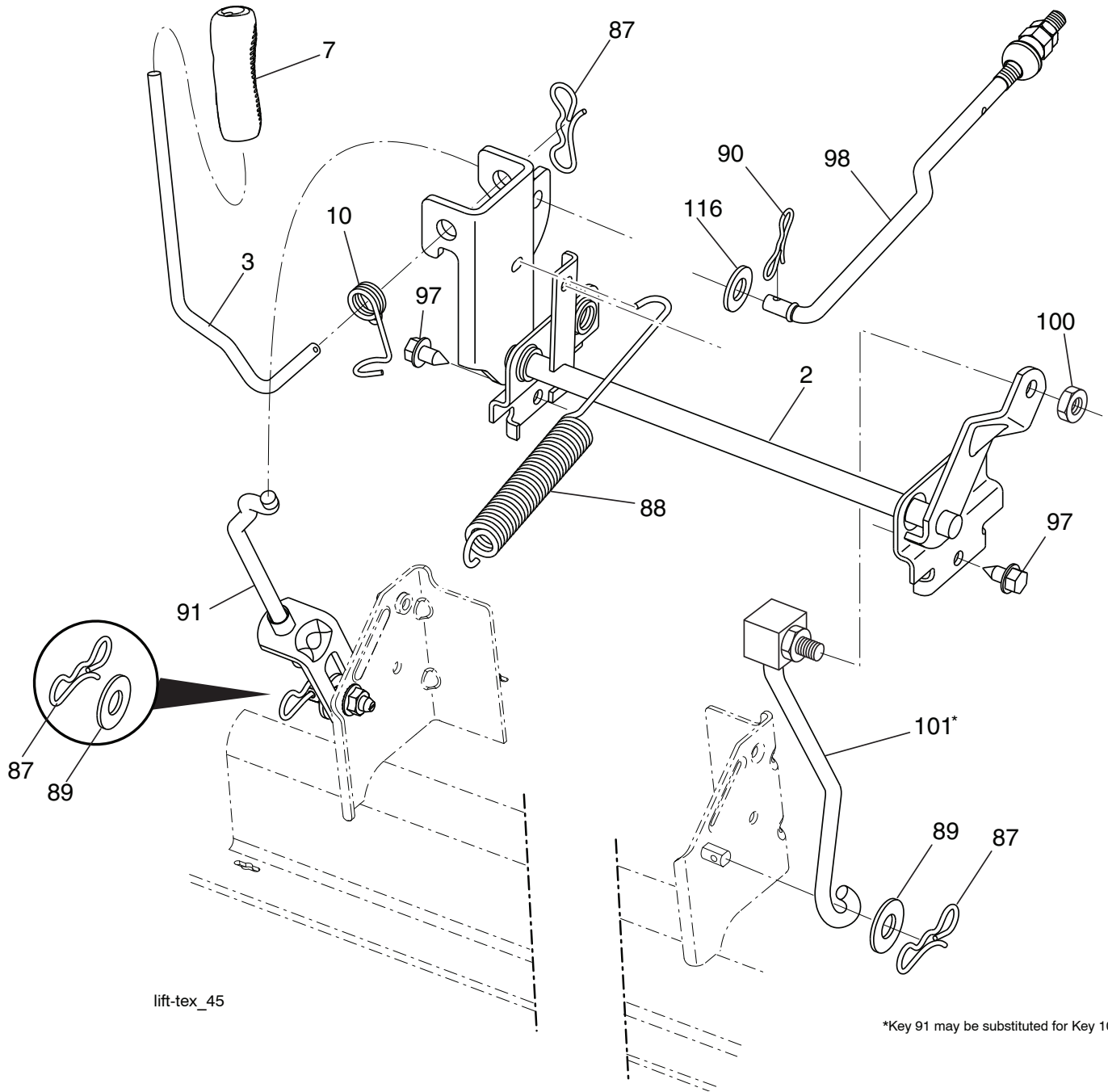

lift-tex_45

*Key 91 may be substituted for Key 101

KEY NO.	PART NO.	DESCRIPTION
2	532 42 20-27	Shaft Asm., Lift
3	532 19 52-30	Lever Asm., Lift
7	580 96 23-01	Grip, Lever
10	532 19 63-14	Spring Torsion
87	532 19 42-09	Pin Cotter 7/16 Bow Tie Lock
88	532 41 07-10	Spring Lift Assist
89	819 19 19-12	Washer Clear Zinc
90	532 19 42-08	Pin Cotter 5/16 Bow Tie Lock
91	532 19 51-81	Link Lift Susp Mower Rear

KEY NO.	PART NO.	DESCRIPTION
97	817 00 06-12	Screw 3/8-16 x 3/4
98	532 19 52-70	Link Lift Susp. Front Mower
100	873 93 06-00	Nut Centerlock 3/8-16 unc
101	532 40 70-03	Link Asm. Lift FXD
116	819 15 15-16	Washer 15/32 x 15/16 x 16 Ga.

NOTE: All component dimensions given in U.S. inches:
 1 inch = 25.4 mm.

**TRACTOR - MODEL NO. YTH2042TD (96041005406), PRODUCT NO. 960 41 00-54
SEAT ASSEMBLY 42**

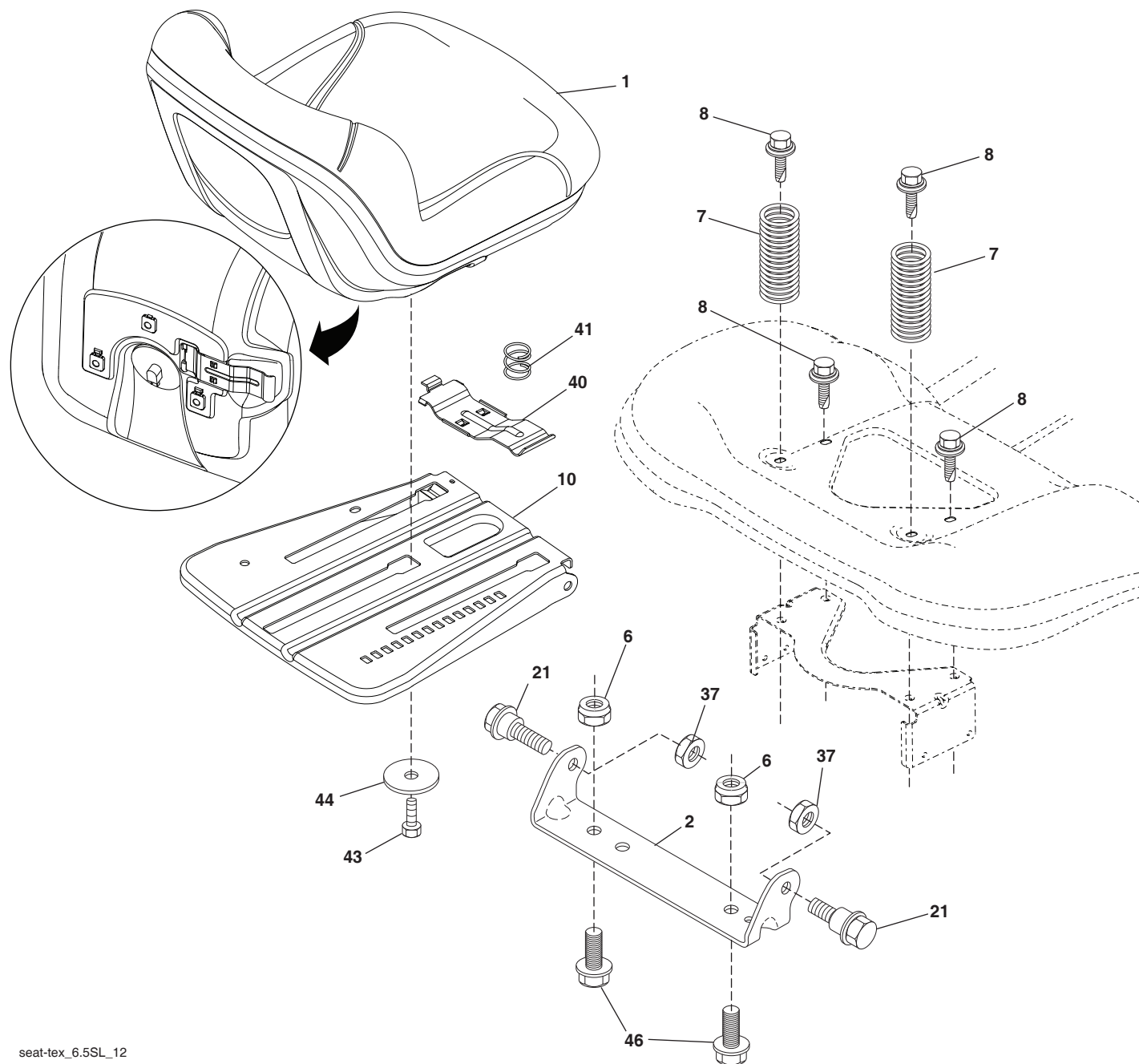

seat-tex_6.5SL_12

KEY PART NO.	NO.	DESCRIPTION
1	532 43 98-22	Seat
2	532 18 01-66	Bracket Pivot Fender
6	873 80 06-00	Nut, Lock w/Ins. 3/8-16 unc
7	587 61 33-01	Spring, Seat Cprsn
8	532 17 18-77	Bolt 5/16-18 unc x 3/4 w/Sems
10	532 19 69-77	Pan, Seat
21	587 90 78-01	Bolt, Shoulder 5/16-18 x 5/8
37	873 80 05-00	Nut, Lock 5/16-18 unc

KEY PART NO.	NO.	DESCRIPTION
40	532 19 76-61	Handle Slide Seat
41	532 19 82-00	Spring Latch Seat
43	874 76 06-12	Bolt 3/8-16 x 3/4
44	819 13 38-12	Washer 13/32 x 2-3/8 x 12 Ga.
46	588 09 04-01	Bolt 3/8-16 x 1, 1.25 OD

NOTE: All component dimensions given in U.S. inches:
1 inch = 25.4 mm.

