

ILLUSTRATED PARTS LIST

MODEL NUMBER ST 330T

PRODUCT NUMBER 961 91 00-86

MFG. ID. NUMBER 96191008601

REPAIR PARTS

AUGER HOUSING / IMPELLER ASSEMBLY

SNOW THROWER - MODEL NO. ST 330T (96191008601), PRODUCT NO. 961 91 00-86

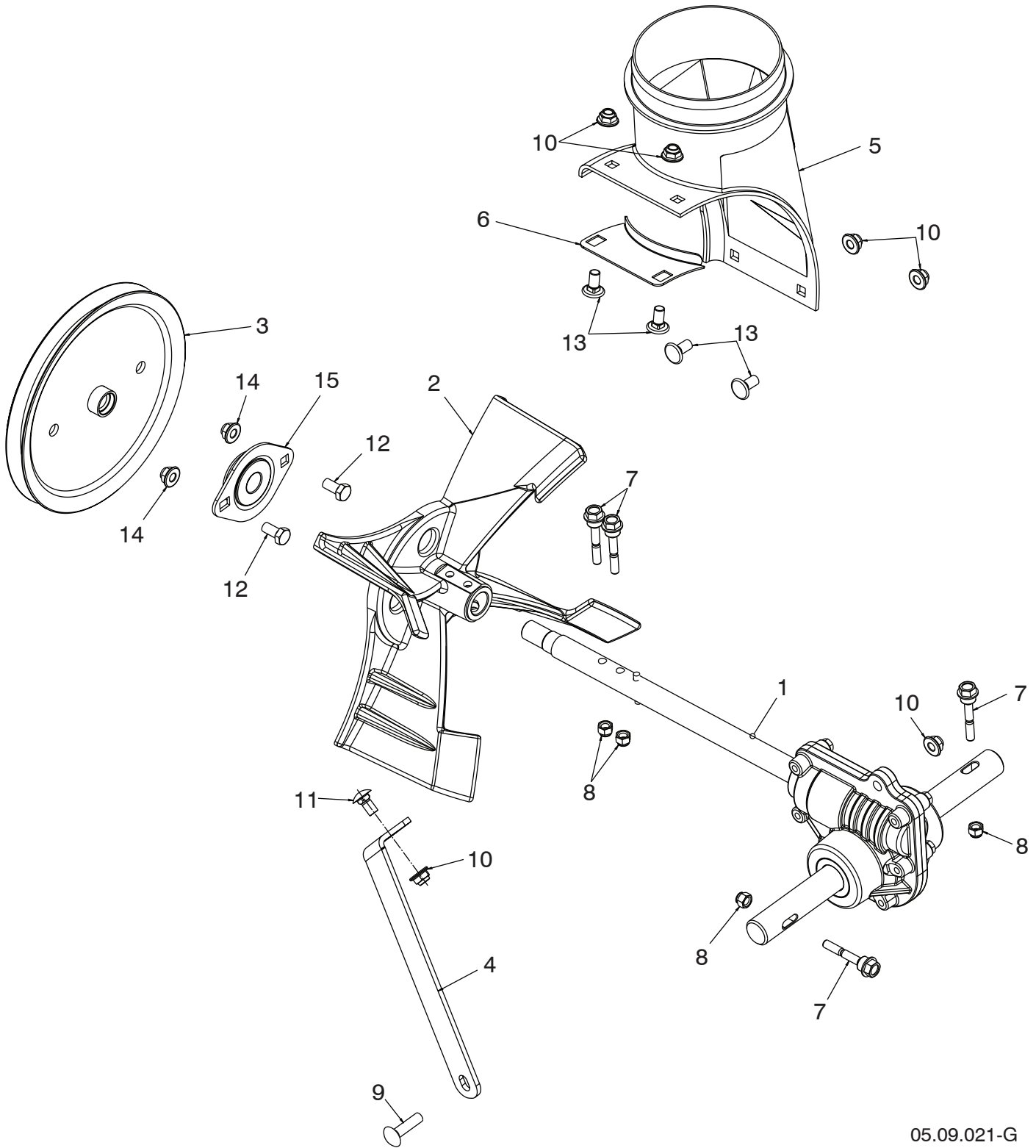

05.09.021-G

NOTE: All component dimensions given in U.S. inches. 1 inch = 25.4 mm
IMPORTANT: Use only Original Equipment Manufacturer (O.E.M.) replacement parts. Failure to do so could be hazardous, damage your snow thrower and void your warranty.

REPAIR PARTS**AUGER HOUSING / IMPELLER ASSEMBLY****SNOW THROWER - MODEL NO. ST 330T (96191008601), PRODUCT NO. 961 91 00-86**

KEY NO.	PART NO.	DESCRIPTION
1	586 71 50-01	GEARBOX AUGER CAST IRON 5/8 THREAD
2	585 19 83-03	IMPELLER CAST IRON
3	586 71 54-01	PULLEY IMPELLER 7.9 – SCREW ON
4	585 10 90-04	SUPPORT GEARBOX GREY
5	585 05 69-01	CHUTE DISCHARGE BASE
6	532 18 40-95	BRACKET CORNER DISCHARGE BASE
7	588 07 75-01	BOLT SHEAR 1/4-20
8	873 80 04-00	NUT NYLOCK 1/4-20
9	872 11 05-10	BOLT CARRIAGE 5/16-18 X 1-1/4
10	585 69 13-01	NUT FLANGE NYLOCK 5/16-18 X 1-1/4
11	585 83 20-01	BOLT CARRIAGE 5/16-18 X 5/8 - BLK
12	532 16 31-83	SCREW HEX HEAD 5/16-18 X 5/8
13	585 69 12-01	BOLT CARRIAGE WAFER HEAD 5/16-18 X 5/8 - BLK
14	532 42 79-42	NUT FLANGE NYLOCK 5/16-18
15	532 18 89-09	BEARING FLANGE

NOTE: All component dimensions given in U.S. inches. 1 inch = 25.4 mm

IMPORTANT: Use only Original Equipment Manufacturer (O.E.M.) replacement parts. Failure to do so could be hazardous, damage your snow thrower and void your warranty.

REPAIR PARTS

AUGER HOUSING / IMPELLER ASSEMBLY

SNOW THROWER - MODEL NO. ST 330T (96191008601), PRODUCT NO. 961 91 00-86

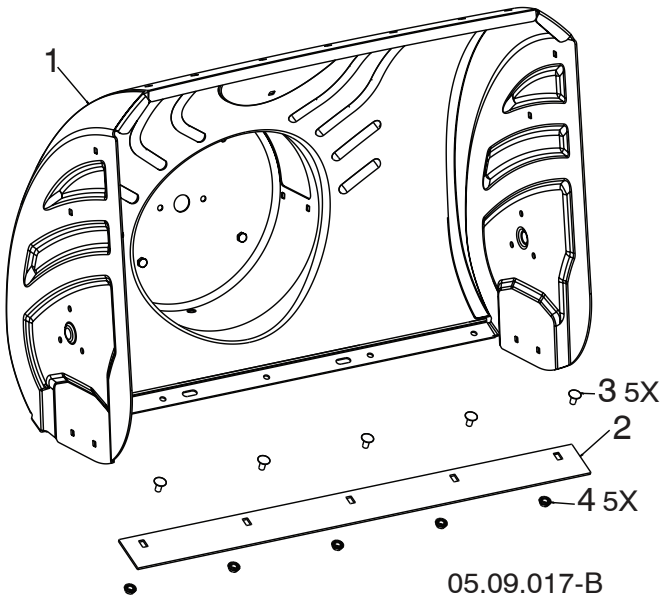

KEY NO.	PART NO.	DESCRIPTION
1	581 70 83-92	AUGER HOUSING 30 LS
2	585 04 85-02	SHAVE.PLATE 30 LS MS428
3	872 27 05-05	BOLT CARRIAGE 5/16-18 X .625
4	532 15 53-77	NUT 5/16-18 HEX TOP LOCK

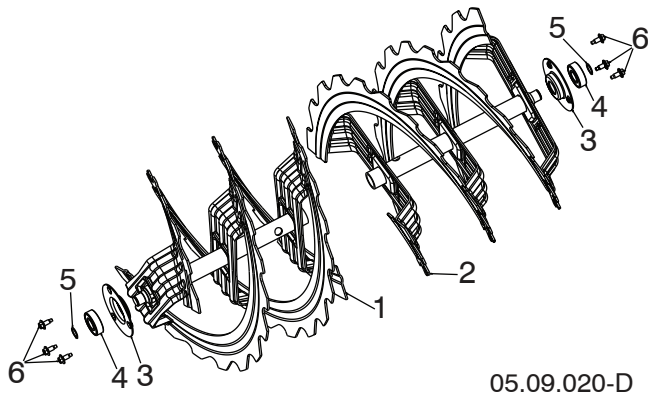

KEY NO.	PART NO.	DESCRIPTION
1	581 97 05-03	AUGER RIBBON 24 RH LS
2	581 97 06-03	AUGER RIBBON 24 LH LS
3	580 85 55-01	SUPPORT AUGER BEARING
4	532 43 76-22	BEARING IDLER 6203
5	812 00 00-28	RING RETAINING #5100-52
6	585 51 78-01	SCREW 1/4-20 X .65 W/DOG POINT

NOTE: All component dimensions given in U.S. inches. 1 inch = 25.4 mm
IMPORTANT: Use only Original Equipment Manufacturer (O.E.M.) replacement parts.
 Failure to do so could be hazardous, damage your snow thrower and void your warranty.

REPAIR PARTS

AUGER HOUSING / IMPELLER ASSEMBLY

SNOW THROWER - MODEL NO. ST 330T (96191008601), PRODUCT NO. 961 91 00-86

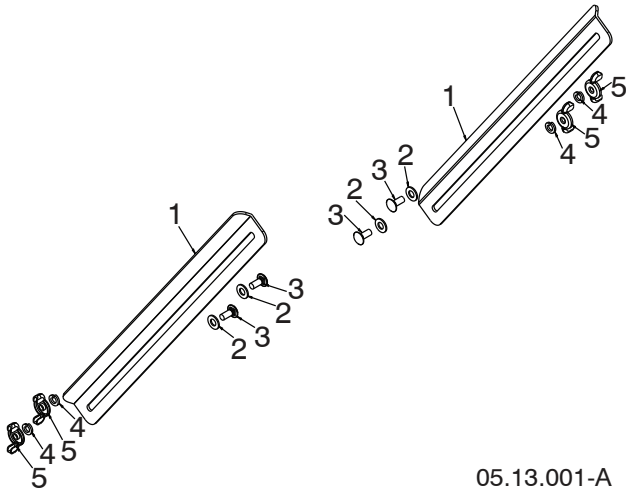

05.13.001-A

KEY NO.	PART NO.	DESCRIPTION
1	532 18 47-47	DRIFT BAR CUTTER
2	532 17 92-46	WASHER FRICTION NYLON
3	872 27 05-06	CARRIAGE BOLT 5/16-18 X .75 GR5
4	810 04 05-00	LOCKWASHER 5/16 SPLIT
5	532 12 86-38	WING NUT 5/16-18 ZINC

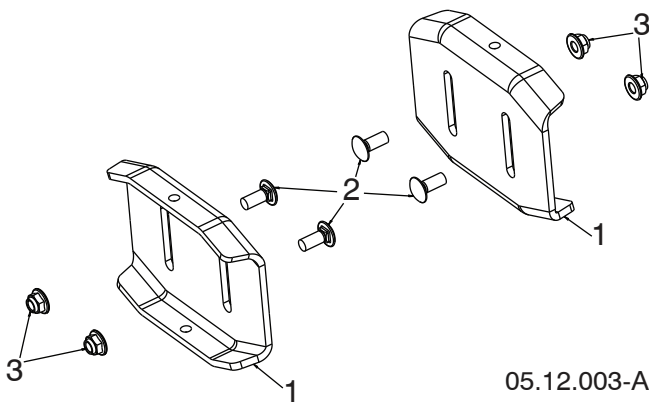

05.12.003-A

KEY NO.	PART NO.	DESCRIPTION
1	532 40 78-34	SKID PLATE
2	585 69 17-01	BOLT CARRIAGE 5/16-18 X .750 - BLK
3	585 69 13-01	NUT FLANGE NYLOCK 5/16-18 - BLK

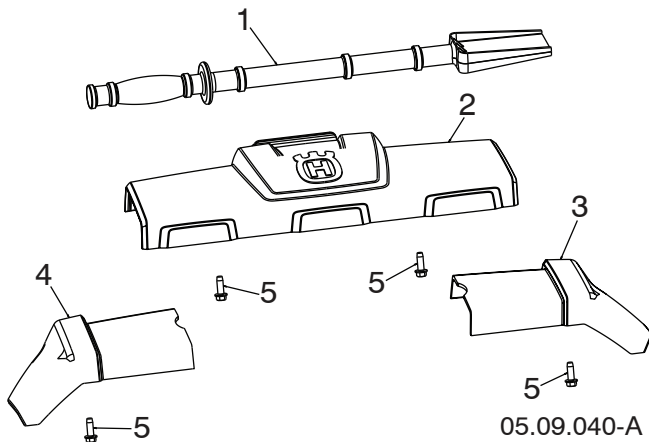

05.09.040-A

KEY NO.	PART NO.	DESCRIPTION
1	532 19 21-99	TOOL CLEANOUT
2	586 41 48-01	TRIM AUGER HOUSING FRONT ASM
3	586 33 03-02	TRIM AUGER HOUSING WING RH
4	586 33 04-02	TRIM AUGER HOUSING WING LH
5	817 67 04-12	SCREW HEX WASHER TRI-LOBE 1/4-20 X 3/4

NOTE: All component dimensions given in U.S. inches. 1 inch = 25.4 mm
IMPORTANT: Use only Original Equipment Manufacturer (O.E.M.) replacement parts.
 Failure to do so could be hazardous, damage your snow thrower and void your warranty.

REPAIR PARTS

CONTROL PANEL / DISCHARGE CHUTE

SNOW THROWER - MODEL NO. ST 330T (96191008601), PRODUCT NO. 961 91 00-86

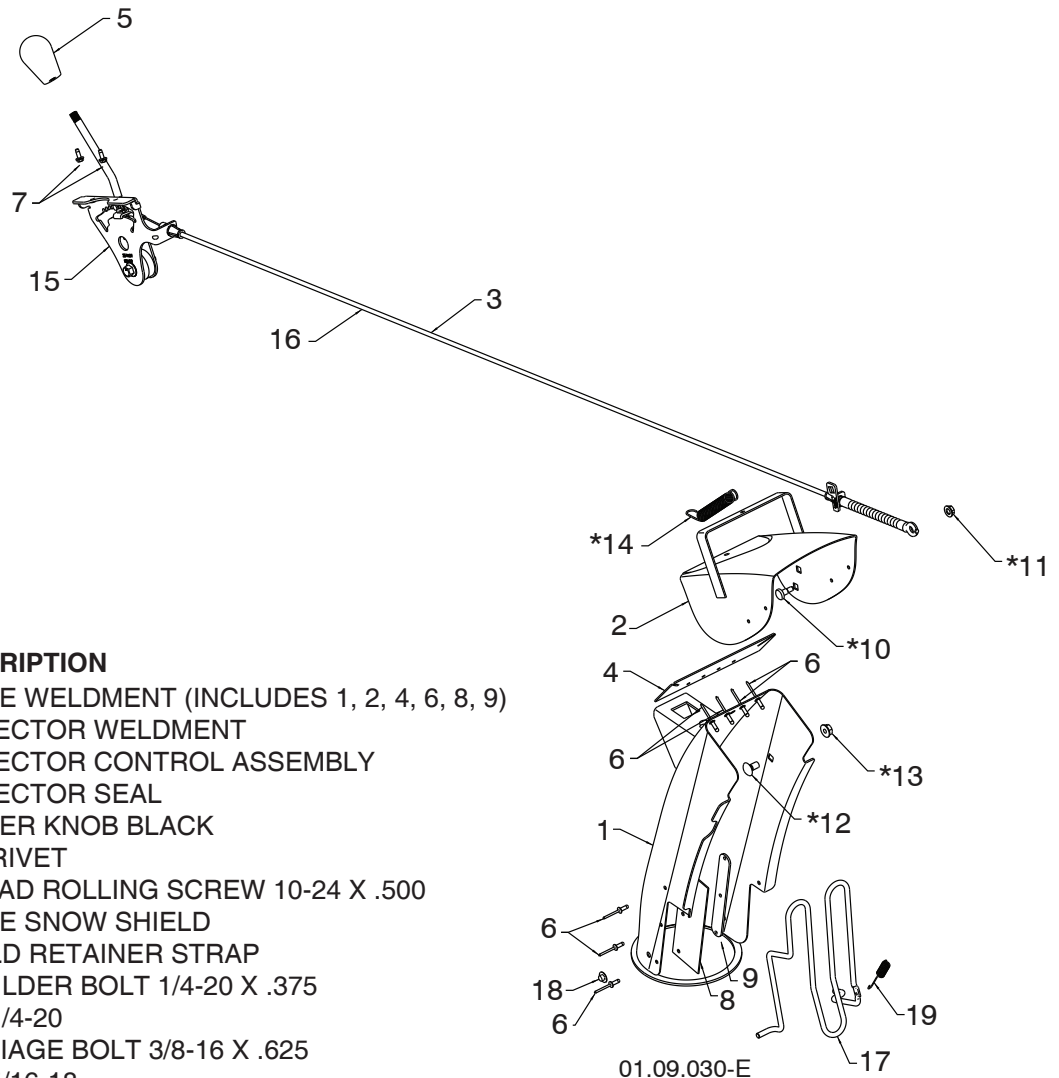

KEY NO.	PART NO.	DESCRIPTION
1	588 07 78-02	CHUTE WELDMENT (INCLUDES 1, 2, 4, 6, 8, 9)
2	-----	DEFLECTOR WELDMENT
3	587 13 31-01	DEFLECTOR CONTROL ASSEMBLY
4	-----	DEFLECTOR SEAL
5	580 67 32-01	RUBBER KNOB BLACK
6	-----	POP RIVET
7	817 54 10-08	THREAD ROLLING SCREW 10-24 X .500
8	-----	CHUTE SNOW SHIELD
9	-----	SHIELD RETAINER STRAP
*10	532 17 98-29	SHOULDER BOLT 1/4-20 X .375
*11	532 19 17-30	NUT 1/4-20
*12	585 83 20-01	CARRIAGE BOLT 3/8-16 X .625
*13	873 97 05-00	NUT 5/16-18
*14	532 18 45-05	DEFLECTOR SPRING
15	532 42 06-79	(SERVICE PART) DEFLECTOR CONTROL
16	587 03 09-01	(SERVICE PART) DEFLECTOR CABLE BLACK
17	532 43 55-82	CHUTE GUARD
18	532 05 93-49	PUSH NUT
19	532 43 56-16	SPRING

NOTE:

1. ALL ITEMS INDICATED WITH AN * ARE PROVIDED IN THE BAG OF ITEMS SHIPPED LOOSE WITH PRODUCT.
2. ITEMS 15 AND 16 ARE SERVICE PART NUMBERS TO ALLOW PURCHASE OF INDIVIDUAL ITEMS IF NECESSARY.

NOTE: All component dimensions given in U.S. inches. 1 inch = 25.4 mm
IMPORTANT: Use only Original Equipment Manufacturer (O.E.M.) replacement parts.
 Failure to do so could be hazardous, damage your snow thrower and void your warranty.

REPAIR PARTS

CONTROL PANEL / DISCHARGE CHUTE

SNOW THROWER - MODEL NO. ST 330T (96191008601), PRODUCT NO. 961 91 00-86

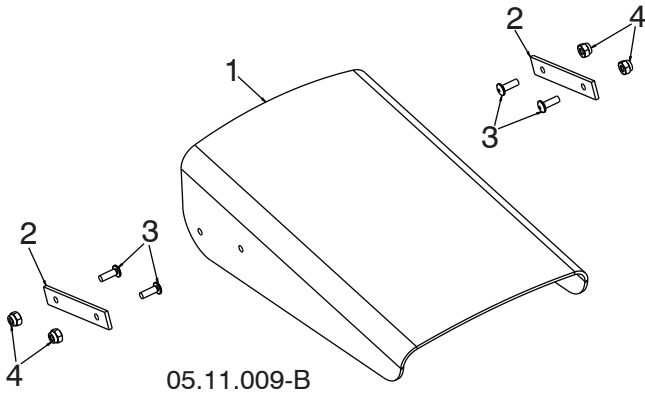

KEY NO.	PART NO.	DESCRIPTION
1	532 42 11-38	SHIELD DEFLECTOR
2	532 42 32-47	STRAP
3	586 11 80-01	SCREW MACHINE 8-32 X .50 BLK
4	586 11 81-01	NUT HEX NYLOCK 8-32 - BLK

NOTE: All component dimensions given in U.S. inches. 1 inch = 25.4 mm
IMPORTANT: Use only Original Equipment Manufacturer (O.E.M.) replacement parts.
Failure to do so could be hazardous, damage your snow thrower and void your warranty.

REPAIR PARTS

CONTROL PANEL / DISCHARGE CHUTE

SNOW THROWER - MODEL NO. ST 330T (96191008601), PRODUCT NO. 961 91 00-86

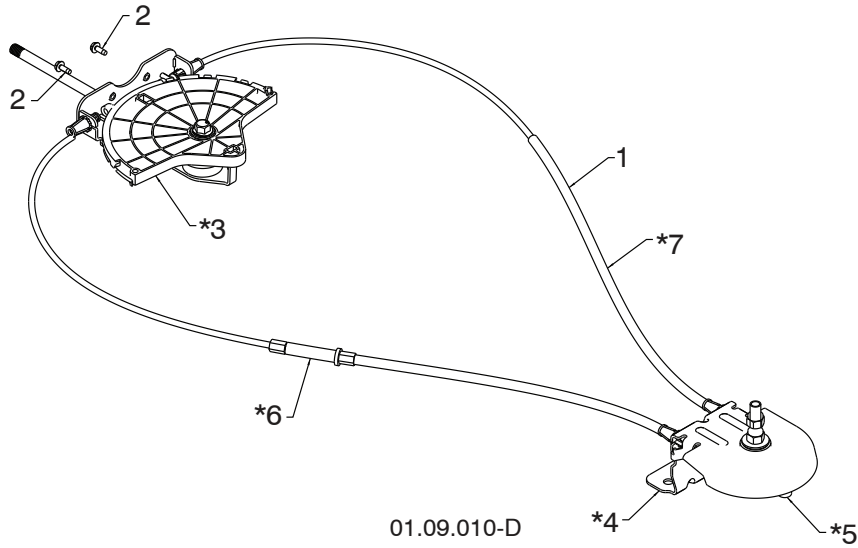

KEY NO.	PART NO.	DESCRIPTION
1	532 42 82-72	LEVER/CABLE ROTATOR ASSEMBLY
2	817 54 10-08	THREAD ROLLING SCREW 10-24 X .500
*3	532 42 06-78	ROTATOR HEAD
*4	585 19 92-01	ROTATOR PIVOT BRACKET
*5	532 42 06-75	PULLEY PIVOT
*6	532 42 82-73	CABLE ASSEMBLY ADJUSTABLE
*7	532 42 83-10	CABLE ASSEMBLY HEAT SHIELD

NOTES:

1. ITEMS INDICATED WITH AN * ARE LISTED AS REFERENCE FOR SERVICE PARTS ONLY.

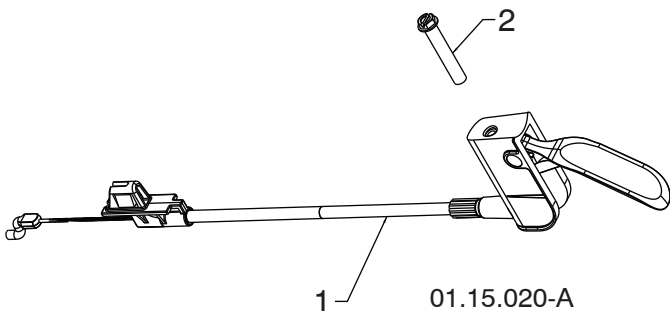

KEY NO.	PART NO.	DESCRIPTION
1	580 84 31-03	STEER CABLE
2	874 04 10-24	SCREW 10-24 X 1.50

NOTE: All component dimensions given in U.S. inches. 1 inch = 25.4 mm
IMPORTANT: Use only Original Equipment Manufacturer (O.E.M.) replacement parts. Failure to do so could be hazardous, damage your snow thrower and void your warranty.

REPAIR PARTS

CONTROL PANEL / DISCHARGE CHUTE

SNOW THROWER - MODEL NO. **ST 330T** (96191008601), PRODUCT NO. 961 91 00-86

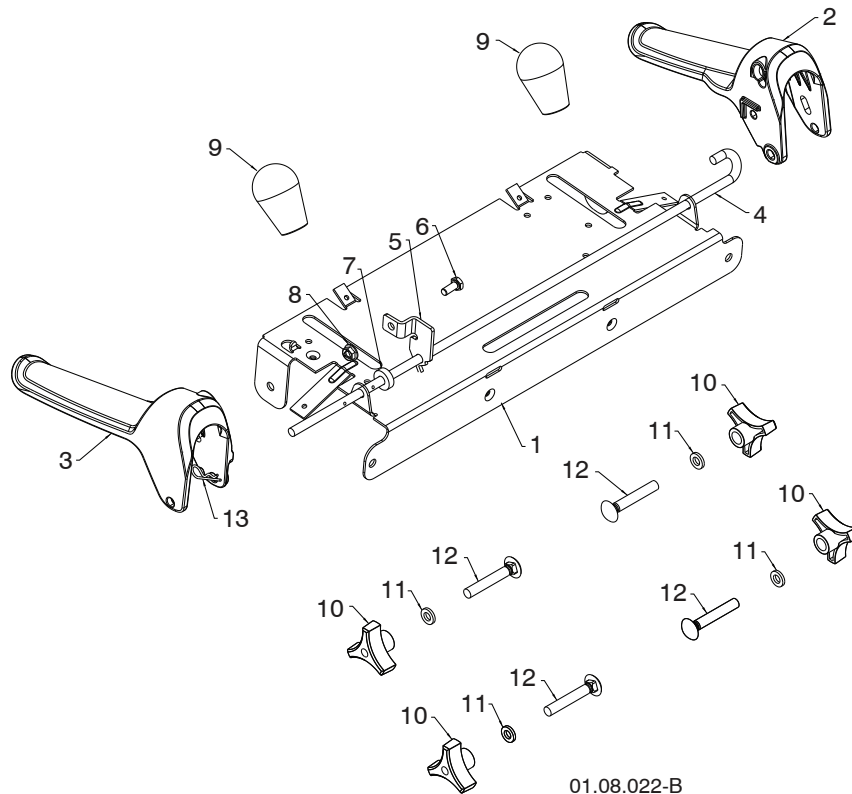

KEY NO.	PART NO.	DESCRIPTION
1	585 19 88-02	CONTROL PANEL
2	581 77 98-01	LH CONTROL LEVER
3	581 77 97-01	RH CONTROL LEVER
4	584 80 90-01	INTERLOCK CONTROL ROD
5	585 00 47-03	INTERLOCK BRACKET
6	874 78 04-10	1/4-20 X .625 HEX HEAD SCREW
7	532 42 16-13	SPACER
8	532 08 83-49	1/4-20 FLANGE NUT (TOP LOCK)
9	580 67 32-01	KNOB SOFT TOUCH
10	532 17 88-99	HANDLE KNOB
11	819 13 13-16	3/8 WASHER
12	872 12 06-18	CARRIAGE BOLT 3/8-16 X 2.25
13	532 16 96-75	RETAINER

NOTE: All component dimensions given in U.S. inches. 1 inch = 25.4 mm
IMPORTANT: Use only Original Equipment Manufacturer (O.E.M.) replacement parts. Failure to do so could be hazardous, damage your snow thrower and void your warranty.

REPAIR PARTS

HANDLES

SNOW THROWER - MODEL NO. ST 330T (96191008601), PRODUCT NO. 961 91 00-86

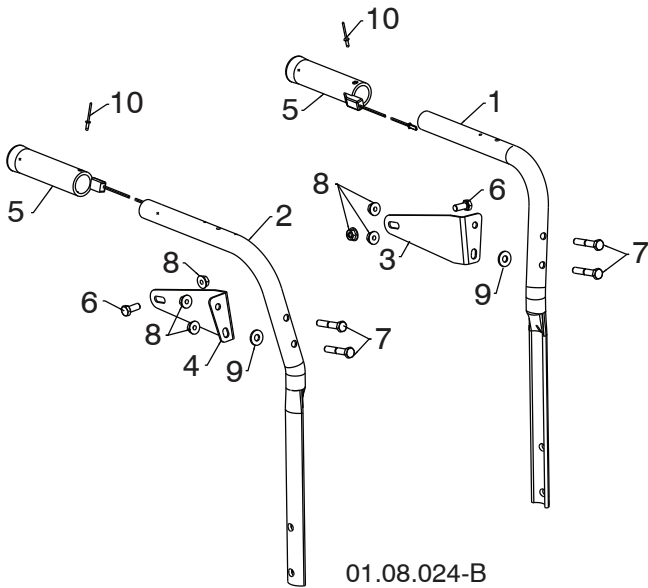

KEY NO.	PART NO.	DESCRIPTION
1	532 42 17-08	PLOW HANDLE LH
2	532 42 17-09	PLOW HANDLE RH
3	532 42 91-48	PANEL BRACKET LH
4	532 42 91-49	PANEL BRACKET RH
5	532 41 45-15	HEATED HANDLE GRIP
6	874 78 05-12	SCREW 5/16-18 X .750
7	874 78 05-28	SCREW 5/16-18 X 1.75
8	532 75 11-53	NUT 5/16-18
9	532 15 54-15	WASHER
10	532 17 87-75	POP RIVET 1/8

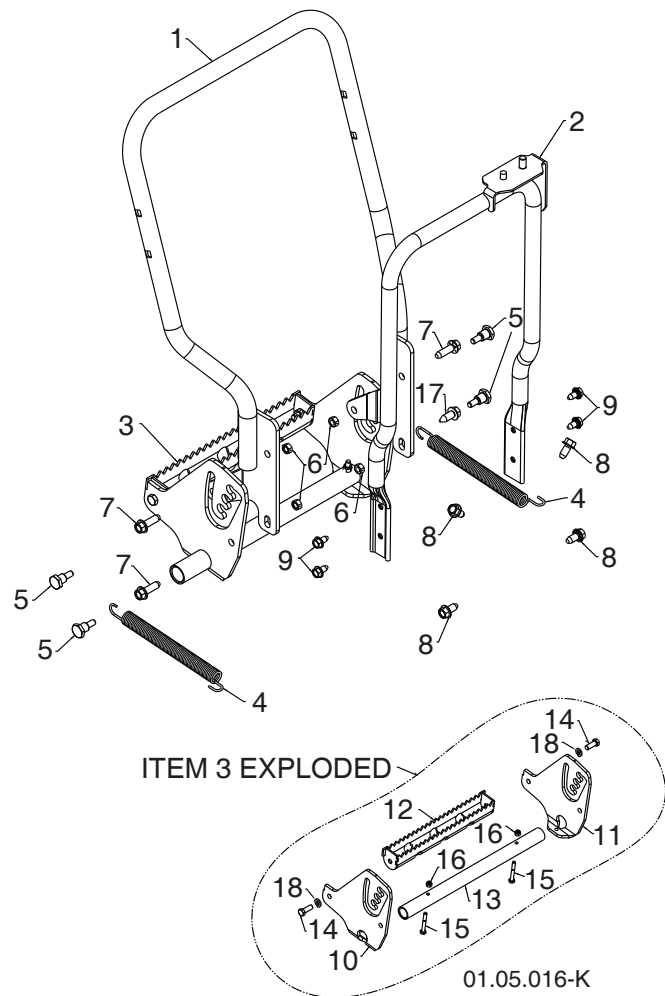

KEY NO.	PART NO.	DESCRIPTION
1	580 75 04-02	LOWER TUBE WELDMENT GRAY
2	532 42 75-13	PIVOT SUPPORT WELDMENT
3	580 79 03-01	FOOT ADJUST ASSEMBLY
4	532 44 32-48	EXTENSION SPRING
5	532 44 36-60	SHOULDER BOLT 5/16-18
6	873 93 05-00	LOCKNUT 5/16-18
7	817 06 06-20	SCREW 3/8-16 X 1.25
8	817 00 06-12	SCREW 3/8-16 X .750
9	817 00 05-10	SCREW 5/16-18 HEX WHS HD LK SERR
10	580 94 99-01	RIGHT GUIDE PLATE
11	580 94 99-02	LEFT GUIDE PLATE
12	580 95 00-01	FOOT ADJUST PEDAL
13	580 95 01-01	ANTI-ROTATE TUBE
14	874 78 06-16	CAPSCREW 3/8-16 X 1.00
15	874 76 04-32	CAPSCREW 1/4-20 X 2.00
16	873 80 04-00	NUT NYLOCK 1/4-20
17	817 06 06-16	SCREW 3/8-16 X 1.00
18	810 04 06-00	LOCKWASHER 3/8

NOTE: All component dimensions given in U.S. inches. 1 inch = 25.4 mm
IMPORTANT: Use only Original Equipment Manufacturer (O.E.M.) replacement parts. Failure to do so could be hazardous, damage your snow thrower and void your warranty.

REPAIR PARTS

HANDLES

SNOW THROWER - MODEL NO. ST 330T (96191008601), PRODUCT NO. 961 91 00-86

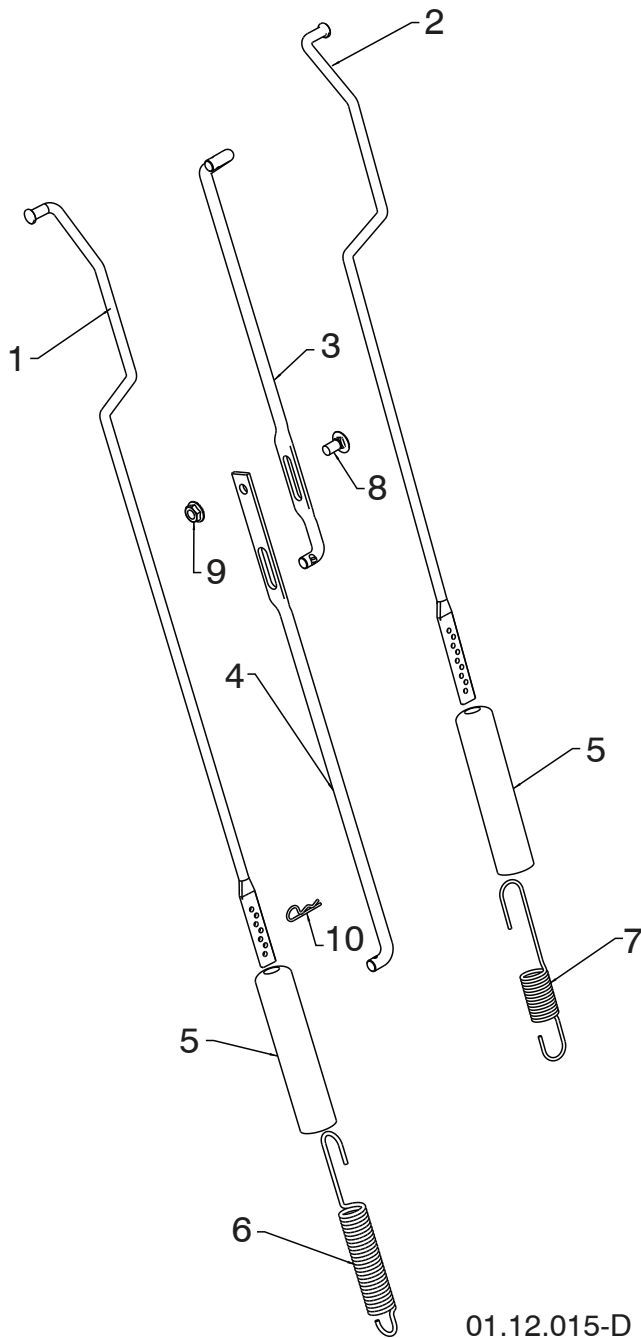

KEY NO.	PART NO.	DESCRIPTION
1	584 80 89-01	ROD IMPELLER CONTROL
2	584 80 88-01	ROD TRACTION CONTROL
3	532 18 77-82	SHIFTER ROD TOP
4	532 18 77-84	SHIFTER ROD BOTTOM
5	532 18 04-47	SPRING SLEEVE
6	580 79 62-01	SPRING CONTROL ROD
7	580 80 21-01	SPRING TRACTION ROD
8	872 27 05-05	CARRIAGE BOLT 5/16-18 X .75
9	532 15 53-77	NUT 5/16-28
10	532 16 96-75	RETAINER

NOTE: HOOK TRACTION ROD SPRING IN HOLE 5
HOOK IMPELLER ROD SPRING IN HOLE 5

NOTE: All component dimensions given in U.S. inches. 1 inch = 25.4 mm
IMPORTANT: Use only Original Equipment Manufacturer (O.E.M.) replacement parts.
Failure to do so could be hazardous, damage your snow thrower and void your warranty.

REPAIR PARTS

HANDLES

SNOW THROWER - MODEL NO. ST 330T (96191008601), PRODUCT NO. 961 91 00-86

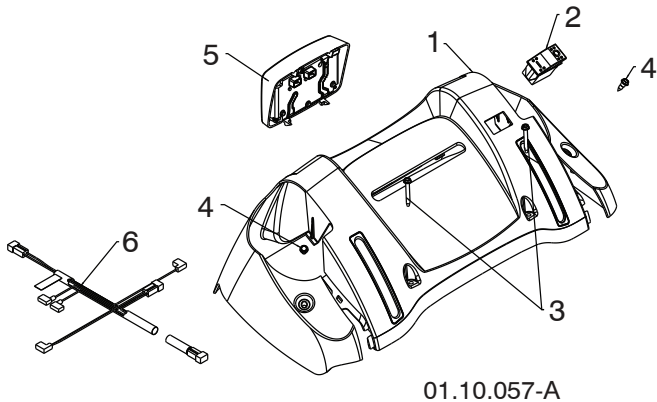

KEY NO.	PART NO.	DESCRIPTION
1	532 42 13-51	CONSOLE PANEL
2	532 41 77-60	SWITCH GRIP
3	532 17 52-62	SCREW HX WHSR HEAD 10-24 X 1.25
4	532 18 44-71	SCREW SHOULDER 10-24 X .62
5	581 68 42-01	LED LIGHT DUAL STAGE GRAY
6	580 62 56-01	WIRE HARNESS FLOOD / LED HEATED

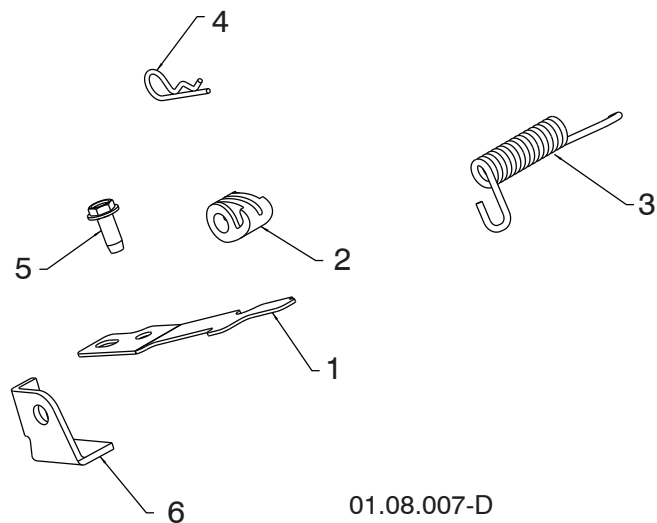

KEY NO.	PART NO.	DESCRIPTION
1	532 41 62-88	INTERLOCK SPRING
2	532 44 52-91	INTERLOCK CAM
3	532 44 32-15	TORSION SPRING
4	532 16 96-75	RETAINER
5	817 06 04-10	SCREW 1/4-20 X .625
6	532 42 18-14	INTERLOCK STOP

NOTE: All component dimensions given in U.S. inches. 1 inch = 25.4 mm
IMPORTANT: Use only Original Equipment Manufacturer (O.E.M.) replacement parts.
 Failure to do so could be hazardous, damage your snow thrower and void your warranty.

REPAIR PARTS

DRIVE

SNOW THROWER - MODEL NO. ST 330T (96191008601), PRODUCT NO. 961 91 00-86

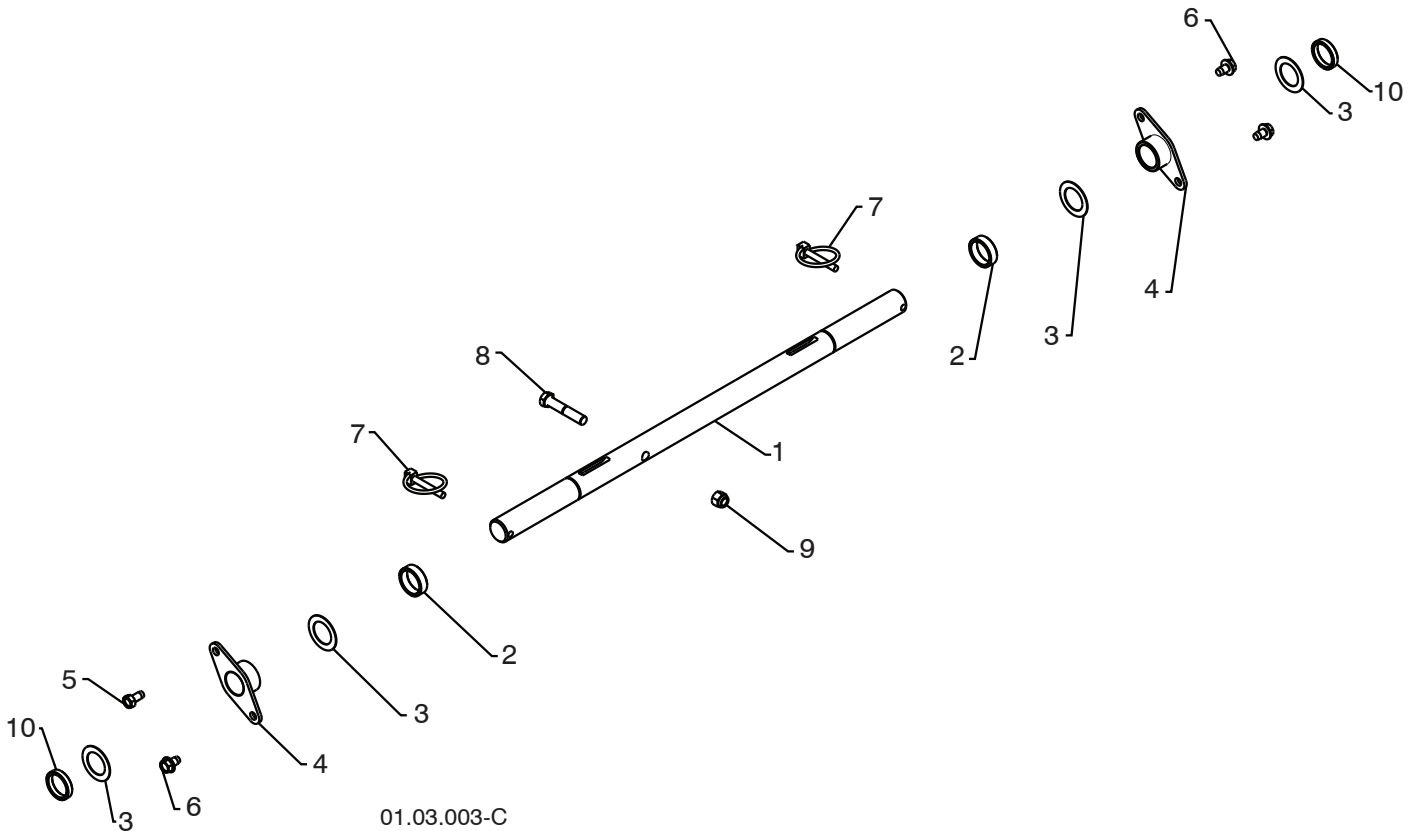

KEY NO.	PART NO.	DESCRIPTION
1	532 40 43-08	AXLE SHAFT
2	532 18 77-94	SPACER
3	532 44 49-49	THRUST WASHER
4	532 17 98-30	BEARING
5	532 14 63-15	SCREW 5/16-18 X .625
6	817 49 05-08	BOLT 5/16-18 X .500
7	532 15 54-43	CLIK PIN
8	874 78 06-32	SCREW 3/8-16 X 2.00
9	873 80 06-00	NUT 3/8-16
10	585 05 71-01	.235 SPACER

NOTE: All component dimensions given in U.S. inches. 1 inch = 25.4 mm
IMPORTANT: Use only Original Equipment Manufacturer (O.E.M.) replacement parts. Failure to do so could be hazardous, damage your snow thrower and void your warranty.

REPAIR PARTS

DRIVE

SNOW THROWER - MODEL NO. ST 330T (96191008601), PRODUCT NO. 961 91 00-86

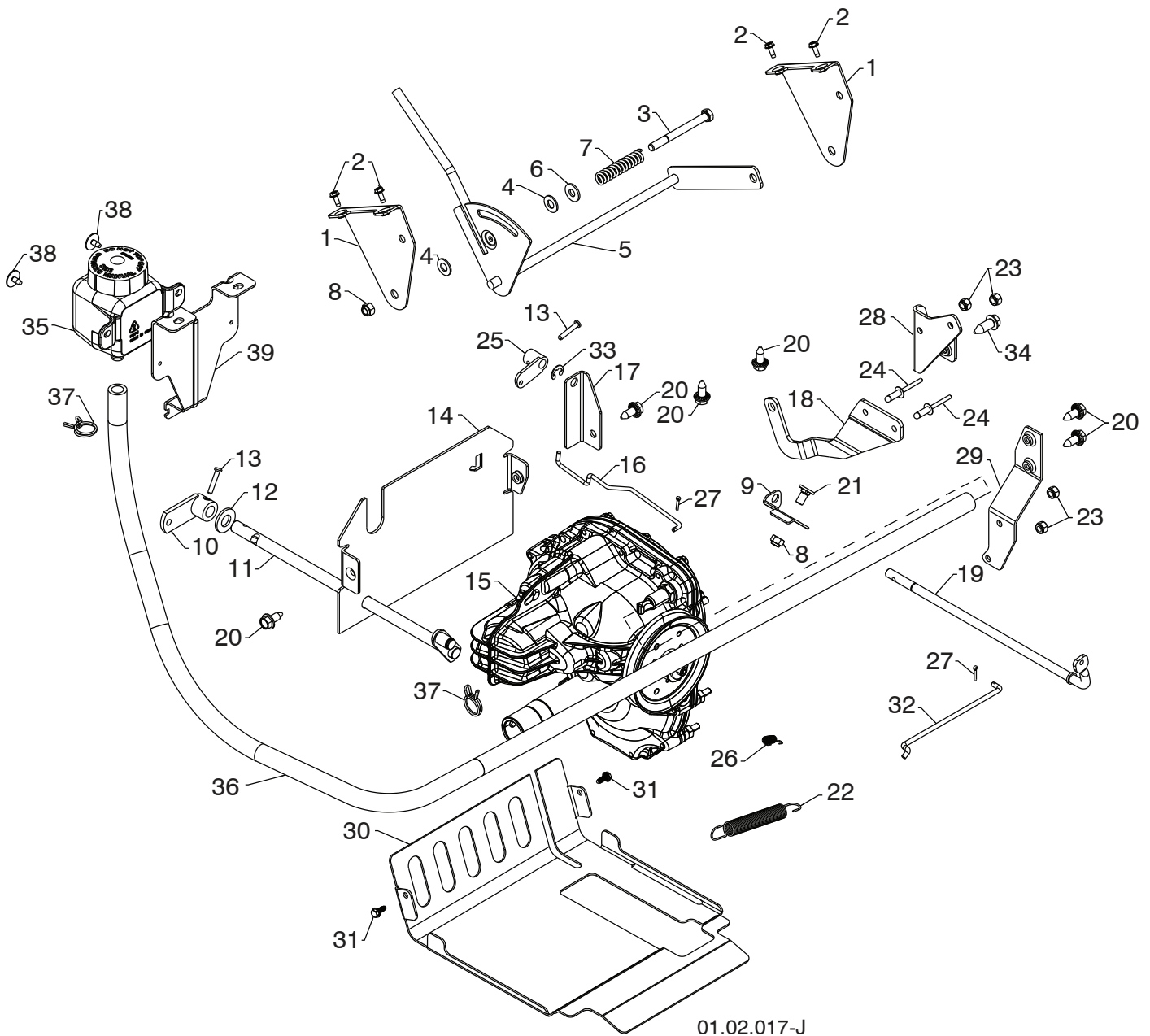

01.02.017-J

NOTE: All component dimensions given in U.S. inches. 1 inch = 25.4 mm
IMPORTANT: Use only Original Equipment Manufacturer (O.E.M.) replacement parts.
Failure to do so could be hazardous, damage your snow thrower and void your warranty.

REPAIR PARTS**DRIVE****SNOW THROWER - MODEL NO. ST 330T (96191008601), PRODUCT NO. 961 91 00-86**

KEY NO.	PART NO.	DESCRIPTION
1	532 44 33-44	SHIFT BRACKET
2	817 54 10-08	THREAD ROLLING SCREW 10-24 X .500
3	874 76 05-52	SCREW 5/16-18 X 3.25
4	532 17 92-46	PLASTIC WASHER
5	532 19 20-01	SHIFT ASSEMBLY
6	532 15 54-15	WASHER
7	532 19 21-95	FRICTION SPRING
8	873 80 05-00	NUT 5/16-18
9	532 42 98-03	FRONT CLUTCH BRACKET
10	532 44 31-91	CONTROL ARM
11	532 42 75-42	CONTROL SHAFT
12	532 18 89-06	WASHER
13	532 19 85-80	CLEVIS PIN
14	580 75 06-02	REAR PLATE
15	532 44 50-58	TRANSMISSION
16	532 19 32-56	ROD
17	532 42 98-05	REAR CLUTCH BRACKET
18	532 18 77-87	CONTROL ASM
19	532 19 82-51	CLUTCH SHAFT
20	532 42 88-67	SCREW 5/16-18 X .750
21	532 18 03-55	CARRIAGE BOLT 5/16-18 X .625
22	532 17 88-28	BRAKE SPRING
23	873 80 04-00	NUT 1/4-20
24	532 19 19-95	POP RIVET 1/4 X .475
25	532 19 82-49	CLUTCH ARM
26	532 19 28-73	TRACTION SPRING
27	532 70 02-79	RETAINER CLIP
28	532 40 78-58	ANTI-ROTATE BRACKET
29	532 41 47-71	TORQUE STRAP BRACKET
30	585 16 68-02	BOTTOM PAN
31	532 44 33-84	SCREW 10-32 X .500
32	532 44 62-93	CLUTCH ROD
33	532 42 82-88	E-RING .375
34	817 06 05-16	SCREW 5/16-18 X 1.00
35	574 81 13-01	REMOTE EXPANSION TANK
36	580 75 08-01	HOSE EXPANSION TANK
37	532 44 52-98	SPRING HOSE CLAMP .795
38	532 18 92-41	SCREW 10-24 X 1/2 HEX WASHER HEAD
39	580 75 09-02	BRACKET MTG EXPANSION TANK

NOTE: All component dimensions given in U.S. inches. 1 inch = 25.4 mm
IMPORTANT: Use only Original Equipment Manufacturer (O.E.M.) replacement parts.
 Failure to do so could be hazardous, damage your snow thrower and void your warranty.

REPAIR PARTS

CHASSIS / ENGINE / PULLEYS

SNOW THROWER - MODEL NO. ST 330T (96191008601), PRODUCT NO. 961 91 00-86

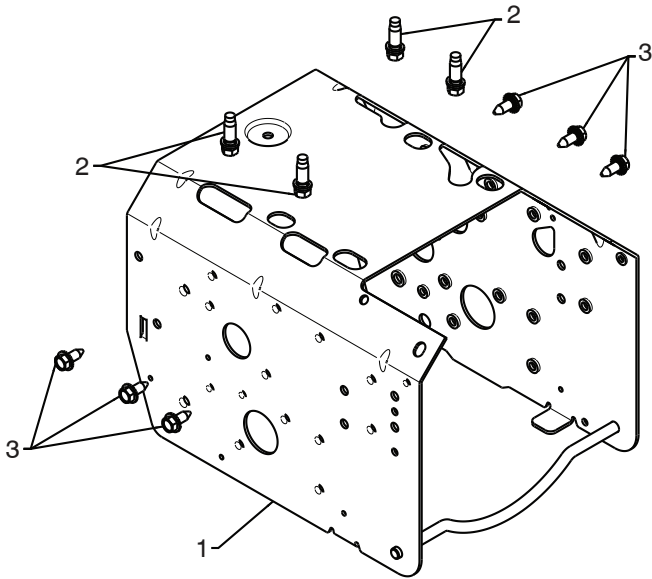

01.00.033-A

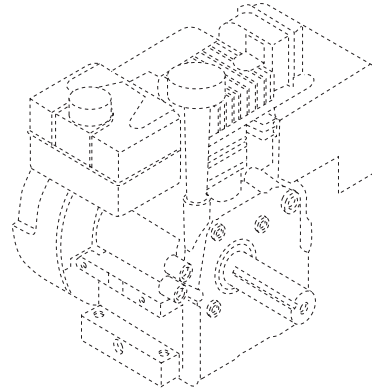

KEY NO.	PART NO.	DESCRIPTION
--	580 42 67-04	COMPLETE LCT ENGINE PW2HK181250781D
1	532 42 92-03	FRAME
2	532 15 04-06	BOLT 3/8-16
3	532 42 88-67	SCREW 5/16-18 X .750

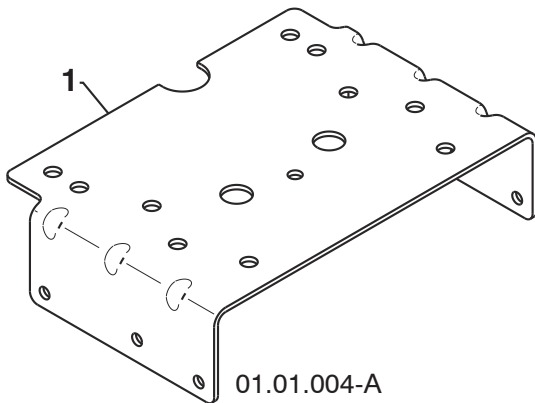

01.01.004-A

KEY NO.	PART NO.	DESCRIPTION
1	532 42 92-69	ENGINE MOUNTING PLATE

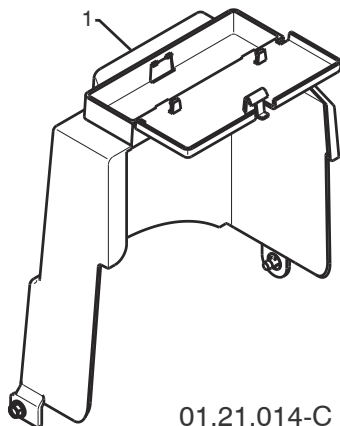

01.21.014-C

KEY NO.	PART NO.	DESCRIPTION
1	532 42 86-85	COVER ASSEMBLY

NOTE: All component dimensions given in U.S. inches. 1 inch = 25.4 mm
IMPORTANT: Use only Original Equipment Manufacturer (O.E.M.) replacement parts. Failure to do so could be hazardous, damage your snow thrower and void your warranty.

REPAIR PARTS

CHASSIS / ENGINE / PULLEYS

SNOW THROWER - MODEL NO. ST 330T (96191008601), PRODUCT NO. 961 91 00-86

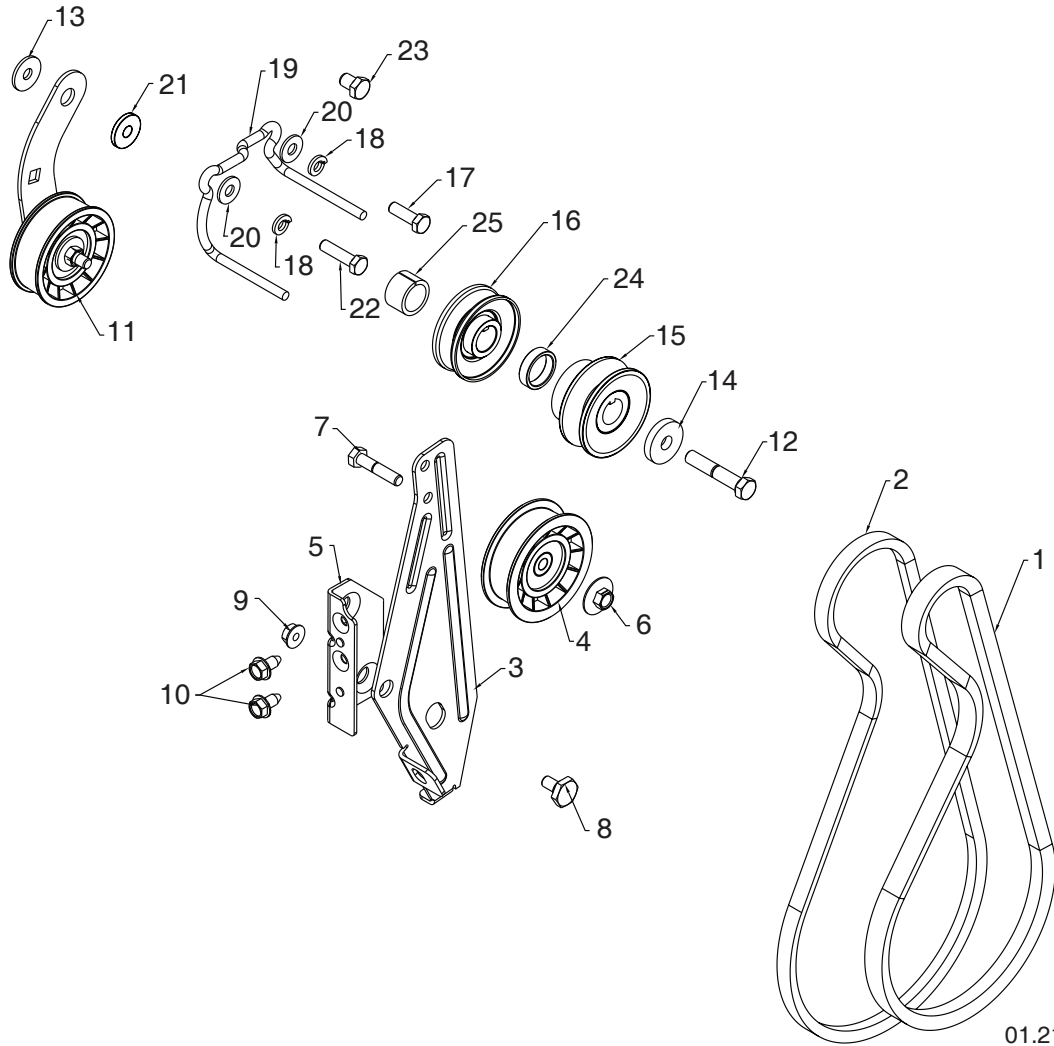

01.21.027-C

KEY NO.	PART NO.	DESCRIPTION	KEY NO.	PART NO.	DESCRIPTION
1	532 41 98-88	IMPELLER BELT	13	532 05 92-89	WASHER
2	532 42 84-54	TRACTION BELT	14	819 13 20-05	WASHER
3	584 23 24-02	IDLER ARM BRACKET	15	586 05 08-01	PULLEY ENGINE IMPELLER
4	532 18 05-23	IDLER PULLEY	16	532 18 04-78	PULLEY ENGINE TRACTION
5	585 28 49-01	IDLER BRACKET	17	874 61 05-16	SCREW 5/16-24 X 1.00 GR5
6	532 42 65-89	NUT 5/16-18	18	810 04 05-00	LOCKWASER 5/16
7	874 78 05-24	SCREW 5/16-18 X 1.50 GR5	19	585 54 05-01	BELT GUIDE
8	532 42 42-97	SHOULDER BOLT 5/16-18 X .50 GR2	20	532 15 54-15	WASHER FLAT .335 X .787 X .079
9	532 75 11-53	NUT 5/16-18 LOCK	21	587 34 37-01	IDLER BUSHING
10	817 00 05-10	SCREW 5/16-18 X .625	22	874 61 05-20	SCREW 5/16-24 X 1.25 GR5
11	585 23 84-01	TRACTION IDLER BRACKET ASM	23	874 76 06-08	SCREW 3/8-16 X .500 GR2
12	532 17 96-17	SCREW 3/8-24 X 2.00	24	532 40 94-75	SPACER ENGINE PULLEY
			25	532 13 70-57	SPACER

NOTE: All component dimensions given in U.S. inches. 1 inch = 25.4 mm
IMPORTANT: Use only Original Equipment Manufacturer (O.E.M.) replacement parts.
 Failure to do so could be hazardous, damage your snow thrower and void your warranty.

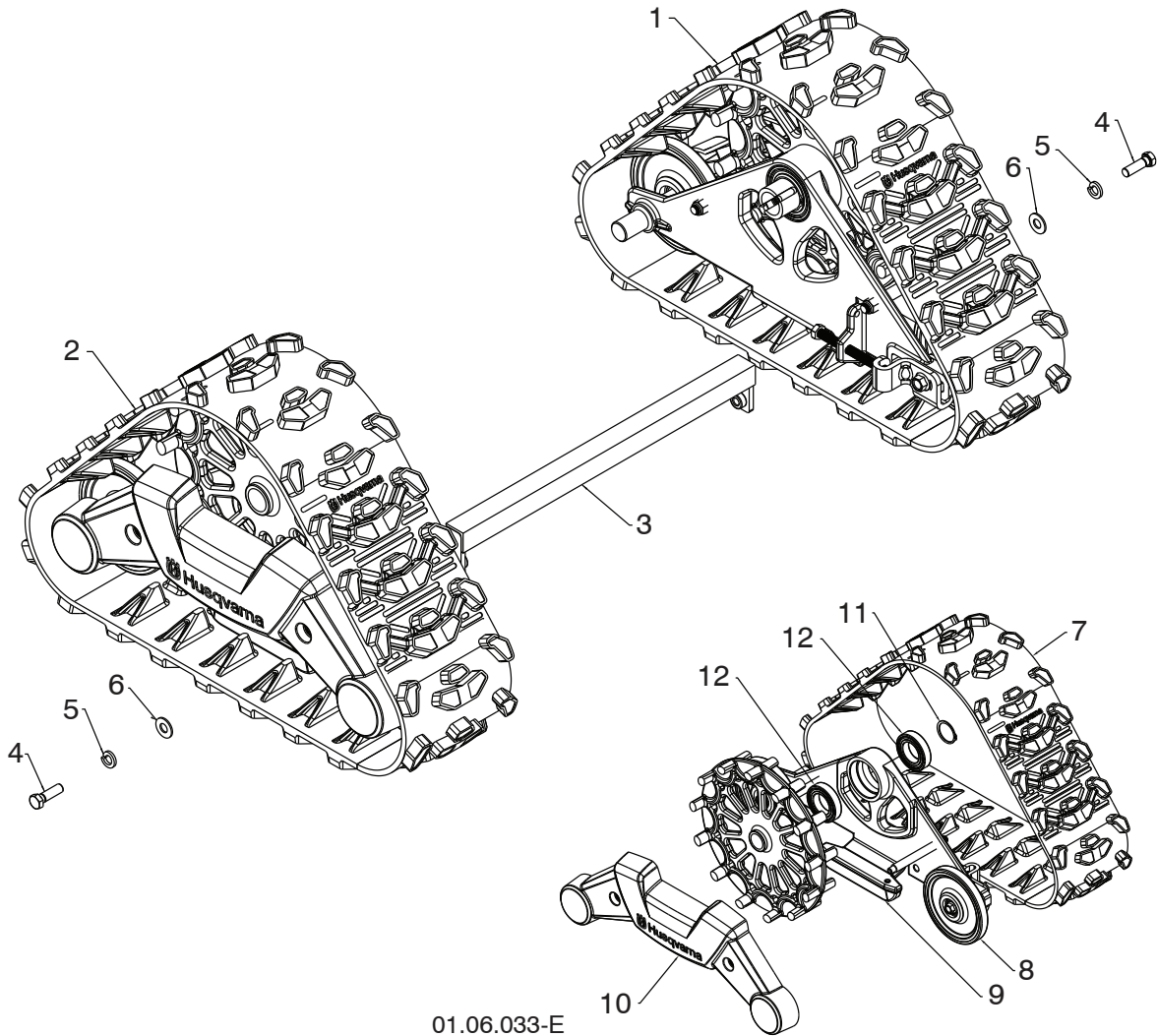

01.06.033-E

KEY NO.	PART NO.	DESCRIPTION
1	586 99 02-01	TRACK ASSEMBLY LH
2	586 99 02-02	TRACK ASSEMBLY RH
3	580 78 99-01	SUPPORT BRACE ASSEMBLY
4	874 78 06-20	CAPSCREW 5/16-18 X 1.25
5	532 85 02-63	LOCKWASHER 3/8
6	819 13 14-16	FLAT WASHER
7	586 99 64-01	TRACK BELT
8	580 81 20-01	IDLER WHEEL
9	586 99 68-01	TRACK GUIDE
10	586 99 69-01	COVER
11	581 47 92-01	SNAP RING
12	581 47 91-01	BALL BEARING

NOTE: All component dimensions given in U.S. inches. 1 inch = 25.4 mm
IMPORTANT: Use only Original Equipment Manufacturer (O.E.M.) replacement parts. Failure to do so could be hazardous, damage your snow thrower and void your warranty.

REPAIR PARTS

TRACKS

SNOW THROWER - MODEL NO. ST 330T (96191008601), PRODUCT NO. 961 91 00-86

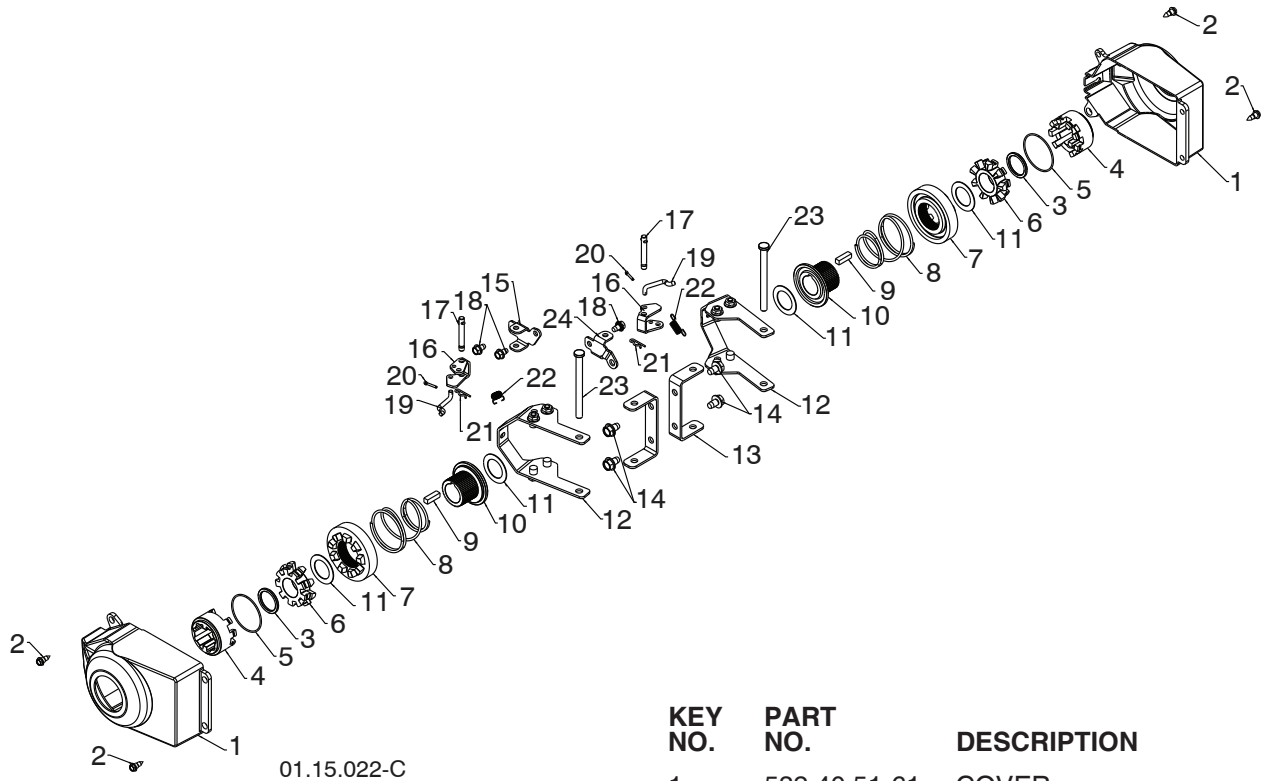

KEY NO.	PART NO.	DESCRIPTION
1	532 40 51-61	COVER
2	532 18 44-71	SHOULDER SCREW
3	585 05 70-01	SPACER
4	585 05 68-01	WHEEL DRIVER
5	532 18 24-66	RETAINER RING
6	532 18 76-22	WHEEL LOBE
7	581 64 49-01	CLUTCH SLIDE
8	585 35 16-01	SPRING
9	532 18 92-82	SQUARE KEY
10	581 64 51-01	AXLE LOBE
11	532 44 49-49	THRUST WASHER
12	584 92 79-02	STEERING YOKE
13	532 18 41-97	STEERING BRACKET
14	817 49 05-08	SCREW 5/16-18 X .50
15	532 19 95-11	PIVOT BRACKET
16	532 19 95-18	BELLCRANK
17	532 18 18-47	BELLCRANK PIN
18	817 60 04-06	SCREW 1/4-20 X .375
19	532 40 50-77	STEERING LINK
20	532 70 02-79	RETAINER
21	532 08 51-79	RETAINER
22	532 19 38-85	SPRING
23	532 18 20-15	LEVER PIN
24	532 19 95-12	PIVOT BRACKET

NOTE: All component dimensions given in U.S. inches. 1 inch = 25.4 mm
IMPORTANT: Use only Original Equipment Manufacturer (O.E.M.) replacement parts.
 Failure to do so could be hazardous, damage your snow thrower and void your warranty.

REPAIR PARTS

TRACKS

SNOW THROWER - MODEL NO. ST 330T (96191008601), PRODUCT NO. 961 91 00-86

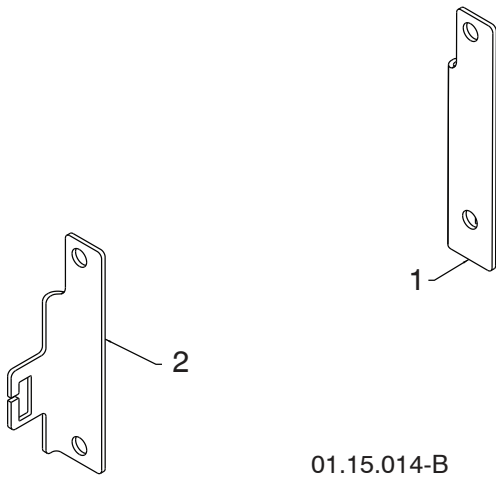

KEY NO.	PART NO.	DESCRIPTION
1	532 44 33-22	STEER CABLE BRACKET LH
2	532 43 84-45	STEER CABLE BRACKET RH

NOTE: All component dimensions given in U.S. inches. 1 inch = 25.4 mm
IMPORTANT: Use only Original Equipment Manufacturer (O.E.M.) replacement parts.
Failure to do so could be hazardous, damage your snow thrower and void your warranty.

REPAIR PARTS

BAG OF PARTS

SNOW THROWER - MODEL NO. ST 330T (96191008601), PRODUCT NO. 961 91 00-86

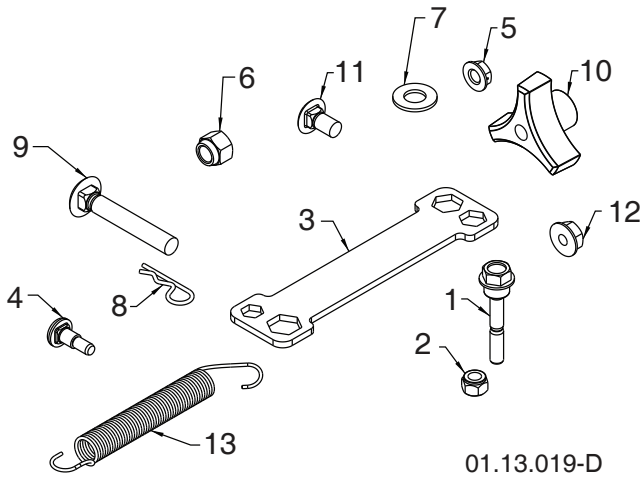

KEY NO.	PART NO.	DESCRIPTION
1	588 07 75-01	BOLT SHEAR 1/4-20
2	873 80 04-00	NUT NYLOCK 1/4-20
3	532 42 91-12	WRENCH
4	532 17 98-29	BOLT SHOULDER
5	532 19 17-30	NUT HEX FL 1/4-20
6	873 80 06-00	NUT NYLOCK 3/8-16
7	819 13 13-16	WASHER FLAT 3/8 SAE
8	532 16 96-75	RETAINER HAIRPIN
9	872 12 06-18	BOLT 3/8-16 X 2.25
10	532 17 88-99	KNOB 3/8-16 TRI LOBE
11	585 83 20-01	BOLT BLACK 5/16-18 X 5/8
12	873 97 05-00	NUT FL LOCK 5/16-18
13	532 18 45-05	SPRING DEFLECT CHUTE
--	588 55 63-01	BAG OF HARDWARE

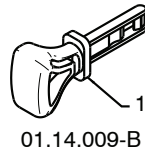

KEY NO.	PART NO.	DESCRIPTION
1	532 44 30-59	SAFETY IGNITION KEY KIT

NOTE: All component dimensions given in U.S. inches. 1 inch = 25.4 mm
IMPORTANT: Use only Original Equipment Manufacturer (O.E.M.) replacement parts. Failure to do so could be hazardous, damage your snow thrower and void your warranty.

REPAIR PARTS

BAG OF PARTS

SNOW THROWER - MODEL NO. ST 330T (96191008601), PRODUCT NO. 961 91 00-86

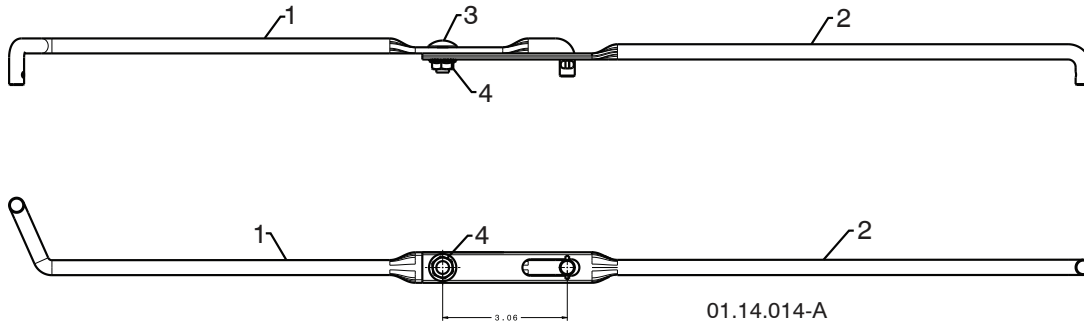

KEY NO.	PART NO.	DESCRIPTION
1	532 18 77-82	SHIFTER ROD TOP
2	532 18 77-84	SHIFTER ROD BOTTOM
3	872 27 05-05	CARRIAGE BOLT 5/16-18 X .75
4	532 15 53-77	NUT 5/16-18

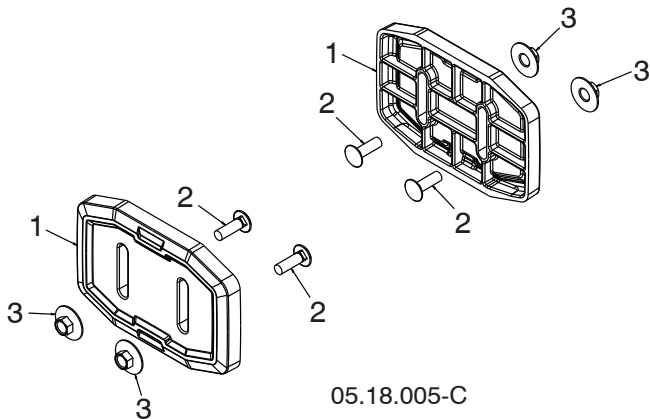

KEY NO.	PART NO.	DESCRIPTION
1	583 83 88-01	SKID PLATE UHMW
2	532 43 73-18	BOLT CARRIAGE 5/16-18 X 1.00 - BLK
3	585 80 28-01	NUT LRG FLANGE LOCK 5/16-18 - BLK

NOTE: All component dimensions given in U.S. inches. 1 inch = 25.4 mm
IMPORTANT: Use only Original Equipment Manufacturer (O.E.M.) replacement parts.
 Failure to do so could be hazardous, damage your snow thrower and void your warranty.

SNOW THROWER - MODEL NO. ST 330T (96191008601), PRODUCT NO. 961 91 00-86

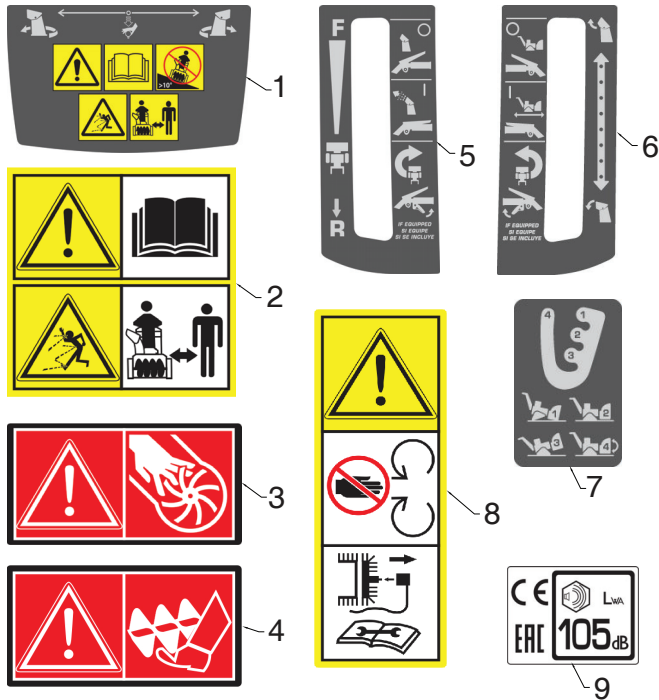

KEY NO.	PART NO.	DESCRIPTION
1	532 42 95-75	DECAL CONSOLE INSTRUCTION
2	532 18 40-45	DECAL AUGER
3	532 19 96-82	DECAL CHUTE
4	532 19 96-83	DECAL AUGER SAFETY
5	585 76 87-01	DECAL CONSOLE RH INSTRUCTION
6	585 76 87-03	DECAL CONSOLE LH INSTRUCTION
7	532 44 42-25	DECAL CONSOLE HEIGHT ADJUST
8	532 18 40-28	DECAL BELT GUARD
9	588 04 98-01	DECAL NOISE LEVEL

05.16.006-B

NOTE: All component dimensions given in U.S. inches. 1 inch = 25.4 mm
IMPORTANT: Use only Original Equipment Manufacturer (O.E.M.) replacement parts. Failure to do so could be hazardous, damage your snow thrower and void your warranty.

REPAIR PARTS

DECALS

SNOW THROWER - MODEL NO. ST 330T (96191008601), PRODUCT NO. 961 91 00-86

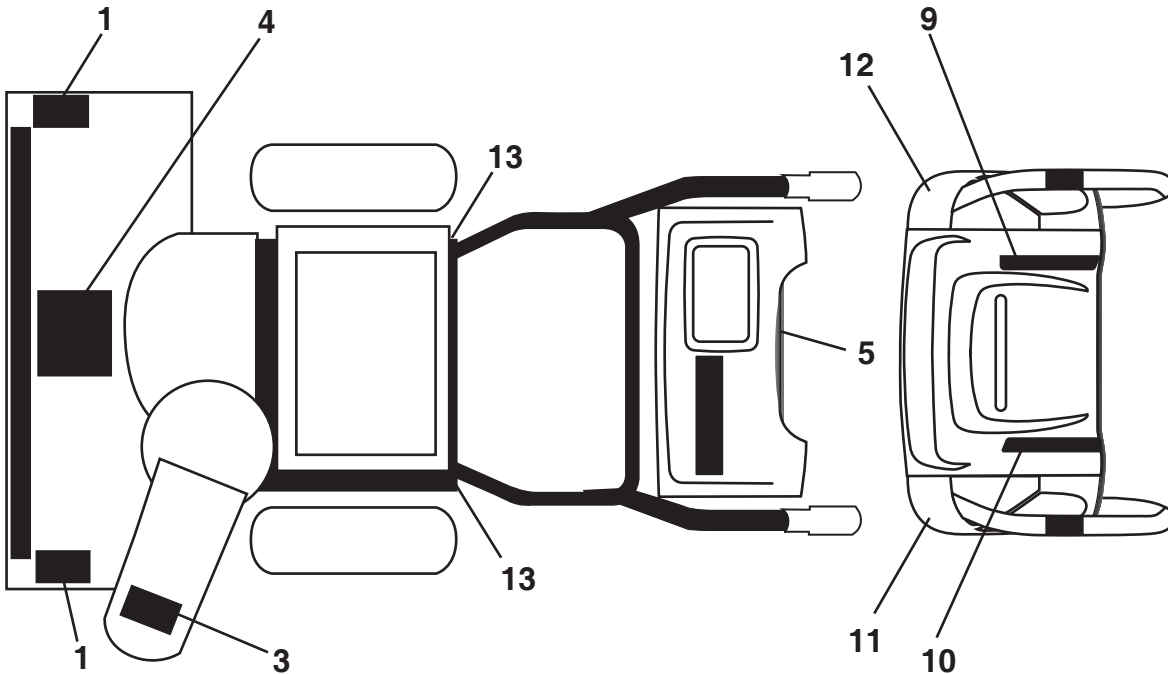

KEY NO.	PART NO.	DESCRIPTION
1	532 19 96-83	DECAL, DANGER
3	532 19 96-82	DECAL, DANGER, DEFLECTOR
4	532 18 40-45	DECAL, DANGER
5	588 04 98-01	DECAL
9	585 76 87-01	DECAL, CONS RT
10	585 76 87-03	DECAL, CONS LT
11	532 44 42-25	DECAL
12	532 44 47-68	DECAL
13	532 18 40-28	DECAL
--	115 68 57-20	OPERATOR'S MANUAL, EURO
--	115 68 57-10	OPERATOR'S MANUAL, SCAN
--	115 68 57-50	OPERATOR'S MANUAL, EBLOC
--	115 68 57-40	OPERATOR'S MANUAL, BALTIC

NOTE: All component dimensions given in U.S. inches. 1 inch = 25.4 mm
IMPORTANT: Use only Original Equipment Manufacturer (O.E.M.) replacement parts. Failure to do so could be hazardous, damage your snow thrower and void your warranty.

ENGINE, LCT

COMPLETE ENGINE-580426704

GEN II 291/306/369/414/420cc Snow Engines

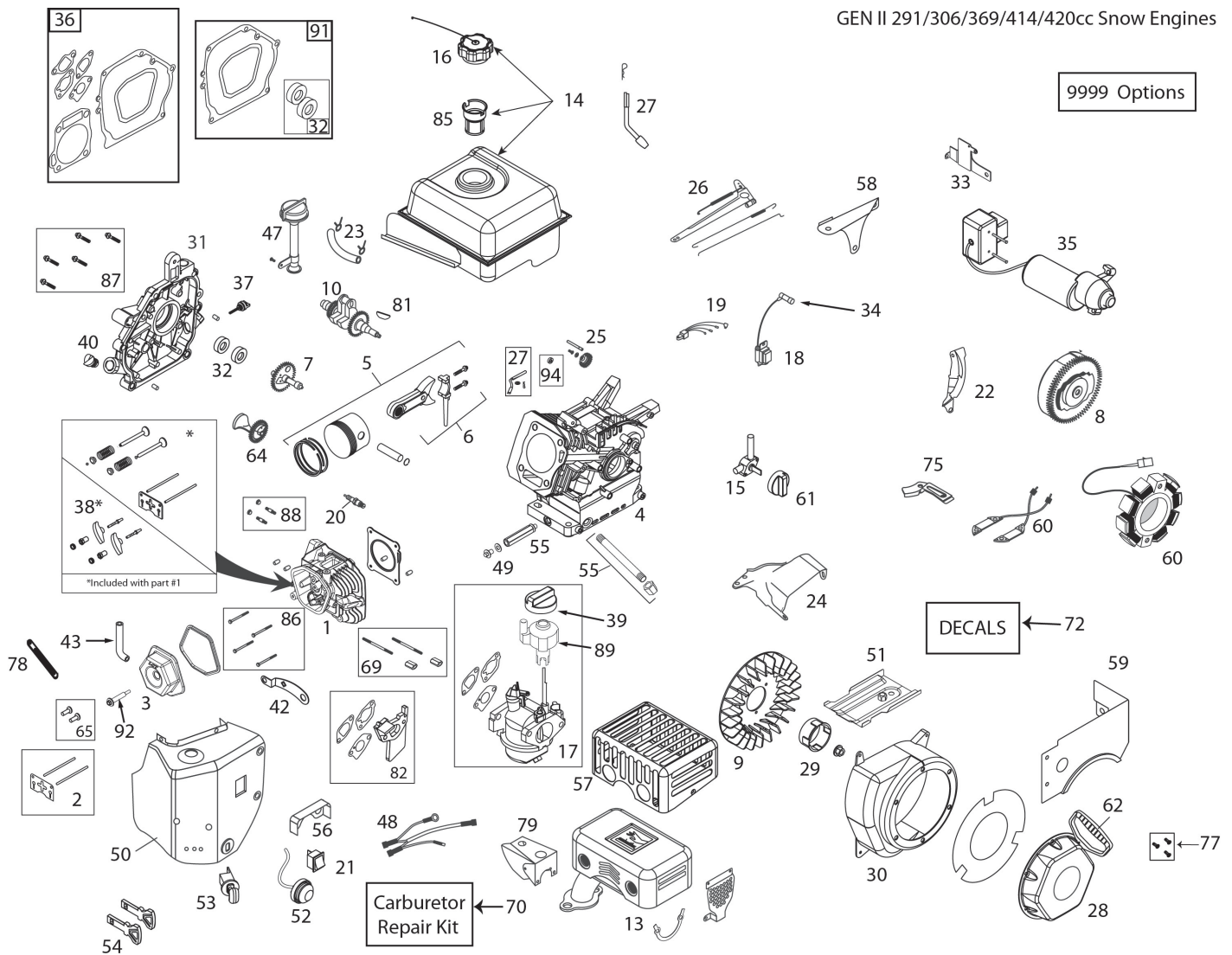

ILLUSTRATION FOR REFERENCE PURPOSES ONLY

KEY NO.	PART NO.	DESCRIPTION	KEY NO.	PART NO.	DESCRIPTION
1	532 42 96-05	CYLINDER HEAD ASSEMBLY (45 DEGREE 414CC NON-GENERATOR) (INCL. GASKET)	13	587 12 47-01	MUFFLER ASSEMBLY-SNOW
2	532 42 96-06	PUSH ROD & PLATE KIT (414CC)(INCL. VALVE COVER GSKT)	14	587 15 14-01	FUEL TANK ASSEMBLY-414CC SNOW (GLOSS BLACK)(ORDER DECAL KIT SEPARATE)
3	532 42 93-03	VALVE COVER (291/414CC) (INCL. GASKET)	15	532 42 92-34	FUEL TANK ON/OFF VALVE - GEN II SNOW
4	532 42 96-07	CYLINDER - 414CC - SNOW	16	532 42 92-11	FUEL TANK CAP - BLACK PLASTIC (VENTED) (SAME AS SKSN0301.1)
5	532 42 93-15	PISTON & ROD ASSEMBLY (414CC)	17	587 15 15-01	CARBURETOR (L12D) 414CC SNOW - W/IDLE-DOWN CONTROL - INCL GASKETS
6	587 15 12-01	CONNECTING ROD ASSEMBLY (414CC)	18	532 44 39-44	IGNITION COIL (CDI) (291-414CC)(STANDARD)
7	532 42 93-13	CAMSHAFT - MCR (414CC)	19	N/A	N/A
8	532 44 39-00	FLYWHEEL - ELECTRIC START (5-CHARGING MAGNETS) (414CC)	20	532 42 92-55	SPARK PLUG (SAME AS SK2083810.1)
9	532 42 93-06	COOLING FAN - FLYWHEEL (PLASTIC - 414CC)	21	532 42 92-23	ON/OFF SWITCH - ROCKER (SAME AS SKSN0403.1)
10	587 15 13-01	CRANKSHAFT #18 KEYED 414CC SNOW	22	532 42 92-32	WIRE GUARD PLATE
			23	532 43 21-46	FUEL HOSE KIT (229MM)

ENGINE, LCT**COMPLETE ENGINE-580426704**

KEY NO.	PART NO.	DESCRIPTION	KEY NO.	PART NO.	DESCRIPTION
24	532 42 92-86	SPEED CONTROL SHIELD-FIXED (414CC)	55	587 13 99-01	OIL DRAIN TUBE-SNOW (291/414CC)
25	532 42 93-12	GOVERNOR GEAR ASSEMBLY	56	532 42 92-13	CARBURETOR VAPOR SHIELD - 414CC SNOW
26	532 42 93-10	GOVERNOR ARM & LINK KIT (414CC)	57	532 43 74-66	CE COMPLLANT MUFFLER SHIELD (291/414CC)
27	532 42 93-11	GOVERNOR ARM PADDLE	58	532 42 92-98	SHIELD - GOVERNOR LINKAGE
28	587 15 16-01	RECOIL STARTER-414CC SNOW (GLOSS BLACK)(ORDER DECAL KIT SEPARATE)	59	587 15 19-01	FUEL TANK SKIRT-414CC SNOW (GLOSS BLACK)(ORDER DECAL KIT SEPARATE)
29	532 42 93-00	STARTER CUP - 414CC SNOW	60	532 44 38-96	CHARGING COIL (60-WATT AC) (291/414CC)
30	587 17 93-01	BLOWER HOUSING-414CC ES SNOWW/NOTCH (MATTE BLACK)(ORDER DECAL KIT SEPARATE)	61	532 43 27-52	FUEL CONTROL KNOB (GEN II SNOW - RED)
31	580 98 41-01	CRANKCASE COVER (HOFT & 2 LOW OIL FILLS)	62	532 44 38-99	STARTER GRIP-SNOW (DELUXE)
32	532 42 93-16	OIL SEAL KIT (414CC)	64	532 42 96-08	COUNTER WEIGHT KIT
33	532 42 92-90	ELECTRIC STARTER SWITCH BOX BRACKET - 291/414CC SNOW	65	581 37 29-01	TAPPET KIT (291/414CC) (SET OF 2)
34	532 43 69-66	SPARK PLUG BOOT - WITH METAL SHIELD (SNOW)	69	586 32 67-01	CARBURETOR MTG STUD KIT (2) (414CC)
35	532 43 74-65	230V EU ELECTRIC STARTER (414CC)	70	580 35 37-01	CARBURETOR REPAIR KIT (291/414CC)
36	532 42 96-09	ENGINE GASKET KIT (414CC)	72	532 43 56-48	HOP DECAL KIT (TWO STAGE)
37	532 43 55-34	SMALL BLACK OIL DIPSTICK (PLASTIC)	75	N/A	N/A
38	532 42 96-12	ROCKER ARM KIT (291/414CC) (INCL. GASKET)	77	532 43 26-88	RECOIL BOLT KIT (INCL. (3) MTG BOLTS)
39	532 42 92-24	CHOKE CONTROL KNOB (GEN II RED)	78	585 77 13-01	BREATHER TUBE RETAINING STRAP
40	532 42 92-42	NON-REMOVABLE PLASTIC PLUG (291/414CC)	79	587 15 20-01	SHIELD - CARBURETOR COVER - 414CC
42	532 42 92-57	CDI BOX BRACKET-SNOW	81	585 29 72-01	WOODRUFF FLYWHEEL KEYS (5-PACK) (5X6X18MM)
43	580 35 38-01	BREATHER TUBE (291/414CC)	82	585 02 05-01	CARBURETOR SPACER (414CC)
47	532 42 92-37	HIGH OIL-FILL TUBE & CAP (NO DIPSTICK)	85	586 32 56-01	FUEL TANK STRAINER
48	532 42 92-84	WIRE HARNESS (414CC SNOW)	86	586 32 74-01	CYLINDER HEAD BOLT KIT (4) (291-414CC)
49	532 43 54-94	OIL DRAIN PLUG W/WASHER (291/414CC)	87	586 32 70-01	CC COVER BOLT KIT (7) (414CC)
50	587 15 18-01	HEATER BOX ASSEMBLY- 414CC SNOW (GLOSS BLACK) (ORDER DECAL KIT SEPARATE)	88	586 32 68-01	MUFFLER MTG STUD KIT (2)
51	532 42 92-31	SHIELD - CYLLNDER (291/414CC SNOW)	89	587 12 48-01	SPEED CONTROL KNOB, GEN II, SNOW
52	532 42 92-18	PRIMER BULB WITH HOSE-SNOW (SAME AS SKSN0304.1)	91	587 99 41-04	CRANKSHAFT GASKET KIT 369-414CC
53	532 42 92-21	SAFETY KEY SWITCH W/KEYS (SAME AS SKSN0401.1)	92	587 99 52-01	VALVE COVER BOLT_WITH SEAL
54	532 44 30-59	KEY SET - RED (2) (SNOW)	94	588 48 55-01	GOV SHAFT OIL SEAL
			9999	586 32 65-01	HIGH ALTITUDE JET (>5,000 FEET)(414CC L12 CARBURETOR)

