

ILLUSTRATED PARTS LIST

MODEL NO. 96041036901

CUSTOMER CATALOG NO. TS 238

PRODUCT NO. 960 41 03-69

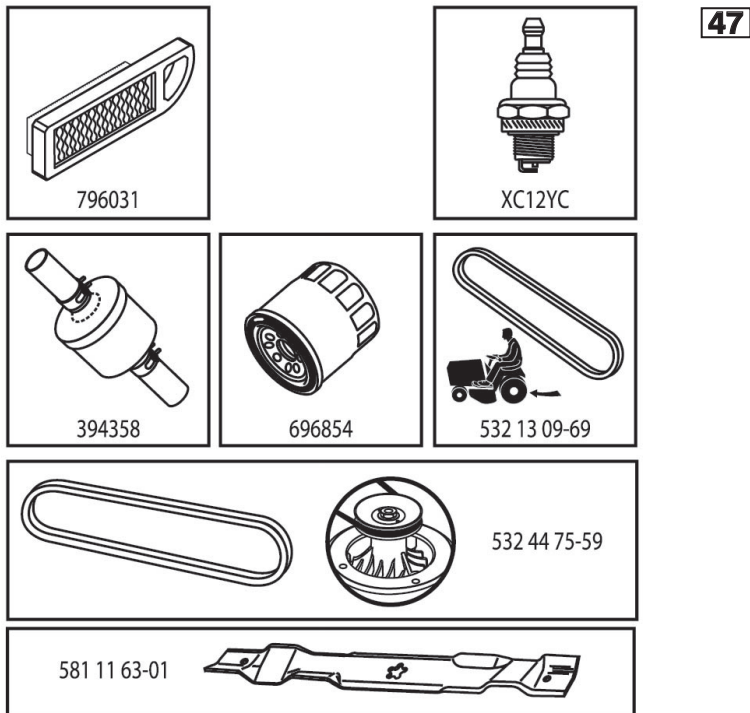

587456401

**TRACTOR - - MODEL NO. TS 238 (96041036901), PRODUCT NO. 960 41 03-69
DECALS 27**

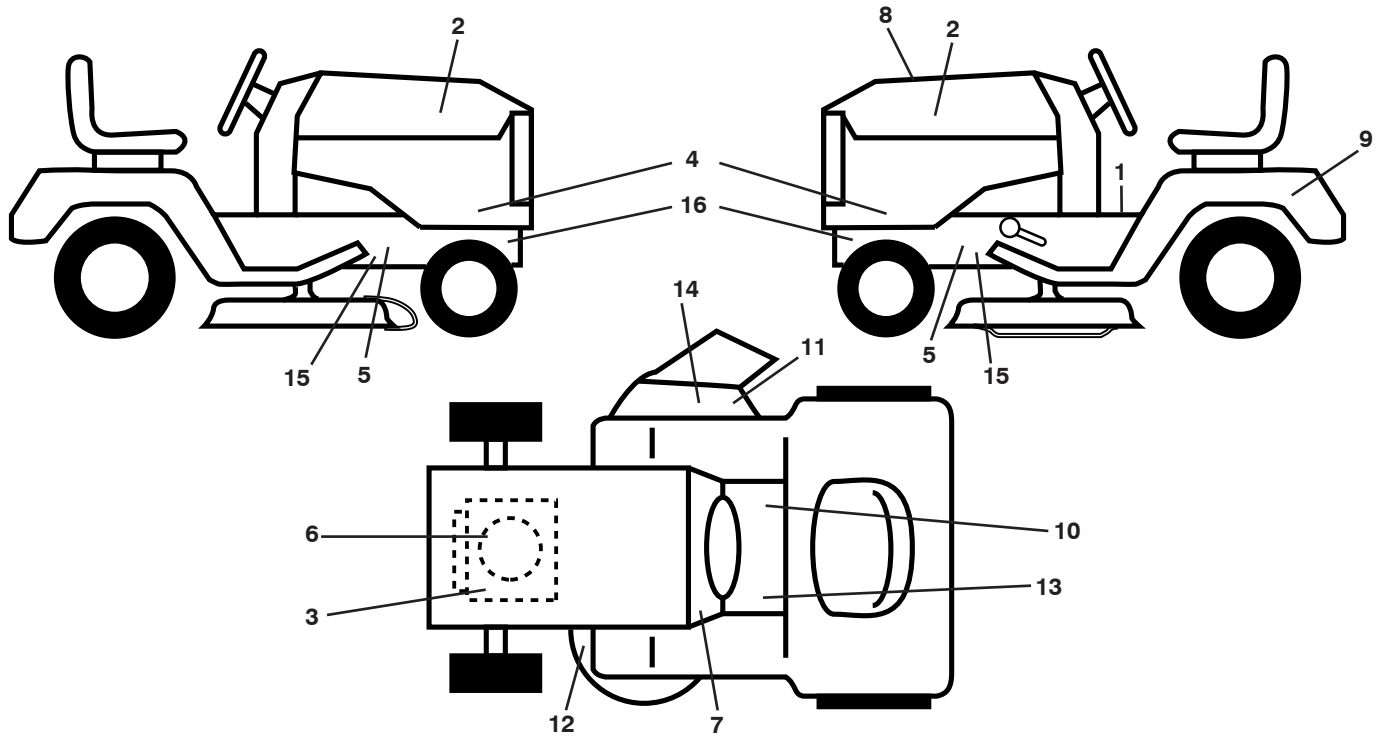

KEY NO.	PART NO.	DESCRIPTION
1	581 57 81-01	Decal, Operators
2	581 62 73-01	Decal, Badge
3	581 57 97-01	Decal, Warning Eng. Warn.
4	587 55 17-01	Decal, Panel Side
5	581 57 96-01	Decal, Chassis Hot Muffler
6	587 38 52-01	Decal, Engine
7	586 06 62-01	Decal, Snowflake
8	587 45 64-01	Decal, Rpl
9	532 14 50-05	Decal, Battery Dnge/Poi
10	581 57 80-01	Decal, Saddle Brake Parking
11	581 57 92-01	Decal, Warning
12	581 58 00-03	Decal, Mower V-Belt Schematic
13	581 72 40-01	Decal, Brake/Clutch Symbol

KEY NO.	PART NO.	DESCRIPTION
14	584 90 46-01	Decal, Deflect. Warning
15	581 57 98-01	Decal, Warning Service/Fire
16	581 57 98-01	Decal, Warning
--	581 72 48-01	Decal, Bypass
--	581 72 46-01	Decal, Drawbar Load Limit
--	532 43 96-81	Pad, Footrest, LH
--	532 43 96-82	Pad, Footrest, RH
--	588 89 98-20	Manual Oper. Euro
--	588 89 98-50	Manual Oper. Scan
--	588 89 98-10	Manual Oper. E-Bloc
--	588 89 98-40	Manual Oper. Baltic
--	589 24 27-79	Manual Oper. Japanese

WHEELS AND TIRES

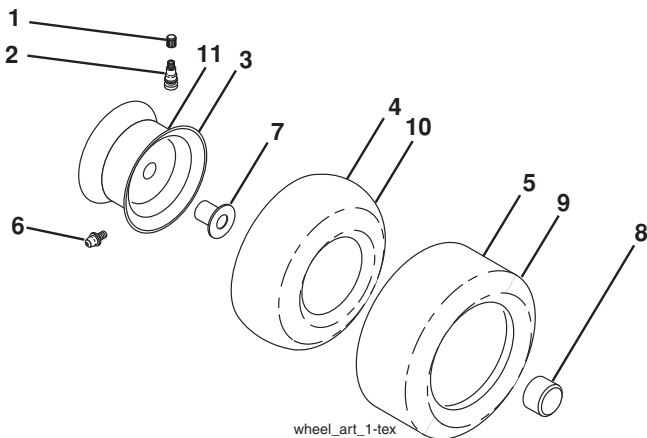

KEY NO.	PART NO.	DESCRIPTION
1	532 05 91-92	Cap Valve Tire
2	532 06 51-39	Stem Valve
3	532 13 83-36	Rim Asm Front
4	532 05 99-04	Tube Front (Service Item Only)
5	532 10 62-22	Tire Front 15 x 6-6
6	532 12 49-57	Fitting Grease (Front Wheel Only)
7	532 12 49-59	Bearing Flange (Front Wheel Only)
8	532 17 50-39	Cap Axle Blk 1 50 x 1 00
9	532 13 84-68	Tire Rear 20 x 8-8
10	532 12 49-26	Tube Rear (Service Item Only)
11	532 13 83-37	Rim Asm Rear
--	532 14 43-34	Sealant, Tire (10 oz. Tube)

NOTE: All component dimensions given in U.S. inches
1 inch = 25.4 mm

TRACTOR - - MODEL NO. TS 238 (96041036901), PRODUCT NO. 960 41 03-69 SCHEMATIC 38

SCH12

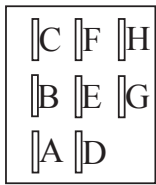
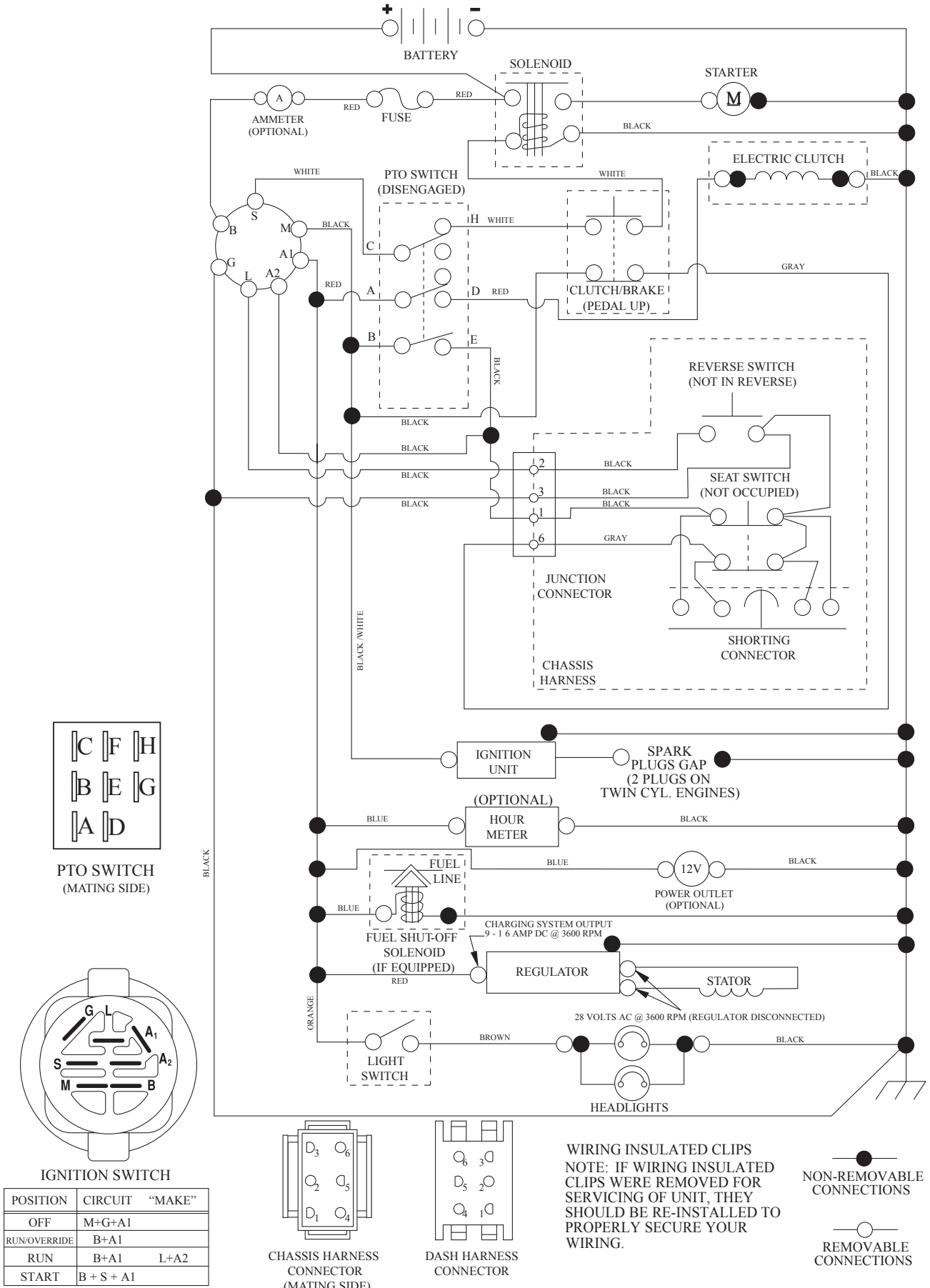

PTO SWITCH (MATING SIDE)

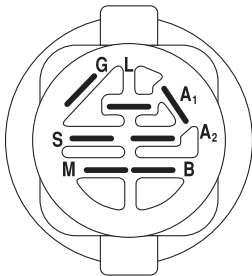

IGNITION SWITCH

POSITION	CIRCUIT "MAKE"
OFF	M+G+A1
RUN/OVERRIDE	B+A1
RUN	B+A1 L+A2
START	B + S + A1

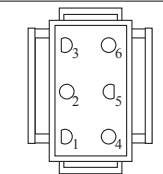

CHASSIS HARNESS CONNECTOR (MATING SIDE)

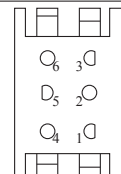

DASH HARNESS CONNECTOR

TRACTOR - - MODEL NO. TS 238 (96041036901), PRODUCT NO. 960 41 03-69
ELECTRICAL 32

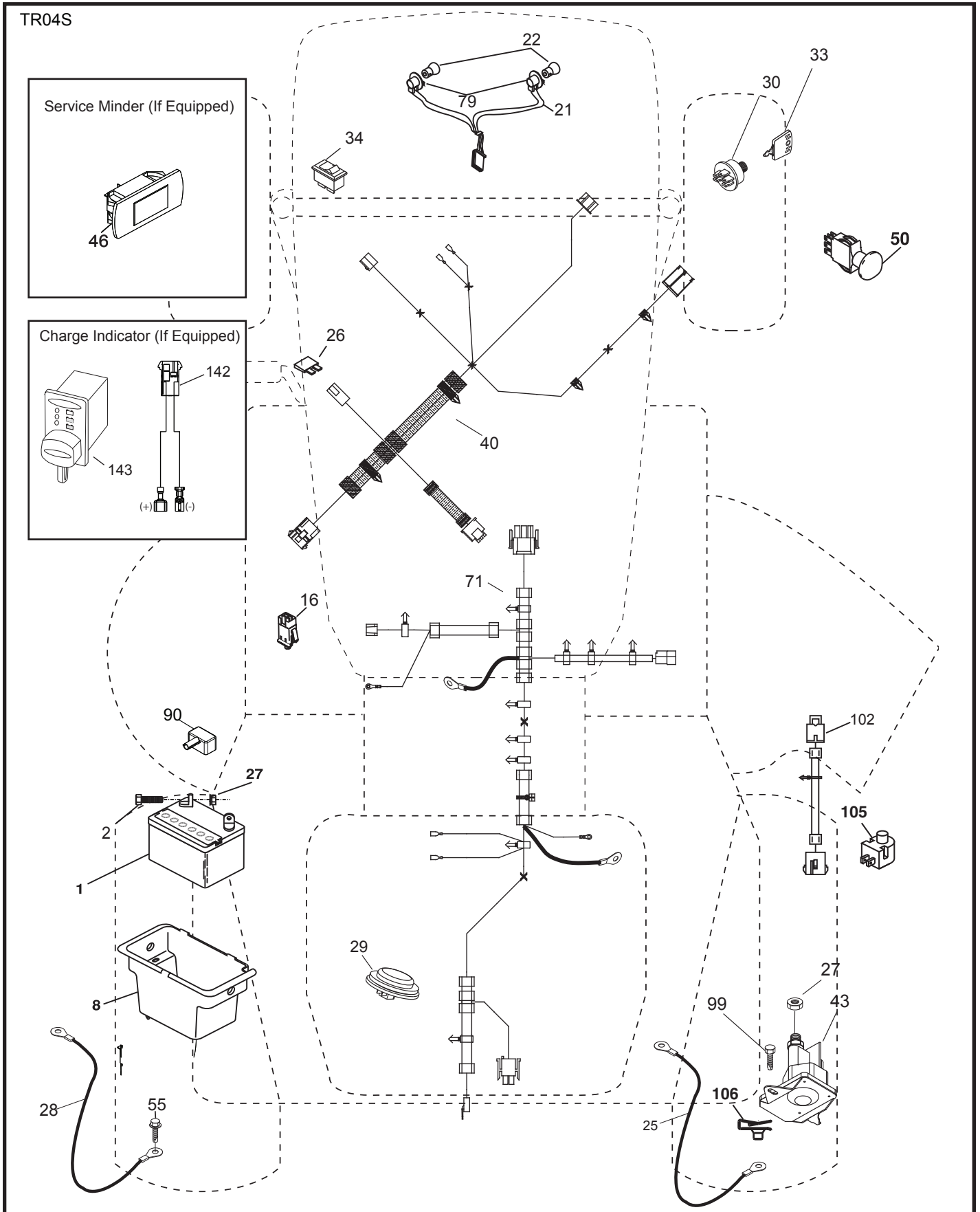

**TRACTOR - - MODEL NO. TS 238 (96041036901), PRODUCT NO. 960 41 03-69
ELECTRICAL 32**

KEY NO.	PART NO.	DESCRIPTION
1	532 16 34-65	Battery
2	874 76 04-12	Bolt Hex Head 1/4-20 x 3/4
8	532 19 32-28	Box Battery
16	532 17 61-38	Switch Interlock Push-In
21	532 40 02-52	Harness Socket Light W/4152J
22	532 00 41-52	Bulb Light
25	581 49 80-01	Cable Starter
26	532 17 51-58	Fuse
27	873 51 04-00	Nut Keps Hex 1/4-20 unc
28	532 42 16-86	Cable, Ground
29	532 40 15-45	Switch, Seat
30	532 19 33-50	Switch, Ign
33	532 41 19-35	Key/Chain
34	532 11 07-12	Switch Light / Reset
40	585 55 53-01	Harness Ign. Dash
43	532 19 25-07	Solenoid
46	586 16 18-01	Gauge Hourmeter
50	532 17 46-51	Switch PTO
55	817 06 05-12	Screw Thdrol 5/16-18 x 3/4 TYTT
71	501 13 37-01	Harness Ign. Chassis
79	532 17 52-42	Socket Asm
90	532 43 53-95	Cover Terminal
99	817 67 04-12	Screw 1/4-20 x 3/4
102	532 40 44-54	Harness Pigtail Tex ROS Tufftorq
105	532 40 75-68	Switch Reverse
106	532 17 48-14	Palnut 1/4 Lugs
142	583 85 78-01	Charge Port Pigtail
143	532 44 80-59	Charge Port

NOTE: All component dimensions given in U.S. inches
1 inch = 25.4 mm

TRACTOR - - MODEL NO. TS 238 (96041036901), PRODUCT NO. 960 41 03-69
CHASSIS AND ENCLOSURES 39

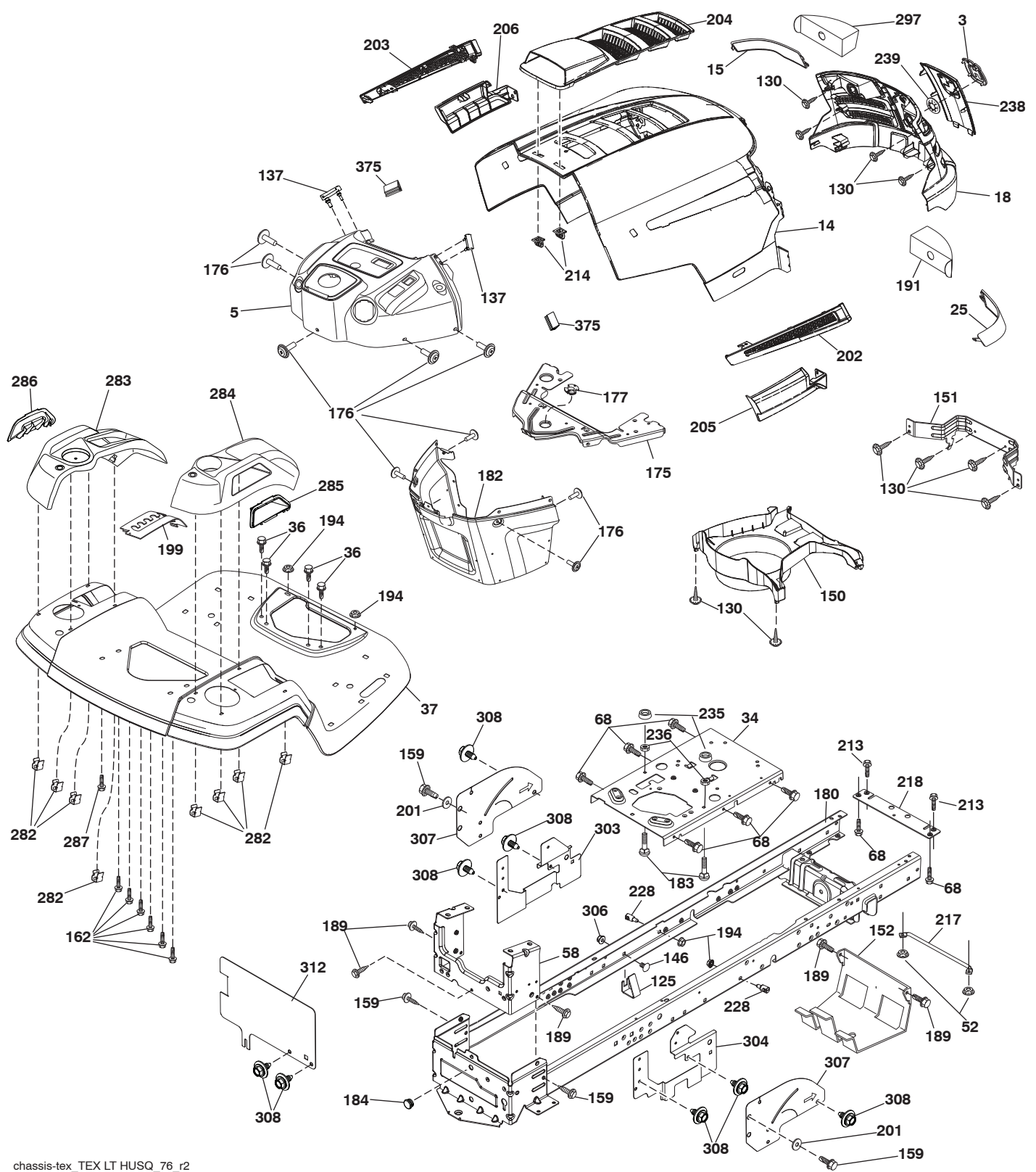

chassis-tex_TEX LT HUSQ_76_r2

**TRACTOR - - MODEL NO. TS 238 (96041036901), PRODUCT NO. 960 41 03-69
CHASSIS AND ENCLOSURES 39**

KEY NO.	PART NO.	DESCRIPTION	KEY NO.	PART NO.	DESCRIPTION
3	581 05 63-01	Logo	202	532 44 13-42	Vent Side Hood RH
5	585 52 98-07	Dash	203	532 44 13-43	Vent Side Hood LH
14	532 44 12-67	Hood	204	532 44 13-75	Vent Top Hood
15	532 44 14-28	Lens LH	205	532 44 13-44	Skirt Side RH
18	532 44 13-68	Grille	206	532 44 13-45	Skirt Side LH
25	532 44 14-27	Lens RH	213	874 76 05-12	Bolt 5/16-18 x 3/4
34	580 91 08-01	Plate Engine	214	532 19 91-45	Clip Retainer
36	817 06 05-12	Screw 5/16-18 x 3/4	217	532 40 91-67	Rod Pivot Hood
37	532 44 12-66	Fender	218	532 19 63-95	X-Piece Hood Stop
52	873 68 05-00	Nut Crown Lock 5/16	228	532 19 51-61	Stud Fastener
58	532 41 22-80	Drawbar	235	532 40 61-29	Spacer Fender
68	817 49 05-08	Screw THDROL 5/16-18 x 1/2	236	873 93 05-00	Nut Lock 5/16-18 unc
125	581 68 48-01	Clip Fuel Line	238	532 44 13-74	Trim
130	532 41 63-58	Screw #10 x 0.75 BOS Thread	239	532 40 48-83	Clip Tinnerman
137	532 40 75-90	Bumper Dash	282	532 41 41-10	Clip Retainer Console
146	581 85 79-01	Bolt	283	532 44 20-39	Console Deck Lift Husq N/FR GR
150	532 40 66-62	Air Duct	284	532 43 98-23	Console SHFT HYD HUSQ LT
151	532 40 78-07	Bracket Pivot	285	532 41 63-15	Console INSRT RH HUSQ
152	532 19 95-35	Shield Browning	286	532 41 63-17	Console INSRT LH HUSQ
159	817 00 06-12	Screw Hexwsh Thrd 3/8-16 x 3/4	287	817 60 04-06	Screw Hex WASHEAD 1/4-20 x 3/8
162	532 14 24-32	Screw	297	532 40 66-65	Insert Reflective LH
175	532 19 94-72	Crossmember	303	587 49 34-02	Shield Lower LH
176	532 40 07-76	Screw 10-24 x 5/8	304	587 86 51-02	Shield Lower RH
177	532 19 52-28	Bushing Steering	306	873 90 06-00	Nut Lock Flg. 3/8-16 unc
180	532 41 50-64	Chassis	307	587 49 46-01	Shield Upper
182	532 40 71-76	Dash Lower	308	532 17 18-77	Bolt 5/16-18 unc x 3/4 w/SEMS
183	874 52 05-20	Bolt 5/16-18 x 1-1/4 Full Thd.	312	587 49 30-02	Shield Drawbar French
184	587 55 41-01	Plug	375	586 90 82-01	Dash Clip-On Bumper
189	817 00 05-12	Screw 5/16-18 x 3/4	--	532 40 09-44	Bumper
191	532 41 65-01	Insert Reflective RH			
194	873 90 05-00	Nut Lock Hex Flange 5/16-18			
199	532 41 34-85	Plate Deck Lift Husqvarna LT			
201	819 13 20-16	Washer 13/32 x 1-1/4 x 16 Ga.			

NOTE: All component dimensions given in U.S. inches
1 inch = 25.4 mm

**TRACTOR - - MODEL NO. TS 238 (96041036901), PRODUCT NO. 960 41 03-69
DRIVE **40****

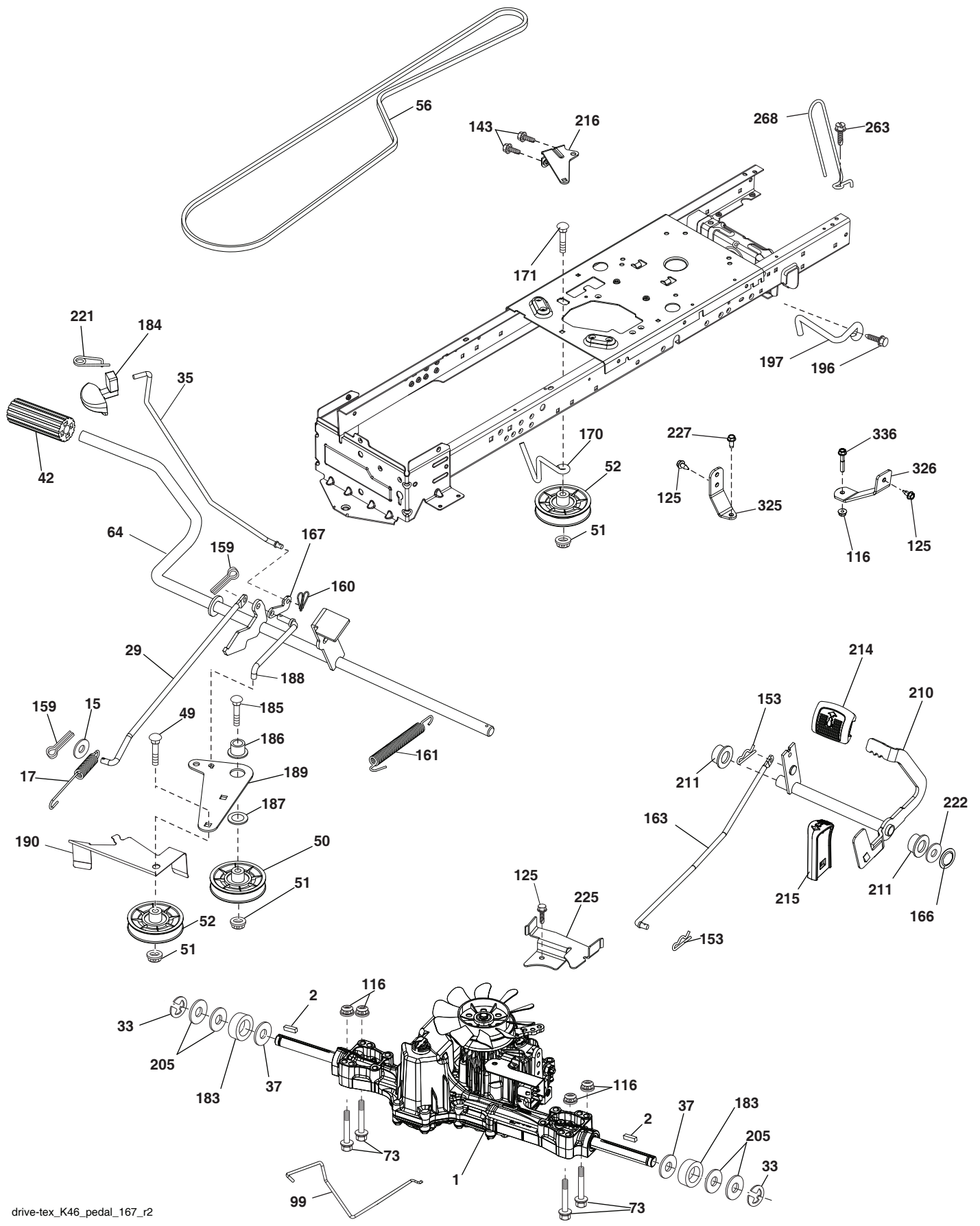

drive-tex_K46_pedal_167_r2

**TRACTOR - - MODEL NO. TS 238 (96041036901), PRODUCT NO. 960 41 03-69
DRIVE **40****

KEY NO.	PART NO.	DESCRIPTION	KEY NO.	PART NO.	DESCRIPTION
1	---	Transaxle, Tuff Torq K46BT (426120)(Order parts from transaxle manufacturer.)	171	872 11 06-16	Bolt 3/8-16 x 2
2	532 12 35-83	Key	183	532 13 70-57	Spacer Axle
15	819 13 13-16	Washer 13/32 x 13/16 x 16 Ga.	184	532 41 14-84	Handle Parking Brake
17	532 41 36-78	Spring, Brake	185	872 11 06-22	Bolt RDHD SQNK 3/8-16 unc x 2
29	532 40 38-06	Rod, Brake	186	532 19 43-21	Spacer Retainer
33	812 00 00-01	Ring E	187	819 13 32-10	Washer
35	532 40 10-31	Rod, Brake, Park	188	582 21 70-01	Link Clutch Ground Drive, Long
37	532 18 89-67	Washer Harden	189	532 19 43-17	Bellcrank Ground Drive
42	532 12 48-72	Cover, Foot Pedal	190	532 19 43-18	Keeper Bellcrank Ground Drive
49	872 11 06-14	Bolt	196	817 00 06-16	Screw 3/8-16 x 1 SMGML
50	532 19 43-27	Pulley Idler Flat	197	585 65 86-01	Link Clutch Anti-Rotation
51	873 90 06-00	Lock Nut 3/8-16	205	532 12 17-48	Washer
52	532 19 43-26	Idler V-Groove	210	532 40 09-80	Rocker Asm Pedal Control
56	532 13 09-69	V-Belt, Drive	211	532 12 01-83	Bushing Shaft
64	532 19 78-65	Shaft Asm. Pedal Brake Control	214	532 42 12-63	Pedal Forward Pad Tex
73	874 49 05-40	Bolt Hx Flghd 5/16-18 x 2 1/2 G5	215	586 60 65-02	Pedal Reverse
99	532 41 57-42	Rod Bypass	216	532 19 61-31	Bracket Pulley Idler
116	873 90 05-00	Nut Lock Hex Flange 5/16-18	221	532 40 31-87	Retainer Spring Clip Handle
125	817 00 05-12	Screw 5/16-18 x 3/4	222	879 21 20-10	Washer 21/32 x 1-1/4
143	817 49 05-08	Screw Thdrol 5/16-18 x 1/2	225	532 40 33-19	Keeper Belt Transaxle
153	532 12 47-88	Retainer Spring	227	817 49 05-12	Screw Thdrol 5/16-18 X 3/4
159	876 02 04-12	Pin Cotter 1/8 x 3/4	263	817 00 06-12	Screw 3/8-16 x 3/4
160	532 16 94-84	Retainer Clip	268	532 18 24-02	Guard Muffler
161	532 10 57-09	Spring, Return, Clutch	325	585 66 85-02	Bracket Torque Strap LH
163	532 44 82-75	Rod Control Pedal K46	326	585 67 08-02	Bracket Torque Strap RH
166	532 42 91-64	Nut Push	336	587 25 96-01	Bolt 5/16-18 x 1-3/4 Flanged Hex
167	532 40 52-57	Latch Brake Parking			
170	532 19 43-22	Keeper Belt Centerspan			

NOTE: All component dimensions given in U.S. inches
1 inch = 25.4 mm

**TRACTOR - - MODEL NO. TS 238 (96041036901), PRODUCT NO. 960 41 03-69
ENGINE 24**

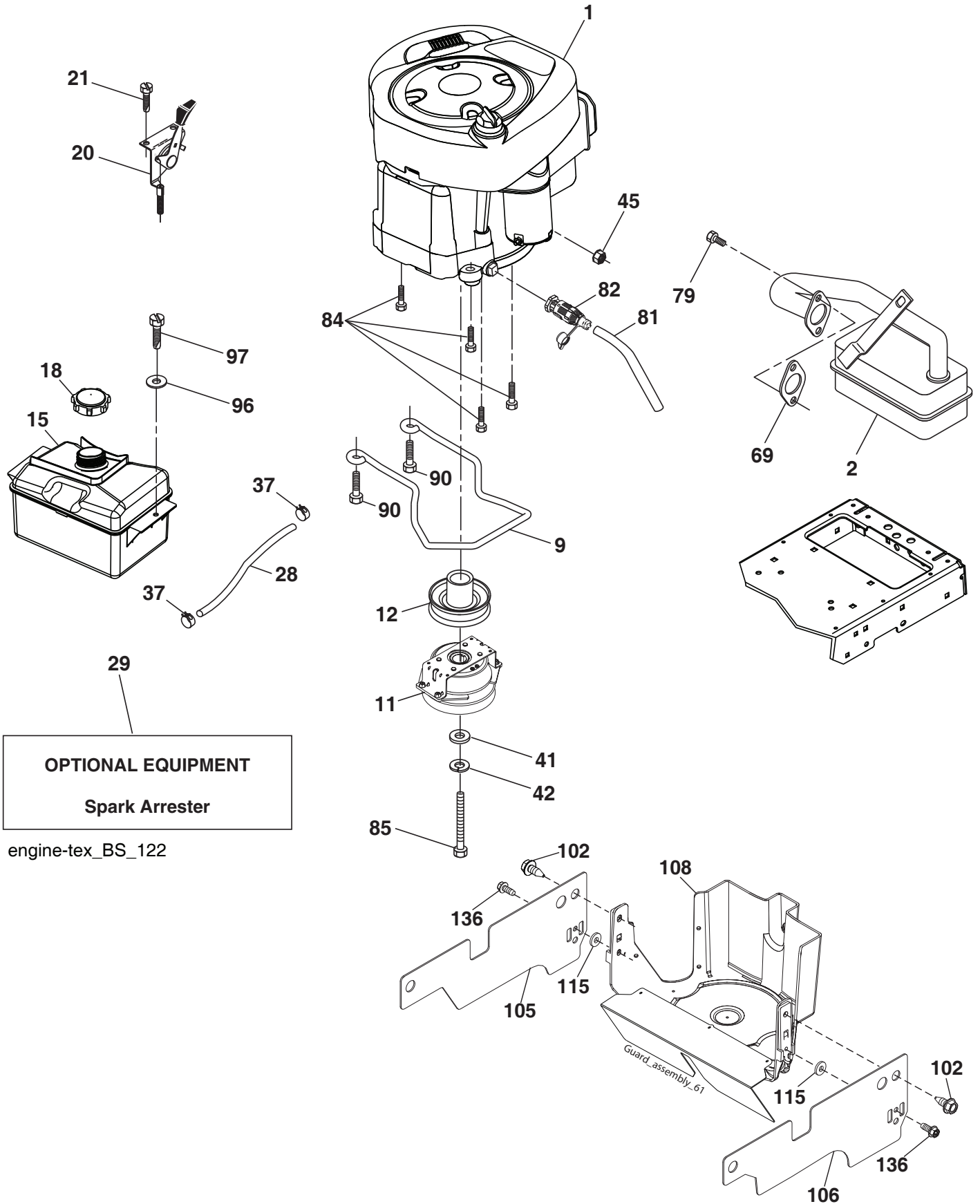

engine-tex_BS_122

**TRACTOR - - MODEL NO. TS 238 (96041036901), PRODUCT NO. 960 41 03-69
ENGINE 24**

KEY NO.	PART NO.	DESCRIPTION
1	---	Engine Briggs Model No. 31S777-0003-B1 (587451501) (Order parts from engine manufacturer.)
2	532 13 73-52	Muffler
9	501 83 26-01	Keeper Belt Engine
11	587 24 15-01	Clutch Electric
12	532 40 50-97	Pulley Engine
15	581 28 99-01	Tank Fuel
18	532 43 02-20	Cap Asm Fuel
20	532 18 38-97	Control Throttle
21	532 41 63-58	Screw 10 x 0.750
28	532 13 70-40	Fuel Line
29	532 13 71-80	Spark Arrester Kit
37	532 12 34-87	Clamp Hose
41	532 12 61-97	Washer 1-1/2 OD x 15/32
42	810 04 07-00	Bolt 5/16-18 unc x 3/4 w/Sems
45	873 51 04-00	Nut Keps Hex 1/4-20 unc
69	532 16 52-91	Gasket
79	532 19 23-34	Screw 5/16-18 x .75
81	532 14 84-56	Tube Oil Drain
82	532 42 82-87	Valve Oil Drain
84	817 06 06-20	Screw 3/8-16 x 1-1/4
85	581 33 28-04	Bolt 7/16-20 x 3.5 Gr. 5
90	817 00 06-16	Screw 3/8-16 x 1
96	819 09 14-16	Washer 9/32 x 7/8 x 16 Ga.
97	817 67 04-12	Screw 1/4-20 x 3/4
102	817 00 05-12	Screw
105	501 26 72-02	Shield Side LH
106	501 26 82-02	Shield Side RH
108	587 17 95-01	Cover Eng. Pulley w/SHLD 38", 42"
115	532 43 17-61	Palnut #10
136	532 42 17-56	Screw, #10 0.500, BOS

NOTE: All component dimensions given in U.S. inches
1 inch = 25.4 mm

Engine Power Rating Information

The gross power rating for individual gas engine models is labeled in accordance with SAE (Society of Automotive Engineers) code J1940 (Small Engine Power & Torque Rating Procedure), and rating performance has been obtained and corrected in accordance with SAE J1995 (Revision 2002-05). Torque values are derived at 3060 RPM; horsepower values are derived at 3600 RPM. Actual gross engine power will be lower and is affected by, among other things, ambient operating conditions and engine-to-engine variability. Given both the wide array of products on which engines are placed and the variety of environmental issues applicable to operating the equipment, the gas engine will not develop the rated gross power when used in a given piece of power equipment (actual "on-site" or net power). This difference is due to a variety of factors including, but not limited to, accessories (air cleaner, exhaust, charging, cooling, carburetor, fuel pump, etc.), application limitations, ambient operating conditions (temperature, humidity, altitude), and engine-to-engine variability. Due to manufacturing and capacity limitations, Briggs & Stratton may substitute an engine of higher rated power for this Series engine.

TRACTOR - - MODEL NO. TS 238 (96041036901), PRODUCT NO. 960 41 03-69
STEERING ASSEMBLY **41**

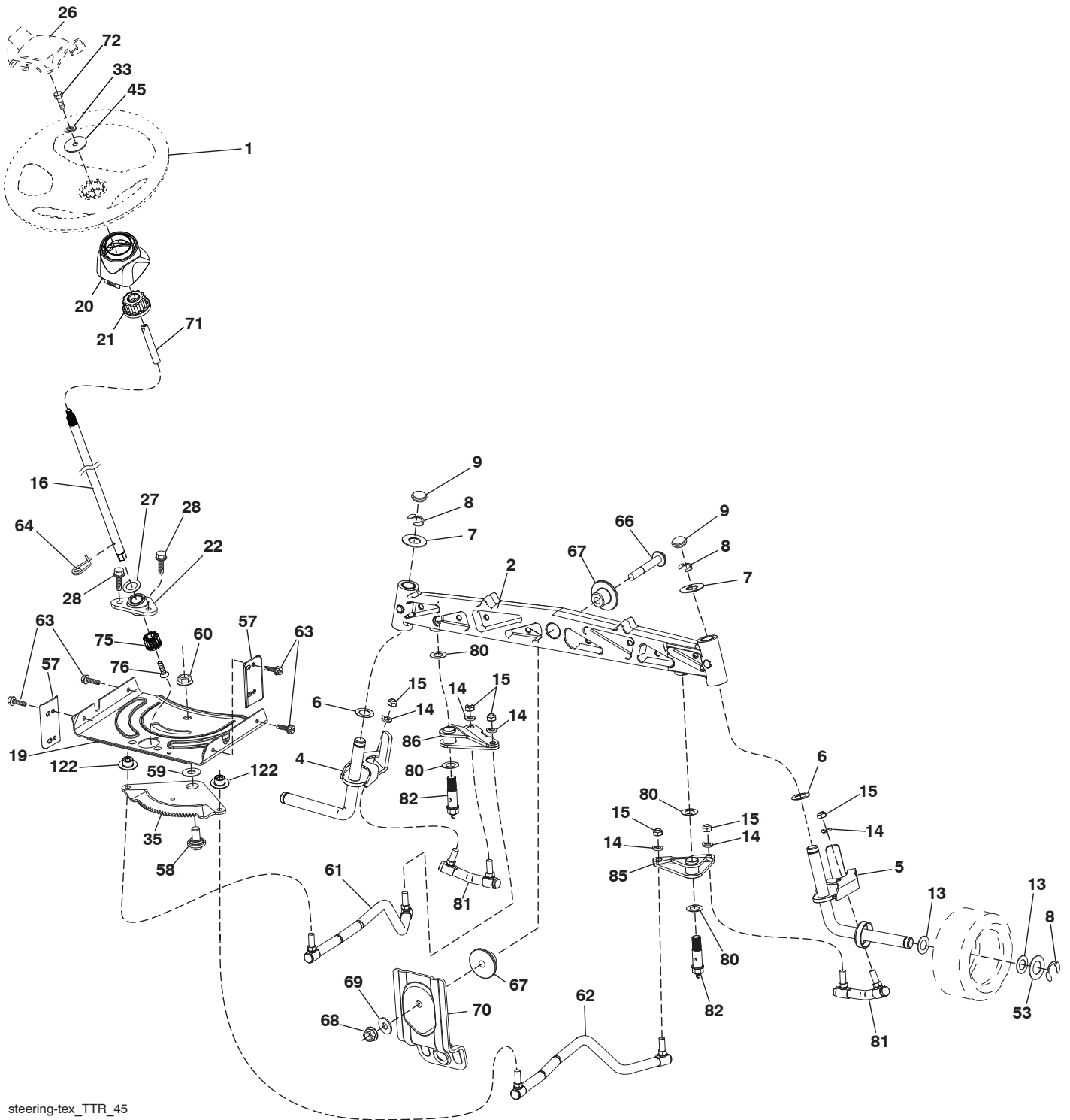

steering-tex_TTR_45

TRACTOR - - MODEL NO. TS 238 (96041036901), PRODUCT NO. 960 41 03-69
STEERING ASSEMBLY 41

KEY NO.	PART NO.	DESCRIPTION
1	532 43 97-40	Wheel, Steering
2	532 43 68-70	Axle Asm., Front
4	532 43 68-73	Spindle Asm., LH
5	532 43 68-74	Spindle Asm., RH
6	532 12 49-31	Washer Thrust 0.75 x 1.23
7	532 12 17-48	Washer 25/32 x 1-5/8 x 16 Ga.
8	812 00 00-29	Ring, Klip #T5304-75
9	532 12 12-32	Cap, Spindle
13	532 12 17-49	Washer 25/32 x 1-1/4 x 16 Ga.
14	810 04 06-00	Washer, Lock 3/8
15	873 54 06-00	Nut, Crown Lock 3/8-24 unf
16	585 86 92-02	Shaft Steering
19	532 19 47-29	Plate Steering
20	532 44 14-25	Boot, Steering
21	532 43 77-47	Adapter, Wheel Steering
22	585 02 99-01	Bearing, Asm.
26	532 43 97-43	Insert, Wheel Steering
27	819 21 16-16	Washer 21 x 32 x 1 x 16 Ga.
28	817 00 06-12	Screw 3/8-16 x 3/4
33	810 04 05-00	Washer 5/16
35	532 44 07-70	Gear, Sector Plate
45	819 11 38-12	Washer 11/32 ID x 2-3/8 OD x 12 Ga.
53	532 18 89-67	Washer Hardened .793 x 1.637 x .060
57	532 40 74-65	Bracket Upstop
58	532 19 47-47	Bolt Shoulder Sector Pivot CFM
59	532 19 47-48	Washer Thrust Sector Steering
60	873 97 10-00	Nut Flange Lock 5/8-11
61	581 92 62-02	Draglink, LH
62	581 92 63-02	Draglink, RH
63	817 00 05-12	Screw 5/16-18 x 3/4
64	532 19 98-49	Retainer Clip Spring Steering
66	871 02 07-48	Bolt Hex Fghd 7/16-14 x 3 Serr
67	532 19 47-37	Bushing PM Front Axle
68	873 90 07-00	Nut Lock Flange 7/16-14 Gr. 5
69	532 19 91-62	Washer 1.5 x .505 x .118
70	585 33 88-01	Bracket Deck Susp. Front
71	532 19 07-52	Shaft Extension
72	532 42 89-82	Bolt 5/16-18 x 4
75	580 68 37-01	Pinion
76	580 68 36-01	Screw
80	532 00 13-70	Washer Thrust 5/8 x 1.10 x 1/32
81	532 43 68-87	Subasm. Link Cross RH
82	532 44 21-47	Subasm. Pivot Bolt
85	532 44 18-73	Subasm. Pivot RH
86	532 44 18-72	Subasm. Pivot LH
122	532 44 49-62	Cap Gear

NOTE: All component dimensions given in U.S. inches
1 inch = 25.4 mm

TRACTOR - - MODEL NO. TS 238 (96041036901), PRODUCT NO. 960 41 03-69
MOWER DECK 44

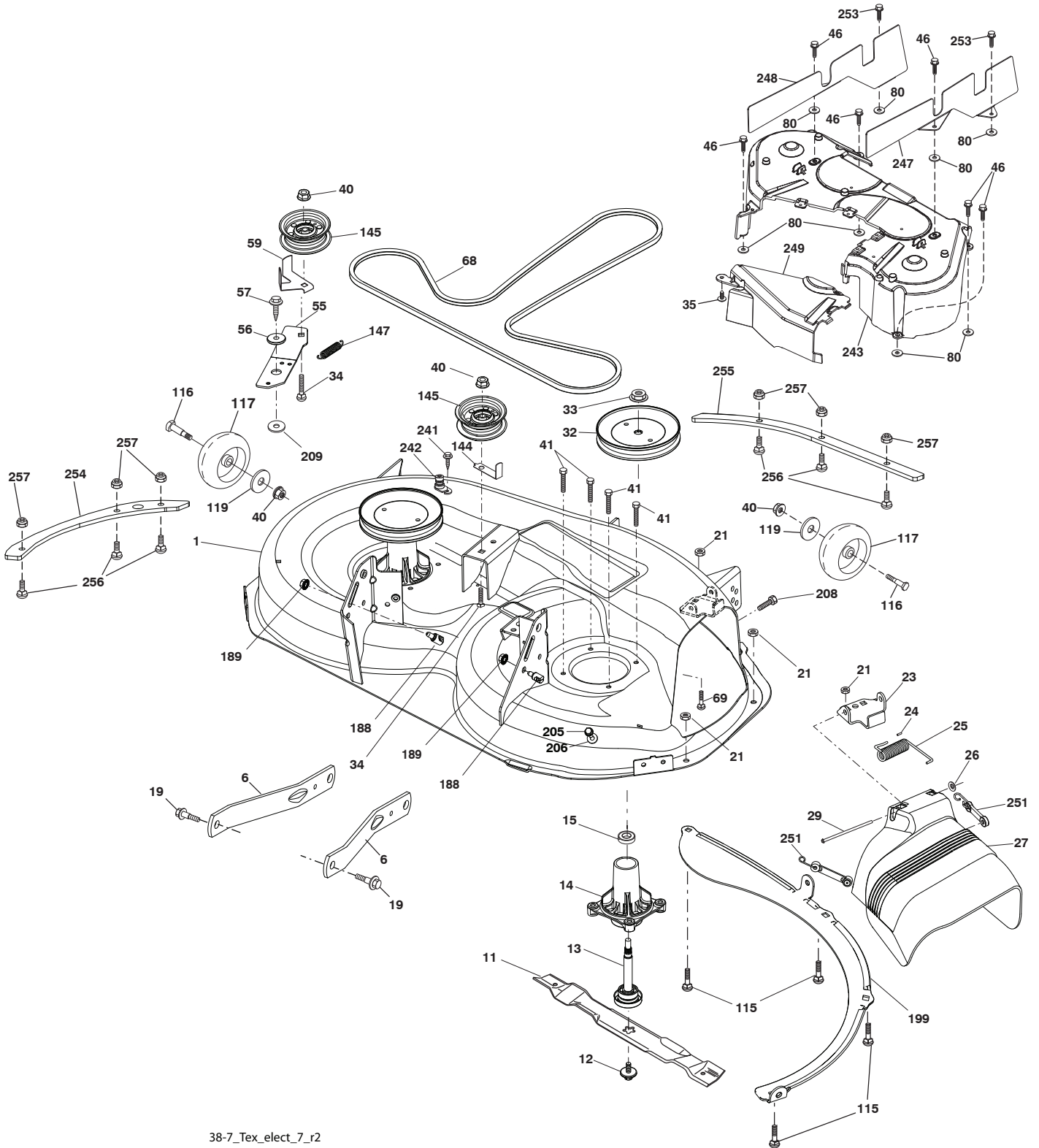

38-7_Tex_elect_7_r2

**TRACTOR - - MODEL NO. TS 238 (96041036901), PRODUCT NO. 960 41 03-69
MOWER DECK 44**

KEY NO.	PART NO.	DESCRIPTION	KEY NO.	PART NO.	DESCRIPTION
1	587 77 18-08	Mower Housing	145	532 19 31-97	Pulley Idler
6	532 19 51-86	Arm Suspension	147	532 19 72-51	Spring Return
11	581 11 63-01	Blade	188	532 19 51-61	Stud Fastener
12	532 19 30-03	Screw 7/16-20 x 1 Hx	189	873 90 05-00	Nut Lock Hex Flange
13	532 19 28-72	Shaft Assembly, Mandrel	199	532 40 00-95	Baffle Vortex
14	532 18 72-81	Housing, Mandrel	205	817 49 04-16	Screw 1/4 - 20 x 1.00 77
15	532 11 04-85	Bearing, Ball, Mandrel	206	819 09 14-16	Washer 9/32 x 7/8 x 16 Ga.
19	532 19 65-39	Bolt, Shoulder	208	817 67 06-08	Screw 3/8 - 16 x 1/2
21	873 68 05-00	Nut, Crownlock 5/16-18 unc	209	819 13 32-10	Washer 13/32 x 2 x 10
23	532 19 25-57	Bracket, Deflector	241	532 15 29-27	Screw TT. #10-32. 5. 3/8
24	532 10 53-04	Cap, Sleeve	242	532 41 55-98	Port Washout
25	532 19 70-26	Spring, Torsion, Deflector	243	532 40 65-10	Cover Deck 38-7 Assy.
26	532 11 04-52	Nut, Push	247	532 43 23-61	Shield Deck RH Assy.
27	532 40 16-18	Shield, Deflector	248	532 43 23-60	Shield Deck LH Assy.
29	532 13 14-91	Rod, Hinge	249	532 40 65-14	Cover Cable Clutch
32	532 15 35-32	Pulley, Mandrel	251	532 43 60-87	Kit Bungee (Includes Phillips head screw, self tapping screw, bungee latch, and bungee strap)
33	532 40 02-34	Nut, Toplock, Flanged			
34	872 11 06-12	Bolt Carr. Sh. 3/8-16 x 1-1/2 Gr. 5			
35	532 13 38-35	Fastener, Christmas Tree	253	532 42 73-50	Rivet
40	873 90 06-00	Nut, Lock Flg. 3/8-16 unc	254	587 05 59-02	Reinforcement Plate Front
41	584 95 39-01	Bolt Hex Wsh Hd 3/8-18 x 1.19	255	587 05 54-02	Reinforcement Plate Side
46	532 13 77-29	Screw	256	578 29 64-04	Screw Buttonhead 1/4-20
55	532 19 72-49	Arm, Idler	257	873 90 04-00	Nut Hex Flange 1/4-20 unc
56	532 19 90-92	Spacer, Retainer	--	532 19 28-70	Mandrel Assembly (Includes housing (key#14), shaft assembly (key#13), and bearing only (key#15) - pulley/nut/washer and blade bolt/washers not included)
57	817 00 06-16	Screw 3/8-16 x 1			
59	532 14 10-43	Guard, Tuv. Idler			
68	532 44 75-59	V-Belt			
69	872 14 05-05	Bolt			
80	532 42 30-62	Pal Nut	--	588 62 24-01	Replacement Mower, Complete
115	872 11 05-05	Bolt Carr. 5/6-18 x 5/8 Short			
116	532 12 48-42	Bolt Shoulder			
117	532 18 86-06	Wheel Gauge			
119	819 12 14-14	Washer 3/8 x 7/8 x 14 Ga.			
144	532 19 34-14	Keeper Belt			

NOTE: All component dimensions given in U.S. inches
1 inch = 25.4 mm

TRACTOR - - MODEL NO. TS 238 (96041036901), PRODUCT NO. 960 41 03-69
MOWER LIFT 45

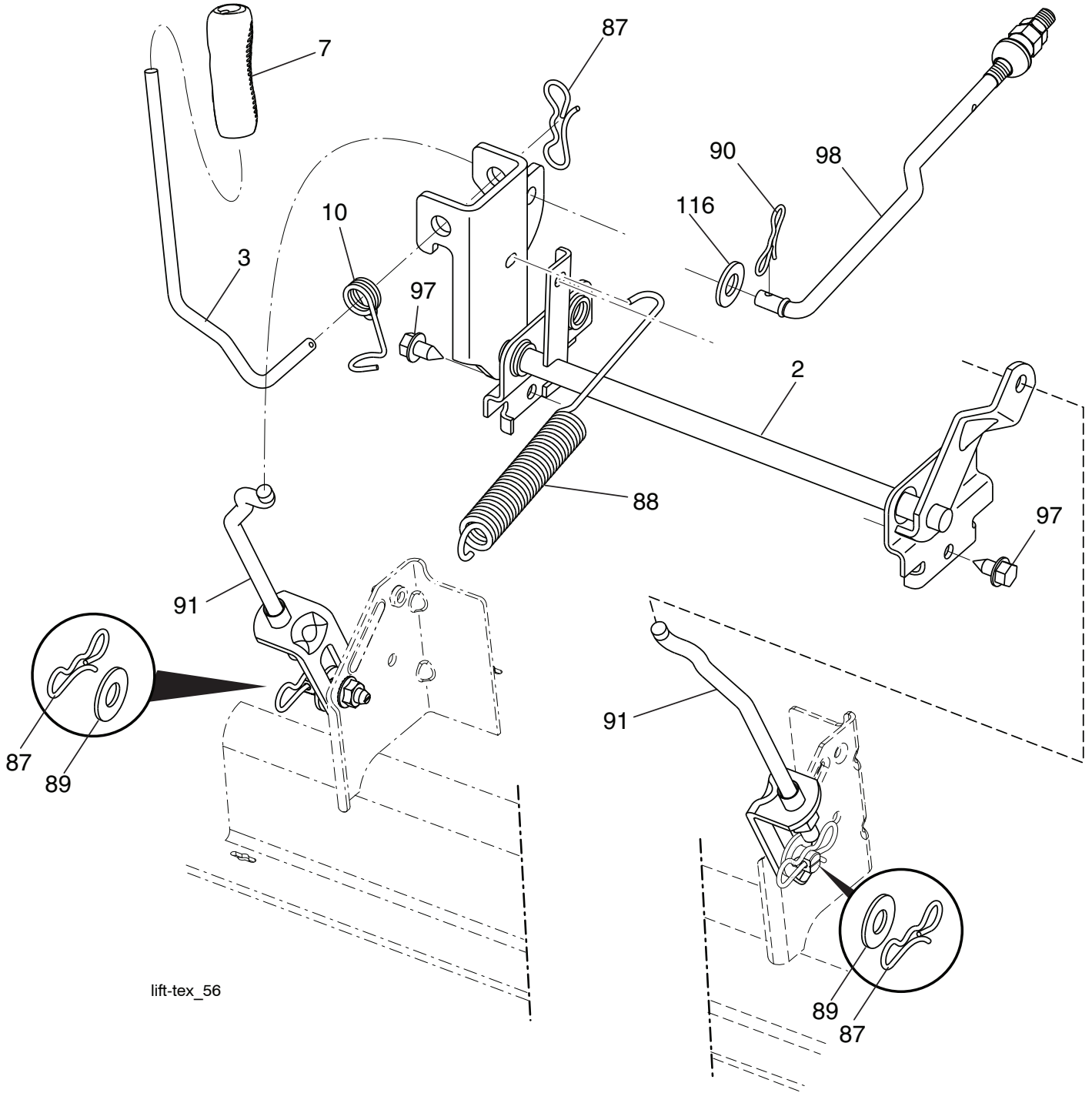

lift-tex_56

KEY NO.	PART NO.	DESCRIPTION
2	532 42 20-27	Shaft Asm., Lift
3	532 19 52-31	Lever Asm., Lift RH
7	580 96 23-01	Grip, Lever
10	532 19 63-14	Spring Torsion
87	532 19 42-09	Pin Cotter 7/16 Bow Tie Lock
88	532 41-07-10	Spring Lift Assist
89	819 19 19-12	Washer Clear Zinc
90	532 19 42-08	Pin Cotter 5/16 Bow Tie Lock

KEY NO.	PART NO.	DESCRIPTION
91	532 19 51-81	Link Lift Susp Mower Rear
97	817 00 06-12	Screw 3/8-16 x .75 Smgml Tap/R.Z
98	532 19 52-70	Link Lift Susp Front Mower
116	819 15 15-16	Washer 15/32 x 15/16 x 16 Ga.

NOTE: All component dimensions given in U.S. inches
 1 inch = 25.4 mm

**TRACTOR - - MODEL NO. TS 238 (96041036901), PRODUCT NO. 960 41 03-69
SEAT ASSEMBLY 42**

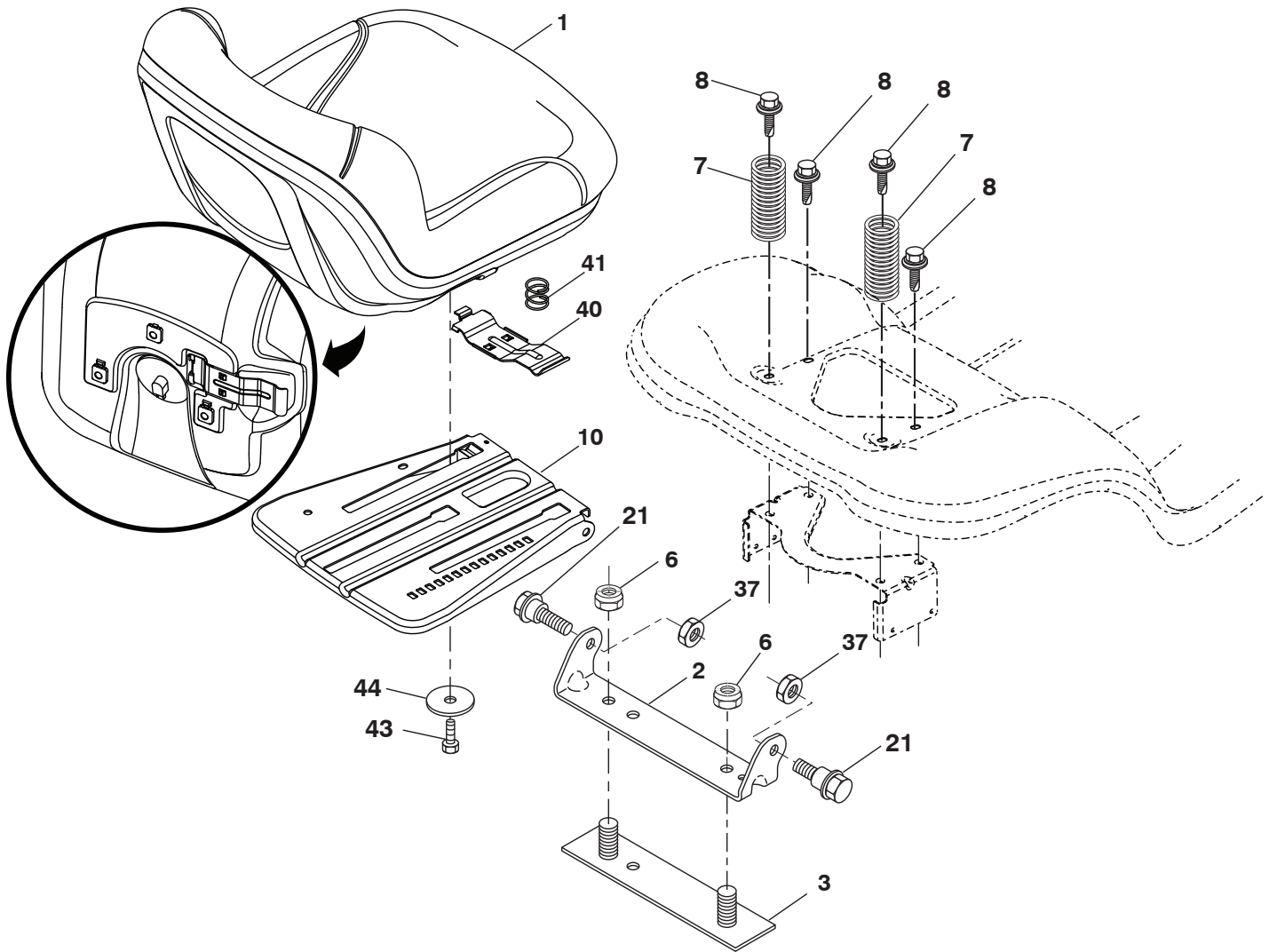

seat-tex_7A-vgt

KEY NO.	PART NO.	DESCRIPTION
1	532 43 98-19	Seat
2	532 18 01-66	Bracket Pivot Fender
3	532 14 06-75	Strap, Asm Fender
6	873 80 06-00	Nut, Lock w/Ins. 3/8-16 unc
7	587 61 33-01	Spring, Seat Cprsn
8	532 17 18-77	Bolt 5/16-18 unc x 3/4 w/Sems
10	532 19 69-77	Pan, Seat
21	532 17 18-52	Bolt, Shoulder 5/16-18

KEY NO.	PART NO.	DESCRIPTION
37	873 80 05-00	Nut, Lock 5/16-18 unc
40	532 19 76-61	Handle Slide
41	532 19 82-00	Spring Latch
43	874 76 06-12	Bolt 3/8-16 unc x 3/4
44	819 13 38-12	Washer 13/32 x 2-3/8 x 12

NOTE: All component dimensions given in U.S. inches
1 inch = 25.4 mm

