

ILLUSTRATED PARTS LIST

MFG. ID NO. 96041038700

CUSTOMER CATALOG NO. TS 348

PRODUCT NO. 960 41 03-87

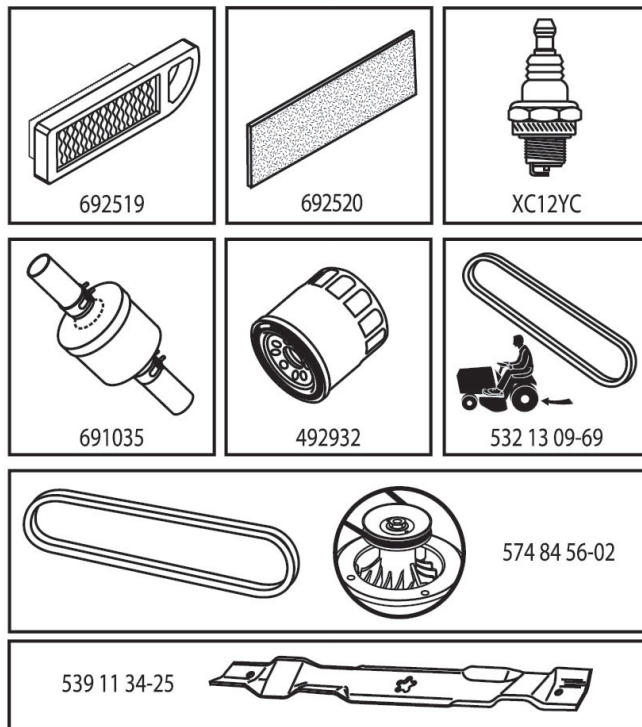

47

588739101

**TRACTOR - - MODEL NO. TS 348 (96041038700), PRODUCT NO. 960 41 03-87
DECALS 27**

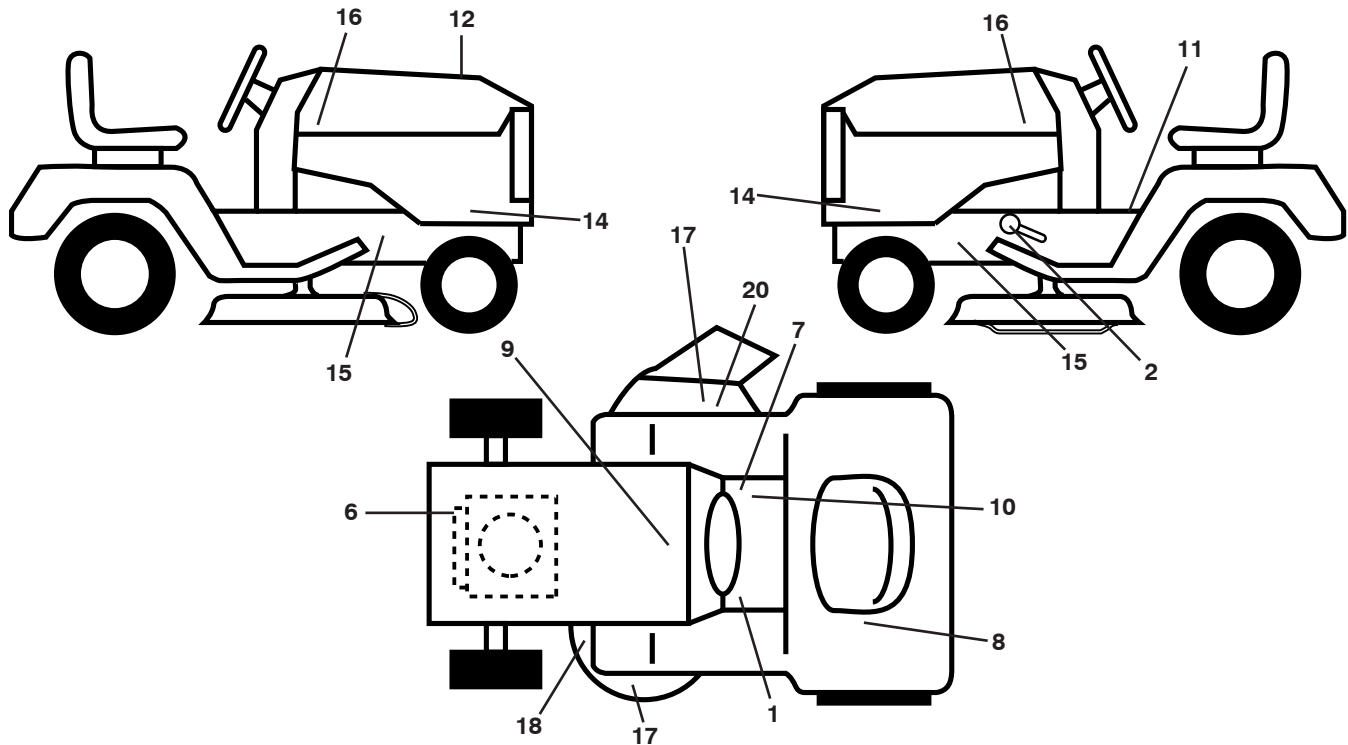

**KEYPART
NO. NO.**

KEYPART NO. NO.	DESCRIPTION
1 581 72 40-01	Decal, Brake/Clutch Sym
2 532 41 86-00	Decal, Fwd Pedal Dealer
6 581 57 97-01	Decal, Warning Eng. Syms.
7 581 57 80-01	Decal, Saddle Brake Parking
8 587 01 51-01	Decal, Warn. Reserve Fuel
9 532 14 50-05	Decal, Battery Dan./Poi.
10 586 80 03-01	Decal, Oper. Cruise Sym.
11 581 57 81-01	Decal, Warning Sym.
12 588 73 91-01	Decal, RPL
14 588 77 47-01	Decal, Panel Side
15 581 57 96-01	Decal, Chassis Hot Muffler
16 581 62 73-01	Decal, Badge Logo

**KEYPART
NO. NO.**

KEYPART NO. NO.	DESCRIPTION
17 581 72 43-01	Decal, No Step
18 581 58 00-02	Decal, Mower DFLCTR Warning CTFNGR
20 584 90 46-01	Decal, Deck Lift
-- 501 74 90-01	Decal, Drawbar Locking Differential
-- 581 72 48-01	Decal, Bypass
-- 532 43 98-82	Pad, Footrest, LH
-- 532 43 98-81	Pad, Footrest, RH
-- 581 72 46-01	Decal, Drawbar Load
-- 588 77 53-28	Manual, Operator's English

WHEELS AND TIRES

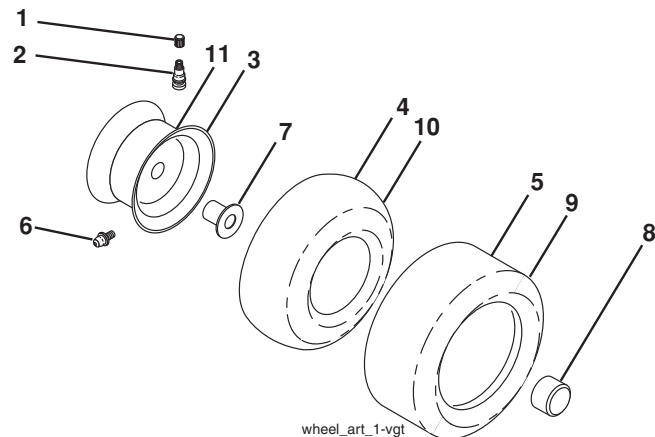

**KEYPART
NO. NO.**

KEYPART NO. NO.	DESCRIPTION
1 532 05 91-92	Cap, Valve, Tire
2 532 06 51-39	Stem, Valve
3 532 18 18-39	Rim Assembly, Front
4 532 05 99-04	Tube, Front (Service Item Only)
5 532 16 10-24	Tire, Front 16 x 6.5-8
6 532 12 49-57	Fitting, Grease (Front Wheel Only)
7 532 12 49-59	Bearing, Flange (Front Wheel Only)
8 532 17 50-39	Cap, Axle
9 532 17 04-56	Tire, Rear 20 x 10-8
10 532 12 49-26	Tube, Rear (Service Item Only)
11 532 13 83-37	Rim Assembly, Rear
-- 532 14 43-34	Sealant, Tire (10 oz. Tube)

NOTE: All component dimensions given in U.S. inches
1 inch = 25.4 mm

TRACTOR - - MODEL NO. TS 348 (96041038700), PRODUCT NO. 960 41 03-87

SCHEMATIC 38

SCH12

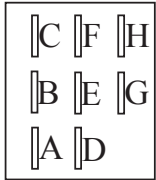
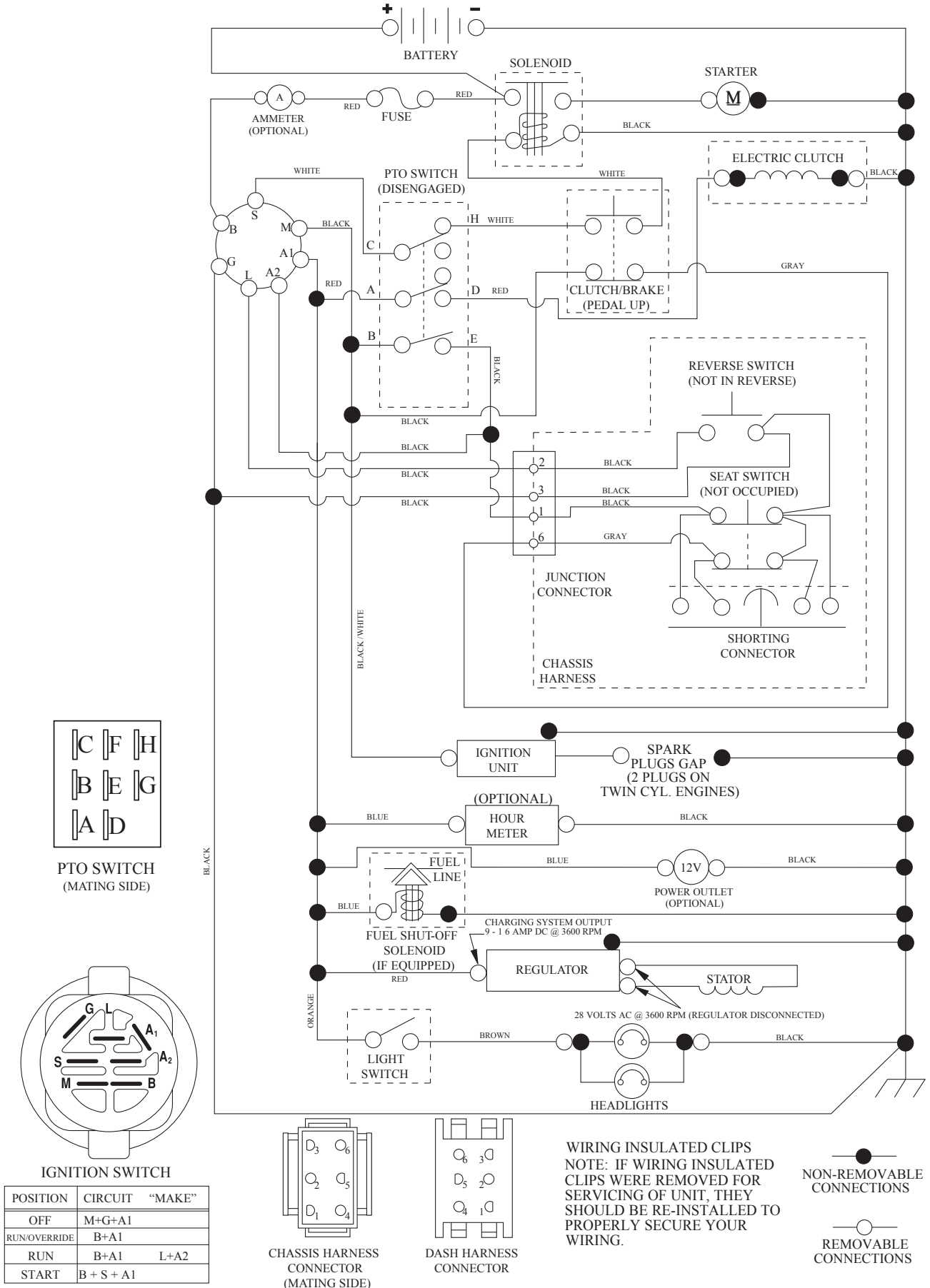

PTO SWITCH
(MATING SIDE)

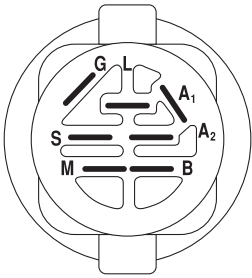

IGNITION SWITCH

POSITION	CIRCUIT	"MAKE"
OFF	M+G+A1	
RUN/OVERRIDE	B+A1	
RUN	B+A1	L+A2
START	B + S + A1	

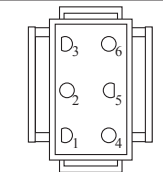

CHASSIS HARNESS
CONNECTOR
(MATING SIDE)

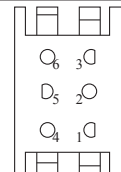

DASH HARNESS
CONNECTOR

WIRING INSULATED CLIPS
NOTE: IF WIRING INSULATED
CLIPS WERE REMOVED FOR
SERVICING OF UNIT, THEY
SHOULD BE RE-INSTALLED TO
PROPERLY SECURE YOUR
WIRING.

NON-REMOVABLE
CONNECTIONS

REMOVABLE
CONNECTIONS

TRACTOR - - MODEL NO. TS 348 (96041038700), PRODUCT NO. 960 41 03-87
ELECTRICAL 32

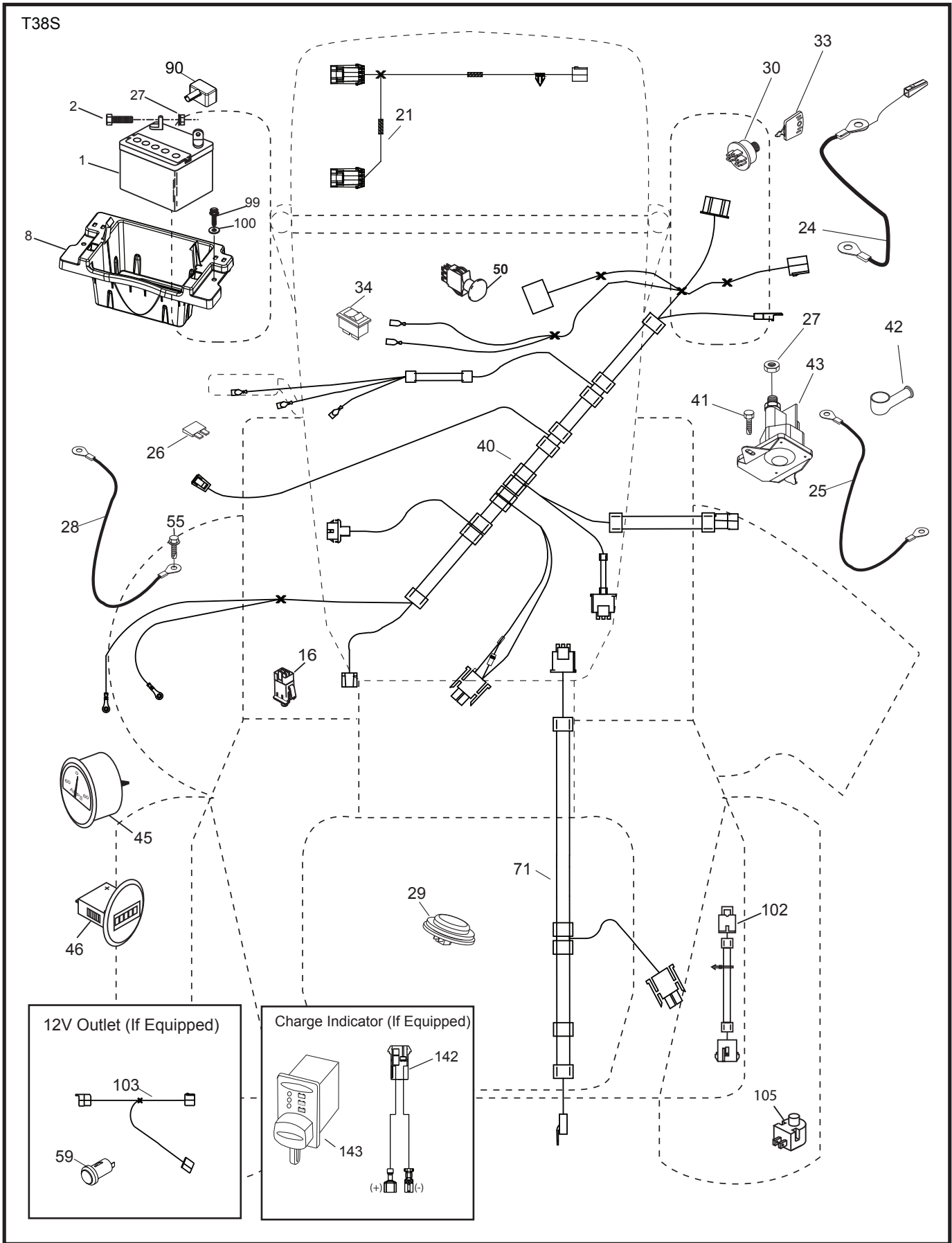

**TRACTOR - - MODEL NO. TS 348 (96041038700), PRODUCT NO. 960 41 03-87
ELECTRICAL 32**

KEY PART NO.	NO.	DESCRIPTION
1	532 16 34-65	Battery
2	874 76 04-12	Bolt Hex Hd. 1/4-20 unc x 3/4
8	587 20 51-01	Battery Box
16	532 17 61-38	Switch Interlock
21	585 43 64-01	Harness Light
24	585 55 56-01	Cable Battery
25	585 55 55-01	Cable Starter
26	532 17 51-58	Fuse
27	873 51 04 00	Nut Keps Hex 1/4-20 unc
28	532 41 65-88	Cable Ground
29	532 40 15-45	Switch Seat
30	532 19 33-50	Switch Ign.
33	532 41 19-35	Key/Chain
34	532 11 07-12	Switch Light
40	501 13 31-01	Harness Ign. Dash
41	817 72 04-08	Screw 1/4-20 x 1/2
42	532 13 15-63	Cover Terminal
43	532 19 25-07	Solenoid
45	587 55 39-03	Ammeter Guage Round
46	587 55 40-03	Hourmeter Gauge
50	582 10 76-01	Switch PTO
55	817 06 05-12	Screw 5/16-18 x 3/4
71	532 19 42-76	Harness Ign. Chassis
90	532 43 53-95	Cover Terminal Battery
99	817 67 04-12	Screw Hex Wsh. Thdrol. 1/4-20 x 3/4
100	819 09 14-16	Washer 9/32 x 7/8 x 16 Ga.
102	532 40 44-54	Harness Pigtail Tex ROS Tufftorq
105	532 40 75-68	Switch Reverse

NOTE: All component dimensions given in U.S. inches
1 inch = 25.4 mm

TRACTOR - - MODEL NO. TS 348 (96041038700), PRODUCT NO. 960 41 03-87
CHASSIS AND ENCLOSURES **39**

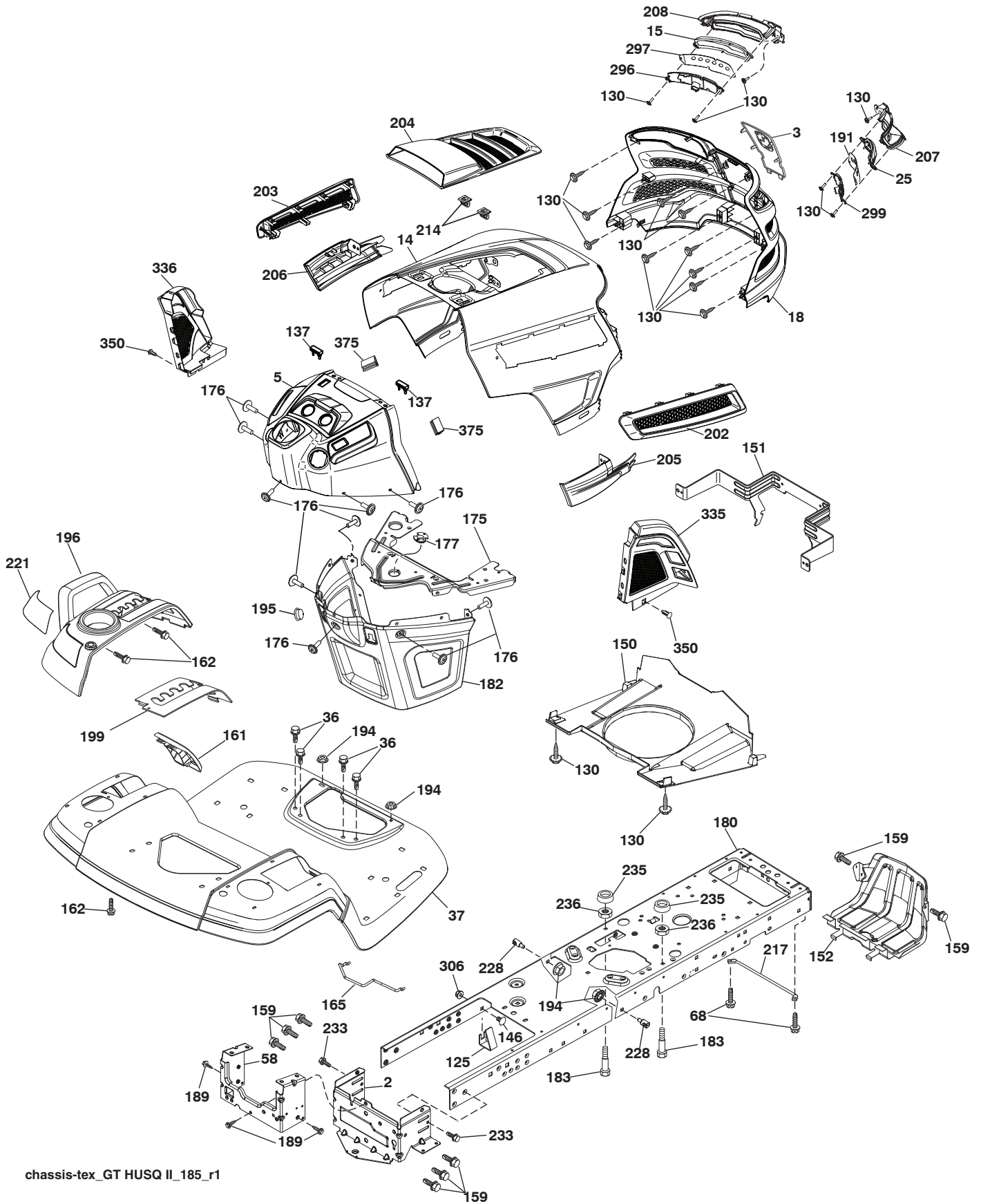

**TRACTOR - - MODEL NO. TS 348 (96041038700), PRODUCT NO. 960 41 03-87
CHASSIS AND ENCLOSURES 39**

KEY NO.	PART NO.	DESCRIPTION
2	532 41 22-82	Drawbar Lower
3	532 44 44-81	Applique
5	582 09 11-01	Dash
14	532 44 11-77	Hood
15	585 42 03-01	Lens LH
18	587 52 34-01	Grille
25	585 42 02-01	Lens RH
36	817 06 05-12	Screw 5/16-18 x 3/4
37	532 44 12-08	Fender
58	532 41 22-81	Drawbar Upper
68	817 49 05-08	Screw 5/16-18 x 1/2
125	581 68 48-01	Clip Fuel Line
130	532 41 63-58	Screw #10 x 0.750 BOS Thread
137	532 40 75-90	Bumper Dash
146	581 85 79-01	Bolt
150	532 43 97-31	Air Duct
151	532 43 66-70	Bracket Pivot
152	532 43 98-70	Shield Browning
159	817 00 06-12	Screw Hexwsh THDR 3/8 - 16x3/4
161	532 43 99-29	Window Fuel
162	532 14 24-32	Screw
165	532 19 43-30	Support Tank Rear
175	532 19 63-04	Crossmember
176	532 40 07-76	Screw 10-24 x 5/8
177	532 19 52-28	Bushing Steering
180	532 44 55-59	Chassis
182	532 40 68-59	Dash Lower
183	874 52 05-20	Bolt 5/16-18 x 1-1/4 Full Thread
189	817 00 05-12	Screw 5/16-18 x 3/4
191	586 18 28-01	Insert RH
194	873 90 05-00	Nut Lock Hex Flange 5/16-18

KEY NO.	PART NO.	DESCRIPTION
195	532 40 41-37	Plug Hole Dash Lower
196	532 43 97-16	Console Asm. Deck Lift
199	532 19 82-59	Plate Deck Lift
202	532 43 97-28	Vent Side Hood RH
203	532 43 97-27	Vent Side Hood LH
204	532 44 44-84	Vent Top Hood
205	532 43 97-30	Trim Hood Side RH
206	532 43 97-29	Trim Hood Side LH
207	585 42 00-02	Bezel RH
208	585 42 01-02	Bezel LH
214	532 19 91-45	Clip Retainer Tinner
217	532 40 91-67	Rod Pivot
221	532 19 89-09	Reflector LH
228	532 19 51-61	Stud Fastner
233	532 19 65-39	Bolt Shoulder
235	532 40 61-29	Spacer Fender
236	873 93 05-00	Nut Lock 5/16-18 unc
296	585 42 05-01	LED Light LH
297	586 18 29-01	Insert LH
299	585 42 04-01	LED Light RH
306	873 90 06-00	Nut Lock
335	532 44 82-04	Cover Dash RH
336	532 44 53-09	Cover Dash LH
350	532 44 51-43	Clip X-mas Tree
375	586 90 82-01	Dash Clip-On Bumper
--	532 43 18-82	Kit Guard Brush

NOTE: All component dimensions given in U.S. inches
1 inch = 25.4 mm

TRACTOR - - MODEL NO. TS 348 (96041038700), PRODUCT NO. 960 41 03-87
DRIVE **40**

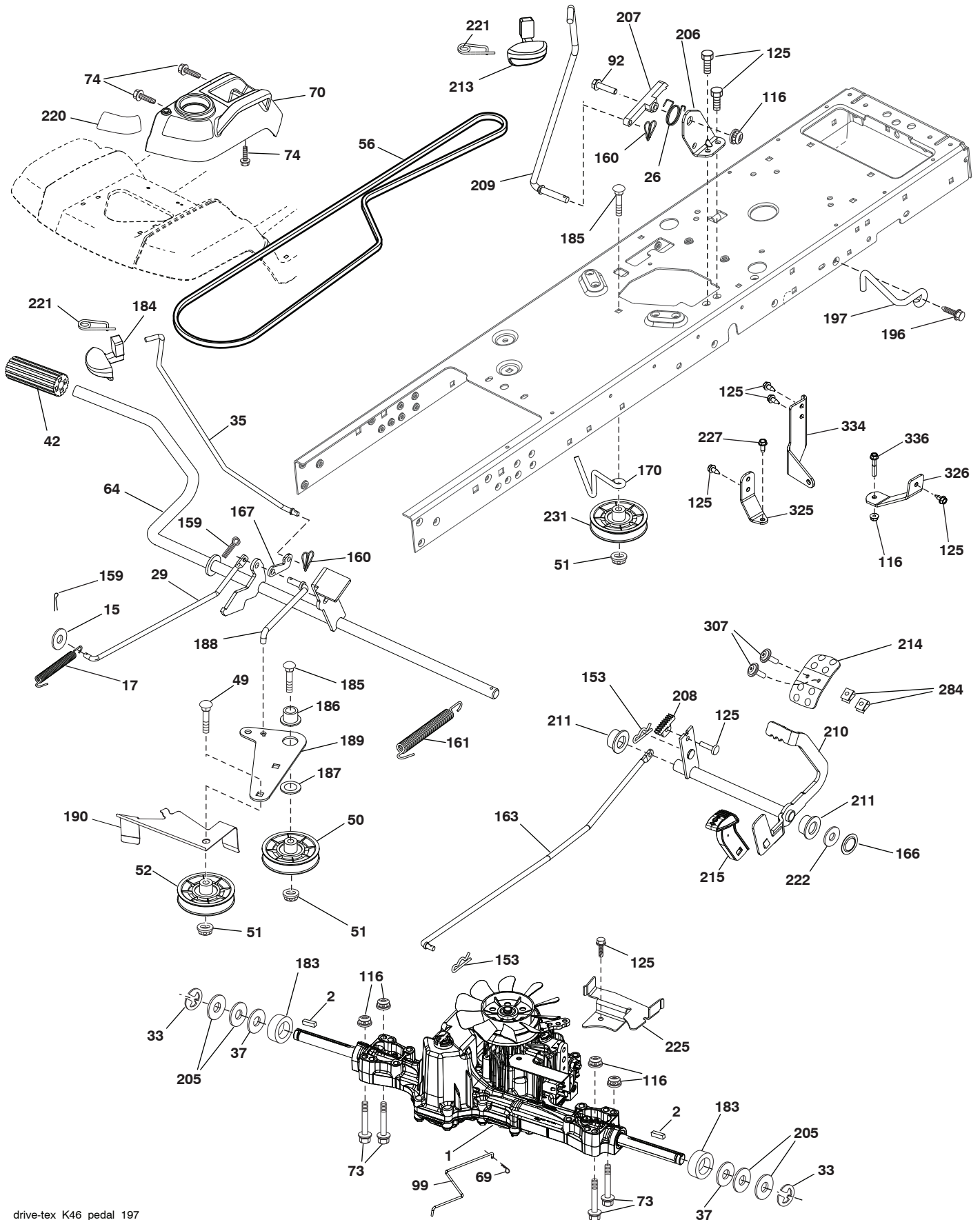

drive-tex_K46_pedal_197

**TRACTOR - - MODEL NO. TS 348 (96041038700), PRODUCT NO. 960 41 03-87
DRIVE 40**

KEY NO.	PART NO.	DESCRIPTION	KEY NO.	PART NO.	DESCRIPTION
1	-----	Transaxle, TUFFTORQ K46 CR (501051401) (Order parts from transaxle manufacturer.)	185	872 11 06-22	Bolt Rdhd Sqnk 3/8-16 x 2-1/2
2	532 12 35-83	Key	186	532 19 43-21	Spacer Retainer
15	819 13 13-16	Washer 13/32 x 13/16 x 16 Ga.	187	819 13 32-10	Washer
17	532 41 36-78	Spring, Brake	188	582 21 70-01	Link Clutch Ground Drive, Long
26	532 19 96-79	Spring Return Cruise	189	532 19 43-17	Bellcrank Ground Drive
29	532 40 38-06	Rod, Brake	190	532 19 43-18	Keeper Bellcrank Ground Drive
33	812 00 00-01	Ring E	196	817 00 06-16	Screw 3/8-16 x 1
35	583 86 45-01	Rod, Brake, Park	197	585 65 86-01	Link Clutch Anti-Rotation
37	532 18 89-67	Washer Hardened	205	532 12 17-48	Washer
42	532 12 48-72	Cover, Foot Pedal	206	532 44 85-96	Bracket Mount Latch Cruise
49	872 11 06-14	Bolt	207	587 03 14-01	Latch Control Cruise
50	532 19 43-27	Pulley Idler Flat	208	532 19 78-69	Gear Sector Control Cruise
51	873 90 06-00	Lock Nut 3/8-16	209	532 19 95-92	Rod Control Cruise
52	532 19 43-26	Idler V-Groove	210	532 19 78-60	Rocker Asm. Pedal Control
56	532 13 09-69	V-Belt, Drive	211	532 12 01-83	Bearing Nylon
64	532 19 78-65	Shaft Asm. Pedal Brake Control	213	532 40 31-19	Knob Control Cruise
69	532 42 33-03	Hairpin Soft Zink .059 x 1.125	214	532 41 68-63	Pedal Forward
70	532 43 96-61	Console Shift	215	586 60 65-02	Pedal Reverse
73	874 49 05-40	Bolt Hex Flghd 5/16-18 Gr. 5	220	532 19 89-08	Reflector RH
74	532 14 24-32	Screw Hex Wsh. Hi-Lo 1/4 x 1/2 unc	221	532 40 31-87	Retainer Spring Clip Handle
92	874 76 05-20	Bolt Fin Hex 5/16-18 unc x 1.25	222	879 21 20-10	Washer 21/32 x 1-1/4 x 10 Ga.
99	582 40 45-01	Rod Spring Bypass	225	532 40 33-19	Keeper Belt Trans.
116	873 90 05-00	Nut Lock Hex Flange 5/16-18	227	817 49 05-12	Screw Thdrol 5/16-18 x 3/4
125	817 00 05-12	Screw 5/16-18 x 3/4	231	532 40 72-87	Idler V-Groove
153	532 12 47-88	Retainer Spring	284	532 41 76-93	Nut U-CHNL 1/4-20
159	876 02 04-12	Pin Cotter 1/8 x 3/4	307	874 18 04-12	Screw MACH CR 1/4-20 x 3/4
160	532 16 94-84	Retainer Clip	325	586 43 12-02	Torque Strap K46 LT LH
161	532 10 57-09	Spring, Return, Clutch	326	586 00 11-02	Bracket TRQ STP 46 20" Tire RH
163	532 44 82-75	Rod Pedal Control	334	585 88 22-02	Sway Bar Bracket
166	532 42 91-64	Nut Push	336	587 25 96-01	Bolt 5/16-18 x 1-3/4 Flanged
167	532 40 52-57	Latch Brake Parking			
170	532 41 34-30	Keeper Belt Centerspan			
183	532 13 70-57	Spacer Split			
184	587 65 37-01	Handle Parking Brake			

NOTE: All component dimensions given in U.S. inches
1 inch = 25.4 mm

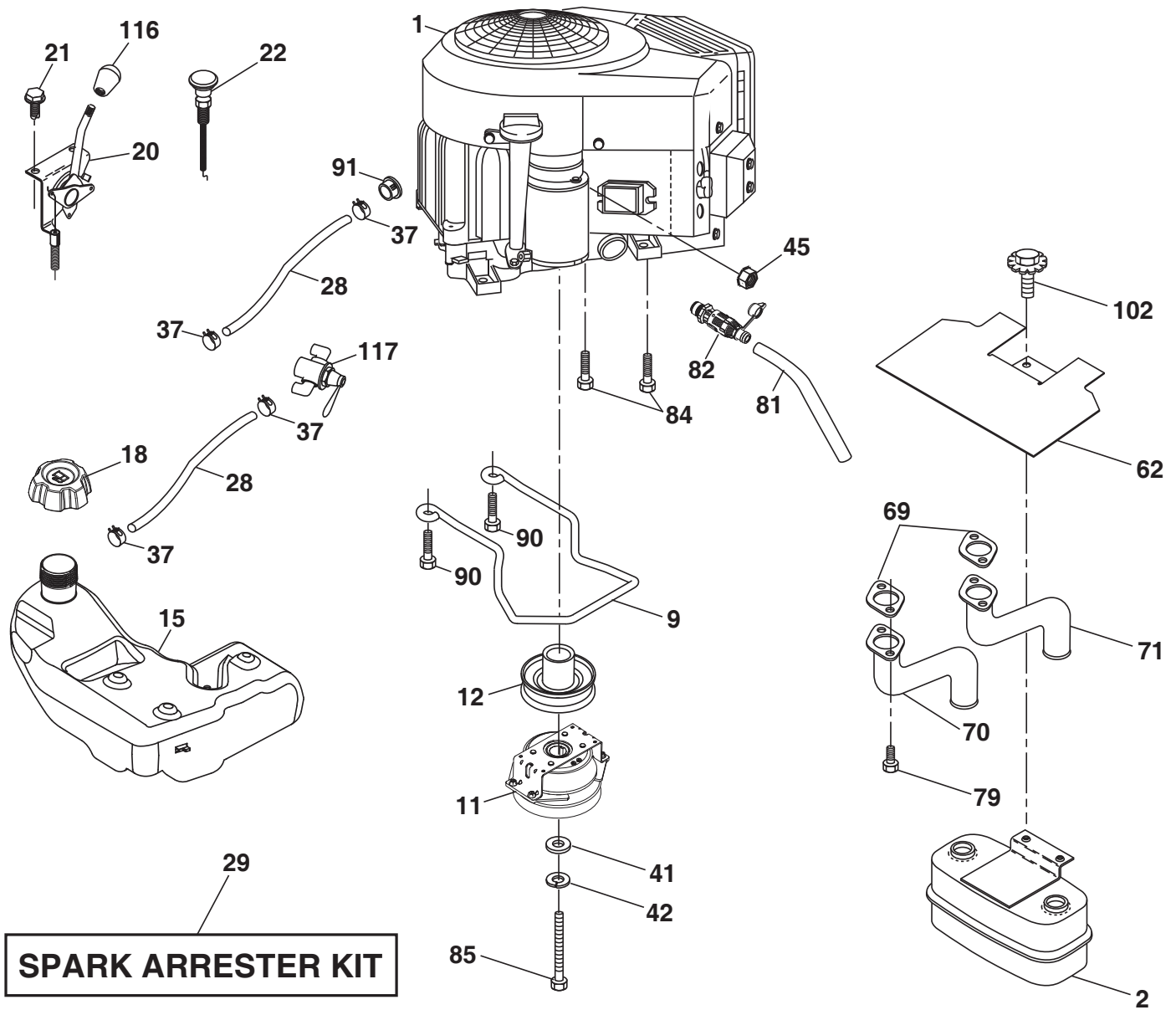

engine-tex_bs-2cyl_161

**TRACTOR - - MODEL NO. TS 348 (96041038700), PRODUCT NO. 960 41 03-87
ENGINE 24**

KEY NO.	PART NO.	DESCRIPTION
1	-----	Engine Briggs Model No. 385777-0007-G1 (588627901) (Order parts from engine manufacturer.)
2	532 44 59-62	Muffler
9	501 83 26-02	Keeper Belt Engine
11	587 24 16-01	Clutch Electric
12	532 40 50-97	Pulley Engine
15	532 42 28-04	Tank Fuel
18	584 24 87-02	Cap
20	532 42 43-41	Control Throttle
21	532 41 63-58	Screw #10 x .750 BOS Thread
22	532 18 95-41	Control Choke
28	587 04 46-61	Fuel Line
29	532 13 71-80	Spark Arrester Kit
37	532 12 34-87	Clamp Hose
41	532 12 61-97	Washer 1-1/2 OD x 15/32 ID x .250
42	810 04 07-00	Washer Lock 7/16
45	873 51 04-00	Nut Keps Hex 1/4-20 unc
62	532 43 40-17	Heat Shield
69	532 19 24-42	Gasket
70	532 19 15-48	Tube Exhaust LH
71	532 19 15-49	Tube Exhaust RH
79	532 19 24-43	Screw Socket HP 5/16-18 x 1
81	532 14 84-56	Tube Drain Oil
82	532 42 82-87	Valve, Oil Drain
84	817 06 06-20	Screw 3/8-16 x 1-1/4
85	501 60 66-01	Bolt 7/16-20 x 3.75 Gr.
90	817 00 06-16	Screw 3/8-16 x 1
91	532 18 74-95	Bushing 1.375 OD
102	817 00 05-12	Screw 5/16-18 x 3/4
116	539 13 26-24	Knob-Shift
117	532 42 08-28	Valve Fuel Reserve

NOTE: All component dimensions given in U.S. inches
1 inch = 25.4 mm

Engine Power Rating Information

The gross power rating for individual gas engine models is labeled in accordance with SAE (Society of Automotive Engineers) code J1940 (Small Engine Power & Torque Rating Procedure), and rating performance has been obtained and corrected in accordance with SAE J1995 (Revision 2002-05). Torque values are derived at 3060 RPM; horsepower values are derived at 3600 RPM. Actual gross engine power will be lower and is affected by, among other things, ambient operating conditions and engine-to-engine variability. Given both the wide array of products on which engines are placed and the variety of environmental issues applicable to operating the equipment, the gas engine will not develop the rated gross power when used in a given piece of power equipment (actual "on-site" or net power). This difference is due to a variety of factors including, but not limited to, accessories (air cleaner, exhaust, charging, cooling, carburetor, fuel pump, etc.), application limitations, ambient operating conditions (temperature, humidity, altitude), and engine-to-engine variability. Due to manufacturing and capacity limitations, Briggs & Stratton may substitute an engine of higher rated power for this Series engine.

TRACTOR - - MODEL NO. TS 348 (96041038700), PRODUCT NO. 960 41 03-87
STEERING ASSEMBLY 41

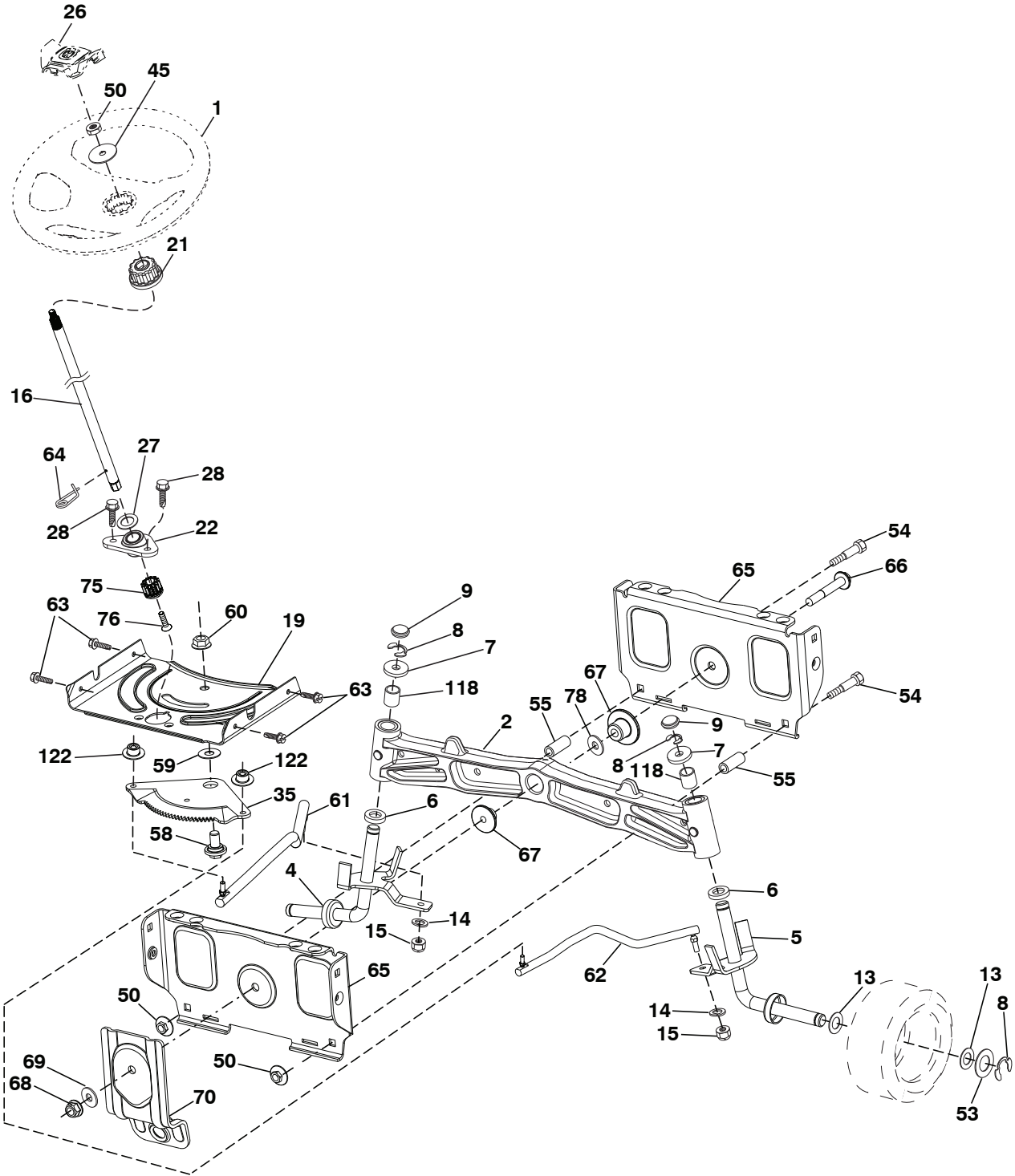

steering-tex_HUSQSR_68

**TRACTOR - - MODEL NO. TS 348 (96041038700), PRODUCT NO. 960 41 03-87
STEERING ASSEMBLY 41**

KEY NO.	PART NO.	DESCRIPTION
1	532 43 97-40	Wheel, Steering
2	532 41 35-91	Axle Asm., Front
4	532 40 30-89	Spindle Asm., LH
5	532 40 30-90	Spindle Asm., RH
6	532 12 49-31	Bearing, Race Thrust Harden
7	532 12 17-48	Washer 25/32 x 1-5/8 x 16 Ga.
8	812 00 00-29	Ring, Clip #T5304-75
9	532 12 12-32	Cap, Spindle
13	532 12 17-49	Washer 25/32 x 1-1/4 x 16 Ga.
14	810 04 06-00	Washer, Lock Hvy Hlcl Spr 3/8
15	873 54 06-00	Nut, Crown Lock 3/8-24 unf
16	587 01 60-02	Steering Shaft
19	532 19 47-29	Plate Steering
21	586 84 02-01	Adapter Wheel Steering
22	585 02 98-02	Bearing
26	532 43 97-43	Insert, Wheel Steering
27	819 21 16-16	Washer
28	817 00 06-12	Screw 3/8-16 x 3/4
35	532 19 47-32	Gear, Sector Plate
45	587 01 64-01	Washer 3/8 ID 2-3/8 OD 12 Ga. PLTD
50	873 90 06-00	Nut Lock Flg 3/8-16 unc
53	532 18 89-67	Washer Hardened .793 x 1.637 x .060
54	874 76 06-36	Bolt Hex 3/8-16 unc x 2-1/4
55	532 41 47-36	Spacer Brace Axle
58	532 19 47-47	Bolt Shoulder Sector Pivot CFM
59	532 19 47-48	Washer Thrust Sector Steering
60	873 97 10-00	Nut Flange Lock 5/8-11
61	588 79 44-01	Draglink, LH
62	588 79 45-01	Draglink, RH
63	817 00 05-12	Screw 5/16-18 x 3/4
64	532 19 98-49	Retainer Clip Spring Steering
65	532 19 47-34	Brace Axle Front
66	871 02 07-48	Bolt Hex Fghd 7/16-14 x 3 Serr
67	532 19 47-37	Bushing PM Front Axle
68	873 90 07-00	Nut Lock Flange 7/16-14 Gr. 5
69	532 19 91-62	Washer 1.5 x .505 x .118
70	585 33 88-01	Bracket Deck Susp. Front
75	580 68 37-01	Pinion
76	580 68 36-01	Screw Head Sock
78	532 05 70-79	Washer Thrust
118	532 40 60-13	Bushing
122	532 44 49-62	Cap Gear

NOTE: All component dimensions given in U.S. inches
1 inch = 25.4 mm.

TRACTOR - - MODEL NO. TS 348 (96041038700), PRODUCT NO. 960 41 03-87
MOWER DECK 44

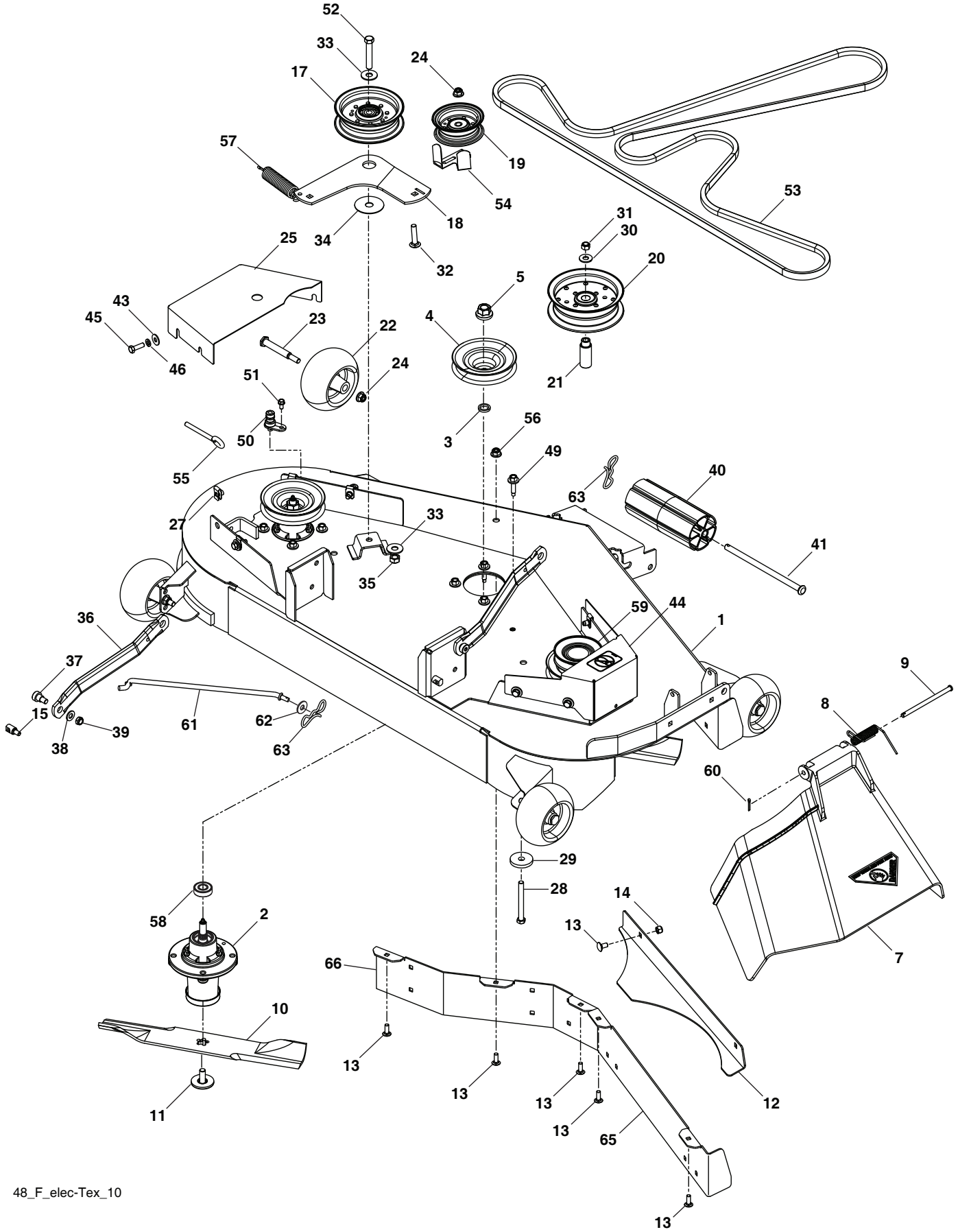

**TRACTOR - - MODEL NO. TS 348 (96041038700), PRODUCT NO. 960 41 03-87
MOWER DECK 44**

KEY NO.	PART NO.	DESCRIPTION	KEY NO.	PART NO.	DESCRIPTION
1	587 64 10-05	Deck	39	539 20 02-82	Nut, 3/8-16 Hex Jam Nyloc
2	539 11 21-70	Housing Assembly	40	532 17 60-66	Roller, Nose
3	532 18 76-90	Washer-Spacer	41	532 17 91-27	Rod, Roller, Nose, Narrow
4	532 17 43-75	Pulley, Mandrel	43	819 12 14-14	Washer, 3/8 x 7/8 x 14 Ga
5	532 40 02-34	Nut, Flange Lock Top	44	575 96 72-05	Shield, Belt RH
7	539 11 07-32	Discharge Chute	45	874 78 05-16	Bolt Fin Hx 5/16-18 x 1
8	539 11 07-35	Spring - Torsion	46	810 03 05-00	Wash 5/16 Slw
9	539 11 07-36	Pin, Clevis 5/16 x 5.19	49	584 95 39-01	Bolt Hex
10	539 11 34-25	Blade, 16-1/4"	50	532 41 55-98	Washout Port
11	532 19 30-03	Bolt, Washer Asm 7/16-20	51	817 49 04-08	Bolt, 1/4-20 x 1/2
12	539 11 34-26	Confinement Plate	52	874 78 07-40	Hcs 7/16-14 x 2-1/2 Gr 5
13	872 11 05-05	Bolt Carr. 5/16-18 x 5/8 Short	53	574 84 56-02	Belt, Deck
14	873 80 05-00	Nut 5/16-18 Hex Nyloc	54	532 14 10-43	Guard, Belt
15	532 19 51-61	Stud, Fasten w/ Anti- Rotate	55	539 11 55-74	Eyebolt 5/16 x 3-1/2
17	532 19 61-04	Pulley, Idler Spec. Hub	56	539 99 05-85	Nut 5/16-18 Hex Whizlock
18	574 82 71-02	Arm, Idler, Blk	57	539 10 68-50	Spring
19	532 17 79-68	Pulley, Idler	58	532 11 04-85	Ball Bearing
20	539 13 27-28	Pulley, Idler	59	575 35 29-01	Pulley
21	575 22 45-01	Idler Bushing	60	532 16 94-84	Clip Retainer
22	532 13 39-57	Wheel, Gauge	61	532 40 48-51	Rod Anti Sway
23	532 19 34-06	Bolt, Shoulder 3/8 16 x 3-5/8	62	819 13 13-12	Washer 13/32 x 13/16 x 12 Ga.
24	521 99 65-01	Nut 3/8-16 Hex Flg Nyloc	63	532 19 42-08	Pin Cotter 5/16 Bow Tie Lock
25	575 22 47-06	Shield, Belt LH	65	580 94 16-04	Baffle Front RH
27	539 10 47-63	Retainer 5/16c U Type	66	584 65 15-04	Baffle Front LH
28	539 10 82-71	Hcs 3/8-16 x 3-1/2 Gr 5	--	588 82 65-01	Mower Deck Complete
29	539 10 65-04	Heavy Washer			
30	819 14 16-14	Washer, 3/8 Flat Std			
31	539 97 69-79	Nut 3/8-16 Hex Nyloc			
32	539 99 09-23	Rhsnb 3/8-16 x 1-3/4 Gr 5			
33	539 10 48-64	Washer, 7/16 Flat			
34	532 17 85-15	Washer, Flat Hardened			
35	873 90 07-00	Nut, 7/16-14 Hex			
36	532 19 51-85	Arm, Susp., Rear			
37	539 11 36-21	Sb 3/8-16 x 3/8 Skt Hd			
38	819 13 13-16	Washer, 13/32 x 13/16 x 16 Ga			

NOTE: All component dimensions given in U.S. inches
1 inch = 25.4 mm

TRACTOR - - MODEL NO. TS 348 (96041038700), PRODUCT NO. 960 41 03-87
MOWER LIFT 45

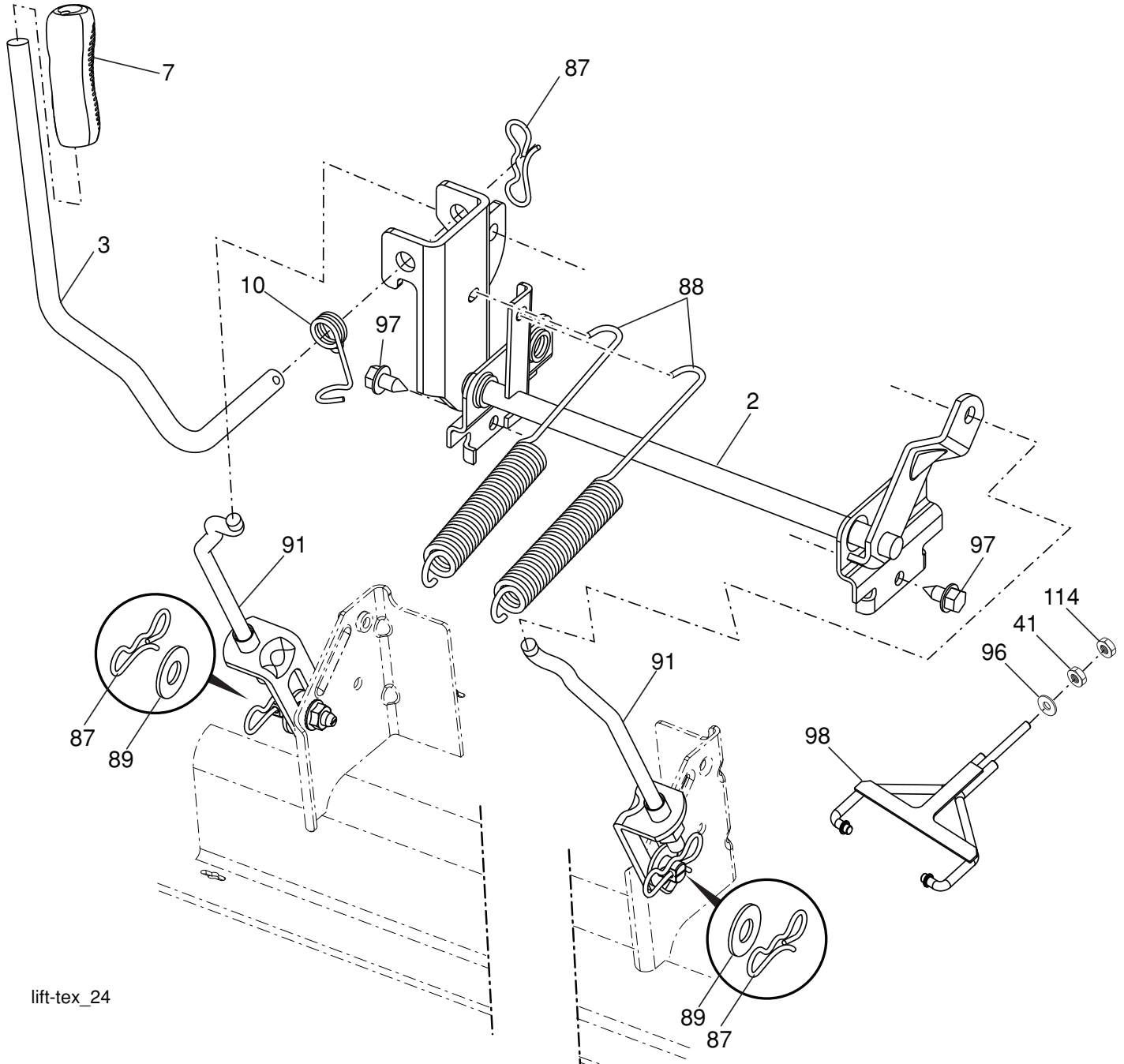

lift-tex_24

KEY NO.	PART NO.	DESCRIPTION
2	532 42 20-27	Shaft Asm., Lift
3	532 19 52-30	Lever Asm., Lift RH
7	580 96 23-01	Grip, Lever
10	532 19 63-14	Spring Torsion
41	532 17 59-94	Nut, Lift Link
87	532 19 42-09	Pin Cotter 7/16 Bow Tie Lock
88	532 41 07-10	Spring Lift Assist
89	819 19 19-12	Washer Clear Zinc

KEY NO.	PART NO.	DESCRIPTION
91	532 40 34-07	Link Lift Susp Mower Rear
96	532 19 52-63	Bushing, Spherical
97	817 00 06-12	Screw 3/8-16 x .75
98	574 82 25-01	Link Lift Susp. Front Mower
114	873 36 07-00	Nut Jam 7/16-20

NOTE: All component dimensions given in U.S. inches
 1 inch = 25.4 mm

**TRACTOR - - MODEL NO. TS 348 (96041038700), PRODUCT NO. 960 41 03-87
SEAT ASSEMBLY 42**

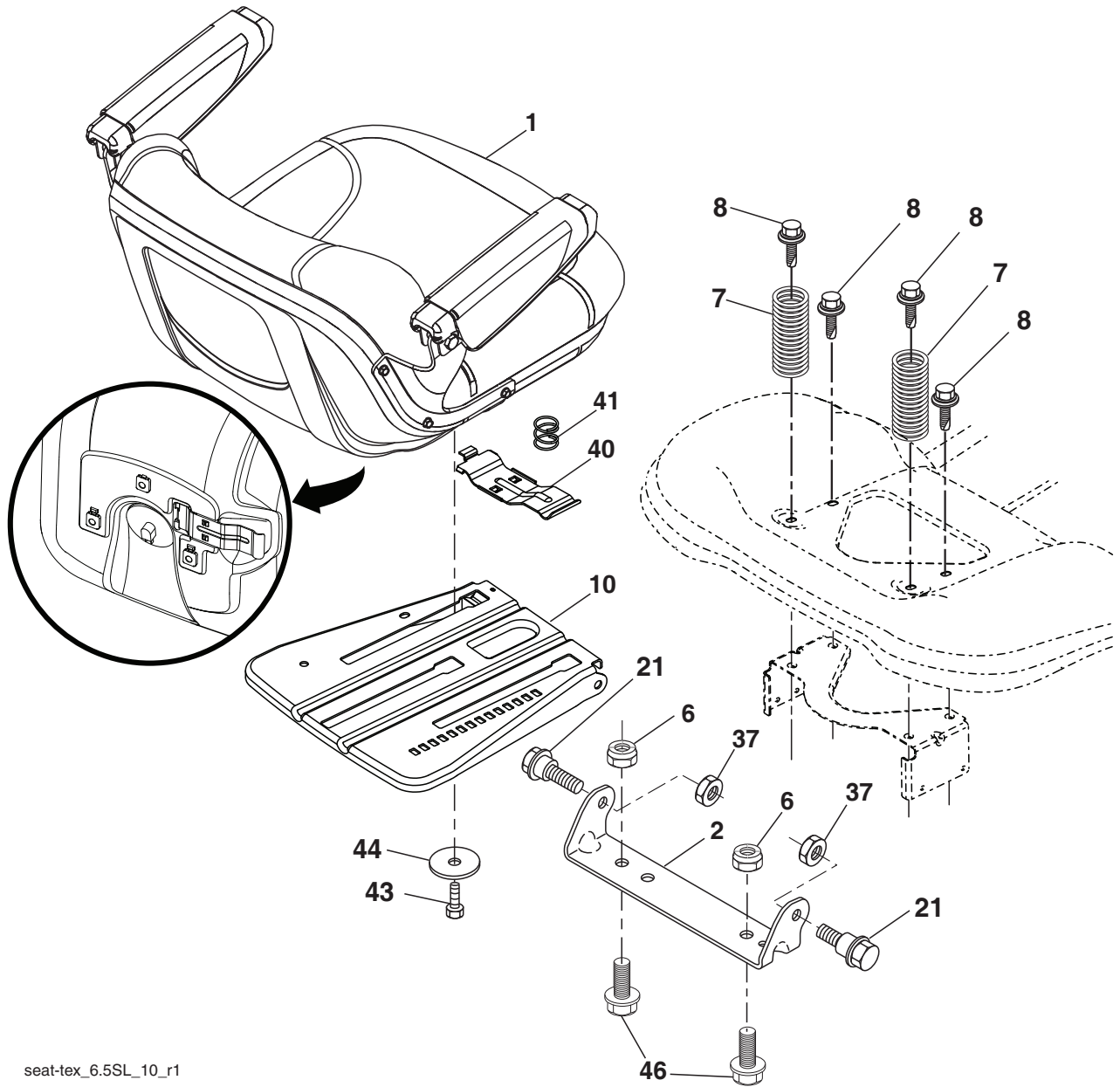

seat-tex_6.5SL_10_r1

KEY NO.	PART NO.	DESCRIPTION
1	532 44 32-63	Seat
2	532 18 01-66	Bracket Pivot Fender
6	873 80 06-00	Nut, Lock W/Ins. 3/8-16 unc
7	587 61 33-01	Spring, Seat Cprsn
8	532 17 18-77	Bolt 5/16-18 unc x 3/4 w/Sems
10	532 19 69-77	Pan, Seat
21	587 90 78-01	Bolt, Shoulder 5/16-18 x 5/8
37	873 80 05-00	Nut, Lock 5/16-18 unc

KEY NO.	PART NO.	DESCRIPTION
40	532 43 98-71	Handle Slide Seat
41	532 19 82-00	Spring Latch Seat
43	874 76 06-12	Bolt Fin Hex 3/8-16 unc x 3/4
44	819 13 38-12	Washer 13/32 x 2-3/8 x 12 Ga.
46	588 09 04-01	Bolt 3/8-16x1, 1.25 OD Wshr Sems

NOTE: All component dimensions given in U.S. inches
1 inch = 25.4 mm

